

TRZ 03



TRZ 03-K

Operating Instructions

Turbine Meters TRZ 03 and TRZ 03-K

Status: April, 24th 2026
Version: 12

Manufacturer Our customer service is available for technical queries

| | |
|----------------------------|--|
| Address | RMG Messtechnik GmbH Otto-Hahn-Straße 5 D-35510 Butzbach |
| Telefon switchboard | +49 6033 897 – 0 |
| Telefon service | +49 6033 897 – 897 |
| Telefon spare parts | +49 6033 897 – 897 |
| Fax | +49 6033 897 – 130 |
| E-mail | service@rmg.com |

Original Document The TRZ03_MAN_V12_04.2026_00.10.131.02-EN from April, 24th 2026 for the turbine gas meter TRZ03 is the document translated first from the German original version. Anyhow, this document may serve as reference for translations into other languages. Please use in case of any uncertainties the German version as main reference.

Note The latest version of this manual (and other devices) can be downloaded at your convenience from our Internet homepage

www.rmg.com.

| | |
|--------------------------------------|----------------|
| Date created | October 2008 |
| ... | |
| 8th revision date | April 2019 |
| 9th revision date | October 2019 |
| 10th revision date | December 2024 |
| 11th revision date | September 2025 |

| | | |
|--------------------------------------|-------------------------|---|
| Document version and language | Dokument Version | TRZ03_MAN_V12_04.2026_00.10.131.02-EN April, 24th 2026 |
| | Language | EN |

CONTENTS

| | | |
|----------|--|-----------|
| 1 | INTRODUCTION..... | 1 |
| 1.1 | OBJECTIVE OF THE MANUAL..... | 1 |
| 1.1.1 | <i>Abbreviations.....</i> | 1 |
| 1.1.2 | <i>Symbols 1</i> | |
| 1.1.3 | <i>Layout of instructions</i> | 2 |
| 1.1.4 | <i>Using the turbine meter TRZ03.....</i> | 3 |
| | 1.1.4.1 Safety instructions 3 | |
| | 1.1.4.2 Hazards during commissioning | 4 |
| | 1.1.4.3 Danger when using, servicing and maintaining..... | 6 |
| | 1.1.4.4 Specialized knowledge required | 7 |
| 1.1.5 | <i>Risk assessment and mitigation.....</i> | 8 |
| 1.1.6 | <i>Validity of the manual</i> | 9 |
| | 1.1.6.1 Hazards during Operation | 10 |
| | 1.1.6.2 Danger during operation in hazardous areas..... | 10 |
| | 1.1.6.3 Operator responsibility10 | |
| 1.1.7 | <i>Transportation.....</i> | 11 |
| 1.1.8 | <i>Delivery 12</i> | |
| 1.1.9 | <i>Dispose of packaging material</i> | 12 |
| 1.1.10 | <i>Storage 12</i> | |
| 1.2 | STRUCTURE OF THE MANUAL..... | 13 |
| 1.3 | OVERVIEW, FUNCTION AND APPLICATION | 13 |
| 1.4 | METHOD OF OPERATION | 16 |
| 1.5 | APPROVALS | 18 |
| 1.6 | STANDARDS / GUIDELINES | 18 |
| 1.7 | VALIDITY OF METER PROVING | 18 |
| 1.8 | MEASURING RANGES..... | 19 |
| 1.8.1 | <i>Extension of the measuring range.....</i> | 19 |
| 1.9 | ACCURACY OF MEASUREMENT | 20 |
| 1.10 | TEMPERATURE RANGES..... | 21 |
| 1.11 | PRESSURE LOSS..... | 22 |
| 1.12 | PRESSURE TAP..... | 23 |
| 1.13 | USING GAS METERS WITH DIFFERENT TYPES OF GASES..... | 23 |
| | 1.13.1 <i>Suitability and safety for natural gas containing H2</i> | 24 |
| 1.14 | INSTALLING THE DEVICE IN THE PIPELINE..... | 25 |
| 2 | INSTALLATION AND COMMISSIONING | 26 |
| 2.1 | INSTALLATION | 26 |
| 2.2 | OPERATING DATA | 28 |
| 2.2.1 | <i>Threshold 28</i> | |
| 2.2.2 | <i>Technical Guideline G 13</i> | 29 |
| 2.2.3 | <i>Perforated-plate straighteners</i> | 30 |
| 2.2.4 | <i>Seals 30</i> | |
| 2.2.5 | <i>Screws 33</i> | |

| | | |
|--------------|---|-----------|
| 3 | TYPES OF TOTALIZERS | 34 |
| 3.1 | TYPE „F“ METER HEAD | 34 |
| 3.2 | TYPE “F-D” METER HEAD | 36 |
| 3.3 | GENERAL | 38 |
| 3.4 | PULSE TRANSMITTERS | 38 |
| 3.4.1 | <i>Connecting additional devices</i> | 40 |
| 3.4.2 | <i>Pulse transmitters in measuring element (HF 2 and HF 3)</i> | 41 |
| 3.4.3 | <i>Connector pin assignments</i> | 42 |
| 3.5 | SPECIFICATIONS OF THE PULSE TRANSMITTERS | 45 |
| 3.6 | TEMPERATURE MEASUREMENT | 46 |
| 3.7 | COMMISSIONING | 47 |
| 3.7.1 | <i>Filling with oil</i> | 47 |
| 3.7.2 | <i>Commissioning ENCO 08 (optional)</i> | 47 |
| 3.7.3 | <i>Connecting the gas flow</i> | 48 |
| 4 | OPERATION | 50 |
| 4.1 | INFLUENCES ON THE ERROR OF MEASUREMENT DUE TO OPERATION | 50 |
| 4.1.1 | <i>Intermittent operation</i> | 50 |
| 4.1.2 | <i>Influence of pulsations</i> | 50 |
| 4.1.3 | <i>Consequences</i> | 51 |
| 4.1.4 | <i>Limiting values</i> | 52 |
| 4.2 | LUBRICATION | 53 |
| 4.2.1 | <i>Lubricator 53</i> | |
| 4.2.2 | <i>Specification for lubricating oils</i> | 54 |
| 4.2.3 | <i>Initial lubrication</i> | 54 |
| 4.2.4 | <i>Relubrication</i> | 54 |
| 4.2.5 | <i>Lubrication procedure</i> | 55 |
| 4.2.6 | <i>Maintenance instructions</i> | 57 |
| 5 | LABELLING | 58 |
| 6 | SPECIFICATIONS | 61 |
| 6.1 | MEASURING RANGES / DIMENSIONS / PRESSURE CLASSES TRZ03 (PTB) | 61 |
| 6.2 | MEASURING RANGES / DIMENSIONS / PRESSURE CLASSES TRZ03-K | 63 |
| 6.3 | Q _{MIN} DEPENDING ON THE OPERATING PRESSURE IN NATURAL GAS | 65 |
| 6.4 | VALUES FOR SECONDARY METERING FOR METERS WITHOUT MID APPROVAL | 66 |
| 6.5 | OVERVIEW OF THE MATERIALS USED | 67 |
| ANNEX | | 68 |
| A. | CERTIFICATES FOR LF-/HF-SENSORS AND ENCODER | 68 |
| B. | CERTIFICATES | 70 |

1 Introduction

1.1 Objective of the manual

The manual provides you with the information that is designed for trouble-free and safe operation.

The TRZ03 is state of the art and conceived and manufactured according to the recognized safety standards and guidelines. However, risks may arise during use that can be easily avoided by observing this manual. For this reason, you may only use the device as intended and in technically sound condition.

| |
|---|
| ⚠ Warning |
| If the TRZ gas meter is not used for its intended purpose, warranty claims will be void. |

1.1.1 Abbreviations

The following abbreviations are used:

| | |
|------------|--|
| ca. | circa, approximately |
| as app. | as applicable |
| max. | maximum |
| MID | Measurement Instruments Directive |
| PED (DGRL) | Pressure Equipment Directive (Druckgeräterichtlinie) |
| min. | minimum |

1.1.2 Symbols

The following symbols are used:

| | |
|-----------|-------------------------------------|
| 1, 2, ... | Marks steps within a work operation |
| .. | |

1.1.3 Layout of instructions

The following instructions are used:

Danger

This warning instruction informs you of potentially hazardous situations that can occur because of incorrect operation or human error. If these situations are not avoided, they can lead to fatal or severest injuries

Warning

This warning instruction informs you of possible hazardous situations that can occur because of incorrect operation or human error. If these situations are not avoided, they can lead to fatal or severe injuries.

Caution

This warning instruction informs you of possible hazardous situations that can occur because of incorrect operation or human error. If these situations are not avoided, they can lead to slight or minor injuries.

Note

This warning instruction informs you of potentially hazardous situations that can occur because of incorrect operation or human error. If these situations are not avoided, they can result in material damage to the device or the vicinity.

This Note may also give to you tips on how to simplify your work. With this screen, you additionally receive further information on the device or the work process.

1.1.4 Using the turbine meter TRZ03

1.1.4.1 Safety instructions

Danger

Observe the following safety instructions!

Non-observance of these safety instructions can lead to a risk of life and limb and health of the person as well as damage to the environment or property damage.

3

Note that the safety instructions in this operating instruction and on the device cannot cover all possible hazardous situations as the combination of different circumstances is impossible to predict. To simply follow the instructions specified may not normally be sufficient enough to ensure for correct operation. Always be observant and also consider the following:

- Before working with the device for the first time, read through this operating instruction and, in particular, follow the safety instructions carefully.
- The operating instruction warns against the residual risks for users, third parties, devices or other material assets. The safety instructions used refer to residual risks that cannot be avoided due to the design.
- Operate the device only in a sound state and when observing the operating instruction.
- Also observe the local legal accident prevention, installation and assembly guidelines.

Note

Always keep the operating instructions within reach for use at the place of installation.

For safe operation, the safety instructions must be observed and followed.

The manufacturer is not responsible for any damage that result as a consequence of not observing the operating instruction.

⚠ Danger

Service and maintenance work or repairs that are not described in the operating instruction must not be carried out without previous consultation with the manufacturer.

Changes to the device are forbidden.

For safe operation, the technical specifications must be observed and followed. Performance limits must not be exceeded (*chapter 6 Specifications*).

For a safe operation, the device must only be used in the scope of its intended use.

Only use the listed set screws, bolts, nuts and gaskets or parts with similar characteristics for the installation of the meter in the pipeline (*chapter 1.14 Installing the device in the pipeline*) The device should only be used under the intended use for safe operation (*chapter 1.3 Overview, Function and Application*).

1.1.4.2 Hazards during commissioning

Initial start up

Initial start-up must only be carried out by especially trained personal (training by RMG) or by service personal from RMG.

Note

After the initial start-up an inspection report shall be drawn up. This, the operation manual and CE declaration of conformity must always be accessible.

As far as possible all the sharp edges have been eliminated on the device. Nevertheless, when working on the personal protective equipment must be used, which must provide the operator.

⚠
Danger

Install the device TRZ03 in accordance with operating instructions. If the TRZ03 is not installed according to the manual, there is possibly an insufficient explosion protection.

The explosion protection expires!

Please take care during the installation to the flow direction marked on the housing by an arrow.

When staff carry out work without sufficient qualification, risks remain understated when working. Explosion or fire may happen. Perform the work only if you have the appropriate qualifications and you are an expert.

If you do not use the appropriate tools and materials, components may be damaged. Use tools that are recommended to you for the job in the operating instructions.

5

| | |
|---|--|
| Mechanical installation | Mechanical installation must only be carried out by the respectively qualified specialist personnel. |
| Electrical installation | Installation on components must only be carried out by qualified electricians. |
| Mechanical and/or electrical installation | The specialist personnel require a training especially for working in potentially explosive environment. Specialist personnel are persons that can verify a training / further education according to DIN VDE 0105, IEC 364 or a similar national standard . |

⚠ Danger

The installation and removal of the TRZ03 or to the TRZ03 connected convertor may only be carried out in an explosion-free, de-pressurized atmosphere. It is important to pay attention to the descriptions of the operation manual during the installation process.

It is generally recommended to ask the RMG Service for any installation or removal.

After working on pressurized components, a control of leaks must be carried out.

All points above have to be considered for any repair and maintenance and in general, when an opening of the meter (convertor) is required.

Parts to lock the flanges, locking screws, fittings and check valves, oil supply and the pressure tap fittings, valves, HF pulse device, protecting pipe and rotating adapter may not be opened during operation.

1.1.4.3 Danger when using, servicing and maintaining

| | |
|--------------------------|---|
| Operating personnel | The operating personnel are to use and operate the device within the scope of the intended purpose. |
| Maintenance personnel | Work on the device must only be carried out by specialist personnel that can carry out the respective work assigned to them as a result of their training, knowledge and experience as well as the applicable regulations. These specialist personnel are familiar with the legal guidelines for accident prevention and can evaluate and avoid possible risks by themselves. |
| Maintaining and cleaning | Maintenance and cleaning must only be carried out by the respectively qualified specialist personnel. |

⚠ Danger

If staff carry out work without sufficient qualification, risks may be underestimated when working. Explosion or fire may happen. If work is carried out in hazardous areas on voltage supporting equipment, resulting sparks may cause an explosion.

⚠ Danger

If the unit is not cleaned in accordance with the operating instructions, the device may be damaged. Clean the unit only in accordance with the operating instructions.

When not using appropriate tools, components can be damaged. The explosion protection expires.

- Clean with a damp cloth!

7

⚠ Danger

The TRZ 03 may only be used as intended!
(chapter 1.3 Overview, Function and Application).

Avoid any use of the TRZ03 as possible climbing aid or attachments of TRZ03 as possible handholds!

1.1.4.4 Specialized knowledge required

Note

Persons working with or on the device must have the following knowledge:

- Training / education for working in potentially explosive environments.
- The ability to correctly assess dangers and risks when using the device.
- Possible dangers are, e.g., components under pressure or the result of incorrect installation.
- Recognize dangers that could be caused by the used flow medium.
- Training / education by RMG for working with gas measuring instruments.
- Education / instruction in all country-specific standards and directives to be observed for work that is to be carried out on the device.

1.1.5 Risk assessment and mitigation

The TRZ03 subjects to risks in its use, which were judged by qualified staff of the company RMG. Risks may arise due to high pressures, more rarely by too low. Even work outside the permissible temperature range can lead to danger. Invalid current and voltage values can trigger explosions in hazardous areas.

8

The risk assessment assumes that when installing or removing a turbine a draining and venting of the pipeline takes place. Thus, and only then no explosive gas mixture is in the pipeline.

Of course (*chapter 1.1.4.4 Specialized knowledge required*) only work by trained personnel are permitted, which is also trained to know proper tools and use only this.

These risks have been considered during the development phase and action were taken to minimize these risks.

Risk mitigation measures:

- All pressurized parts are designed in accordance to AD 2000 regulations, PED Annex 1
- The complete design being pressurized is verified by the TÜV Hessen.
- All pressurized parts are made with material certificate; there is a traceability to the batch tracking of all pressurized parts.
- The mechanical properties of all relevant pressurized components are checked by tensile testing, impact testing and hardness testing.
- In addition, non-destructive testing was applied: X-ray and ultrasonic testing of the meter housing for defects in material, surface crack detection by magnetic particle and dye-penetration.
- With pressure tests 1.5 times of the intended operating pressure the strength of the components were verified; leak test were carried out at 1.1 times of the intended operating pressure. Successful tests were marked.
- The maximum operating pressure is stated on the nameplate of the device, as well as the temperature range. Operation of the device is only permitted within the indicated ranges.

⚠ Danger**For any work in an explosive atmosphere (all areas):**

- The pulse output of the turbine meter has to be connected to intrinsically safe circuits, only.
- For maintenance and repair work only tool must be used, which is approved for Ex zone. 1
- Otherwise, work must be carried out only if there is no explosive atmosphere.
- Danger of ignition caused by impact or friction must be avoided.
- In hazardous areas, the wiring / installation must be performed by trained personnel in accordance to EN 60079-14 and according to national regulations
- Skilled persons are in accordance to DIN VDE 0105 or IEC 364, or comparable standards
- Use only trained and qualified personnel. Work on the measuring system may only be carried out by qualified personnel and must be checked by a specialist supervisor.
- Qualified persons are able to carry out such work. Qualification is valid due to their training, experience or through instruction and their knowledge of relevant standards, regulations, accident prevention regulations and plant conditions for the safety of people. It is essential that these people are able to recognize and avoid possible dangers.

1.1.6 Validity of the manual

This manual describes the turbine meter TRZ03. The TRZ03 is only a part of a complete on-site system. Observe also the instructions of other components of the site system. If you find contradicting instructions, please contact RMG.

Note

Make sure that the performance of the power connector corresponds to the data on the nameplate. Additionally, observe any existing national regulations in the country. Use cable suitable for the cable glands.

⚠ Danger

Perform the work only if you have the appropriate qualifications and you are a trained specialist.

10

1.1.6.1 Hazards during Operation

Please take care of the information provided by the plant manufacturer and/or plant manager.

1.1.6.2 Danger during operation in hazardous areas

Operate the device in perfect and complete condition.

When you perform technical modifications to the instrument, a safe operation can no longer be guaranteed.

⚠ Danger

Use the device only in the original condition. The TRZ003 may be operated in explosion zone 1, but only within the permitted temperatures (*chapter 1.10 Temperature ranges*).

1.1.6.3 Operator responsibility

Take care as plant manager that only sufficiently skilled personnel will work on the device. Ensure that all employees who handle the equipment have read and understood these instructions. Additionally, you are obliged to train staff on a regular basis and to inform them about any dangers. Ensure that any work carried out on the device is done by qualified personnel and checked by responsible specialists. You must establish clearly the responsibilities for installation, operation, troubleshooting, maintenance and cleaning.

Point out to your staff any risks involved when using the device.

1.1.7 Transportation

The device is packaged customized according to the transport requirements.

⚠ Warning

Risk of injury during transport

Any foot screws must be fitted, if they are used as transit protection against rolling and tipping. Take additional care that a rolling and tilting is safely prevented.

To lift the meter only the special lifting eyes / eye bolts may be used. Pay attention to the maximal loads for the lifting devices (*chapter 6 Specifications*) – don't exceed those. Make sure that the load is fastened securely before lifting. Do not stand under lifted loads.

During lifting and/or depositing the device may slip, tip over or fall. Disregarding the maximum load capacity of the lifting device, the device may fall down. For any people standing nearby, there is a significant risk of serious injury.

If the unit is supplied on a Euro pallet, the unit can be transported using a lift truck or a forklift. During the transport the meter has to be protected against shock or vibration.

The meter or its additionally mounted spool pieces are equipped with flanges that are protected with a sticker foil or blind plugs made of plastic. These must be removed completely before installation in the pipeline. Remaining rests of these protections may change the flow pattern and may result in a measurement error! For any transport e.g. for recalibration we ask you to use these protections.

1.1.8 Delivery

Supplied number of parts may differ depending on the optional customer order. "Usually" the following is included in the scope of delivery:

| Teil | Quantity |
|---|----------|
| Turbine meter TRZ 03 | 1 |
| 1 small bottle of oil for lubrication | 1 |
| Manual | 1 |
| Test report | 1 |
| Calibration certificate | 1 |
| Certificat for - Strength 3.1 and - tightness | |
| ... | ... |

1.1.9 Dispose of packaging material

Dispose the packing material in an environmentally friendly way in accordance to the national standards.

1.1.10 Storage

Avoid long periods of storage. Check the device after any storage for damage and functionality. Ask for a check from the RMG service after a storage period for the device of over one year. In this case please send the device to RMG.

Note

**For storage, a dry and protected space has to be provided.
It is important to ensure that all open pipe pieces must be sealed.**

1.2 Structure of the manual

The introduction of this manual contains two parts. In the first part general guidelines are listed; the symbols used and structure of advices are given, but the risk assessment is also issued. In addition, it contains guidelines for the transport and storage of the TRZ03. The second part introduces the operation of TRZ03; there are basic standards listed; pressure and temperature ranges are given limiting the use of the TRZ03.

The second chapter describes the use of TRZ03. It explains how a high accuracy can be achieved. The third chapter describes various totalizer heads, their properties and connection options. The fourth chapter provides recommendations on how the current operation can be ensured. These include the accuracy influencing flow disturbances as well as regular lubrication of the bearings of the turbine meter.

The fifth chapter describes the marking of the TRZ03 and in the sixth the technical data of TRZ03 are summarized. The appendix includes details to the previous chapters, a summary of certificates and approvals.

1.3 Overview, Function and Application

The TRZ 03 turbine meters are flow meters which can be used for custody transfer metering. Or more precisely for measuring the volume at measurement conditions of non-aggressive gases and fuel gases. The TRZ 03-K turbine meter can only be used for secondary metering.

All types of turbine meters measure the quantity of gas flowing through them in units of volume at prevailing pressure and temperature. Therefore, the units of volume are determined at flowing conditions. The volume of the gas flowing through is indicated by a mechanical totalizer in cubic meters at flowing conditions. In addition, the turbine meters can be fitted with HF or LF pulse transmitters and with reed contacts. In this way, pulses are obtained whose number is proportional to the volume which has flowed through. These pulses can be further processed by volume correctors.

The major differences between types TRZ 03 and TRZ 03-K are as follows:

TRZ 03

- Approved for custody transfer metering according to DIN 33800
- Installation length: 3 x DN
- Accuracy $\leq \pm 0.5\%$ (above 0,2 Q_{max})
- Blade monitoring system

TRZ 03-K

- For secondary metering
- Installation length: $\leq 1,5 \times \text{DN}$
- Accuracy $\leq \pm 1\%$ (above $0,2 Q_{\text{max}}$)

The following applies to all meter types:

- Maximum operating pressure: 100 bar (not for gas meters with a plastic turbine wheel)
- Meter sizes from G 40 to G 16000
- Measuring range 1:20 (MID); applying a high-pressure certification, a range of up to 1:160 is also possible (see data sheets)
- Connections in compliance with DIN or ANSI are available.
- Special designs for aggressive gases are available.
- Available for low temperatures ($< 10^{\circ}\text{C}$)
- All gas meters can be operated in any position up to the nominal diameter of DN 200.

The TRZ 03 and TRZ 03-K are used for measuring the volume at measurement conditions of non-aggressive gases and fuel gases. Measurements of aggressive gases are only permitted if the special designs are used which have been developed for this purpose.

The TRZ 03 und TRZ 03-K are approved for the use in explosive areas; the indication is:



II 1G Ex ia IIC T4 (HF sensors)

The corresponding conformity certificates for the LF und HF sensors can be found in the appendix.

Information about temperature limits are given in *chapter 1.10 Temperature ranges*.

The TRZ 03 meets the standards, guidelines and regulations:

⇒ *Chapter 1.6 Standards / Guidelines and the Annex*

These technical limitations you must comply with the TRZ03 for safe operation:

⇒ *Chapter 6 Specifications*

The device may only be operated with the following types of gases (*chapter 1.13 Using gas meters with different types of gases*). Only with these stated gases a safe operation is ensured:

- Gases of class 1
- Gases of class 2
- Gases of class 3

15

The friction of the gas components must be within the limits in accordance with the EN 437:2009 for test gases.

The following instructions must be observed:

Note

The RMG TRZ 03 und TRZ 03-K can be operated in any mounting orientation up to DN200, from the DN 250 a horizontal orientation is required.

If a mounting orientation is specified when ordering, the meter has to be installed in this orientation.

It is also important to ensure that the filling port of the lubricator faces upwards.

1.4 Method of operation

The method of operation of the mechanical turbine meter is based on the measurement of the gas velocity. The velocity of the gas flowing through the gas meter is increased in the flow straightener and the gas strikes the turbine wheel in a defined flow cross section. In the flow straightener, unwanted vortices, turbulences and asymmetries are removed or reduced. The turbine wheel is mounted axially, while the blades of the turbine wheel are arranged at a certain angle to the gas flow. Within the measuring range (Q_{\min} - Q_{\max}), the rotational speed of the turbine wheel is almost proportional to the mean gas velocity and, therefore, to the rate of flow. The number of rotations is a measure of the volume that has flowed through. The rotary movement of the turbine wheel is transmitted by a magnetic coupling to the unpressurized meter head. Downstream of the coupling, there is an HF pulse transmitter (HF 1) and gearing which reduces the rotational speed of the turbine wheel to match the mechanical totalizer. An LF pulse transmitter (slot-type initiator or reed contact) is located on the totalizer.

Figure 1: Sectional drawing of a turbine meter shows a sectional drawing of a turbine meter TRZ03. Downstream of the turbine wheel, a cam wheel (reference wheel) is located on the same shaft. Two HF sensors (proximity switches) generate a signal if a blade of the turbine wheel (HF 3) or a cam of the reference wheel (HF 2) passes them. In this way, two pulse sequences are generated which are out of phase. The generated pulses can be further processed for secondary volume measurements or flow measurements.

A counter with an integrated encoder (e.g. ENCO 08) processes the pulse sequences. The totalizer (V_0) can be transmitted digitally to a flow computer. The necessary pressure and temperature values can be recorded in the pr connection (pressure) and via one (or more) temperature sensors in the immersion pocket.

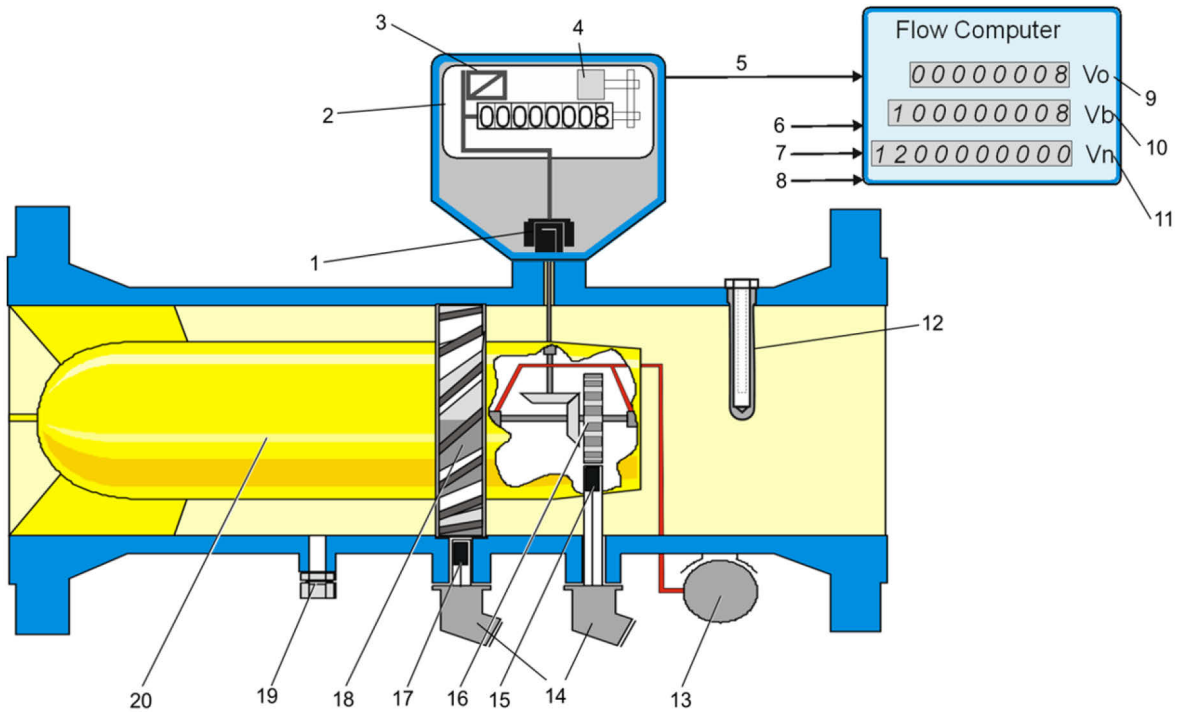

Figure 1: Sectional drawing of a turbine meter

| No. | Designation | No. | Designation |
|-----|--|-----|---------------------------------------|
| 1 | Magnetic coupling | 11 | Vn (flow rate at standard conditions) |
| 2 | Mechanical counter | 12 | Thermowell for temperature sensor |
| 3 | LF 1/2 MK (low frequency) | 13 | Oil pump |
| 4 | ENCO 08 transmitter for totalizer | 14 | HF 2/3 (high frequency) |
| 5 | Data transmission line | 15 | High frequency pulse transmitter |
| 6 | LF (low frequency) | 16 | Reference wheel |
| 7 | HF2d (high frequency) | 17 | High frequency pulse transmitter |
| 8 | HF3D (high frequency) | 18 | Turbine wheel |
| 9 | Vo (original counter) | 19 | Pr connection (pressure) |
| 10 | Vm (flow rate at measuring conditions) | 20 | Flow straightener |

1.5 Approvals

Type **TRZ 03** has been approved for custody transfer metering. The following approvals have been obtained:

- | | |
|---|---|
| • MID – approval number | No. T10417 |
| • DGRL2014/68/EU / (PED-approval) approval number | No. ISG-22-12-1980 (TRZ 03) and ISG-22-12-1994 (TRZ 03-K) |

Independent whether a turbine meter can be remotely read (via the encoder) it is fitted with a metrologically controlled mechanical index. The reading of this index is the measurement result that serves as the basis for billing.

Type **TRZ 03-K** has not been approved for custody transfer metering.

1.6 Standards / Guidelines

All RMG turbine meters have passed the disturbance measurements in compliance with OIML Recommendation IR-32/89, Annex A, with slight and heavy flow disturbances. Therefore, this meter design meets the requirements for installation in compliance with Technical Guideline G 13 Sec. 1. Test specifications are as laid down in PTB Testing Instructions, Vol. 29 and 30, Testing of volume gas meters with air under atmospheric and high pressure.

The RMG turbine meters of type TRZ 03 comply with EN12261, as well as to the MesseV MID (2014/32/EU).

1.7 Validity of meter proving

The turbine meters of type TRZ 03 which are suitable for custody transfer metering must be subjected to subsequent meter proving at regular intervals. The validity of meter proving is determined in the German Metering and Calibration Rules (MesseV, Edition 11, December 2014) with the following periods:

| | |
|--|-----------|
| Turbine meters without lubricator | 8 years |
| Turbine meters with flow range 65 m ³ /h to ≤ 4.000 m ³ /h | 12 years |
| Turbine meters with flow range > 4.000 m ³ /h to < 16.000 m ³ /h | 16 years |
| Turbine meters with flow range ≥ 16.000 m ³ /h | unlimited |

Note

For reverification the meter has to be removed and tested at a test rig.

1.8 Measuring ranges

The measuring ranges are between 10 and 25,000 m³/h (flowing conditions). A measuring range is specified for each meter size. It is limited by the minimum flow rate Q_{\min} and the maximum flow rate Q_{\max} (*chapter 6.1 Measuring ranges / Dimensions / Pressure classes TRZ03 (PTB) and 6.2 Measuring ranges / Dimensions / Pressure classes TRZ03-K*).

For types TRZ 03 this is the flow range where the gas meter must indicate correct values within the error limits specified by the German Metering and Calibration Rules.

Turbine meters of type TRZ 03 have measuring ranges up to 1:30 even under atmospheric pressure. If a high-pressure test is conducted in compliance with Technical Guideline G 71) (PTB), the measuring range can be extended to 1:50. Then the minimum flow rate Q_{\min} HP is the lowest test point during high-pressure testing. Types TRZ 03 may then be used for billing purposes within the specified HP flow and density ranges.

The measuring range of type TRZ 03-K is 1:20 or 1:16.

1.8.1 Extension of the measuring range

In the range of $0.2 Q_{\max}$ to Q_{\max} , the measuring behaviour of turbine meters is determined by the aerodynamic conditions in the flow channel and the measuring cross section. By means of many series of tests conducted both under atmospheric pressure and under higher pressures and with an appropriate rating for such ranges, it is possible to achieve a deviation of the calibration curve under atmospheric conditions and under high-pressure conditions of $< 0.5\%$ in the flow range of $0.2 Q_{\max}$ to Q_{\max} .

In the lower flow range, the measuring behaviour is determined by the relationship between the gas flow driving the measuring wheel and the slowing-down torques due to drags (bearings and totalizer). The driving torques increase linearly with the density and quadratically with the velocity of the gas to be measured. Due to the physical conditions, the measuring range is therefore enlarged in relation to the density. The lower flow limit shifts in the direction of smaller loads (see also table in *chapter 6.3 Q_{\min} depending on the operating pressure in natural gas*). Use the formula below as approximate equation:

$$Q_{md} \approx Q_{min} \cdot \sqrt{\frac{1,2}{\rho}} \quad (m^3 / h)$$

The density ρ can be determined with the following approximate formula:

$$\rho \approx (p_m + 1) \cdot \rho_n \quad (kg / m^3)$$

The influence of the temperature is not taken into account in this formula.

With:

Q_{md} : Minimum flow rate at flowing conditions

Q_{min} : Minimum flow rate of the gas meter

p_m : Operating pressure in bar

ρ : Density in kg/m^3 (density of air at 20° C and 1,01325 bar $\approx 1,2 kg/m^3$)

ρ_n : Standard density of the gas (standard density of natural gas $\approx 0,8 kg/m^3$)

1.9 Accuracy of measurement

The following error limits apply within the permissible measuring range:

| Measuring range: | Q_{min} to 0,2 Q_{max} | 0,2 Q_{max} to Q_{max} |
|---------------------------------|---|----------------------------|
| Calibration limit ¹⁾ | $\pm 2 \%$ | $\pm 1 \%$ |
| TRZ 03 | $\pm 1 \%$ | $\pm 0,5 \%$ |
| TRZ 03-K | $\pm 3 \%$ (DN 50, DN 80: $\pm 4 \%$) | $\pm 1,5 \%$ |

1) maximum error due to the German Metering and Calibration Rules

It will be checked whether these limits are observed. They also apply to the high-pressure range.

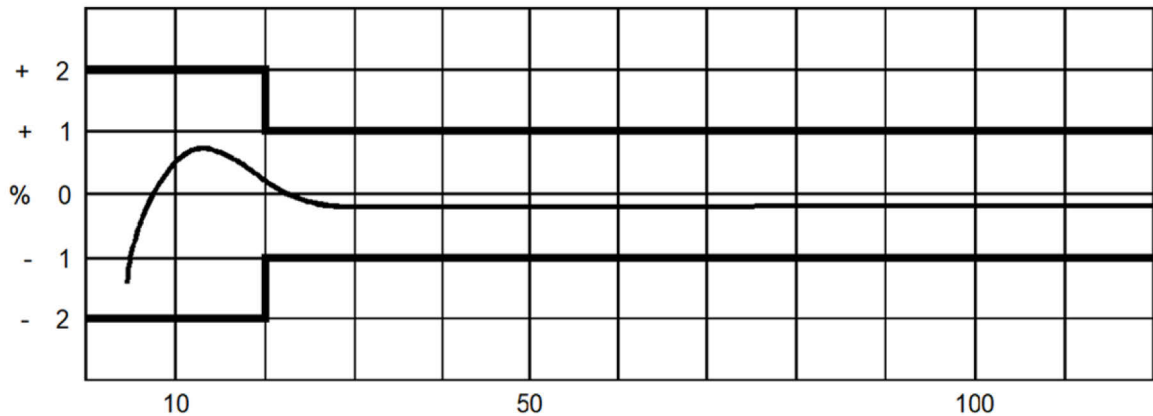

21

Figure 2: Calibration curve of a turbine meter

The reproducibility, i.e. the difference between the results of two measurements Under identical conditions, is as follows:

TRZ 03, TRZ 03-K: $\leq \pm 0,1\%$

1.10 Temperature ranges

For the standard designs of the turbine meters of types TRZ 03 and TRZ 03-K, the following temperature ranges are permitted:

MID:
 -25°C to +55°C (TRZ 03 for custody transfer metering)

DGRL2014/68/EU (PED):
 -20°C to +80°C (Spheroidal graphite iron)
 -40°C to +80°C (cast steel)

ATEX:
 -25°C to +70°C (T4)

Note
 For different values the lowest range applies.

1.11 Pressure loss

The pressure loss of RMG turbine meters has been reduced to a minimum thanks to modifications with regard to design. The measuring points for pressure loss are located 1 x DN upstream and downstream of the gas meter. The pressure loss is calculated using the following formula:

$$\Delta p = Z_p \cdot \rho_m \cdot \frac{Q_m^2}{DN^4}$$

where:

| | | |
|------------|--|----------------------|
| Δp | pressure loss | [mbar] |
| Z_p | pressure loss coefficient | |
| ρ_m | density | [kg/m ³] |
| Q_m | volume flow rate at measurement conditions | [m ³ /h] |
| DN | is the nominal diameter of the gas meter | [mm] |

| Device type | Z_p |
|---|-------|
| Turbine meter TRZ 03 / TRZ 03-K / TME 400: | |
| DN 50 | 3900 |
| DN 80 | 4870 |
| DN 100-150 | 3520 |
| DN 200-600 | 2540 |
| L1 perforated-plate straightener as per ISO/DIN | 3150 |
| L2 perforated-plate straightener as per ISO/DIN | 6300 |
| L3 perforated-plate straightener as per ISO/DIN | 9450 |
| LP-35 perforated-plate straightener as per RMG-Norm | 1260 |
| RB 19 tube-bundle straightener as per ISO/DIN | 1260 |
| Tube | 80 |

The values for Z_p are approximate mean values. The exact value is calculated from the pressure loss, which is determined during testing the turbine meter.

Example of calculation of the pressure loss for a turbine meter with upstream perforated-plate straightener LP-35:

TRZ 03 DN 150/G650, $Q_{max} = 1000 \text{ m}^3/\text{h}$
 Medium: Natural gas ($\rho_b = 0,83 \text{ kg/m}^3$ at base conditions)
 Pressure: 10 bar g
 Flow rate at measured conditions: $Q_m = 650 \text{ m}^3/\text{h}$

From the table on the previous page you may find:

$$Z_p(\text{TRZ 03}) = 3520$$

$$Z_p(\text{LP-35}) = 1260$$

$$Z_p(\text{Tube}) = 80 \times (2 \times \text{DN}) = 24$$

$$\begin{aligned} \text{Calculation: } Z_p(\text{total}) &= 3520 + 1260 + 24 \\ &= 4804 \end{aligned}$$

$$\begin{aligned} \Rightarrow \Delta p &= 4804 \cdot (0,83 \cdot 11) \cdot \frac{650^2}{150^4} \\ &= \underline{\underline{36,6 \text{ mbar}}} \end{aligned}$$

1.12 Pressure tap

A pressure tap has been provided to connect the pressure transducer of a volume corrector or a pressure gauge to read the pressure at measurement conditions prevailing inside the gas meter. This pressure tap is identified by “p_r”.

1.13 Using gas meters with different types of gases

| Gas type | Symbol | Density at 0°C 1,013 bar | Meter housing | Comments |
|--------------------|---------------------------------|-----------------------------|---------------|---------------------------|
| Acid gas | | | Special | Special measuring element |
| Air | | 1,29 | Standard | |
| Ammonia | NH ₃ | 0,77 | Standard | O-rings / lubrication |
| Argon | Ar | 1,78 | Standard | |
| Butane | C ₄ H ₁₀ | 2,70 | Standard | |
| Carbon dioxid | CO ₂ | 1,98 | Standard | Excepcion: food industry |
| Carbon monoxid | CO | 1,25 | Standard | |
| Ethan | C ₂ H ₆ | 1,36 | Standard | |
| Ethylene (gaseous) | C ₂ H ₄ | 1,26 | Standard | Special design |
| Freon (gaseous) | CCl ₂ F ₂ | 5,66 | Standard | O-rings / lubrication |
| Helium | He | 0,18 | Standard | Reduced measuring range |

| Gas type | Symbol | Density at 0°C 1,013 bar | Meter housing | Comments |
|--------------------------|--------------------------------|-----------------------------|---------------|---------------------------|
| Hydrogen | H ₂ | 0,09 | Special | Reduced measuring range |
| Hydrogen sulphide (0,2%) | H ₂ S | 1,54 | Special | Special measuring element |
| Methane | CH ₄ | 0,72 | Standard | |
| Nitrogen | N ₂ | 1,25 | Standard | |
| Oxygen (100%) | O ₂ | 1,43 | Standard | Special design |
| Pentane | C ₅ H ₁₂ | 3,46 | Standard | |
| Propane | C ₃ H ₈ | 2,02 | Standard | |
| Propylene (gaseous) | C ₃ H ₆ | 1,92 | Standard | Special measuring element |
| Sulfur dioxide | SO ₂ | 2,93 | Special | Special design |
| City gas | | | Standard | |

1.13.1 Suitability and safety for natural gas containing H₂

The TRZ 03(-K) can be used in hydrogen-containing natural gas up to pure hydrogen. There are no safety-related concerns for this use.

Note

In accordance with the German TR-G19 – the TRZ03 is suitable and approved for use in custody transfer applications – in natural gases with a maximum hydrogen content of 30 mol-%, with the accuracy specified in *chapter 1.9 Accuracy of measurement*.

Since there are currently no certified test rigs in Germany to calibrate meters with higher hydrogen-containing gases, an accuracy above 30 mol-% cannot be tested or certified.

Not custody transfer measurements are of course possible in natural gases with a hydrogen content above 30 mol%. However, a reduced measuring range must be taken into account if applicable. Please contact RMG for further information.

1.14 Installing the device in the pipeline

The units of RMG are equipped with flanges. The flange connections for the connected pipes must comply with the connecting dimensions of the flanges of the unit:

- ANSI-pressure levels: Flange in accordance with ASME B 16.5.
- DIN-pressure levels: Flange in accordance with DIN EN 1092.

25

Danger

Gas leakage for the wrong gaskets. If wrong flange gaskets are used for connecting turbine gas meters, gas may flow through leaks resulting in an explosive gas mixture.

Poisoning and explosion hazard!

In addition, the stress of the flange is increased inadmissible when tightening the bolts.

Make sure that no flange gaskets are protruding into the pipe.

Pay attention to a save mounting / hanging-up of the TRZ03 during assembly to avoid the risk of bruising. Avoid having your fingers (or other body parts) between any openings and gaps that are moved together when tightening the flanges!

Note

When installing the meter, take care of the flow direction indicated by an arrow on the body.

Malfunction may be caused due to incorrect gaskets.

When wrong flange gaskets are used for turbine meters, which protrude into the pipe, the measurement accuracy may be affected.

Make sure that the flange gaskets on the sealing surfaces are not protruding into the pipe.

The stability of the flange connection for gaskets and bolts with certain material properties (see *chapter 2.2.4 Seals* and *chapter 2.2.5 Screws*) was proved to AD2000 regulations.

- Other screw / flange - variants were not verified.

2 Installation and Commissioning

2.1 Installation

Note

Any components affecting the gas flow must be avoided directly upstream of the turbine meter (see DVGW Guideline G 492II and PTB Guideline G13).

An inlet pipe of a minimum of $2 \times \text{DN}$ is required upstream of the RMG TRZ 03 turbine meter. The inlet pipe must be designed as a straight pipe section of the same nominal diameter as the gas meter. If there is a heavy flow disturbance, it is necessary to use flow straighteners (see table on next page). A pipe or fitting (bend) of the same nominal diameter as the gas meter and an overall length of $2 \times \text{DN}$ must be installed downstream of the gas meter.

Temperature measuring instruments may only be installed at a distance of $1 \times \text{DN}$ or in the case of nominal diameters of $\geq \text{DN } 300$ at a minimum distance of 300 mm.

If there are flow disturbances (e.g. due to a gas pressure regulator) upstream of the inlet pipe, it is also necessary to use a perforated-plate straightener. You can use perforated-plate straighteners complying with ISO 5167-1 or of type RMG LP-35, the latter resulting in a pressure loss which is 2.5 times lower than that of the standardized flow straightener.

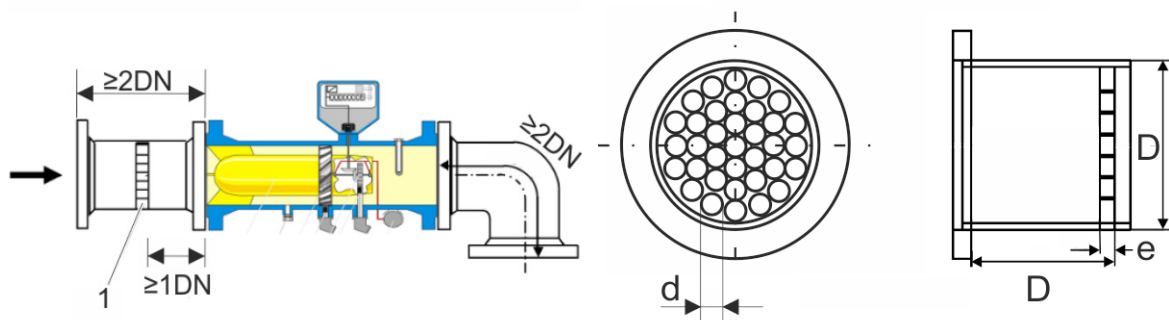

1 Perforated Plate Straightener

Perforated Plate Straightener LP-35

- The opening angle of reducers or expansion fittings installed upstream of a turbine meter of type TRZ 03 or TRZ 03-K must not exceed 30° .

In order to obtain precise measurement results, the turbine meter must be installed in the gas line in such a way that no seals protrude from the flanges into the pipeline.

Note

A protective screen should be installed on the intake side of the gas meter to protect the turbine meter against any foreign particles possibly contained in the gas flow. The protective screen can be a perforated plate of sheet metal with a hole diameter of 3 mm which is available from RMG.

- The pm tap which is located on the RMG turbine meter is the pressure-measuring point which was used for taking the relevant pressure at measurement conditions during meter proving. This pressure-measuring point is used for connecting pressure measuring instruments such as flow computers or volume correctors. Other connection options (e.g. for temperature measurement) can be supplied on a pipe section on the output side of the gas meter.

⚠ Danger

Protect the turbine meter from damage caused by heavy flow variations, e.g. if the downstream pipeline system must be filled or blown off.

If it is necessary to do welding work on the gas line, such work can only be performed at a safe distance from the gas meter. Extreme temperatures prevailing in the gas line in the proximity of the gas meter can result in a permanent damage to the gas meter.

All electrical connections between the gas meter and the amplifiers or the flow computer must be carried out in compliance with the installation instructions. Make sure that these connections are intrinsically safe.

Any liquids remaining in the gas line after hydrostatic testing can damage the interior parts of the gas meter. If hydrostatic testing is necessary, the turbine meter must be replaced by a pipe section. Make sure that no liquid remains in the gas line upstream of the gas meter after hydrostatic testing.

2.2 Operating data

2.2.1 Threshold

Recommended threshold values for maximum service life and maximum accuracy:

28

| Note | |
|--------------------------------|--|
| Maximum overload: | < 20% above Q_{\max} for a short time (< 30 sec) |
| Maximum flow or shock loads | < $0.01 \cdot Q_{\max}/\text{sec} \hat{=} 1\%$ of Q_{\max}/sec e.g. starting up 0 - 100%: > 100 sec |
| Maximum pressure change: | < 0.1 bar/sec |
| Maximum flow pulsation: | < 5% |
| Particle size in the gas flow: | < 5 μm |
| Lubrication of bearings | See <i>chapter 4.2 Lubrication</i> . Lubrication intervals depend on the condition of the gas (condensate, rust or dust) |
| Vibration / mechanical shock: | < 1 mm/sec (vibration velocity) |

These specified data must be determined and checked during commissioning, prior to filling and during the start-up and running-in phases of the gas meters. If more than one threshold value occurs at the same time, appropriate action must be taken in the station to improve the measuring conditions.

| Note |
|---|
| <p>The operator must record all measuring data (gas meter and operating data) during the whole period of operation in order to detect the causes of a possible destruction of the gas meter at an early stage and take corrective action in good time.</p> <p>Corrective action or reduction of the critical operating conditions can be achieved by the following measures for example:</p> <ul style="list-style-type: none"> • Start-up screens (mesh width < 0.15 mm) • Filters • Perforated plates (\varnothing 3 - 4 mm) protecting the gas meter • Valves with control drive mechanism (flow variation) • Non-return valves (pulsation and return flow) |

2.2.2 Technical Guideline G 13

The installation conditions for new stations complying with TRG G 13 and the simpler installation conditions for RMG turbine meters are compared in the table below.

| Type of flow disturbance | Installation conditions as per TR G13 | Installation conditions for RMG gas meters Type TRZ03 | Comments |
|---|--|---|--|
| None | Inlet pipe ≥ 5 DN Outlet pipe ≥ 2 DN | Inlet pipe ≥ 2 DN Outlet pipe ≥ 2 DN | The outlet pipe can also be designed as a bend. |
| | Inlet pipe ≥ 10 DN | | Flow disturbances upstream of this inlet pipe need not be considered, if the requirement for an alternating and pulsating flow is fulfilled. |
| Bend | Inlet pipe ≥ 5 DN | Inlet pipe ≥ 2 DN | |
| Space bend | Inlet pipe ≥ 5 DN and additionally, 2 perforated-plate straighteners or one tube-bundle straightener | Inlet pipe ≥ 2 DN | |
| Gas pressure regulator with sound attenuator | Inlet pipe ≥ 5 DN | Inlet pipe ≥ 2 DN and additionally, 1 perforated-plate straightener | |
| Gas pressure regulator without sound attenuator | Inlet pipe ≥ 5 DN and additionally, 2 perforated-plate straighteners | Inlet pipe ≥ 2 DN and additionally, 1 perforated-plate straightener | |
| Diffuser | Inlet pipe ≥ 5 DN and additionally, 1 perforated-plate straighteners | Inlet pipe ≥ 2 DN | |
| Diffuser with swirling flow | Inlet pipe ≥ 5 DN and additionally, 2 perforated-plate straighteners | Inlet pipe ≥ 2 DN | |

2.2.3 Perforated-plate straighteners

There are the following options for flow straighteners:

RMG L1 – L3 perforated-plate straighteners
complying with ISO 5167-1 and DIN 1952

RMG LP-35 perforated-plate
straightener

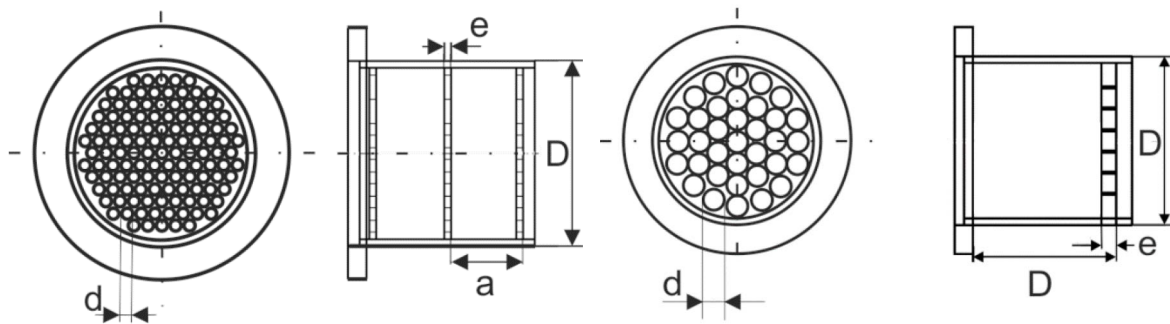

| Features | ISO / DIN | L1 to L3 | RMG LP-35 |
|--------------------------------|-------------------------|-------------------------|-------------------------|
| Hole diameter d | $d \leq 0.05 D$ | 0.04 D | 0.13 D |
| Plate thickness e | $e \geq d$ | $e = d$ | 0.13 D |
| Plate clearance a | $0.5 D \leq a \leq 1 D$ | 0.5 D | - |
| Opening ratio m | $0.2 \leq m \leq 0.4$ | 0.3 | 0.6 |
| Pressure loss, dyn. Δp | | $5 - 15 (c^2 \rho / 2)$ | $2 - 15 (c^2 \rho / 2)$ |

In conjunction with RMG turbine meters, these flow straighteners fulfil the requirements of Technical Guideline G 13 and are approved under EU approval No. D 81 / 7.211.10 for turbine meters.

2.2.4 Seals

It must be guaranteed that flange seals of RMG turbine meters do not protrude from the flange into the gas line.

All seals approved as per AD2000-Regelwerk can be used depending on the requirements for stability and reliability.

- gaskets: $k_0 \times K_D = 20 \times b_D \mid k_1 = 1.3 \times b_D \text{ [N/mm]}$
- grooved seals: $k_0 \times K_D = 15 \times b_D \mid k_1 = 1.1 \times b_D \text{ [N/mm]}$
- spiral seals: $k_0 \times K_D = 50 \times b_D \mid k_1 = 1.4 \times b_D \text{ [N/mm]}$
- octagonal ring joint seal: $K_D = 480 \text{ N/mm}^2$

For recommended dimensions, see the tables below.

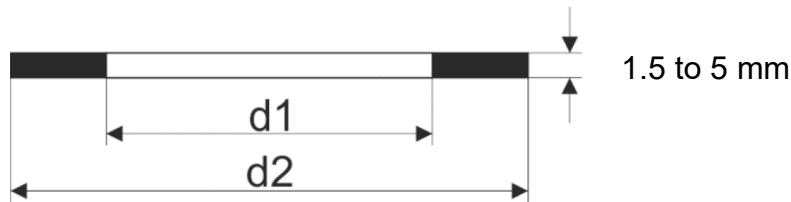

| Gaskets | | | PN 10 | PN 16 | ANSI 150 | PN 25 | PN 40 |
|---------|-----|-----|-------|-------|----------|-------|-------|
| DN | | d1 | d2 | | | | |
| 50 | 2" | 77 | 107 | 107 | 105 | 107 | 107 |
| 80 | 3" | 90 | 142 | 142 | 137 | 142 | 142 |
| 100 | 4" | 115 | 162 | 162 | 175 | 168 | 168 |
| 150 | 6" | 169 | 218 | 218 | 222 | 225 | 225 |
| 200 | 8" | 220 | 273 | 273 | 279 | 285 | 292 |
| 250 | 10" | 274 | 328 | 330 | 340 | 342 | 353 |
| 300 | 12" | 325 | 378 | 385 | 410 | 402 | 418 |
| 400 | 16" | 420 | 490 | 497 | 514 | 515 | 547 |
| 500 | 20" | 520 | 595 | 618 | 607 | 625 | 628 |
| 600 | 24" | 620 | 695 | 735 | 718 | 730 | 745 |

| Grooved seals | | ANSI 300 / ANSI 600 | | PN 64 | |
|---------------|-----|---------------------|-------|-------|-----|
| DN | | d1 | d2 | d1 | d2 |
| 50 | 2" | 69.8 | 88.9 | 65 | 87 |
| 80 | 3" | 98.4 | 123.8 | 95 | 121 |
| 100 | 4" | 123.8 | 154.0 | 118 | 144 |
| 150 | 6" | 177.8 | 212.7 | 170 | 204 |
| 200 | 8" | 228.6 | 266.7 | 220 | 258 |
| 250 | 10" | 282.6 | 320.7 | 270 | 315 |
| 300 | 12" | 339.7 | 377.8 | 320 | 365 |
| 400 | 16" | 422.3 | 466.7 | 426 | 474 |
| 500 | 20" | 530.2 | 581.0 | 530 | 578 |
| 600 | 24" | 631.8 | 682.6 | 630 | 680 |

| Spiral seals | | ANSI 300 | | PN 64 | | ANSI 600 | |
|--------------|-----|----------|-------|-------|-----|----------|-------|
| DN | | d1 | d2 | D1 | d2 | d1 | d2 |
| 50 | 2" | 69.9 | 85.9 | 66 | 84 | 69.9 | 85.9 |
| 80 | 3" | 101.6 | 120.7 | 95 | 119 | 101.6 | 120.7 |
| 100 | 4" | 127.0 | 149.4 | 120 | 144 | 120.7 | 149.4 |
| 150 | 6" | 182.6 | 209.6 | 174 | 200 | 174.8 | 209.6 |
| 200 | 8" | 233.4 | 263.7 | 225 | 257 | 225.6 | 263.7 |
| 250 | 10" | 287.3 | 317.5 | 279 | 315 | 274.6 | 317.5 |
| 300 | 12" | 339.9 | 374.7 | 330 | 366 | 327.2 | 374.7 |
| 400 | 16" | 422.4 | 463.6 | 426 | 466 | 412.8 | 463.6 |
| 500 | 20" | 525.5 | 577.9 | 530 | 574 | 520.7 | 577.9 |
| 600 | 24" | 628.7 | 685.8 | 630 | 674 | 628.7 | 685.8 |

2.2.5 Screws

The stability of the flange connection was verified using the screws listed in this section in combination with the seals listed in the previous section. Other screw / flange variants were not verified.

| | Temperature ranges for screws and nuts | | | |
|----------------------------|--|--|--|---|
| | -10°C to +80°C | -40°C to +80°C | | |
| Pressure | | Variant 1 | Variant 2 | Variant 3 |
| up to and including 40 bar | Screws complying with DIN EN ISO 4014 made of material 5.6, Nuts complying with DIN EN ISO 4032 made of material 5-2 | Screws complying with DIN EN ISO 4014 made of material 25CrMo4, Nuts complying with DIN EN ISO 4032 made of material 25CrMo4 | | |
| from 40 bar | Screw bolts complying with ANSI B1.1 made of material ASTM A193 Grade B7, Nuts complying with ANSI B1.1 made of material ASTM A194 Grade 2H | Screw bolts complying with ANSI B1.1 made of material ASTM A320 Grade L7, Nuts complying with ANSI B1.1 made of material ASTM A320 Grade L7 | Screw bolts complying with ANSI B1.1 made of material 42CrMo4, Nuts complying with ANSI B1.1 made of material 42CrMo4 | Anti-fatigue bolts complying with DIN 2510 made of material 25CrMo4, Nuts complying with DIN 2510 made of material 25CrMo4 |

Expansion bolts may only be used on devices within the scope of the Pressure Gauge Directive.

3 Types of totalizers

The RMG turbine meter TRZ 03 can be fitted with different totalizers.

3.1 Type „F“ meter head

The current standard design is type “F” meter head without mechanical drive shaft couplings. You can see this design in *Figure 3: Type “F” meter head*. Optionally, an ENCO 08 encoder can also be integrated in the meter head (see *Figure 4: Encoder ENCO 08 integrated in meter head type “F”*). In addition to the direct recording and display of the operating volume flow, this design allows digital transmission to a flow computer for calculating the standard volume flow rate. The necessary pressure and temperature values can also be recorded, as shown in *Figure 1: Sectional drawing of a turbine meter*.

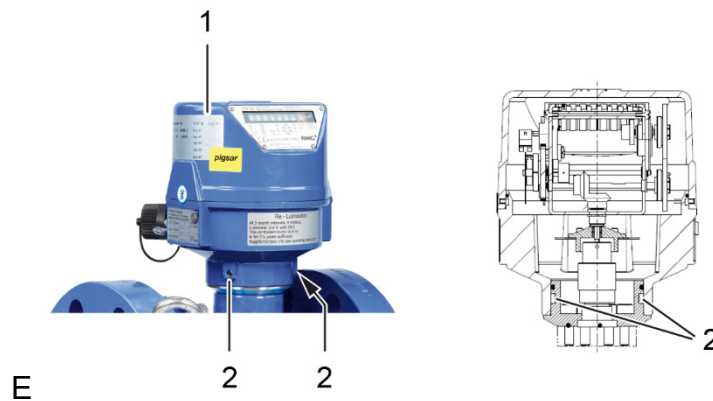

Figure 3: Type “F” meter head

| No. | Designation | No. | Designation |
|-----|-------------|-----|---------------|
| 1 | Meter head | 2 | Locking Screw |

Note

This design provides no options for connecting additional mechanical equipment.

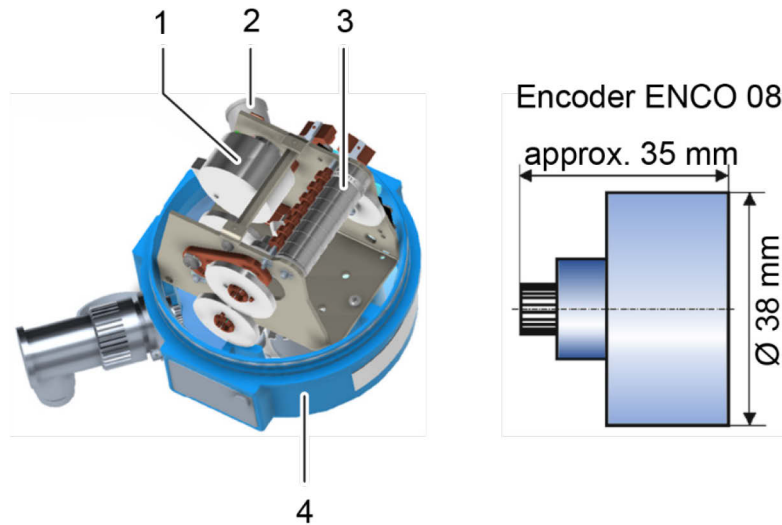
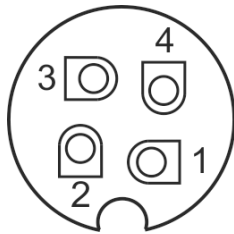

Figure 4: Encoder ENCO 08 integrated in meter head type "F"

| No. | Designation | No. | Designation |
|-----|-----------------|-----|--|
| 1 | Encoder ENCO 08 | 2 | Encoder output connector (type: Binder Series 713) |
| 3 | Digital index | 4 | Meter head |



The ENCO-08 output connector is 3-pole and has the assignment:

- 1 – Vo (+)
- 2 – --- (not used)
- 3 – Vo (-)
- 4 – PE (protective earth)

The totalizer has the following features:

- LF pulse transmitter
 - Standard: reed-contact
 - Alternatively: inductive pulse transmitter
 - Option: up to two additional inductive LF pulse transmitters
- HF pulse transmitters are optionally available, pulse frequency approx. 100 Hz at Q_{max}
- IP 65 Protection class
- Universal readable
- Totalizer unit and HF 1 pulse transmitter are easily replaceable on site.

Note

The electrical connector must be covered by a cap closure or a connecting plug! Otherwise moisture may ingress into the meter head.

3.2 Type “F-D“ meter head

Design and features like in the case of the type “F” meter head but additional with a mechanical drive shaft in compliance with EN 12261 on the top side of the case.

The direction of rotation of the drive shaft (with view on the drive shaft) is clockwise.



Figure 5: Type “F-D“ meter head

For dimensions and instructions for the connection see the description of the type “D” meter head (see below).

Note

Especially note the maximum permissible torques (see the table below)!

Permissible torques (type “F-D”)

| Nominal diameter | Sizes | Q _{max} | Q _{min} [m ³ /h] | | | M _{max} [Nmm] | | |
|------------------|----------|------------------|--------------------------------------|------|-------------------|------------------------|------|------|
| | | | DN | G | m ³ /h | 1:20 | 1:10 | 1:5 |
| 50 | 40 | 65 | - | - | 13 | - | - | - |
| 50 | 65 | 100 | - | 10 | 20 | - | - | - |
| 80 | 100 | 160 | 8 | 16 | 32 | - | 1,0 | 2.0 |
| 80 | 160 | 250 | 13 | 25 | 50 | 1,4 | 2,4 | 3.9 |
| 80 | 250 | 400 | 20 | 40 | 80 | 1,4 | 2,3 | 3.9 |
| 100 | 160 | 250 | 13 | 25 | 50 | 0,14 | 0,6 | 1.3 |
| 100 | 250 | 400 | 20 | 40 | 80 | 0,5 | 1,1 | 2.1 |
| 100 | 400 | 650 | 32 | 65 | 130 | 0,8 | 1,6 | 3.3 |
| 150 | 400 | 650 | 32 | 65 | 130 | 0,5 | 1,5 | 2.4 |
| 150 | 650 | 1000 | 50 | 100 | 200 | 1,3 | 2 | 3.3 |
| 150 | 1000 | 1600 | 80 | 160 | 320 | 11,5 | 15,7 | 37.3 |
| 200 | 1000 | 1600 | 80 | 160 | 320 | 11 | 15 | 37 |
| 200 | 1600 | 2500 | 130 | 250 | 500 | 11 | 15 | 37 |
| 250 | 1000 | 1600 | 80 | 160 | 320 | 11 | 15 | 37 |
| 250 | 1600 | 2500 | 130 | 250 | 500 | 11 | 15 | 37 |
| 250 | 2500 | 4000 | 200 | 400 | 800 | 11 | 15 | 37 |
| 300 | 2500 | 4000 | 200 | 400 | 800 | 11 | 15 | 37 |
| 300 | 4000 | 6500 | 320 | 650 | 1300 | 11 | 15 | 37 |
| 300 | 4000-45 | 6500 | 320 | 650 | 1300 | 11 | 15 | 37 |
| 400 | 4000 | 6500 | 320 | 650 | 1300 | 11 | 15 | 37 |
| 400 | 6500 | 10000 | 500 | 1000 | 2000 | 11 | 15 | 37 |
| 400 | 6500-45 | 10000 | 500 | 1000 | 2000 | 11 | 15 | 37 |
| 500 | 6500 | 10000 | 500 | 1000 | 2000 | 11 | 15 | 37 |
| 500 | 10000 | 16000 | 800 | 1600 | 3200 | 11 | 15 | 37 |
| 500 | 10000-45 | 16000 | 800 | 1600 | 3200 | 11 | 15 | 37 |
| 600 | 16000 | 25000 | 1300 | 2600 | 5000 | 11 | 15 | 37 |

3.3 General

Note

Additional equipment or additional measuring instruments can only be attached or removed under official supervision!

Before you connect additional equipment, make sure that the direction of rotation and the rotation rate of mechanical transmission coincide.

After you have loosened the two locking screws located on both sides of the meter head, you can turn all meter head designs through 350° to reach an optimum position for taking meter readings. To do this, you need an SW 2 hexagon socket wrench.

If work has to be done on the meter head, please make sure that the official seals are not damaged.

3.4 Pulse transmitters

The TRZ 03 und TRZ 03-K K turbine meters provide different sensors which supply volume pulses in a variety of frequency ranges. These pulses can be further processed by volume correctors or remote totalizers, for example.

Note

All pulse transmitters of the TRZ 03 have been approved for custody transfer metering.

The connection options are shown in the following illustration.

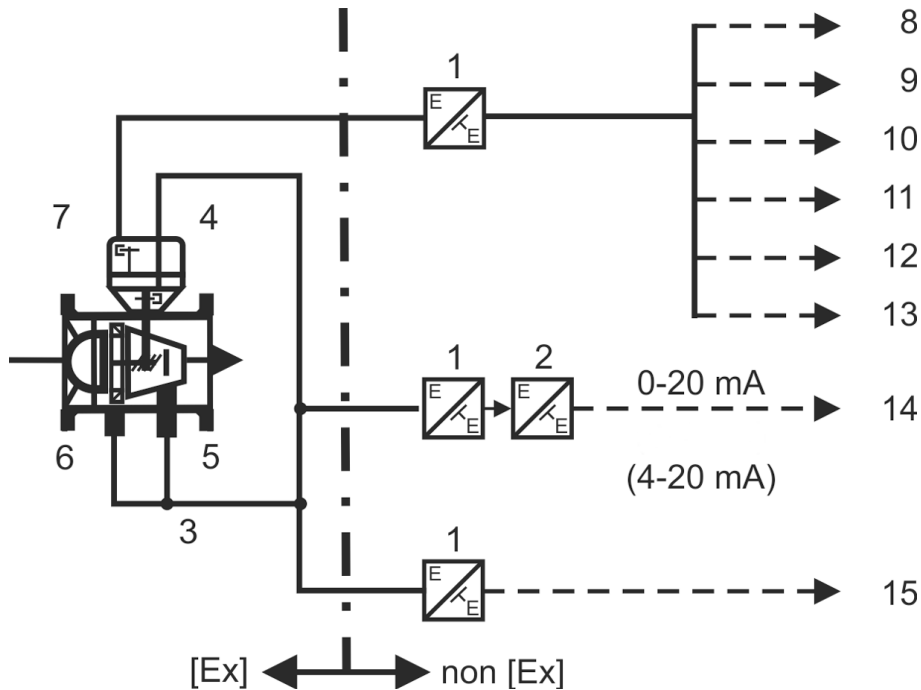



Figure 6: Connection options of the TRZ 03

| No. | Designation | No. | Designation |
|-----|-----------------------------|-----|------------------------|
| 1 | EEx i isolating amplifier | 9 | Volume corrector |
| 2 | Digital-to-analog converter | 10 | Gas flow recorder |
| 3 | Blade monitoring system | 11 | Remote totaliser |
| 4 | HF1 | 12 | Printer |
| 5 | HF2 | 13 | Maximum-value recorder |
| 6 | HF3 | 14 | Min./max. contact |
| 7 | LF | 15 | Volume corrector |
| 8 | Servo-actuator | | |

⚠ Danger



All pulse transmitters are intrinsically safe and must be connected only to intrinsically safe circuits if they are used in areas subject to explosion hazards.

The safety barriers must meet the requirements of the II (2) G Ex ia IIC type of protection!

3.4.1 Connecting additional devices

The meter heads of the RMG TRZ 03 and TRZ 03K turbine meters are fitted with a reed contact as standard. The pulse value corresponds to the rotation rate U_a .

Note

See the indicating plate on the meter head for exact frequency data.

The guide values are given in the tables in *chapter 6 Specifications*. The maximum pulse frequency is 0.3 Hz. Optionally, a slot-type initiator can be installed.

In applications where a higher resolution is required, an additional HF 1 pulse transmitter can be installed. Then the maximum pulse frequency will be of the order of approx. 300 Hz at Q_{max} . The connector pin assignments for the standard design with a reed contact (alternatively, with a slot-type initiator) are shown in the illustration below. Please also note the indicating plate on the meter head.

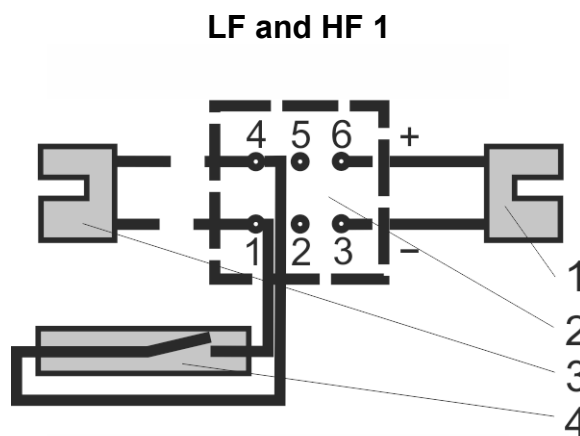

Figure 7: Connector pin assignments for the HF 1 pulse transmitter

| No. | Designation | No. | Designation |
|-----|---|-----|---|
| 1 | Slot initiator HF ($f_{max} = 300$ Hz) (NAMUR) | 3 | Slot initiator (Option, NAMUR) LF ($f_{max} = 0,3$ Hz) |
| 2 | Connector | 4 | Reed-Contact ($f_{max} = 0,3$ Hz) |

3.4.2 Pulse transmitters in measuring element (HF 2 and HF 3)

Note

The higher-frequency flow signals from the HF 2 and HF 3 proximity sensors are used for control purposes and in conjunction with electronic flow computers suitable for custody transfer metering.

41

In the case of the HF 3 pulse transmitter, the pulses are picked off at the turbine wheel, while they are picked off at the reference wheel for the HF 2 pulse transmitter. The two wheels are arranged in such a way that two pulse series of the same frequency are generated which are out of phase by 180°.

Note

The exact frequency is determined during meter proving and is stated on a supplementary data plate on the meter housing.

The guide values are listed in the tables in chapter 6 *Specifications*. The maximum pulse frequency is approx. 2100 Hz at Q_{max} but depends on the meter size.

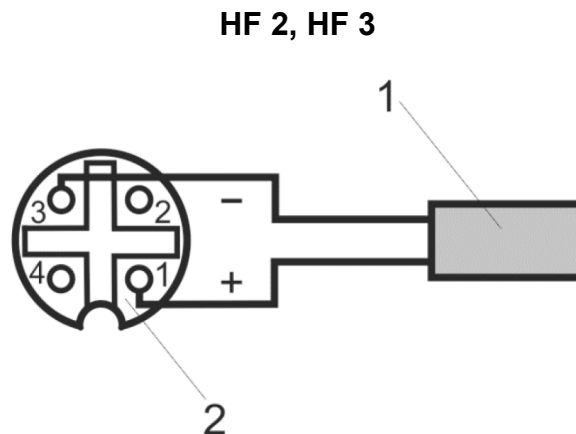

Figure 8: Connector pin assignments for the HF 2/3 pulse transmitter

| No. | Designation | No. | Designation |
|-----|------------------|-----|-------------|
| 1 | Proximity switch | 2 | Connector |

HF 2: reference wheel }
 HF3: turbine wheel } $f_{\max} = 2,1 \text{ kHz (NAMUR)}$

Connections are made by means of multi-pin connectors.

Normally, an LF pulse transmitter is connected to contacts 1 and 4, while a single HF 1 pulse transmitter is connected to contacts 3 and 6. Here the highest number is always (+).

High-frequency pulse transmitters which go with the turbine wheel (HF 2) or the reference wheel (HF 3) are usually connected to contacts 1 and 3 (for older devices 1 and 6).

3.4.3 Connector pin assignments

Connector, 3-pins (HF2/HF3)
 Produced by Binder (series 713)

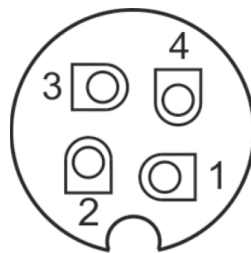

| No. | Designation | No. | Designation |
|-----|-------------|-----|-------------------|
| 1 | + | 3 | - HF signal Namur |
| 2 | Not used | 4 | PE conductor |

Connector, 7-pins
 (meter head "F", HF2/HF3 for older devices),
 Produced by Binder (series 693)

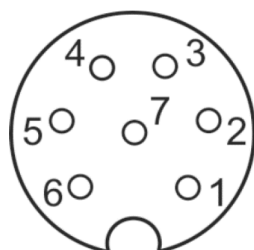

43

| No. | Designation | No. | Designation |
|-----|---------------------------|-----|-------------------------------|
| 1 | - | 2 | - |
| 4 | + LF signal reed or Namur | 5 | + optionally, LF or HF signal |
| 3 | - | 7 | PE (screen) |
| 6 | + HF signal Namur | | |

Connector, 4 pins
 (for older devices)

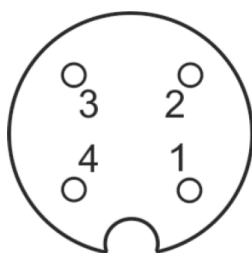

| No. | Designation | No. | Designation |
|-----|---------------------------|-----|-------------|
| 1 | - | 3 | Not used |
| 2 | + LF signal reed or Namur | 4 | PE (screen) |

Connector, 6 pins (for older devices)
produced by Harting

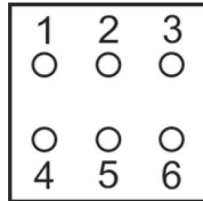

| No. | Designation | No. | Designation |
|-----|---------------------------|-----|-------------------------------|
| 1 | - | 2 | - |
| 4 | + LF signal reed or Namur | 5 | + optionally, LF or HF signal |
| 3 | - | | |
| 6 | + HF signal Namur | | |

Here the cable connector is depicted (connecting part is provided by the customer).

3.5 Specifications of the pulse transmitters

Electrical data:

Reed-contact – Contact as make-contact element



| | |
|------------------------|---------|
| max. switching voltage | 20 V/DC |
| max. switching current | 40 mA |
| max. conduct load | 200 mW |
| f_{max} | 0.3 Hz |

45

LF - slot-type initiator

Inductive proximity switch complying with DIN 19234 (NAMUR)



| | |
|-----------------------------------|--|
| Supply voltage | 7-9 V DC (with internal resistance $R_i = 1\text{ k}\Omega$) |
| current if switch is not operated | $\geq 3\text{ mA}$ |
| current if switch is operated | $\leq 1\text{ mA}$ |
| f_{max} | 0.3 Hz |

HF 1 – slot-type initiator

Inductive proximity switch complying with DIN 19234 (NAMUR)



| | |
|-----------------------------------|--|
| Supply voltage | 7-9 V DC (with internal resistance $R_i = 1\text{ k}\Omega$) |
| current if switch is not operated | $\geq 3\text{ mA}$ |
| current if switch is operated | $\leq 1\text{ mA}$ |
| f_{max} | 300 Hz |

HF 2/HF 3 – Proximity switch

Inductive proximity switch complying with DIN 19234 (NAMUR)



| | |
|-----------------------------------|--|
| Supply voltage | 7-9 V DC (with internal resistance $R_i = 1\text{ k}\Omega$) |
| current if switch is not operated | $\geq 3\text{ mA}$ |
| current if switch is operated | $\leq 1\text{ mA}$ |
| f_{max} | 2100 Hz |

Note

The power rating in terms of the intrinsic safety, refer to the added certificates (s. Annex)

3.6 Temperature measurement

In order to measure the gas temperature, a resistance thermometer can be used in a thermowell in a fitting downstream of the gas meter. It is recommended that a second thermowell, e.g. for a monitoring thermometer, be used. If such thermowells are not provided for in the meter housing, temperature measurement must be performed at a distance of up to 3 x DN or a maximum of 600 mm downstream of the turbine meter.

All turbine meters of types TRZ 03 and TRZ 03-K from the nominal diameter of DN 50 (2") upwards can be fitted with a thermowell for a PT100 resistance thermometer.

Note

The measuring elements of the temperature sensors located outside the gas line must be appropriately insulated against the weather.

In order to achieve optimum thermal conduction, oil as a heat transfer liquid should be filled in the thermowells in any case.

Operating temperatures prevailing at outdoor metering stations in winter or at natural gas metering stations downstream of regulating stations are usually in the range of -5°C to +10°C. By comparison, higher operating temperatures prevail at metering stations located downstream of compressor stations.

3.7 Commissioning

3.7.1 Filling with oil

| Note |
|---|
| <p>When the turbine meters are delivered, the lubricators do not contain any oil.</p> <p>The oil pumps must not be filled with oil until they are at the installation site prior to commissioning!</p> <p>A small bottle of oil is supplied with each gas meter. Then you have to perform an initial lubrication. For this see the detailed lubrication instructions in <i>chapter 4.2 Lubrication</i>.</p> |

47

3.7.2 Commissioning ENCO 08 (optional)

If the optional ENCO 08 encoder is integrated in the meter head, it is **not necessary to parameterise the encoder on site** during commissioning of the TRZ 03. The ENCO 08 is preset to the meter type with its specific data, tested and sealed at the RMG factory by the certified test lab using the user software.

During commissioning on site, only the connection between ENCO 08 and the connected readout device (e.g. flow computer) must be established (see diagram below). The connection for the encoder is located on the back of the meter head. Please refer to section 3.1 for the corresponding pin assignment.

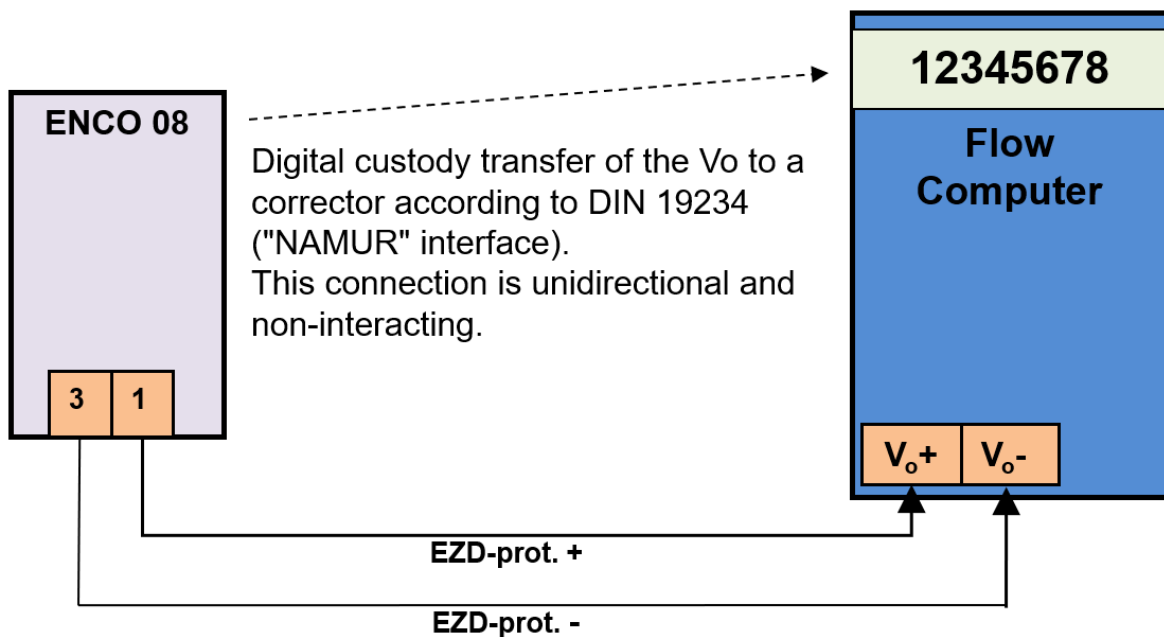

In very few exceptional cases, the factory settings of the encoder may not be compatible with the connected readout device.

For such exceptional cases, RMG Messtechnik offers an ENCO 08 programming module that can be used to reconfigure the parameters.

Please feel free to contact RMG Service for assistance.

Note

Please note that new parameterisation of the encoder may only be carried out by authorised specialist personnel (e.g. RMG service personnel)!

3.7.3 Connecting the gas flow

Warning

Do not fill any downstream pipelines or station sections through the turbine meter. This may speed up the turbine wheel and lead to excessively high loads with resultant damage.

Note

Short-time overload operation of 20% above the maximum flow rate Q_{\max} is permissible. Such load conditions should be avoided, however, since in most cases they cannot be controlled and exceed the officially approved limits for custody transfer metering. Moreover, such overloads reduce the service life of the gas meter.

Warning

The gas flow must be free of foreign particles, dust or liquids. Otherwise it is recommended that filters or separators be installed.

⚠ Danger

When commissioning this device, make sure that all cables are correctly connected and routed.

The housing must be completely closed.

When connecting and commissioning the pulse generators and the encoder, follow the specifications of the corresponding standards

- **DIN EN 60079-0 and**
- **DIN EN 60079-14**

4 Operation

4.1 Influences on the error of measurement due to operation

4.1.1 Intermittent operation

Warning

Rapid changes of the gas flow should be avoided, since the turbine wheel can follow these changes only with a certain delay due to its inertia. In this way, errors of measurement occur, in particular, if the gas flow is shut off.

Since in this case the turbine wheel slows down after the flow has stopped, a gas volume is measured which is always higher than that which has actually flowed through the gas meter.

In the supplement to PTB Guideline G 13, an instrument is stipulated which records the flow during the slow-down time of the turbine wheel for intermittent operation (i.e. if the gas flow is permanently switched on and shut off). If control signals of a shut-off valve are available, this volume can be recorded by a suitable data logger (if there is a TAZ 9 installed in an older station, this RMG device records the slow-down volume for custody transfer metering purposes with the TRZ 03).

4.1.2 Influence of pulsations

The gas flow must be free of shocks or pulsations. A gas metering station can be affected by flow pulsations, however, if the following equipment has been installed upstream or downstream in the system:

- reciprocating piston compressors
- rotary displacement meters
- gas pressure regulators lacking steadiness of operation
- pipes where no gas flows (siphons)

Volume flow pulsation is the decisive quantity for evaluating the performance of gas meters under the influence of pulsations. Volume flow pulsation is physically always associated with pressure variations.

The following relation is established in a first approximation:

$$\hat{Q}_{rel} \approx \hat{p}_{rel} \frac{DN^2}{Q} K$$

With:

\hat{Q}_{rel} : is the relative volume flow pulsation (peak-to-peak)

\bar{Q} : is the mean volumetric flow

\hat{p}_{rel} : is the relative pressure pulsation (peak-to-peak)

DN: is the nominal diameter of the gas meter

K: is a constant depending on standard density, velocity of sound, compressibility, pressure at base conditions, temperature, and station-specific parameters.

With this relation, it is possible to estimate volume flow pulsation on the basis of pressure pulsation, which can be measured more easily. Direct measurement of volume flow pulsation is preferable, however, since the results are more reliable. The crucial factor is the pulsation at the location of measurement.

4.1.3 Consequences

Note

In the case of pulsating flow, the turbine meter shows a measured value which is too high.

Due to the pulse applied by the flow on the impeller which increases quadratically with the flow velocity, the resultant rotational speed is higher than the mean value of the flow velocity. The influence with high gas density is less but increases with a high mass moment of inertia (heavy impeller) or fast-running wheels.

The influence is less with high gas density but increases with high mass moment of inertia (heavy impeller) or fast-running wheels.

Warning

Furthermore, high pulsation amplitudes may result in premature wear of shaft bearings due to in-creased load.

4.1.4 Limiting values

Frequency ranges

- It is generally unlikely that measured values will be distorted in the frequency range above 100 Hz.
- In practice, it is hardly possible to initiate any significant flow variations at such frequencies.
- Disturbances are to be expected most frequently in the frequency range between 0.1 Hz and 100 Hz, since with typical station dimensions, the gas column can be expected to produce resonances. Flow variations with a high relative amplitude may occur.
- In the frequency range below 0.1 Hz, there is a quasi-steady flow which will not cause any distortion with the gas meters.

Pulsation amplitudes

Studies have shown that no disturbances are to be expected in the case of relative flow pulsations below 5% (peak-to-peak) and relative pressure pulsations of less than 0.1% to 0.5% (peak-to-peak).

These data should be regarded as approximate values depending on the flow rate and pulsation frequency involved.

4.2 Lubrication

4.2.1 Lubricator

For lubrication, either an oil gun or a permanently fitted oil pressure pump is used. The various designs are given in the tables below.

| | Type of oilpump | Container volume | Delivered quantity |
|-----------|-----------------------|---------------------|-------------------------------|
| KO | Pushbutton pump | 8 cm ³ | 0.114 cm ³ /stroke |
| GO | Lever pump | 150 cm ³ | 1.5 cm ³ /stroke |
| DS | Permanent lubrication | -- | -- |

| | TRZ 03-K | | TRZ 03 | |
|-----|-----------------------|-------------------------------------|-----------------------|-------------------------------------|
| | Pressure classes | | Pressure classes | |
| DN | PN 10, 16 ANSI 150 | PN 25, 40, 64, 100 ANSI 300, 600 | PN 10, 16 ANSI 150 | PN 25, 40, 64, 100 ANSI 300, 600 |
| 50 | DS (KO) ¹⁾ | KO | DS (KO) ¹⁾ | KO |
| 80 | DS (KO) ¹⁾ | KO | DS (KO) ¹⁾ | KO |
| 100 | DS (KO) ¹⁾ | KO | DS (KO) | KO |
| 150 | DS (KO) ¹⁾ | KO | DS (KO) | KO |
| 200 | KO | | KO | |
| 250 | KO | GO | GO | |
| 300 | GO | | GO | |
| 400 | GO | | GO | |
| 500 | GO | | GO | |
| 600 | GO | | GO | |

¹⁾ Types in brackets are options

4.2.2 Specification for lubricating oils

Note

For lubrication purposes, we recommend that you use only Shell Tellus S2 MA 10 or another lubricating oil with 2 to 4°E at 25°C in order to avoid damage to the shaft bearings. You can order your supply of lubricating oil from us in 1-liter containers under

Ref. No. 82.11.148.00 1 litre containment.

Shelf life of oil:

The shelf life depends on the operating conditions (e.g. UV light, humidity, etc.). In principle the oil suffers no quality loss during the first 3-4 years.

4.2.3 Initial lubrication

When the turbine meters are delivered, the lubricators do not contain any oil. The oil pumps must not be filled with oil until they are at the installation site prior to commissioning. A small bottle of oil is supplied with each gas meter.

Note

For the initial lubrication more pump strokes are necessary than for the relubrications because first the oil pipes have to be filled with oil.

| Pump | DN 50 – DN 200 | DN 250 – DN 600 |
|-------------------------|----------------|-----------------|
| KO (pushbutton pump) | 40 strokes | 45 strokes |
| GO (lever pump) | - | 10 strokes |

4.2.4 Relubrication

Note

The relubrication intervals are stated on an indicating plate on the meter housing. See also *chapter 4.2.5 Lubrication procedure*.

Example:

Re - Lubrication

At 3 month intervals, 2 strokes.
 Lubricant: 2 - 4°E with 25°C
 The containervolume of 0,15 litre
 is for 3 years sufficient.
 Supplementary info see operating instruction.

Note

In the case of poor operating conditions, such as condensate forming because of water or hydrocarbon, or dust-laden gas, or service temperatures above 50°C, we recommend that lubrication will be performed at shorter intervals, even daily under extreme conditions (permanent building of condensate).
 If the gas meter is operated under the above-mentioned conditions, it is likely that its service life will be reduced. If you have questions to the relubrication in such cases please contact RMG.

4.2.5 Lubrication procedure

Proceed as follows to fill and lubricate the pumps:

Pushbotton pump (KO)

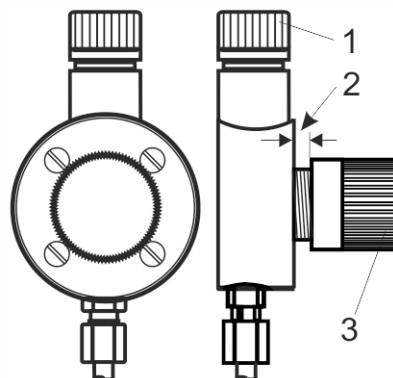

| No. | Designation | No. | Designation |
|-----|-------------|-----|---------------|
| 1 | Cover | 3 | Knurled cover |
| 2 | Gap | | |

To fill with oil

- Unscrew cover.
- Fill with oil.
- Screw on cover again.

To lubricate up to 50 bar

- Unscrew knurled cover
- Press pushbutton, which is now visible, once for each stroke (delivered quantity: 0,114 cm³/stroke)
- Screw on knurled cover again. Make sure you stop screwing as soon as you can feel a resistance and leave a gap of approx. 7 mm.

To lubricate meters over 50 bar:

- Loosen the knurled cover
- Screw on the pushbutton tightly, once for each stroke (delivered quantity: 0,114 cm³/stroke)
- Screw on knurled cover again. Make sure you stop screwing as soon as you can feel a resistance and leave a gap of approx. 7 mm.

| | | |
|-----------------------------|-------------------|-------------------------|
| Initial lubrication: | 40 strokes | (up to DN 200) |
| | 45 strokes | (from DN 250) |
| Relubrication: | 6 strokes | (every 3 months) |

Lever pump (GO)

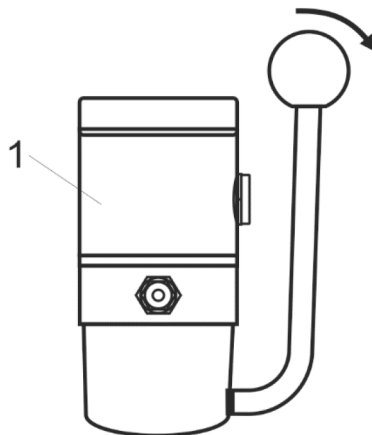

| No. | Designation | No. | Designation |
|-----|-------------|-----|-------------|
| 1 | Cover | | |

Lever pump (GO) To fill with oil

- Pull off cover upwards (when using a lever pump with transparent container, unscrew cover).
- Fill in oil.
- Push on cover again tightly (or screw it on again).

To lubricate

- Move lever once for each stroke as far as it will go. (delivered quantity: 1,5 cm³/stroke)

| | |
|-----------------------------|-----------------------|
| Initial lubrication: | 10 strokes |
| Relubrication: | every 3 months |
| up to DN 400: | 2 strokes |
| From DN 500 | 3 strokes |

4.2.6 Maintenance instructions

RMG turbine meters are maintenance-free except that they require lubrication at regular intervals. Since all gas meters fitted with oil pumps are shipped with an empty oil storage tank, it is absolutely essential to fill the storage tank of the oil pump with oil and perform the initial lubrication before the gas meter is put into service (see section “Lubrication”).

The operator should nevertheless check the turbine meter at regular intervals. In this connection, please refer also to DVGW code of practice G 495. (Gas pressure regulators for monitoring and servicing large-scale gas metering systems)

The gas meter should be checked for accuracy approximately every two years depending on whether it is possible or necessary to perform such checks. This can be done as follows:

- In the station itself by connecting two gas meters in series.
- In an officially acknowledged testing laboratory for gas measuring instruments.
- In the factory.

(chapter 1.7 *Validity of meter proving*)

5 Labelling

All important data which are necessary for operating the gas meter are stated on the plates which are affixed to the meter housing, totalizer or pulse transmitters.

58

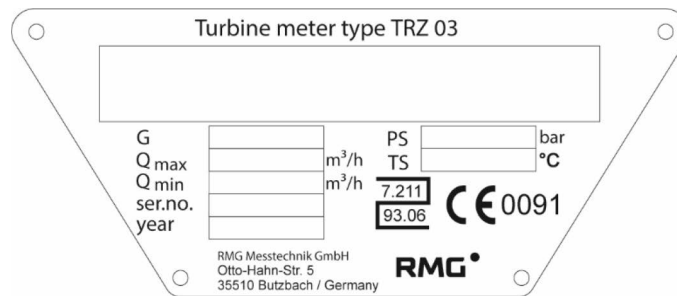

Main data plate of the TRZ 03 turbine meter with type “F” meter head (PTB approval)

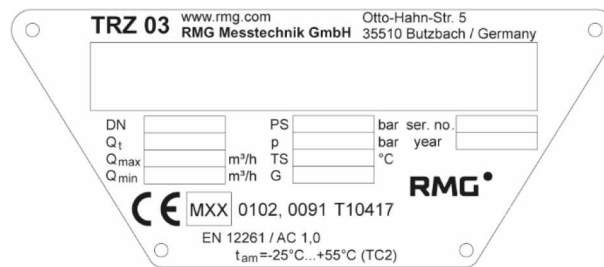

Main data plate of the TRZ 03 turbine meter with type “F” meter head (MID approval)

- TS: Permitted temperature range for meter housing (PED)
- PS: Maximum permitted pressure for meter housing (PED)
- t_{am}: Permitted temperature range for custody transfer metering (MID) “F”

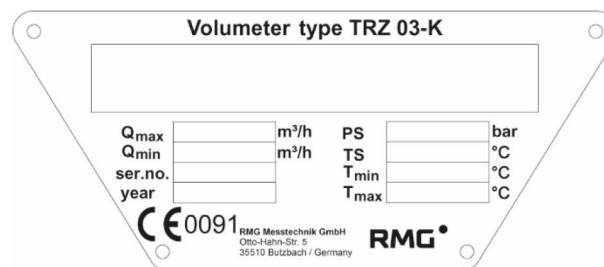

Main data plate of the volumeter with type “F” meter head

Pulse Outputs

For use only with intrinsically safe and approved equipment



| | | | | | |
|----------------|------|-------------------|--|-----------|--|
| I ₁ | 1••4 | 1m ³ ± | | imp | |
| | | | | LF-Reed | |
| I ₂ | 2••5 | 1m ³ ± | | | |
| I ₃ | 3••6 | 1m ³ ± | | imp | |
| | | | | HF1-Namur | |

Built-in pulse transmitters, type “F” meter heads.
 For use only with intrinsically safe and approved equipment.

Re - Lubrication

At 3 month intervals, 2 strokes.
 Lubricant: 2 - 4°E with 25°C
 The containervolume of 0,15 litre
 is for 3 years sufficient.
 Supplementary info see operating instruction.

Indicating plate for relubrication of the main bearings
 At 3-month intervals, 2 strokes. Lubricant: 2 - 4°E with 25°C. The containervolume of 0,15 litre is for 3 years sufficient. Supplementary info see operating instruction.

Re - Lubrication

At 3 month intervals, 6 strokes.
 Lubricant: 2-4°E with 25°C
 The containervolume of 8 ml
 is for 2½ years sufficient.
 Supplementary info see operating instruction.

Indicating plate for relubrication of the main bearings
 At 3-month intervals, 6 strokes. Lubricant: 2-4°E with 25°C. The containervolume of 8 ml is for 2½ years sufficient. Supplementary info see operating instruction.



60
Arrow indicating the direction of flow



Indication of the reference pressure tap

6 Specifications

6.1 Measuring ranges / Dimensions / Pressure classes TRZ03 (PTB)

61

| DN mm in | Size | Measuring range $Q_{\min}-Q_{\max} / \text{m}^3/\text{h}$ | | U _a m ³ | Press. classes/Approx. weight | | | | Dimensions mm | | | |
|----------------|------------------|--|--------------------|----------------------------------|-------------------------------|---------|------|-----|------------------|-----|-----|-----|
| | | 1:10/1:20 | 1:30 | | PN | kg | ANSI | kg | L | H | C | B |
| 50 2" | G 40 | 13-65* ¹ | - | 0,1 | 10/16 | 13 | 150 | 13 | | | | |
| | G 65 | 10-100* ² | - | 0,1 | 25/40 | 21 | 300 | 13 | 150 | 210 | 60 | 160 |
| | | | | | 100 | 21 | 600 | 21 | | | | |
| 80 3" | G 100 | 16-160 | - | 1 | 10/16 | 20 | 150 | 20 | | | | |
| | G 160 | 12.5-250* ² | - | 1 | 25/40 | 25 | 300 | 25 | 240 | 230 | 96 | 180 |
| | G 250 | 20-400* ² | - | 1 | 100 | 34 | 600 | 36 | | | | |
| 100 4" | G 160 | 12.5-250 | - | 1 | 10/16 | 25 | 150 | 30 | | 240 | | |
| | G 250 | 20-400 | - | 1 | 25/40 | 32 | 300 | 35 | 300 | 260 | 120 | 200 |
| | G 400 | 32-650 | 20-650 | 1 | 100 | 45 | 600 | 55 | | 270 | | |
| 150 6" | G 400 | 32-650 | - | 1 | 10/16 | 50 | 150 | 50 | | 265 | | |
| | G 650 | 50-1000 | 32-1000 | 1 | 25/40 | 60 | 300 | 65 | 450 | 265 | 180 | 220 |
| | G 1000 | 80-1600 | 50-1600 | 10 | 100 | 70/90 | 600 | 100 | | 285 | | |
| 200 8" | G 1000 G 1600 | 80-1600 125-2500 | 50-1600 80-2500 | 10 10 | 10/16 | 75 | 150 | 100 | | 300 | | |
| | | | | | 25/40 | 95 | 300 | 120 | 600 | 320 | 240 | 260 |
| | | | | | 64/100 | 150/160 | 600 | 160 | | 320 | | |
| 250 10" | G 1000 | 80-1600 | - | 10 | 10/16 | 100/110 | 150 | 110 | | | | |
| | G 1600 | 125-2500 | 80-2500 | 10 | 25/40 | 135/150 | 300 | 160 | 750 | 330 | 300 | 390 |
| | G 2500 | 200-4000 | 130-4000 | 10 | 64/100 | 180/225 | 600 | 260 | | | | |
| 300 12" | G 2500 | 200-4000 | 130-4000 | 10 | 10/16 | 138/150 | 150 | 155 | | | | |
| | G 4000 | 320-6500 | 200-6500 | 10 | 25/40 | 225/265 | 300 | 230 | 900 | 360 | 360 | 410 |
| | G 4000 -45 | 320-6500 | 200-6500 | 10 | | | | | | | | |
| 400 16" | G 4000 | 320- 6500 | 200-6500 | 10 | 10/16 | 200/290 | 150 | 350 | | | | |
| | G 6500 | 500-10000 | 320-10000 | 10 | 25/40 | 350/440 | 300 | 460 | 1200 | 400 | 480 | 450 |
| | G 6500 -45 | 500-10000 | 320-10000 | 10 | | | | | | | | |

| | DN mm in | Size | Measuring range | | Ua m ³ | Press. classes/Approx. weight | | | | Dimensions mm | | | |
|------------|--------------------|-----------------------------|--|------------|----------------------|-------------------------------|----------|------|------|------------------|-----|-----|-----|
| | | | Q _{min} -Q _{max} / m ³ /h | | | PN | kg | ANSI | kg | L | H | C | B |
| | | | 1:10/1:20 | 1:30 | | | | | | | | | |
| 62 | 500 20" | G 6500 | 500-10000 | 320-10000 | 10 | 10/16 | 560/610 | 150 | 620 | | | | |
| | | G 10000 | 800-16000 | 500-16000 | 100 | 25/40 | 640/700 | 300 | 650 | 1500 | 450 | 600 | 490 |
| | | G 10000 -45 | 800-16000 | 500-16000 | 100 | 100 | 830/1060 | 600 | 1075 | | | | |
| 600 24" | G 10000 G 16000 | 800-16000 1250- 25000 | 500-16000 800-25000 | 100 100 | 10/16 | 900/940 | 150 | 950 | | | | | |
| | | | | | 25/40 | 980/1075 | 300 | 1000 | 1800 | 500 | 720 | 540 | |
| | | 100 | 1230/1570 | 600 | 1600 | | | | | | | | |

*1 (Measuring range 1:5)

DN 500 and DN 600 only ANSI600RF
(other flanges only on request)

*2 For DN50 / DN80 a measuring rang of 1:20 is only achievable for p ≥ 3 barg

PN pressure classes complying with DIN EN 1092,
ANSI pressure classes complying with B16.5

The turbine meters of all pressure
classes can be fitted with a thermowell
to accommodate a resistance
thermometer.

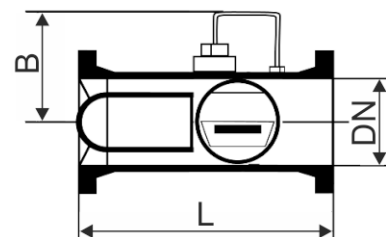
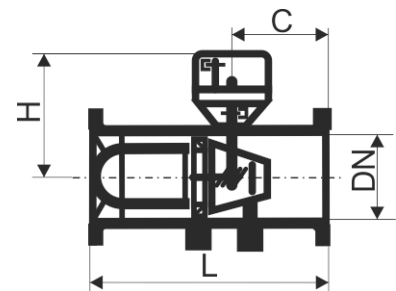

6.2 Measuring ranges / Dimensions / Pressure classes TRZ03-K

| Nominal dia DN | | Measuring range $Q_{min}-Q_{max}$ m ³ /h | U _a m ³ | Pressure classes | L m | H* m | Weight t App. kg | Housing design |
|----------------|------|---|----------------------------------|---|--------|---------|------------------------|--------------------|
| mm | Zoll | | | | | | | |
| 50 | 2" | 5-100 | 0,1 | PN 10, 16, 25, 40 ANSI 150, 300, 600 | 150 | 212 | 10 | Flanged-end design |
| 80 | 3" | 8-160 13-250 (20-400) | 1 | PN 10, 16, 25 ANSI 150 | 120 | 245 | 14 | |
| 100 | 4" | 20-400 (20-650) | 1 | PN 10, 16, 25 ANSI 150 | 150 | 255 | 25 | |
| 150 | 6" | 20-650 20-1000 (100-1600) | 1 | PN 10, 16, 25 ANSI 150 | 175 | 285 | 40 | |
| 200 | 8" | 100-1600 160-2500 | 10 | PN 10, 16, 25 ANSI 150 | 200 | 305 | 60 | |
| 250 | 10" | 160-2500 (250-4000) | 10 | PN 10, 16, 25 ANSI 150 | 300 | 300 | 70 | |
| 300 | 12" | 250-4000 (400-6500) | 10 | PN 10, 16, 25 ANSI 150 | 300 | 365 | 100 | |
| 400 | 16" | 400-6500 (650-10000) | 10 | PN 10, 16, 25 ANSI 150 | 600 | 390 | 280 | |
| 500 | 20" | 650-10000 (1000-16000) | 10 | PN 10, 16, 25 ANSI 150 | 750 | 445 | 500 | |
| | | | | PN 40, 64, 100 ANSI 300, 600 | 750 | 515 | 650 | |
| 600 | 24" | 1000-16000 (1600-25000) | 100 | PN 10, 16, 25 ANSI 150 | 900 | 465 | 650 | |
| | | | | PN 40, 64, 100 ANSI 300, 600 | 900 | 580 | 850 | |

DN500 and DN600 only on request.

The details about pressure range, weights and dimensions must be agreed upon when ordering.

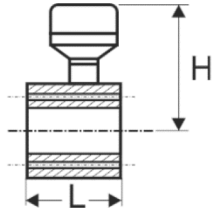
| Nominal dia DN | Measuring range | | U _a m ³ | Pressure classes | L mm | H* mm | Weight App. kg | Housing design |
|-------------------|--------------------|---------------------------------|----------------------------------|---------------------|---------|----------|-------------------|---|
| | mm | in | | | | | | |
| 50 | 2" | 5-100 | 0,1 | ANSI 300, 600 | 80 | 212 | 15 | Monoflange design  |
| 80 | 3" | 8-160 13-250 (20-400) | 1 | ANSI 300, 600 | 120 | 245 | 35 | |
| 100 | 4" | 20-400 (20-650) | 1 | ANSI 300, 600 | 150 | 255 | 50 | |
| 150 | 6" | 20-650 20-1000 (100-1600) | 1 | ANSI 300, 600 | 175 | 285 | 100 | |
| 200 | 8" | 100-1600 160-2500 | 10 | ANSI 300, 600 | 200 | 305 | 130 | |
| 250 | 10" | 160-2500 (250-4000) | 10 | ANSI 300, 600 | 250 | 300 | 200 | |

DN 300 - 1000 on request

* Dimension "H" with built-in totalizer

(with attached totalizer: dimension "H" + 28 mm)

6.3 Q_{min} depending on the operating pressure in natural gas

Values for custody transfer metering, according to MID approval

| DN [m m] | G-value | Q_{max} [m ³ /h] | Flow [m ³ /h] at $p_{min}=1$ bar ^[1] | | Q_{min} [m ³ /h] depending on operating pressure p_{min} [bar(g)] | | | | | | | | | | | | | |
|----------|----------|--------------------------------|--|------------------|--|-----------|------------|------------|------------|-----------|------------|------------|------------|-----------|------------|-----------|------------|-----------|
| | | | | | MR ^[2] 1:20 | | MR 1:30 | | MR 1:50 | | MR 1:80 | | MR 1:100 | | MR 1:120 | | MR 1:160 | |
| | | | | | Q_t | Q_{min} | Q_{mi_n} | p_{mi_n} | Q_{mi_n} | p_{min} | Q_{mi_n} | p_{mi_n} | Q_{mi_n} | p_{min} | Q_{mi_n} | p_{min} | Q_{mi_n} | p_{min} |
| 50 | 65 | 100 | 20 | 5 ^[3] | | | | | | | | | | | | | | |
| 80 | 100 | 160 | 32 | 8 ^[3] | 5 | 15 | 3,2 | 50 | | | | | | | | | | |
| | 160 | 250 | 50 | 12,5 | 8 | 3 | 5 | 10 | 3,2 | 50 | | | | | | | | |
| 100 | 250 | 400 | 80 | 20 | 13 | 3 | 8 | 10 | 5 | 25 | | | | | | | | |
| | 160 | 250 | 50 | 12,5 | 8 | 3 | 5 | 25 | | | | | | | | | | |
| | 250 | 400 | 80 | 20 | 13 | 3 | 8 | 10 | 5 | 25 | | | | | | | | |
| 150 | 400 | 650 | 130 | 32 | 20 | 3 | 13 | 4 | 8 | 10 | 6,5 | 15 | 5 | 25 | | | | |
| | 650 | 1000 | 200 | 50 | 32 | 3 | 20 | 4 | 13 | 10 | 10 | 15 | 8 | 25 | | | | |
| 200 | 1000 | 1600 | 320 | 80 | 50 | 3 | 32 | 4 | 20 | 10 | 16 | 15 | 13 | 25 | 10 | 40 | | |
| | 1600 | 2500 | 500 | 125 | 80 | 3 | 50 | 4 | 32 | 10 | 25 | 15 | 20 | 25 | 16 | 40 | | |
| 250 | 1000 | 1600 | 320 | 80 | 50 | 3 | 32 | 10 | 20 | 25 | 16 | 40 | | | | | | |
| | 1600 | 2500 | 500 | 125 | 80 | 3 | 50 | 4 | 32 | 10 | 25 | 25 | 20 | 40 | 16 | 60 | | |
| 300 | 2500 | 4000 | 800 | 200 | 130 | 3 | 80 | 4 | 50 | 10 | 40 | 25 | 35 | 40 | 25 | 60 | | |
| | 4000 | 6500 | 1300 | 320 | 220 | 3 | 130 | 10 | 80 | 25 | 65 | 40 | 55 | 60 | 40 | 80 | | |
| | 4000-45 | 6500 | 1300 | 320 | 220 | 3 | 130 | 10 | 80 | 25 | 65 | 40 | 55 | 60 | 40 | 80 | | |
| 400 | 4000 | 6500 | 1300 | 320 | 220 | 3 | 130 | 10 | 80 | 25 | 65 | 40 | 55 | 60 | 40 | 80 | | |
| | 6500 | 10000 | 2000 | 500 | 335 | 3 | 200 | 10 | 125 | 25 | 100 | 40 | 85 | 60 | 63 | 80 | | |
| 500 | 6500-45 | 10000 | 2000 | 500 | 335 | 3 | 200 | 10 | 125 | 25 | 100 | 40 | 85 | 60 | 63 | 80 | | |
| | 6500 | 10000 | 2000 | 500 | 335 | 3 | 200 | 10 | 125 | 25 | 100 | 40 | 85 | 60 | 63 | 80 | | |
| | 10000 | 16000 | 3200 | 800 | 535 | 3 | 320 | 10 | 200 | 25 | 160 | 40 | 135 | 60 | 100 | 80 | | |
| 600 | 10000-45 | 16000 | 3200 | 800 | 535 | 3 | 320 | 10 | 200 | 25 | 160 | 40 | 135 | 60 | 100 | 80 | | |
| | 10000 | 16000 | 3200 | 800 | 535 | 3 | 320 | 10 | 200 | 25 | 160 | 40 | 135 | 60 | 100 | 80 | | |
| 600 | 16000 | 25000 | 5000 | 1250 | 835 | 3 | 500 | 10 | 315 | 25 | 250 | 40 | 210 | 60 | 160 | 80 | | |

[1] $p = 1$ bar; means atmospheric pressure

[2] MR = Measuring range = Q_{max} / Q_{min}

[3] MR: 1:20; for $p \geq 3$ bar(g)

To get the Q_{\min} , the high pressure value for defined values of the operating pressure and for other gas types you can calculate it using the formula in *chapter 1.8.1 Extension of the measuring range* or you can contact the RMG service.

6.4 Values for secondary metering for meters without MID approval

| G | Q_{\max} m ³ /h | $Q_{\min LP1}$ m ³ /h | $Q_{\min, HP}$ – natural gas m ³ /h | | | | | | | | |
|-------|---------------------------------|-------------------------------------|---|-----|-----|-----|-----|-----|-----|-----|-----|
| | | | Operating pressure in bara | | | | | | | | |
| | | | 5 | 10 | 15 | 20 | 30 | 40 | 50 | 60 | 100 |
| 65 | 100 | 10 ²⁾ | 5 | 4 | 3 | 3 | 2 | 2 | 2 | 2 | 1 |
| 100 | 160 | 16 ²⁾ | 7 | 6 | 4 | 4 | 3 | 3 | 2 | 2 | 2 |
| 160 | 250 | 13 | 7 | 6 | 4 | 4 | 3 | 3 | 2 | 2 | 2 |
| 250 | 400 | 20 | 11 | 8 | 6 | 6 | 5 | 4 | 4 | 3 | 2 |
| 400 | 650 | 32 | 18 | 13 | 10 | 9 | 7 | 6 | 6 | 5 | 4 |
| 650 | 1000 | 50 | 28 | 20 | 16 | 14 | 11 | 10 | 9 | 8 | 6 |
| 1000 | 1600 | 80 | 44 | 31 | 26 | 22 | 18 | 16 | 14 | 13 | 10 |
| 1600 | 2500 | 130 | 72 | 51 | 42 | 36 | 29 | 26 | 23 | 21 | 16 |
| 2500 | 4000 | 200 | 111 | 78 | 64 | 55 | 45 | 39 | 35 | 32 | 25 |
| 4000 | 6500 | 320 | 178 | 126 | 103 | 89 | 72 | 63 | 56 | 51 | 40 |
| 6500 | 10000 | 500 | 277 | 196 | 160 | 139 | 113 | 98 | 88 | 80 | 62 |
| 10000 | 16000 | 800 | 444 | 314 | 256 | 222 | 181 | 157 | 140 | 128 | 99 |
| 16000 | 25000 | 1300 | 721 | 510 | 416 | 361 | 294 | 255 | 228 | 208 | 161 |

1) LP-standard measuring ranges 1:20 and 1:30 (on request)

2) Measuring range 1:10

To get the $Q_{\min, HP}$ value for defined values of the operating pressure and for other gas types you can calculate it using the formula in *chapter 1.8.1 Extension of the measuring range* or contact RMG.

6.5 Overview of the materials used



| Designation | Material |
|----------------------------|-------------------------------------|
| Meter housing | GGG40, cast steel or welded steel * |
| Flow straightener | Delrin, aluminium or steel |
| Turbine wheel | Delrin or aluminium |
| Measuring element housing | Aluminium |
| Measuring element bearings | Aluminium and/or stainless steel |
| Ball bearings | Stainless steel |
| Shafts | Stainless steel |
| Gearing | Stainless steel or plastic |
| Magnetic coupling | Stainless steel |
| Meter head | Aluminium |
| Totalizer | Plastic |
| Meter board | Aluminium, die-cast zinc or brass |

* The meter housing DN50 and DN80 can be made of round steel (solid material) for the lower pressure classes PN10, PN16, PN25, PN40 and ANSI150. Please contact RMG if necessary.

Annex

A. Certificates for LF-/HF-sensors and encoder

The transmitters used in the turbine meters have their own ATEX approval and are marked according to the following table.

| Pulse transmitter type | Type of sensor | EC-Type examination Certificate according to directive 2014/34/EU | Manufacturer | Annex |
|------------------------------------|---------------------------------------|---|---|---------|
| LF- pulse transmitter (LF) | Reed contact: 59140-010 | Not required (passive component) | Hamlin IP22 4NX Diss, Norfolk England | – |
| HF-pulse transmitter (HF1) | Inductive proximity switch: N7S20A |  BVS 08 ATEX E026 IECEX BVS 09.0016 II 1 G Ex ia IIC T* Ga | IFM electronic D-45127 Essen Germany | Page 73 |
| HF-pulse transmitter (HF2 and HF3) | Inductive proximity switch: NF503A |  PTB 01 ATEX 2192 IECEX PTB 08.0058 II 1 G Ex ia IIC T5 Ga | IFM electronic D-45127 Essen Germany | Page 78 |
| ENCO | Rotary counter: ENCO-08 R2 |  BVS 25 ATEX E 047 X II 2G Ex ib IIC T4 Gb | RMG Mess- technik GmbH D-35510 Butz- bach Deutschland | Page 81 |

* see the certificate below

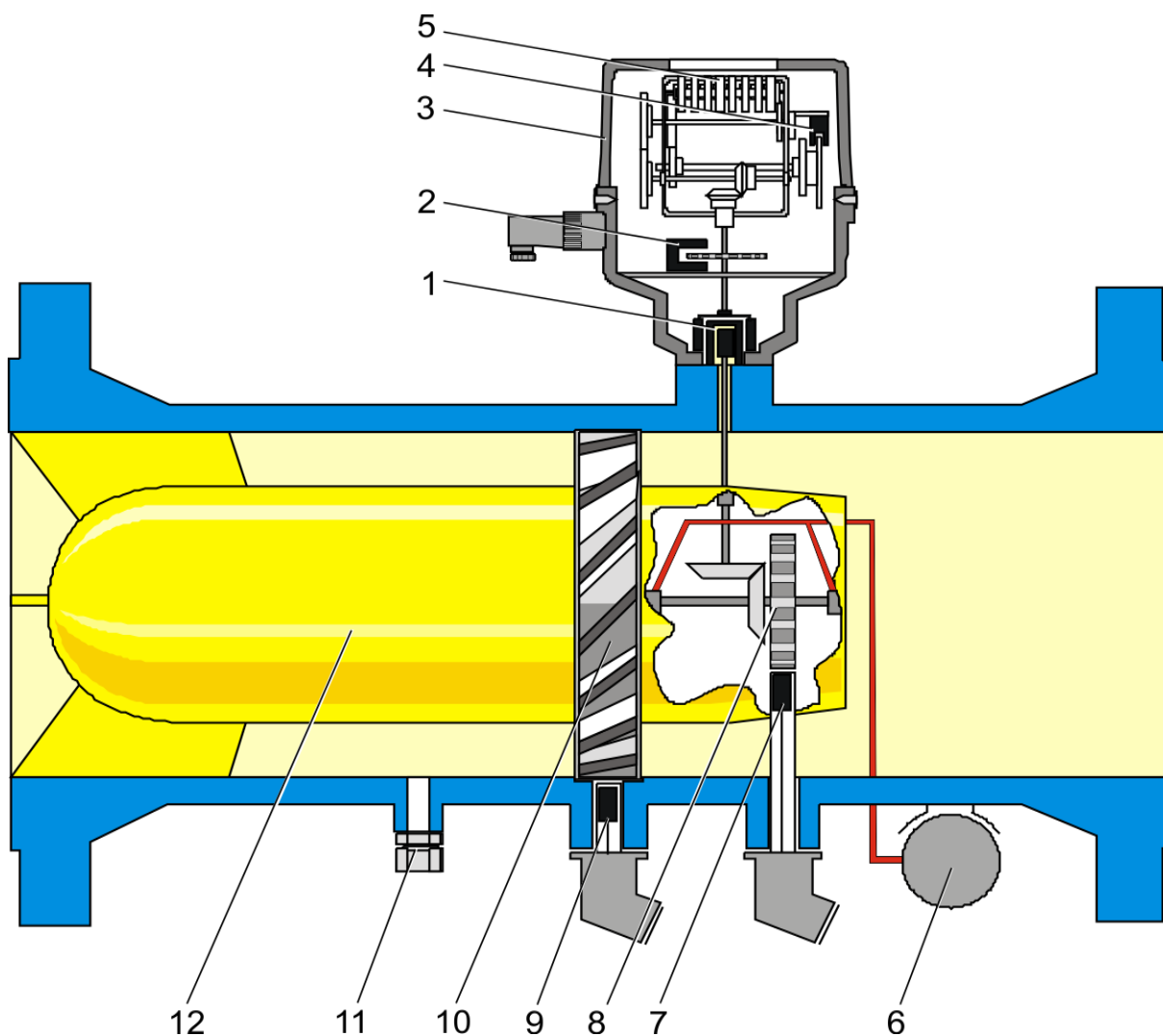

Figure 9: Sectional drawing of a turbine meter

| No. | Designation | No. | Designation |
|-----|--------------------------------------|-----|--------------------------------------|
| 1 | Magnetic coupling | 7 | High-frequency pulse transmitter HF2 |
| 2 | High-frequency pulse transmitter HF1 | 8 | Reference wheel |
| 3 | Meter head type „F“ | 9 | High-frequency pulse transmitter HF3 |
| 4 | Low-frequency pulse transmitter LF | 10 | Turbine wheel |
| 5 | Digital index | 11 | p _r connection |
| 6 | Oil pump | 12 | Flow straightener |

B. Certificates

- EU-Declaration of Conformity TRZ 03 (Annex B.1)
- EU-Declaration of Conformity TRZ 03-K (Annex B.2)
- EC-Type Examination Certificate for LF- and HF-Sensors (Annex B.3)
- EC-Type Examination Certificate (1. Supplement) for LF- and HF-Sensors (Annex B.4)
- EG-Baumusterprüfbescheinigung für NF- und HF-Sensoren (Annex B.5)
- EU-Type Examination Certificate (Translation) for Rotary counter type ENCO-08 R2 (Annex B.6)
- EU-type examination certificate (Annex B.7)
- Production Quality Assurance Notification (Annex B.8)
- Certificate on Pressure Equipment Directive 2014/68/EU Module D (Annex B.9)
- Certificate on the approval of a quality system (Annex B.10)
- EU-type examination certificate – production type Module B according to directive 2014/68/EU TRZ 03 (Annex B.11)
- EU-type examination certificate – production type Module B according to directive 2014/68/EU TRZ 03-K (Annex B.12)

Note

EU Declaration of Conformity

The listed declarations of conformity reflect the status on the date of issue of the operating instructions. The latest version of the EU Declarations of Conformity is available on our website www.rmg.com.

B.1. EU-Declaration of Conformity TRZ 03

EU-Declaration of Conformity
EU-Konformitätserklärung



We **RMG Messtechnik GmbH**
 Wir Otto – Hahn – Straße 5
 35510 Butzbach
 Germany

Declare under our sole responsibility that the product is in conformity with the directives. Product is labeled according to the listed directives and standards and in accordance with the Type-Examination.
 Erklären in alleiniger Verantwortung, dass das Produkt konform ist mit den Anforderungen der Richtlinien. Das entsprechend gekennzeichnete Produkt ist nach den aufgeführten Richtlinien und Normen hergestellt und stimmt mit dem Baumuster überein.

Product **Turbine Meter TRZ 03**
 Produkt **Turbinenradgaszähler TRZ 03**

| Harmonisation Legislations <i>Harmonisierungsrechtsvorschriften</i> | ATEX | PED | MID |
|---|--|--|--|
| EU- Directives <i>EU-Richtlinie</i> | 2014/34/EU | 2014/68/EU | 2014/32/EU |
| Marking <i>Kenntzeichen</i> | II 2G Ex ib T6 / T4 | --- | --- |
| Normative Documents <i>Normative Dokumente</i> | EN 60079-0: 2018 EN 60079-11: 2012 | AD 2000 – Merkblätter | DIN EN 12261:2024 |
| EU Type-Examination issued by <i>EU-Baumusterprüfung ausgestellt durch</i> | Ex Gutachten für Reed Schalter ----- PTB 01 ATEX 2192 (HF2-D & HF3-D) ----- BVS 08 ATEX E 026 (HF1) ----- BVS 25 ATEX E 047 X (ENCO-08 R2) | Modul B ISG-22-22-1095_Rev. 05 TÜV Hessen Germany | Modul B T10417 NMI Netherland |
| Approval of a Quality System by <i>Anerkennung eines Qualitätssicherungssystems durch</i> | Modul D BVS 20 ATEX ZQS/E139 Notified Body: 0158 DEKRA Testing and Certification GmbH Germany | Modul D 73 202 2839 Notified Body: 0091 TÜV Hessen Germany | Modul D DE-M-AQ-PTB023 Notified Body: 0102 PTB Germany |

The object of the declaration described above is in conformity with Directive 2011/65/EU of the European Parliament and of the Council of 8 June 2011 on the restriction of the use of certain hazardous substances in electrical and electronic equipment.
 Der oben beschriebene Gegenstand der Erklärung erfüllt die Vorschriften der Richtlinie 2011/65/EU des Europäischen Parlaments und des Rates vom 8. Juni 2011 zur Beschränkung der Verwendung bestimmter gefährlicher Stoffe in Elektro- und Elektronikgeräten.

RMG Messtechnik GmbH
 Butzbach, den 02.04.2026

Thorsten Dietz
 (CEO)

Sascha Körner
 (Technical Manager)

B.2. EU-Declaration of Conformity TRZ 03-K

EU-Declaration of Conformity EU-Konformitätserklärung



We **RMG Messtechnik GmbH**
 Wir Otto – Hahn – Straße 5
 35510 Butzbach
 Germany

Declare under our sole responsibility that the product is in conformity with the directives. Product is labeled according to the listed directives and standards and in accordance with the Type-Examination.

Erklären in alleiniger Verantwortung, dass das Produkt konform ist mit den Anforderungen der Richtlinien. Das entsprechend gekennzeichnete Produkt ist nach den aufgeführten Richtlinien und Normen hergestellt und stimmt mit dem Baumuster überein.

Product **Turbine Meter TRZ 03-K**
 Produkt **Turbinenradgaszähler TRZ 03-K**

| Harmonisation Legislations <i>Harmonisierungsrechtsvorschriften</i> | ATEX | PED |
|---|---|--|
| EU- Directives <i>EU-Richtlinie</i> | 2014/34/EU | 2014/68/EU |
| Marking <i>Kennzeichen</i> |  II 2G Ex ib T6 / T4 | --- |
| Normative Documents <i>Normative Dokumente</i> | EN 60079-0: 2012 EN 60079-11: 2012 | AD 2000 – Merkblätter |
| EU Type-Examination issued by <i>EU-Baumusterprüfung ausgestellt durch</i> | Ex-Gutachten für Reed Schalter PTB 01 ATEX 2192 (HF2-D & HF3-D) BVS 08 ATEX E 026 (HF1) BVS 25 ATEX E 047 X (ENCO-08 R2) | Modul B ISG-22-22-1081 Rev 04 TÜV Hessen Germany |
| Approval of a Quality System by <i>Anerkennung eines Qualitätssicherungssystems durch</i> | Modul D BVS 23 ATEX ZQS/E139 Notified Body: 0158 DEKRA Testing and Certification GmbH | Modul D 73 202 2839 Notified Body: 0091 TÜV Hessen Germany |



The object of the declaration described above is in conformity with Directive 2011/65/EU of the European Parliament and of the Council of 8 June 2011 on the restriction of the use of certain hazardous substances in electrical and electronic equipment.

Der oben beschriebene Gegenstand der Erklärung erfüllt die Vorschriften der Richtlinie 2011/65/EU des Europäischen Parlaments und des Rates vom 8. Juni 2011 zur Beschränkung der Verwendung bestimmter gefährlicher Stoffe in Elektro- und Elektronikgeräten.

RMG Messtechnik GmbH
 Butzbach, den 21.04.2026

 Thorsten Dietz
 (CEO)

 Sascha Körner
 (Technical Manager)

B.3. EC-Type Examination Certificate for LF- and HF-Sensors



Translation

73

- (1) **EC-Type Examination Certificate**
- (2) **- Directive 94/9/EC -**
Equipment and protective systems intended for use
in potentially explosive atmospheres
- (3) **BVS 08 ATEX E 026**
- (4) **Equipment:** Proximity sensor type I7*2***-N***
- (5) **Manufacturer:** ifm electronic gmbh
- (6) **Address:** 45127 Essen, Germany
- (7) The design and construction of this equipment and any acceptable variation there to are specified in the appendix to this type examination certificate.
- (8) The certification body of DEKRA EXAM GmbH, notified body no. 0158 in accordance with Article 9 of the Directive 94/9/EC of the European Parliament and the Council of 23 March 1994, certifies that this equipment has been found to comply with the Essential Health and Safety Requirements relating to the design and construction of equipment and protective systems intended for use in potentially explosive atmospheres, given in Annex II to the Directive.
The examination and test results are recorded in the test and assessment report BVS-PP 08.2029 EG.
- (9) The Essential Health and Safety Requirements are assured by compliance with:

| | |
|-------------------|---------------------------|
| EN 60079-0:2006 | General requirements |
| EN 60079-11:2007 | Intrinsic safety 'i' |
| IEC 60079-26:2006 | Group II Zone 0 Apparatus |
| EN 61241-0:2006 | General requirements |
| EN 61241-11:2004 | Intrinsic safety 'iD' |
- (10) If the sign "X" is placed after the certificate number, it indicates that the equipment is subject to special conditions for safe use specified in the appendix to this certificate.
- (11) This EC-Type Examination Certificate relates only to the design, examination and tests of the specified equipment in accordance to Directive 94/9/EC.
Further requirements of the Directive apply to the manufacturing process and supply of this equipment. These are not covered by this certificate.
- (12) The marking of the equipment shall include the following:

II 1G Ga Ex ia IIC T4 / T5 / T6
II 1D Ex iaD 20 T125 °C / 100 °C / 85 °C

DEKRA EXAM GmbH
Bochum, dated 31. March 2008

Signed: **Dr. Jockers**

Signed: **Dr. Eickhoff**

Certification body

Special services unit

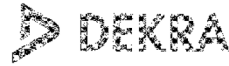

(13) Appendix to

(14) **EC-Type Examination Certificate****BVS 08 ATEX E 026**(15) 15.1 Subject and type

Proximity sensor type I7*2***-N****

Instead of the *** in the complete denomination letters and numerals will be inserted which characterize modifications.

15.2 Description

The proximity sensor is used in explosive atmospheres for detection of metallic parts.

15.3 Parameters

One of the following combinations with resulting temperature values:

| Electrical parameters | Voltage U_i [V] | | 15 | | 16 | | 16 | | 16 | | |
|---|---|-----|-----|-----|-----|----|-----|-----|-----|-----|-----|
| | Current I_i [mA] | | 50 | | 25 | | 25 | | 52 | | |
| | Power P_i [mW] | | 120 | | 34 | | 64 | | 169 | | |
| Temperature class | T6 | T4 | T6 | T5 | T4 | T6 | T5 | T4 | T6 | T5 | T4 |
| max. surface temperature [°C] for DUST | 85 | 125 | 85 | 100 | 125 | 85 | 100 | 125 | 85 | 100 | 125 |
| Type | Max. ambient temperature (-40 °C up to) | | | | | | | | | | |
| I7S2***-N**** | 60 | 100 | 72 | 87 | 100 | 70 | 85 | 100 | 55 | 70 | 100 |
| I7R2***-N**** | 60 | 100 | 75 | 790 | 100 | 70 | 85 | 100 | 55 | 70 | 100 |
| I7R2***-NI*** | 70 | 100 | 75 | 90 | 100 | 75 | 90 | 100 | 70 | 85 | 100 |

Maximum internal capacitance C_i and maximum internal inductance L_i in accordance with the following table:

| Type | L_i [μ H] | C_i [nF] |
|----------------|------------------|------------|
| I7S2002-N | 120 | 150 |
| I7S2015-N | 150 | 150 |
| I7R2010-N**** | 100 | 150 |
| I7R2015-N**** | 100 | 150 |
| I7R2010-NL**** | 90 | 90 |
| I7R2015-NL**** | 65 | 90 |

Ambient temperature range

 T_a

-40 °C up to (see table)

(16) Test and assessment report

BVS PP 08.2029 EG as of 31.03.2008

(17) Special conditions for safe use

None



We confirm the correctness of the translation from the German original.
In the case of arbitration only the German wording shall be valid and binding.

44809 Bochum, 31. March 2008
BVS-Schu/Wa A 20080199

DEKRA EXAM GmbH

Certification body

Special services unit



B.4. EC-Type Examination Certificate (1. Supplement) for LF- and HF-Sensors

76

Translation

(1) 1. Supplement to the EC-Type Examination Certificate

(2) Equipment and protective systems intended for use in potentially explosive atmospheres - Directive 94/9/EC Supplement accordant with Annex III number 6

(3) No. of EC-Type Examination Certificate: **BVS 08 ATEX E 026**

(4) Equipment: **Proximity sensor type I7*2***-N*****

(5) Manufacturer: **ifm electronic gmbh**

(6) Address: **45128 Essen, Germany**
former **45127 Essen, Germany**

(7) The design and construction of this equipment and any acceptable variation thereto are specified in the appendix to this supplement.

(8) The certification body of DEKRA EXAM GmbH, notified body no. 0158 in accordance with Article 9 of the Directive 94/9/EC of the European Parliament and the Council of 23 March 1994, certifies that this equipment has been found to comply with the Essential Health and Safety Requirements relating to the design and construction of equipment and protective systems intended for use in potentially explosive atmospheres, given in Annex II to the Directive. The examination and test results are recorded in the test and assessment report BVS PP 08.2029 EG.

(9) The Essential Health and Safety Requirements are assured by compliance with:
IEC 60079-0:2011 General requirements
IEC 60079-11:2011 Intrinsic safety 'i'
EN 60079-26:2007 Equipment with equipment protection level (EPL) Ga

(10) If the sign "X" is placed after the certificate number, it indicates that the equipment is subject to special conditions for safe use specified in the appendix to this certificate.

(11) This supplement to the EC-Type Examination Certificate relates only to the design, examination and tests of the specified equipment in accordance to Directive 94/9/EC. Further requirements of the Directive apply to the manufacturing process and supply of this equipment. These are not covered by this certificate.

(12) The marking of the equipment shall include the following:

Ex II 1G Ex ia IIC T⁺ Ga
II 1D Ex ia IIC T⁺ C Da

DEKRA EXAM GmbH
Bochum, dated 19. April 2012

Signed: Dr. Eickhoff
Certification body

Signed: Dr. Wittler
Special services unit

Page 1 of 2 to BVS 08 ATEX E 026 / N1
This certificate may only be reproduced in its entirety and without change.
DEKRA EXAM GmbH Dinnendahlstrasse 9 44809 Bochum Phone +49.234.3696-105 Fax +49.234.3696-110 zs-exam@dekra.com



- (13) Appendix to
- (14) **1. Supplement to the EC-Type Examination Certificate**
BVS 08 ATEX E 029
- (15) 15.1 Subject and type
Proximity sensor type I7*2***-N****

15.2 Description

The sensor can be modified according to the descriptive documents as mentioned in the pertinent test and assessment report and the conformity of the sensor with the standards IEC 60079-0:2011, IEC 60079-11:2011 and EN 60079-26:2007 has been assessed

15.3 Parameters

Not changed

- (16) Test and assessment report
BVS PP 08.2029 EG as of 19.04.2012
- (17) Special conditions for safe use
None

We confirm the correctness of the translation from the German original.
In the case of arbitration only the German wording shall be valid and binding.

DEKRA EXAM GmbH
44809 Bochum, 19. April 2012
BVS-Schu/Sp A 20120312

[Signature]

Certification body

[Signature]

Special services unit

B.5. EU-Type Examination Certificate for LF- and HF-Sensors



(1) **EU-TYPE EXAMINATION CERTIFICATE**
(Translation)

- (2) Equipment or Protective Systems Intended for Use in Potentially Explosive Atmospheres - **Directive 2014/34/EU**
- (3) EU-Type Examination Certificate Number:
PTB 01 ATEX 2192 **Issue: 1**
- (4) Product: Inductive proximity switches, types N95000, NF503A and NF504A
- (5) Manufacturer: ifm electronic gmbh
- (6) Address: Friedrichstraße 1, 45128 Essen, Germany
- (7) This product and any acceptable variation thereto is specified in the schedule to this certificate and the documents therein referred to.
- (8) The Physikalisch-Technische Bundesanstalt, notified body No. 0102 in accordance with Article 17 of the Directive 2014/34/EU of the European Parliament and of the Council, dated 26 February 2014, certifies that this product has been found to comply with the Essential Health and Safety Requirements relating to the design and construction of products intended for use in potentially explosive atmospheres, given in Annex II to the Directive.
The examination and test results are recorded in the confidential Test Report PTB Ex 19-28127.
- (9) Compliance with the Essential Health and Safety Requirements has been assured by compliance with:
EN 60079-0:2012 + A11:2013 **EN 60079-11:2012**
- (10) If the sign "X" is placed after the certificate number, it indicates that the product is subject to the Specific Conditions of Use specified in the schedule to this certificate.
- (11) This EU-Type Examination Certificate relates only to the design and construction of the specified product in accordance to the Directive 2014/34/EU. Further requirements of the Directive apply to the manufacturing process and supply of this product. These are not covered by this certificate.
- (12) The marking of the product shall include the following:



II 1 G Ex ia IIC T6 Ga or
II 1 G Ex ia IIC T5 Ga or
II 1 G Ex ia IIC T4 Ga

Konformitätsbewertungsstelle - Sektor Explosionsschutz
On behalf of PTB:

Braunschweig, March 26, 2019

Dr.-Ing. F. Lienesch
Direktor und Professor



ZSEx001e c

sheet 1/3

EU-Type Examination Certificates without signature and official stamp shall not be valid. The certificates may be circulated only without alteration. Extracts or alterations are subject to approval by the Physikalisch-Technische Bundesanstalt. In case of dispute, the German text shall prevail.

Physikalisch-Technische Bundesanstalt • Bundesallee 100 • 38116 Braunschweig • GERMANY



Physikalisch-Technische Bundesanstalt
Braunschweig und Berlin
Nationales Metrologieinstitut



(13)

SCHEDULE

(14) **EU-Type Examination Certificate Number PTB 01 ATEX 2192, Issue: 1**

(15) Description of Product

The inductive proximity switches of types N95000, NF503A and NF504A are designed for use in potentially explosive atmospheres.

For relationship between the marking and the permissible range of the ambient temperature, reference is made to the following table:

| Inductive proximity switches, types N95000, NF503A and NF504A | |
|---|--|
| Marking | Permissible range of the ambient temperature T_{amb} |
| II 1 G Ex ia IIC T6 Ga | -25 °C ... +55 °C |
| II 1 G Ex ia IIC T5 Ga | -25 °C ... +60 °C |
| II 1 G Ex ia IIC T4 Ga | -25 °C ... +70 °C |

Electrical data

Supply and signal circuit type of protection Intrinsic Safety Ex ia IIC
(BN (+) and BU (-)) for connection to certified intrinsically safe circuits only

Maximum values:

- $U_i = 15 \text{ V}$
- $I_i = 50 \text{ mA}$
- $P_i = 120 \text{ mW}$
- $L_i = 100 \text{ } \mu\text{H}$
- $C_i = 90 \text{ nF}$

Changes with respect to previous editions

- Modification of the electronic circuitry and the PCB-layout
- Introduction of the new variant NF504A
- Adaption to the current state of standards
- Revision of the type labels
- Revision of the operating instructions manual

sheet 2/3

EU-Type Examination Certificates without signature and official stamp shall not be valid. The certificates may be circulated only without alteration. Extracts or alterations are subject to approval by the Physikalisch-Technische Bundesanstalt. In case of dispute, the German text shall prevail.

Physikalisch-Technische Bundesanstalt • Bundesallee 100 • 38116 Braunschweig • GERMANY



Physikalisch-Technische Bundesanstalt
Braunschweig und Berlin
 Nationales Metrologieinstitut



SCHEDULE TO EU-TYPE EXAMINATION CERTIFICATE PTB 01 ATEX 2192, Issue: 1

(16) Test Report PTB Ex 19-28127

(17) Specific conditions of use
 none

(18) Essential health and safety requirements
 Met by compliance with the aforementioned standards.

According to Article 41 of Directive 2014/34/EU, EC-type examination certificates which have been issued according to Directive 94/9/EC prior to the date of coming into force of Directive 2014/34/EU (April 20, 2016) may be considered as if they were issued already in compliance with Directive 2014/34/EU. By permission of the European Commission supplements to such EC-type examination certificates and new issues of such certificates may continue to hold the original certificate number issued before April 20, 2016.

Konformitätsbewertungsstelle, Sektor Explosionsschutz
 On behalf of PTB

Braunschweig, March 26, 2019

Dr.-Ing. F. Lienesch
 Direktor und Professor



sheet 3/3

EU-Type Examination Certificates without signature and official stamp shall not be valid. The certificates may be circulated only without alteration. Extracts or alterations are subject to approval by the Physikalisch-Technische Bundesanstalt. In case of dispute, the German text shall prevail.

Physikalisch-Technische Bundesanstalt • Bundesallee 100 • 38116 Braunschweig • GERMANY

B.6. EU-Type Examination Certificate (Translation) for Rotary counter type ENCO-08 R2



Translation

1 EU-Type Examination Certificate

2 **Directive 2014/34/EU of the European Parliament and of the Council of 26 February 2014**

3 EU-Type Examination Certificate Number: **BVS 25 ATEX E 047 X** Issue: **00**

4 Equipment: **Rotary counter type ENCO-08 R2**

5 Manufacturer: **RMG Messtechnik GmbH**

6 Address: **Otto-Hahn-Straße 5, 35510 Butzbach, Germany**

7 This product and any acceptable variations thereto are specified in the appendix to this certificate and the documents referred to therein.

8 DEKRA Testing and Certification GmbH, Notified Body number 0158, in accordance with Article 17 of Directive 2014/34/EU of the European Parliament and of the Council, dated 26 February 2014, certifies that this product has been found to comply with the Essential Health and Safety Requirements relating to the design and construction of products intended for use in potentially explosive atmospheres given in Annex II to the Directive.
The examination and test results are recorded in the confidential Report No. BVS PP 25.2094 EU.

9 Compliance with the Essential Health and Safety Requirements has been assured by compliance with:

| | |
|--|--|
| <p>EN IEC 60079-0:2018 IEC 60079-11:2023</p> | <p>General requirements Intrinsic Safety "I"</p> |
|--|--|

Where additional criteria beyond those given here have been used, they are listed at item 18 in the Schedule.

10 If the sign "X" is placed after the certificate number, it indicates that the product is subject to the "Specific Conditions of Use" listed under item 17 of this certificate.

11 This EU-Type Examination Certificate relates only to the technical design of the specified product in accordance with the Directive 2014/34/EU. Further requirements of the Directive apply to the manufacturing process and supply of this product. These are not covered by this certificate.

12 The marking of the product shall include the following:

 **II 2G Ex ib IIC T4 Gb**

DEKRA Testing and Certification GmbH
 Bochum, 2025-09-26

Signed: Oliver Brumm

 Managing Director

Page 1 of 3 of BVS 25 ATEX E 047 X Issue 00 – Jobnumber A 20240877 / 343583100
 This certificate may only be reproduced in its entirety and without any change.

DEKRA Testing and Certification GmbH, Handwerkstr. 15, 70565 Stuttgart, Germany
 Certification body: Dinnendahlstr. 9, 44809 Bochum, Germany
 Phone +49.234.3696-400, Fax +49.234.3696-401, e-mail DTC-Certification-body@dekra.com



81



13 Appendix

14 EU-Type Examination Certificate

BVS 25 ATEX E 047 X issue 00

15 Product description

15.1 Subject and type

Rotary counter type ENCO-08 R2

15.2 Description

The Rotary Counter type ENCO-08 R2 is designed for installation inside mechanical totalizer turbine meters / totalizer rotary meters and comes with a metallic enclosure containing a printed circuit board and an electromechanical pulse probe.

The mechanical explosion protection of the output shaft is not part of this EU type examination certificate. The intrinsically safe supply and signal circuit (standardized 2-wire NAMUR switching level interface) is connected to a plug connector.

Listing of all components used referring to older standards: Not applicable

15.3 Parameters

15.3.1 Intrinsically safe supply- and signal-circuit

| Parameter | Temperature Class | |
|--------------------------------|-------------------|---|
| | T4 | |
| Voltage | U_i | DC 13.5 V |
| Current | I_i | 20 mA |
| Power | P_i | 68 mW |
| Effective internal capacitance | C_i | negligible |
| Effective internal inductance | L_i | negligible |
| Ambient temperature range | T_a | $-40\text{ °C} \leq T_a \leq +60\text{ °C}$ |

15.3.2 Maximum revolution rate: 500 r.p.m.

16 Report Number



BVS PP 25.2094 EU, as of 2025-09-26

17 Specific Conditions of Use

17.1 The Rotary Counter type ENCO-08 R2 shall be mounted inside a housing providing degree of protection IP20 according to EN 60529 as a minimum.

17.2 The ENCO 08 cable according to drawing no. 060609.4 must be used to connect the intrinsically safe supply and signal circuits.

B.7. EU-type examination certificate for TRZ 03

| | | | |
|--|--|--|---|
|  | | <h2>EU-type examination Certificate</h2> | |
| | | Number T10417 revision 9 Project number 2661457 Page 1 of 1 | |
| Issued by | NMI Certin B.V., designated and notified by the Netherlands to perform tasks with respect to conformity assessment procedures mentioned in article 17 of Directive 2014/32/EU, after having established that the Measuring instrument meets the applicable requirements of Directive 2014/32/EU, to: | | |
| Manufacturer | RMG Messtechnik GmbH Otto-Hahn-Strasse 5 D-35510, Butzbach Germany | | |
| Measuring instrument | A Turbine Gas Meter Type : TRZ03 and TRZ04 Manufacturer's mark or name : RMG Messtechnik Destined for the measurement of : Gas volume Accuracy class : Class 1,0 Environment classes : M1 / E2 Temperature range : -25 °C / +55 °C | | |
| | Further properties are described in the annexes: – Description T10417 revision 9; – Documentation folder T10417-8. | | |
| Valid until | 19 March 2032 | | |
| Remark | This revision replaces the earlier versions, except for its documentation folder. | | |
| Issuing Authority | NMI Certin B.V., Notified Body number 0122 19 March 2022 | | |
| | Certification Board | | |
| NMI Certin B.V. Thijsseweg 11 2629 JA Delft The Netherlands T +31 88 636 2332 certin@nmi.nl www.nmi.nl | This document is issued under the provision that no liability is accepted and that the manufacturer shall indemnify third-party liability. The designation of NMI Certin B.V. as Notified Body can be verified at http:// ec.europa.eu/growth/tools-databases/nando/ | | Reproduction of the complete document only is permitted. This document is digitally signed and sealed. The digital signature can be verified in the blue ribbon at the top of the electronic version of this certificate. |
| | | |  |

B.8. Production Quality Assurance Notification



Production Quality Assurance Notification

2 Equipment and Protective Systems intended for use in potentially explosive atmospheres
Directive 2014/34/EU
Annex IV - Module D: Conformity to type based on quality assurance of the production process
Annex VII - Module E: Conformity to type based on product quality assurance

3 Notification number: **BVS 23 ATEX ZQS/E139**

4 Product category: Equipment and components
equipment-group II, categories 1G, 2G: Manufacturing and sale of Volume Meters, Electronic Correctors and Gas Analyzers, Electrical equipment and devices



ONE STEP AHEAD

5 Manufacturer: RMG Messtechnik GmbH

6 Address: Otto-Hahn-Strasse 5, 35510 Butzbach, Germany

Site(s) of manufacture: RMG Messtechnik GmbH, Otto-Hahn-Strasse 5, 35510 Butzbach, Germany
RMG Messtechnik GmbH, Heinrich-Lanz-Strasse 9, 67259 Beindersheim, Germany

7 The certification body of DEKRA Testing and Certification GmbH, Notified Body No 0158 in accordance with Article 17 of the Council Directive 2014/34/EU of 26 February 2014 notifies that the manufacturer has a production quality system, which complies with Annex IV of the Directive. This quality system in compliance with Annex IV of the Directive also meets the requirements of Annex VII. In the updated annex all products covered by this notification and their type examination certificate numbers are listed.

8 This notification is based on audit report ZQS/E139/23 issued 2024-08-23. Results of periodical re-assessments of the quality system are a part of this notification.

9 This notification is valid from 2023-10-28 until 2025-10-28 and can be withdrawn if the manufacturer does not satisfy the production quality assurance surveillance according to Annex IV and VII.

10 According to Article 16 (3) of the Directive 2014/34/EU the CE marking shall be followed by the identification number 0158 of DEKRA Testing and Certification GmbH as notified body involved in the production control phase.

DEKRA Testing and Certification GmbH
Bochum, 2024-08-23



Managing Director

This is a translation from the German original.
In the case of arbitration only the German wording shall be valid and binding.

Page 1 of 1 - Jobnumber 040092100
This notification may only be reproduced in its entirety and without any change.
DEKRA Testing and Certification GmbH, Handwerkerstr. 15, 70565 Stuttgart, Germany
Certification body: Dinnendahlstr. 3, 44809 Bochum, Germany
Phone +49.204.9396-400, Fax +49.204.9396-401, e-mail DTC-Certification-body@dekra.com

B.9. Certificate on Pressure Equipment Directive 2014/68/EU Module D

86

CERTIFICATE



for a management system as per

Pressure Equipment Directive 2014/68/EU
Module D

Evidence of conformity has been furnished.

Certificate registration No.:
73 202 2839

Certificate valid from:
2024-07-16 **to:** 2027-07-15



RMG Messtechnik GmbH
Otto-Hahn-Straße 5
35510 Butzbach / Germany

Scope:
Production of gas meters and
associated items of equipment



Dr. Ponick

Dr. M. Ponick
Head of Certification body
Release: Darmstadt 2024-05-24
Certification Body of TÜV Hessen



Page 1 of 1
This certification confirms the introduction and maintenance of the Management system specified above and is monitored regularly. The current validity is verifiable at www.prof.cert.de. Original certificates contain a glued hologram.
TÜV Technische Überwachung Hessen GmbH, Robert-Bosch-Strasse 16, 64293 Darmstadt, Germany Phone +49 6151/600331 Rev-G3-2401 Translation of German original

B.10. Certificate on the approval of a quality system



Physikalisch-Technische Bundesanstalt
Nationales Metrologieinstitut

KBS

Konformitätsbewertungsstelle

87



Zertifikat
Certificate

über die Anerkennung eines Qualitätssicherungssystems
on the approval of a quality system

Ausgestellt für: RMG Messtechnik GmbH
Issued to: Otto-Hahn-Str. 5
35510 Butzbach

gemäß: Mess- und Eichverordnung vom 11. Dezember 2014 (MessEV)
In accordance with: Measures and Verification Ordinance dated 11 December 2014 (MessEV)
in Verbindung mit
in connection with

- Richtlinie **2014/32/EU** vom 26. Februar 2014 (MID)
- Directive **2014/32/EU** of 26 February 2014 (MID)

Messgröße lt. MessEV § 1: Volumen
Measurand acc. to Measures and Verification Ordinance, section 1: Volume
Sonstige Messgrößen bei der Lieferung von strömenden Flüssigkeiten oder strömenden Gasen
Other measurands in the supply of flowing liquids or flowing gases

Nr. des Zertifikats: DE-M-AQ-PTB023, Revision 6
Certificate No.:

Gültig bis: 08.02.2027
Valid until:

Anzahl der Seiten: 6
Number of pages:

Geschäftszeichen: PTB-9.22-4123084
Reference No.:

Nr. der Stelle: 0102
Body No.:

Im Auftrag
On behalf of PTB

Markus Umer

Braunschweig, 23.05.2025

Siegel
Seal



R3-027579

B.11. EU-type examination certificate – production type Module B according to directive 2014/68/EU TRZ 03

TÜV Technische Überwachung Hessen GmbH

Industrie Service
Hans – Böckler – Straße 4
Telefon: 06403 / 9008 – 0

35440 Linden
Fax: 06403 / 9008 - 20



ZERTIFIKAT

(EU-BAUMUSTERPRÜFBESCHEINIGUNG FÜR BAUMUSTER)
(EU-type examination certificate – production type)

EU-Baumusterprüfung (Modul B für Baumuster) nach Richtlinie 2014/68/EU
EU-type examination (Module B - production type) according to directive 2014/68/EU

Zertifikat – Nr.: ISG-22-22-1095_Rev. 05

Name und Anschrift
des Herstellers: **RMG Messtechnik GmbH
Otto-Hahn-Strasse 5
D-35510 Butzbach**

Name and postal address
of the manufacturer:

Hiermit wird bestätigt, dass das unten genannte Baumuster die Anforderungen der Richtlinie 2014/68/EU erfüllt.

We herewith certify that the type mentioned below meets the requirements of the directive 2014/68/EU.

Prüfbericht – Nr.: **siehe Beiblätter zu/ see attached sheet: ISG-22-22-1095_Rev. 05**
Test report No.:

Bezeichnung: **Turbinradgaszähler TRZ03 / TRZ04**
Designation: **DN80, DN100, DN150, DN200, DN250, DN300, DN400, DN500**

Geltungsbereich: **Turbinradgaszähler TRZ03 / TRZ04**
Scope of examination: **siehe Beiblätter zu/ see attached sheet to: ISG-22-22-1095_Rev. 05**

Prüfobjekt: **druckhalt. Ausrüstungsteil (pressure accessory)**
Inspection item:

Kategorie: **I - IV**
Category:

Fertigungsstätte: **Otto-Hahn-Str. 5, D-35510 Butzbach**
Manufacturing plant:

Gültig bis: **siehe Beiblätter zu/ see attached sheets to: ISG-22-22-1095_Rev. 05**
Valid:

- Bemerkungen / Hinweise: **○ Das Zertifikat ISG-22-22-1095_Rev. 04 vom 02.06.2025 ist hiermit ersetzt und verliert seine Gültigkeit! / The certificate ISG-22-22-1095_Rev. 04 dated 02.06.2025 is hereby replaced and loses their validity!**
- Die zulässigen Einsatztemperaturen und die zugelassenen Materialien der Turbinenradgaszähler sind der Entwurfsprüfung des Baumuster zu entnehmen. / The permitted operating temperatures and the permitted materials of the turbine wheel gas meter can be found in the design examination of the EU-types.**

Anlagen: **siehe Beiblatt zu/ see attached sheet to:**
documents: **ISG-22-22-1095_Rev. 05**

TÜV Technische Überwachung Hessen GmbH
Notified body, No.: 0091

Linden, 03.09.2025
place, date

Zertifizierer:

Holger Dietrich Digital signiert von
Holger Dietrich
Datum: 03.09.2025

Dietrich

S. Droß

Umseitige Hinweise beachten / see hints overleaf

ISG_22_22-1095_REV_05_RMG_B+B_TRZ 03+TRZ04.Docx



Subject to technical modification

For further information
please visit our website:

www.rmg.com

or contact your local sales support office
to learn more about the RMG products.

RMG Messtechnik GmbH
Otto-Hahn-Straße 5
35510 Butzbach, Deutschland
Tel: +49 (0) 6033 897-0
Fax: +49 (0) 6033 897-130
Email: service@rmg.com
Internet: www.rmg.com

TRZ 03-MAN | V12-04.2026 | 00.10.131.02-EN