



Operating Manual

Turbine Meter TME 400-VM (.-VMF)

Status: June 30th, 2025
Version: 12
Firmware: 1.12 / 11.12

Manufacturer Contact our customer service department for technical information.

Address	RMG Messtechnik GmbH Otto-Hahn-Straße 5 D-35510 Butzbach (Germany)
Main office	+49 6033 897 – 0
Service-Hotline	+49 6033 897 – 897
Fax	+49 6033 897 – 130
Email	service@rmg.com



You can register your product on our website at <https://www.rmg.com/en/help/device-registration>. By this you are helping us to improve our support

Translation of the original document

The manual **TME400VMF_MAN_V12_06.2025_30.00.377.00-EN** of June 30th, 2025 for the TME 400-VM and TME 400-VMF turbine meters is a translation of the original German document.

Note The latest version of this manual (and other devices) can be downloaded at your convenience from our Internet page:

www.rmg.com.

Created	June 2018
9th Revision	November 2023
10th Revision	January 2024
11th Revision	June 2024

Document version and language

Document version	TME400VMF_MAN_V12_06.2025_30.00.377.00-EN June 30th, 2025
Language	EN

TABLE OF CONTENTS

1	INTRODUCTION	1
1.1	STRUCTURE OF THE MANUAL	1
1.2	PURPOSE OF THE MANUAL	2
1.2.1	Abbreviations	2
1.2.2	Symbols	3
1.2.3	Structure of notices	3
1.2.4	Working with the device	4
1.2.5	Risk assessment and minimization	9
1.2.6	Applicability of the manual	12
1.2.7	Transport	13
1.2.8	Scope of delivery	14
1.2.9	Storage	14
1.2.10	Disposal	14
1.3	OVERVIEW OF VERSIONS	15
1.3.1	Description	15
1.3.2	Device features	15
1.3.3	Firmware	16
1.3.4	Power supply	16
1.3.5	Area of application	17
1.3.6	Use of gas meters for different gases	18
1.4	AREAS OF APPLICATION	20
1.4.1	Working principle of the TME 400	20
1.4.2	Integrating the turbine meter into the pipeline	21
2	INSTALLATION	36
2.1	ELECTRICAL CONNECTIONS	36
3	TME 400	48
3.1	DISPLAY FIELD	48
3.1.1	Display test	49
3.1.2	Reset	49
3.1.3	Booting up	50
3.1.4	Battery replacement	52
4	OPERATION	55
4.1	OPERATION CONCEPT	55
4.1.1	Coordinate system	55
4.1.2	Display and coordinate system	57
4.1.3	Parameter protection	57
4.2	PROGRAMMING	59
4.2.1	Programming with the programming buttons	59
4.3	EQUATIONS IN THE TME 400	62
4.3.1	Variable description	62
4.3.2	Standard formula	62



4.3.3	<i>Coordinates in context</i>	62
4.4	SPECIAL SETTINGS	75
4.4.1	<i>Configuration of the current output</i>	75
4.5	RMGVIEWTME	76
5	TECHNICAL DATA	77
5.1	DEVICE TYPES.....	77
5.2	INPUTS	77
5.2.1	<i>Power supply</i>	77
5.2.2	<i>Pulse In measuring inputs (sensor 1 / 2)</i>	78
5.3	OUTPUTS	78
5.4	DATA INTERFACE	78
5.5	CURRENT LOOP CONNECTION	79
5.6	CABLE	80
5.7	CABLE CONNECTION	80
5.8	GROUND.....	82
5.9	ISOLATING AMPLIFIER TYPE Ex-400.....	84
5.10	OVERVIEW OF MATERIALS IN USE	85
6	ERROR MESSAGES	86
	APPENDIX	88
A	MODBUS	88
B	STRUCTURE OF THE ARCHIVES	96
B1	ARCHIVE SIZE	96
B2	ARCHIVE TYPES.....	96
B2.1	PARAMETER ARCHIVES.....	97
B2.2	EVENT ARCHIVES	97
B2.3	MEASURED VALUES ARCHIVES	99
B3	CALCULATION OF THE STORAGE SIZE	102
B4	ARCHIVE HEADER.....	102
B5	READING THE ARCHIVE DATA VIA MODBUS.....	105
C	DIMENSIONS	107
D	MEASURING RANGES FOR TME 400-VMF/ TME 400-VCF	112
E	MEASURING ACCURACY FOR TME 400-VM	113
F	TYPE PLATE	115
G	SEAL DIAGRAMS	118
H	LATER INSTALLATION OF THE POWER MODULE	119
I	SPARE PARTS AND ACCESSORIES	121
J	CERTIFICATES AND APPROVALS	134

1 Introduction

1.1 Structure of the manual

The introduction of this manual comprises two parts. The first part lists general specifications; the symbols used in the manual and the structure of notices are presented and a risk assessment is provided. The differences between the TME 400-VM and TME 400-VMF turbine meters are explained. If there is no explicit reference to differences, the TME 400 is superordinate for both versions of the turbine meter.

Note

This manual refers to the TME 400-VM and TME 400-VMF instead of the complete turbine meter.

In addition, the first part includes specifications for the transport and storage of the TME 400. The second part of the introduction describes the features and areas of application of the TME 400; basic standards are listed and the pressure and temperature ranges in which the TME 400 can and may be used are pre-adjusted.

The second chapter describes the electrical and mechanical commissioning of the TME 400. An explanation of how to achieve the reliable commissioning of the meter and high precision is provided.

The third chapter explains the displays of the TME 400. It explains resetting, booting and replacement of the battery.

The settings of the TME 400 are explained in chapter four. In particular, all adjustable parameters are provided there with some explanations.

The fifth chapter summarizes the technical data and the sixth chapter provides a list of error messages.

The appendix provides details about the Modbus, measurements, type plate and seal plans. Then the certificates and approvals are listed.

1.2 Purpose of the manual

This manual provides information that is necessary for fault-free and safe operation.

The TME 400 was designed and produced according to the state of the art and generally recognized safety standards and directives. However, its use can entail dangers that are avoidable by complying with this manual. The device must only be used as intended and in technically sound condition.

Warning

Unintended use voids all warranty claims and the TME 400 can also lose its approvals.

1.2.1 Abbreviations

The following abbreviations are used:

TME 400-VM	The TME 400-VM is a turbine meter which is used for non-custody-transfer volume measurement (V olume M asurement) of the operating volume of non-aggressive gases and combustion fuels is used.
TME 400-VMF	The TME 400-VMF is a turbine gas meter that is used in custody-transfer applications (F iscally). The designation TME 400-VMF comprises all turbine meters.
TME 400-VC	The TME 400-VC also enables calculation of the standard volume flow (V olume C orrector) from the operating volume flow in non-custody-transfer applications.
TME 400-VCF	The TME 400-VCF is used in custody-transfer applications (F iscally). In addition to the turbine meter, the TME 400-VCF designation also includes the volume corrector.

Note

This manual only describes the TME 400-VM and TME 400-VMF.

MessEG	Measurement and Calibration Act Law on the marketing and provision of measuring devices in the market, their use and calibration, valid since 1/1/2015
MessEV	Measurement and Calibration Regulation Regulation on the marketing and provision of measuring devices in the market and on their use and calibration; 12/11/2014
MID	Measurement Instruments Directive
PTB	Physikalisch-Technische Bundesanstalt [German National Test Authority]
Vo	<u>o</u> riginal meter reading (<u>V</u> olume) of a mechanical counter
approx.	approximately
max.	maximum
min.	minimum

3

1.2.2 Symbols

The following symbols are used:

1, 2, ...	Identifies steps for work tasks
..	

1.2.3 Structure of notices

The following notices are used:

 Danger
<p>This warning notice informs you of imminently threatening dangers that can arise due to misuse/operator error. If these situations are not avoided, death or severe injuries can occur.</p>

 **Warning**

This warning notice informs you of potentially dangerous situations that can arise due to misuse/operator error. If these situations are not avoided, minor injuries can occur.

 **Caution**

This notice informs you of potentially dangerous situations that can arise due to misuse/operator error. If these situations are not avoided, damage to the device or nearby property can occur.

Note

This notice informs you of potentially dangerous situations that can arise due to misuse/operator error. If these situations are not avoided, damage to the device or nearby property can occur.

This notice can provide you with helpful tips to make your work easier. This notice also provides you with further information about the device or the work process in order to prevent operator error.

1.2.4 Working with the device

1.2.4.1 Safety notices Danger, Warning, Caution and Note

 **Danger**

All of the following safety notices must be observed!

Disregard of the safety notices can result in danger to the life and limb or environmental and property damage.

Bear in mind that the safety warnings in this manual and on the device cannot cover all potentially dangerous situations, because the interaction of various conditions can be impossible to foresee. Merely following the instructions may not suffice for correct operation. Always remain attentive and consider potential consequences.

- Read this operating manual and especially the following safety notices carefully before working with the device for the first time.
- Warnings are provided in the operating manual for unavoidable residual risks for users, third parties, equipment or other property. The safety instructions used in this manual do not refer to unavoidable residual risks.
- Only operate the device in fault-free condition and in observance of the operating manual.
- Compliance with local statutory accident prevention, installation and assembly regulations is also mandatory.

⚠ Caution

All notices in the manual must be observed. Use of the TME 400 is only permitted in accordance with the specifications in the operating manual. RMG assumes no liability for damages arising due to disregard of the operating manual.

⚠ Danger

Service and maintenance tasks or repairs that are not described in the operating manual must not be carried out without prior consultation with the manufacturer. The device must not be opened forcefully.

⚠ Caution

The TME 400 is approved for custody-transfer applications. For this purpose, it is sealed before deliver and settings specified by the approval authority are locked. These seals, software or hardware locks must not be damaged, destroyed or removed!

In this case, the TME 400 loses its official certification!

The TME 400 can only be approved for officially certified operation after a renewed inspection by an officially recognized inspection authority or calibration officials and an additional inspection of additional settings. The calibration official must re-apply the seals after the inspection.

Observe the following, in particular:

- Changes to the TME 400 are not permitted.
- The technical specifications must be observed and followed for safe operation. Performance limits must not be exceeded (*chapter 5 Technical data*)
- For safe operation, the TME 400 must only be used in the scope of the intended use (*chapter 1.3 Overview of versions*).
- The TME 400 complies with current standards and regulations. However, danger can arise with misuse.

6

1.2.4.2 Dangers during commissioning

Initial commissioning

The initial commissioning must only be carried out by specially trained personnel (training by RMG) or RMG service personnel.

Note

An acceptance test certificate must be created during the commissioning. This, the operating manual and the EU Declaration of Conformity must be stored so that they are always readily available.

All sharp edges on the device were removed, insofar as possible. However, personal protective equipment provided by the operator must be worn during all work.

Danger

Install the device as specified in the operating manual. If the device is not installed as specified in the operating manual, there may be a risk that adequate explosion protection is not provided.

The explosion protection is lost!

⚠ Danger

Inadequately qualified persons working on the equipment are unable to correctly estimate dangers. Explosions can be triggered. Only work on the equipment if you have the appropriate qualifications.

Components can be damaged if you do not use suitable tools and materials. Use tools that are recommended for the respective work in the operating manual.

Mechanical installation	Mechanical installation must only be performed by appropriately qualified technicians.
Electrical installation	Installation on electrical components must only be carried out by qualified electricians.
Mechanical and/or electrical installation	These qualified personnel require training specifically for work in hazardous areas. Qualified personnel are persons who have training / education in accordance with DIN VDE 0105, IEC 364 or comparable standards .

⚠ Danger

Installation and removal of the TME 400 must only take place in an explosion-free, pressure-free atmosphere. The descriptions in the operating manual must be observed. In general, it is recommended that the replacement should only be carried out by RMG Service.

A leak test must be carried out after work on pressurized components.

All of the above points also apply to repair and maintenance tasks and in general when opening the meter is necessary.

Flange fastening elements, fastening screws, screw couplings and check valves, the oil supply, pressure relief connections, valves, HF pulse generators, protective pipes and swivel adapters must not be loosened during operation.

1.2.4.3 Dangers during maintenance and repair

Operating personnel	The operating personnel use and operate the device in the scope of the intended use.
Maintenance personnel	Work on the device must only be carried out by qualified personnel who can carry out the respective tasks on the basis of their technical training, experience and familiarity with the applicable standards and requirements. These qualified personnel are familiar with the applicable statutory regulations for accident prevention and can independently recognize and avoid potential dangers.
Maintenance and cleaning	Maintenance and cleaning must only be performed by appropriately qualified technicians.

⚠ Danger

Inadequately qualified persons working on the equipment are unable to correctly estimate dangers. Explosions can be triggered. If work on live equipment must be conducted in hazardous areas, sparks that are created can trigger an explosion.

⚠ Danger

**The device can be damaged if it is not cleaned as specified in the operating manual. Only clean the device as specified in the operating manual.
Components can be damaged if you do not use suitable tools. The explosion protection is lost.**

- Only clean the device with a damp cloth!**

⚠ Danger

The TME 400 must only be used as intended! (*Chapter 1.3 Overview of versions*). Prevent use of the TME 400 as a potential climbing aid or use of attachments of the TME 400 as potential handles!

1.2.4.4 Qualification of personnel

Note

In general, the following is recommended for all persons working with or on the TME 400:

- Training / education for work in hazardous areas.
- The capacity to be able to correctly estimate dangers and risks when working with the TME 400 and all connected devices. Possible dangers include components that are under pressure and consequences of incorrect installation.
- Recognition of dangers that can arise from the flow medium that is used.
- Training / education by RMG for work with gas measuring devices.
- Education / instruction in all national standards and directives to be complied with for the work to be carried out on the device.

1.2.5 Risk assessment and minimization

According to assessment by qualified employees of RMG, the TME 400 is subject to risks during its use. Risks can arise, for example, due to high pressures and occasionally due to pressures that are too low. Work outside of the permissible temperature range can also lead to dangers. Impermissible current and voltage values can trigger explosions in hazardous areas. The risk assessment requires an emptying and ventilation of the pipeline for connection with installation and removal of a turbine. Then and only then is it assured that there is not an hazardous gas mixture in the pipeline. Naturally, work must only be carried out by trained personnel (see *chapter 1.2.4.4 Qualification of personnel*), who are also trained to recognize suitable tools and use them exclusively. The risks were summarized alongside development and measures were taken to minimize these risks.

Measures for risk minimization:

- All pressurized parts are designed in accordance with AD 2000 rules and regulations, Pressure Equipment Directive, Annex 1
- The complete pressure design has been inspected by TÜV Hessen
- All pressurized parts have been manufactured with a material certificate; there is an uninterrupted change of batch tracing of pressurized components
- The mechanical properties of all relevant pressurized components have been subjected to tension tests, notch impact bending tests and hardness tests

1 Introduction

- Non-destructive testing was also carried out: X-ray and ultrasonic inspection of the meter housing for defective points in material, surface crack testing with magnetic powder and a color penetration process
- Strength tests for components were conducted at 1.5 times the nominal pressure for the pressure testing; the leak testing for the assembly was conducted at 1.1 times the nominal pressure. Certificates were issued for successfully passed tests
- The maximum operating pressure and the permissible temperature range are specified on the type plate of the device. Operation of the device is only permitted within these specified ranges.
- A maximal temperature difference of $\Delta T \leq 100^\circ\text{K}$ between the inside and outside of the TME 400 must be respected.
- Additional external forces and torques were not taken into account in the pressure dimensioning.
- In the event that the pressure equipment is to be marketed and put into operation as an assembly within the meaning of the Pressure Equipment-Directive, an examination of the assembly must be provided at the latest during the final and pressure tests.
Otherwise, the commissioning inspector must explicitly point out that a test of the equipment location with safety function still has to be performed at the installation site.

⚠ Danger

The following applies for work in hazardous areas (all zones):

- The pulse generators of the turbine meter must be connected to intrinsically safe power circuit only.
- Only tools that are approved for Ex Zone 1 are permitted for maintenance and repair tasks.
- Otherwise, work must only be carried out when there is not an explosive atmosphere.
- The risk of ignition due to impact or friction must be avoided.
- Work on devices which are used in hazardous areas must be carried out by qualified electrical engineers with special capabilities for work in hazardous areas.
- The wiring / installation in hazardous areas must only be carried out by trained personnel in accordance with EN60079-14 and in observance of national regulations.
- Qualified persons must satisfy the definitions in accordance with DIN EN 0105 or IEC 364 or directly comparable standards.
- If one or more power circuits are used, it must be ensured that the permissible limit values according to the EC type approval certificate are not exceeded when choosing the cables.
- Every Ex signal circuit must be routed with a dedicated cable which must be guided through the appropriate PG screw coupling.
- Permanent installation of the intrinsically safe cable is mandatory.

⚠ Danger

In addition, the following applies for work in hazardous areas (all zones):

- Only trained and instructed personnel are permitted. Work on the measuring system must only be carried out from qualified persons and inspected by responsible qualified supervisors.
- Qualified persons have been authorized by the person responsible for safety of personnel to carrying out such work on the basis of their training, experience or instruction and familiarity with applicable standards, provisions, accident prevention regulations and system conditions. It is essential that these persons are able to recognize and avoid potential dangers in good time.

1.2.6 Applicability of the manual

This manual describes the TME 400. TME 400 is generally only part of a complete system. The manuals of the other components of the system must be observed. If you find contradictory instructions, contact RMG and/or the manufacturers of the other components.

Note

Ensure that the power data of the current connection matches the specifications on the type plate. Ensure that the limit values specified in the conformity certificate (see appendix) for the devices to be connected are not exceeded.

Observe any applicable national regulations in the country of use. Use cable that is appropriate for the cable fittings.

Danger

Only work on the equipment if you have the appropriate training and qualifications.

Attention: Risk of destruction due to body electricity, e.g. due to the rubbing of clothing.

1.2.6.1 Danger during operation

Observe the specifications of the system manufacturer and/or system operator.

1.2.6.2 Dangers of operation in EX areas

Only operate the device in fault-free and complete condition.

If you make technical changes to the device, safe operation can no longer be guaranteed.

Danger

Only use the device in its original condition. The TME 400 is permitted for operation in Ex Protection Zone 1, but only within the permissible temperature range (*chapter 1.3.5.2 Temperature ranges*).

1.2.6.3 Responsibility of the operator

As the operator, you must ensure that only adequately qualified personnel work on the device. Ensure that all employees who work with the device have read and understood this manual. You are also obligated to train personnel regularly and inform them of the dangers. Ensure that all work on the device is carried out exclusively by qualified persons and inspected by responsible qualified supervisors. The responsibilities for installation, operation, fault rectification, maintenance and cleaning must be clearly regulated. Instruct your personnel with regard to the risks involved with working with the device.

1.2.7 Transport

The device is packaged specific to the transport requirements for each customer. Ensure safe packaging that absorbs light impact and vibrations is used for any further transport. Nevertheless, inform the transport company that all types of impact and vibrations should be avoided during transport.

Warning

Risk of injury during transport

Any foot screws must be mounted if they are provided as a transport safeguard to prevent rolling and tipping. Additional measures must be taken to ensure that impermissible rolling and tipping are prevented.

Only use the provided lifting eyes / ring screws to lift the meter. Please observe the relevant permissible loads for the lifting equipment. Prior to lifting, ensure that the load is securely fastened. Do not stand under suspended loads.

The device can slip, topple over or fall down when being lifted and set down. The device can fall over if the bearing capacity of the lifting equipment is disregarded. There is a risk of severe injury for nearby persons.

If the device is delivered on a Euro pallet, the device can be transported on the pallet using a pallet truck or forklift.

The gas meters and accessories must be protected from jarring and vibrations during transport.

The gas meters or any inlet/outlet pieces have a flange as an end piece. The flanges are sealed with a protective sticker or fitted with a plastic dummy plug. The protective stickers and/or dummy plugs must be removed without leaving any residue prior to installation in the pipeline. Residue from this film changes the flow and causes measuring errors!

This protection must be re-applied to the flanges for transport or storage of the device.

1.2.8 Scope of delivery

The scope of delivery can differ depending on the optional orders. The following is "normally" included in the scope of delivery:

Part	Quantity
TME 400-VM (or TME 400-VMF) turbine meter	1
1 Lubricating oil bottle	Optional
Lubricating instructions	1
Manual	1
Test log	1
Calibration certificate	1
Material test certificate	1
Strength test certificate 3.1.	Optional

1.2.9 Storage

Avoid extended periods of storage. After storage, inspect the device for damage and test for correct function. Contact the RMG service department to arrange for inspection of the device after a storage period of longer than one year. For this purpose, return the device to RMG.

Note
<p>Storage must take place in a dry and protected room.</p> <p>It must be ensured that all open pipes are sealed.</p>

1.2.10 Disposal

Dispose of the **packaging and protective material** (e.g. drying mats) as well as the **parts and devices** supplied in an environmentally friendly manner in accordance with the country-specific laws, standards and guidelines.

When disposing of the device, observe the overview of the materials used on page 85.

Before disposing of the device, remove the **batteries**, mask their contacts and dispose of the batteries separately.

Residual amounts of **lubricating oil** in the bottles supplied must also be disposed of separately.

Make sure that your disposal company is authorized to dispose of the relevant parts and materials.

1.3 Overview of versions

1.3.1 Description

15

The **TME 400-VM** is a turbine meter which is used for volume measurement of the operating volume of non-aggressive gases and burnable gas. The operating volume flow is determined based on the turbine speed, which is scanned by means of a Wiegand or Reed sensor element and then added together in internal archives. The result is registered in an electronic meter.

There are a high-frequency (HF) and a low-frequency (LF) output, where the HF output is preferably used as a flow sensor for control tasks and remote transmission. In addition to these outputs, the TME 400 VM has a serial RS 485 interface for digital data readings and parameterization. The TME 400-VM is used in **non-custody-transfer** applications.

The **TME 400-VMF** (MID) is the turbine meter for custody-transfer applications and has an equivalent function and operating method to the TME 400-VM. The essential difference is the 2-channel measuring head version. It is used in **custody-transfer applications**.

1.3.2 Device features

TME 400-VM

- Non-custody-transfer measurements
- Electronic meter
- Alarm output
- Optionally available in a version with remote meter (distance from meter head to meter: 10 m; see *appendix C Dimensions*)
- 2x pulse inputs selectable for Reed, Wiegand and external pulse transmitters (remote meters)
- 1x contact input
- 1x HF output (input pulse of pulse input 1 is output with defined pulse width of 1 ms)
- 1x LF output with defined pulse width (20 ms, 125 ms or 250 ms)
- 1x RS485 with external power supply
- 1x optional power module
- Power supply via 3.6V lithium cell or an external power supply which is assigned to the RS485 interface (supply via power module alone is not adequate and a battery is required for support)

- Archive memory for events, parameters, measurements

TME 400-VMF

In addition to the features of the TME 400 VM, this version can be used for custody-transfer applications.

16

1.3.3 Firmware

The currently delivered devices have either firmware version 1.12 or 11.12 installed, depending on the components used in the index head. With the devices of the type TME 400-VM(F) there is no functional difference between the two versions. The installed version is shown in coordinate G02.

1.3.4 Power supply

1.3.4.1 Battery-operated device

The TME 400 is equipped with a replaceable 3.6 V lithium battery. The device is designed for continuous operation for approximately 10 years. To achieve this, the devices may be operated for a maximum of 15 minutes per day with input pulses of 1 Hz.

Since the battery in the device is supplied with an insulating strip (positive pole protection), this strip must be removed before commissioning!

1.3.4.2 Battery-operated device with additional external power supply

An electric supply of the TME 400 via the 4-20mA current loop reduces the power consumption from the batterie and typically extends the service life of the battery to more than 12 years.

If the TME 400 is additionally electrical powered by the RS485 interface, the service life of the battery is typically extended to clearly more than 12 years.

1.3.4.3 Battery replacement indicator

The remaining battery life is determined by means of an internal calculation. An indicator in the display appears when it is time to replace the battery. Battery replacement is described in *chapter 3.1.4 Battery replacement*. In parameter G20 *Date of last battery change* the date of the last battery change is displayed (see *chapter 4.3.3 Coordinates in context*).

Note

In case of a loss of the external power supply, the TME 400 is supplied by the buffer battery. The battery symbol is blinking in this case.

1.3.5 Area of application

The TME 400 is approved for use in hazardous areas with the following mark:



II 2G Ex ia IIC T4 Gb

The EC type approval certificate is:

TÜV 17 ATEX 207566 X
IECEX TUN 18.0009 X

The corresponding conformity certificates are provided in the annex. The RMG contact information is provided on the second and last page.

1.3.5.1 Installation and mounting position

The TME 400-VM and TME 400-VMF can be supplied with DIN and ANSI connections. Up to nominal diameter DN 200, the installation position of the turbine meter with permanent lubrication can be selected as required. From nominal diameter DN 250, the meter must be installed in the ordered installation position. It must also be ensured that the filling opening of the lubrication faces upwards.

1.3.5.2 Temperature ranges

The turbine meter TME 400 in standard version is approved for the following temperature ranges.

Temperature ranges	
Medium temperature	-25°C to +55°C
According to ATEX (T _{amb})	-25°C to +55°C (II 2G Ex ia IIC T4)
According to PED 2014/68/EU	-20°C to +80°C (spheroidal graphite iron) -40°C to +80°C (cast steel) -40°C to +80°C (stainless steel) -10°C to +80°C (welded version and round steel material)
Pressure safety for DN25 according to sound engineering practice, see PED 2014/68/EU, sec. 4, subsec. 3	-40°C to +60°C (aluminum)
Lower temperature limits are available on request with the welded version and round steel material.	

⚠ Caution

Direct solar radiation must be avoided.

Note

If different temperature ranges apply simultaneously, the smallest specified range applies for the overall system. This is also marked on the type plate.

1.3.6 Use of gas meters for different gases

Gas	Symbol	Tightness at 0°C and 1.013 bar	Meter housing	Comments
Natural gas		0.8	Standard	
City gas			Standard	
Methane	CH ₄	0.72	Standard	
Ethane	C ₂ H ₆	1.36	Standard	
Propane	C ₃ H ₈	2.02	Standard	
Butane	C ₄ H ₁₀	2.70	Standard	
Air		1.29	Standard	
Argon	Ar	1.78	Standard	
Helium	He	0.18	Standard	
Carbon dioxide (dry)	CO ₂	1.98	Standard	
Nitrogen	N ₂	1.25	Standard	
Hydrogen	H ₂	0.09	Standard	up to 100% Generally, a reduced measuring range
Ethylene (gaseous)	C ₂ H ₄	1.26	Special	Special version (also for humid gases): Teflon coating, special lubrication, special material, etc.
Biogas			Special	
Sour gas			Special	
Digester gas / sewage gas			Special	
Sulfur dioxide	SO ₂	2.93	Special	

The components of the gases must be within the concentration limits according to EN 437:2009 for test gases. Safe operation is guaranteed with these specified gases.

Other gases on request.

1.3.6.1 Suitability and compatibility for natural gas containing H₂

The TME 400 can be used in hydrogen-containing natural gas up to pure hydrogen. There are no safety-related concerns for this use.

Notice

In accordance with the German TR-G19 – the TME 400 is suitable and approved for use in custody transfer applications – in natural gases with a maximum hydrogen content of 10 mol-%, with the accuracy specified in *chapter 1.4.2.10 Measuring accuracy*.

19

Since there are currently no certified test rigs in Germany to calibrate meters with higher hydrogen-containing gases, an accuracy above 10 mol-% cannot be tested or certified.

Not custody transfer measurements are of course possible in natural gases with a hydrogen content above 10 mol%. However, a reduced measuring range must be taken into account if applicable. Please contact RMG for further information.

1.4 Areas of application

The following chapter provides handling instructions for the TME 400 turbine meter for the purpose of safe and reliable operation of the device.

Note

Some of the settings described below must not be made until you have read the explanations in *chapter 4 Operation*.

1.4.1 Working principle of the TME 400

The working principle of a mechanical turbine meter is based on the measurement of the gas velocity of the flowing gas which powers a turbine wheel. The speed of the turbine within the measuring range (Q_{\min} - Q_{\max}) is approximately proportional to the mean gas velocity and thus the flow rate. The number of rotations, therefore, is a measurement for the gas volume flowing through.

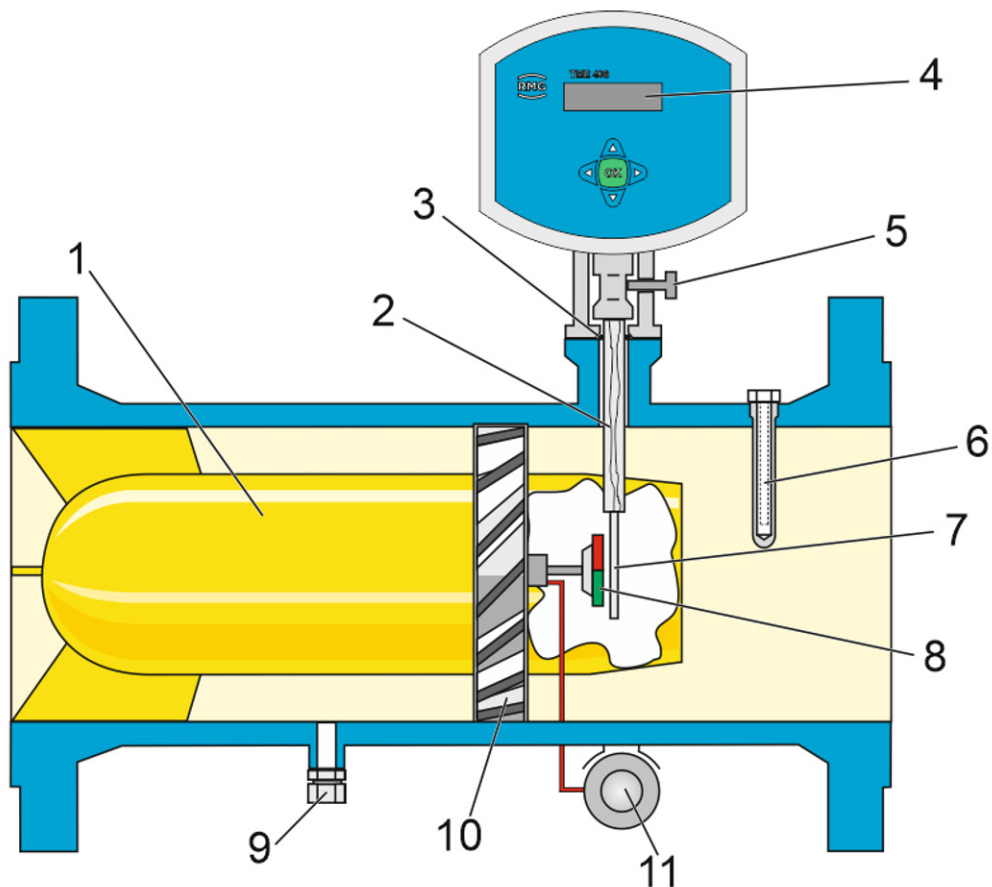

- | | | | |
|---|--|----|---------------------|
| 1 | Flow straightener | 7 | Sensor |
| 2 | Sensor sleeve | 8 | Permanent magnet |
| 3 | O-ring | 9 | Pressure connection |
| 4 | Counter | 10 | Turbine wheel |
| 5 | Clamp screw | 11 | Oil pump |
| 6 | Thermowell for temperature comparison (fiscal) | | |

Figure 1: Turbine meter sectional drawing

There is a permanent magnet on the end disc of the turbine shaft which induces a voltage pulse in the Wiegand sensor with every rotation. This pulse is supplied to the measuring unit of the meter head, which detects the operating volume flow directly as a main totalizer and determines the gas volume flowing through the meter by adding up the pulses and division by the meter factor (number of pulses per m³). This operating volume is shown in the display of the TME 400.

Note

The unchanged signal frequency of the sensor element is output at the HF output.

The LF output transmits this HF frequency with a variable scaling factor (*chapter 4.3.3.1 Volume / Meters*).

1.4.2 Integrating the turbine meter into the pipeline

Turbine meters from RMG are equipped with connecting flanges. For a secure connection, the connection dimensions of the flanges of the pipelines to be connected must match the connection dimensions of the flanges of the device.

- ANSI pressure levels: flange connection dimensions correspond to the standard ASME B 16.5.
- DIN pressure levels: flange connection dimensions correspond to the standard DIN EN 1092.

1.4.2.1 Seals

- Flat seals: $k_0 \times K_D = 20 \times b_D \mid k_1 = 1.3 \times b_D \text{ [N/mm]}$
- Grooved seals: $k_0 \times K_D = 15 \times b_D \mid k_1 = 1.1 \times b_D \text{ [N/mm]}$
- Spiral seals: $k_0 \times K_D = 50 \times b_D \mid k_1 = 1.4 \times b_D \text{ [N/mm]}$
- Octagonal ring-joint seal: $K_D = 480 \text{ N/mm}^2$

Refer to the tables below for the recommended dimensions.

Flat seals (DIN 2690 / EN 12560-1 Form IBC)

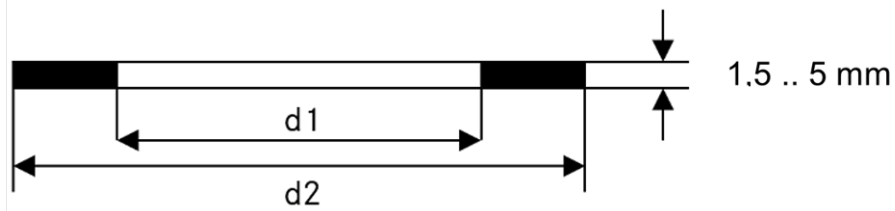

			PN 10	PN 16	ANSI 150	PN 25	PN 40
DN	d1	d2					
50	2"	77	107	107	105	107	107
80	3"	90	142	142	137	142	142
100	4"	115	162	162	175	168	168
150	6"	169	218	218	222	225	225
200	8"	220	273	273	279	285	292
250	10"	274	328	330	340	342	353
300	12"	325	378	385	410	402	418
400	16"	420	490	497	514	515	547
500	20"	520	595	618	607	625	628
600	24"	620	695	735	718	730	745

Grooved seals (EN 12560-6 with centering ring)

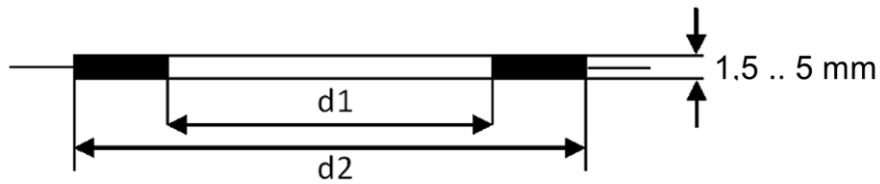

		ANSI 300 / ANSI 600		PN 64	
DN		d1	d2	d1	d2
50	2"	69.8	88.9	65	87
80	3"	98.4	123.8	95	121
100	4"	123.8	154.0	118	144
150	6"	177.8	212.7	170	204
200	8"	228.6	266.7	220	258
250	10"	282.6	320.7	270	315
300	12"	339.7	377.8	320	365
400	16"	422.3	466.7	426	474
500	20"	530.2	581.0	530	578
600	24"	631.8	682.6	630	680

Spiral seals (EN 12560-2 with centering ring)

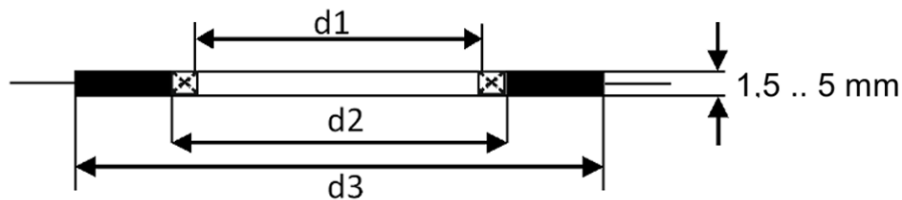

		ANSI 300			PN 64			ANSI 600		
DN	d1	d2	d3	d1	d2	d3	d1	d2		
50	2"	51	69.9	85.9	54	66	84	51	69.9	85.9
80	3"	81	101.6	120.7	86	95	119	81	101.6	120.7
100	4"	106.4	127.0	149.4	108	120	144	106.4	120.7	149.4
150	6"	157.2	182.6	209.6	162	174	200	157.2	174.8	209.6
200	8"	215.9	233.4	263.7	213	225	257	215.9	225.6	263.7
250	10"	268.3	287.3	317.5	267	279	315	268.3	274.6	317.5
300	12"	317.5	339.9	374.7	318	330	366	317.5	327.2	374.7
400	16"	400	422.4	463.6	414	426	466	400	412.8	463.6
500	20"	500	525.5	577.9	518	530	574	500	520.7	577.9
600	24"	603.3	628.7	685.8	618	630	674	603.3	628.7	685.8

For flanges according to ASME to be observed:

- Gasket type: flat gasket tanged sheet metal/graphite or similar
- Gasket dimensions: according to ASME B16.21
- Seal data: design seat tension
 $Y_{\max} = 45 \text{ MPa}$, sealing factor $m_{\max} = 2.5$

Note

When flange seals which protrude into the pipeline are used for turbine meters, the measuring accuracy can be influenced negatively. Ensure that the flange seals do not protrude beyond the seal surfaces into the pipeline.

Danger

Gas escape due to incorrect seal

If incorrect flange seals are used for the assembly of turbines, an explosive gas mixture can form due to leaks.

Danger of poisoning and explosion!

In addition, the stress on the flange is increased to an impermissible level when tightening the thread bolts.

Ensure secure fastening/attachment of the TME 400 during assembly in order to avoid crushing. Ensure that you keep your fingers (or other body parts) away from these openings and gaps when pulling the flanges together.

1.4.2.2 Screws

	Temperature ranges for screws and nuts			
	-10°C to +80°C	-40°C to +80°C		
Pressure levels		Option 1	Option 2	Option 3
up to and including 40 bar	Screws according to DIN EN ISO 4014 in material 5.6 Nuts according to DIN EN ISO 4032 in material 5-2	Screws according to DIN EN ISO 4014 in material 25CrMo4, Nuts according to DIN EN ISO 4032 in material 25CrMo4		
40 bar or higher	Threaded bolts according to ANSI B1.1 material ASTM A 193 degree B7, Nuts according to ANSI B1.1 material ASTM A 194 degree 2H,	Threaded bolts according to ANSI B1.1 material ASTM A 320 degree L7, Nuts according to ANSI B1.1 material ASTM A 320 degree L7,	Threaded bolts according to ANSI B1.1 material 42CrMo4 Nuts according to ANSI B1.1 material 42CrMo4	Reduced shaft screws according to DIN 2510 material 25CrMo4, Nuts according to DIN 2510 material 25CrMo4

For flanges according to ASME to be observed > -10°C:

Screw material SA.193 B7/B7M according to ASTM A193 Grade B7 or comparable materials.

Note

Reduced shaft screws must only be used for devices in the area of application of the Pressure Equipment Directive.

The durability of the flange connection was verified using the screws listed in this chapter in combination with the seals listed in the previous chapter with the following maximum material characteristic data according to AD200 rules and regulations. Other screw/flange variants were not tested.

Malfunctions can occur with incorrect seals.

1.4.2.3 Meter housing material

Cast steel or round steel material, depending on the pressure level and nominal diameter. Aluminum or stainless steel for the screw-type versions.

1.4.2.4 Installation

Note
Installations disturbing the gas flow directly upstream of the turbine meter must be avoided (see DVGW guideline G 492 II and PTGB guideline G 13).

An inlet pipe of at least 2 x DN is required upstream from the turbine meter TME 400. The inlet pipe must be designed as a straight pipe section with the same nominal diameter as the meter. With heavy upstream perturbations, installation of straighteners is recommended (refer to the table on the next page). A pipe or bend with the nominal diameter of the meter having a total length of 2 x DN must be arranged downstream from the meter.

Temperature measuring devices must be installed at a distance of at least 1 x DN or at least 300 mm with nominal diameters \geq DN 300.

If there is perturbation (e.g. a gas pressure control device) upstream from the inlet pipe, a perforated plate straightener is also necessary. Perforated plate straightener according to ISO 5167-1 or the type RMG LP-35, which cause a pressure loss by a factor of 2.5 in comparison with the standard straightener, can be used.

Recommended installation with straightener

Perforated plate straightener LP 35

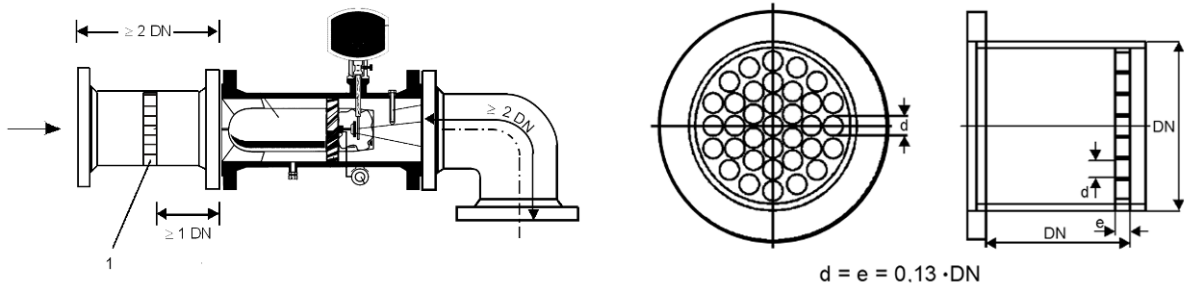

1 Perforated plate straightener

- The opening angle of the reducing or expansion pieces which are installed upstream from the TME 400 turbine meter must not be more than 30°.

Note
If necessary, a screen must be installed before the inlet pipe of the meter for protection of the turbine meter from foreign objects which may be present in the gas flow. The screen can be, for example, a perforated plate/filter of \varnothing 0.15 mm.

⚠ Danger

Protect the turbine meter from damage caused by high pressure changes fluctuations in the flow, e.g. if the downstream pipeline system is filled or blown off.

⚠ Danger

Welding on the line must only take place at a safe distance from the meter. Extreme temperatures in the line near the meter can cause permanent damage to the meter.

⚠ Danger

Establish all electrical connections between meters and amplifiers or flow computers as specified in the installation manual. Ensure that the connections are intrinsically safe.

⚠ Caution

Liquids remaining in the line after hydrostatic testing can damage internal parts of the meter.

If hydrostatic testing is not possible, the turbine meter must be replaced with a pipe section. Ensure that there is no liquid remaining in the line above the meter after the hydrostatic testing.

1.4.2.5 Threshold values

The following threshold values are recommended for maximum durability and the highest measuring accuracy:

Note	
Maximum overload	< 20% above Q_{\max} , short-term (< 30 sec)
Maximum flow rate changes and/or impact loads	< $0.01 \cdot Q_{\max}/\text{sec} \hat{=} 1\%$ of Q_{\max}/sec e.g. start-up 0 - 100%: > 100 sec
Maximum pressure change:	< 0.1 bar/sec
Maximum flow pulsation:	< 5%
Particle size in the gas flow:	< 5 μm
Lubrication:	Refer to lubrication chapter Intervals depend on the status of the gas (condensate, rust, dust)
Vibration / mech. vibration:	< 1 mm/sec (vibration speed)

These measures must be determined and checked during commissioning, before filling, during the start-up and run-in phase of the meter and evaluated, in particularly with simultaneous occurrence of multiple of these threshold values. Intervention in the system for improvement of measuring conditions must be carried out when the aforementioned threshold values are reached.

Note	
<p>The operator should record the overall measurement data (meter and operating data) during the entire operation in order to be able to recognize causes of potential damage at an early stage and to intervene in good time.</p> <p>Remedy and/or relief of critical operating statuses can be achieved, for example, with the following measures:</p> <ul style="list-style-type: none"> • Start-up screen (MW < 0.15 mm) • Filter • Meter protection perforated plates (\varnothing 3 - 4 mm) • Valves with control drive (flow change) • Check valves (pulsation, backflow) 	

1.4.2.6 Technical guideline G13

The installation conditions for new systems according to TRG G13 and the facilitated installation conditions for RMG turbine meters are compared in the table below.

Type of upstream perturbation	Installation conditions according to TR G13	Installation conditions for RMG type TME 400 meters	Comments
none	Inlet ≥ 5 DN Outlet ≥ 2 DN	Inlet ≥ 2 DN Outlet ≥ 2 DN	The outlet pipe can also be designed as a bend.
	Inlet ≥ 10 DN		Perturbation upstream from this inlet pipe does not have to be factored in when the requirements for an alternating and pulsing flow are fulfilled.
Bend	Inlet ≥ 5 DN	Inlet ≥ 2 DN	
Bends in 2 planes	Inlet ≥ 5 DN plus 2 perforated plate straighteners or a bend straightener	Inlet ≥ 2 DN	
Gas pressure regulating device with an attenuator	Inlet ≥ 5 DN	Inlet ≥ 2 DN plus 1 perforated plate straightener	
Gas pressure regulating device without an attenuator	Inlet ≥ 5 DN plus 2 perforated plate straightener	Inlet ≥ 2 DN plus 1 perforated plate straightener	
Diffuser	Inlet ≥ 5 DN plus 1 perforated plate straightener	Inlet ≥ 2 DN	
Diffuser with swirling flow	Inlet ≥ 5 DN plus 2 perforated plate straightener	Inlet ≥ 2 DN	

1.4.2.7 Perforated plate straightener

The following options are available for the straighteners:

Perforated plate straightener RMG L1 - L3 according to ISO 5167-1 and DIN 1952

Perforated plate straightener RMG LP-35

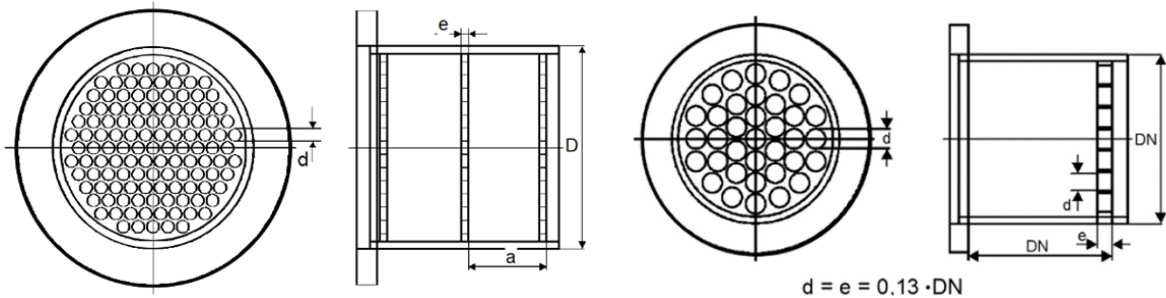

Characteristics	ISO/DIN	L1-L3	RMG LP-35
Hole diameter d	$d \leq 0.05 D$	$0.04 D$	$0.13 D$
Plate thickness e	$e \geq d$	$e = d$	$0.13 D$
Clearance a	$0.5 D \leq a \leq 1 D$	$0.5 D$	-
Opening ratio m	$0.2 \leq m \leq 0.4$	0.3	0.6
Dynamic pressure loss Δp		$5 - 15 (c^2 \rho / 2)$	$2 - 15 (c^2 \rho / 2)$

With the RMG turbine meters, these straighteners fulfill the requirements of technical guideline G 13 and are approved with approval number D 81 / 7.211.10 for turbine meters.

1.4.2.8 Standards / guidelines

All RMG turbine meters have passed upstream perturbation measurements according to OIML recommendation IR-32/89, Annex A, with slight and heavy upstream perturbation. Therefore, this meter design fulfills the installation conditions according to technical guideline G 13, section 1. The PTB testing vol. 29 and 30, testing of volume gas meters with air at atmospheric pressure and high-pressure testing rules apply as a testing requirement. The RMG turbine meter TME 400 conforms to EN12261. The measuring accuracy in the range of $0.2 Q_{\max}$ to Q_{\max} is between $\pm 1.0 \%$ to 1.5% (see *chapter 1.4.2.10 Measuring accuracy*). The TME 400 has an electronic suppression by external shut-down of the totalizer of the slow down cutoff of the turbine wheel after the flow is stopped.

1.4.2.9 Measuring ranges

Type TME 400 turbine meters have measuring ranges of at least 1:20 at atmospheric pressure (see *chapter 1.4.2.10 Measuring accuracy*). At a higher pressure, the measuring range can be expanded to 1:50. The measuring ranges are between 2.5 and 25,000 m³/h (operating conditions), depending on meter size.

The turbine meters with nominal diameter of DN25 and DN40 can be used up to a maximum of 16 bar. However, there may be restrictions for threaded connections that are subsequently used.

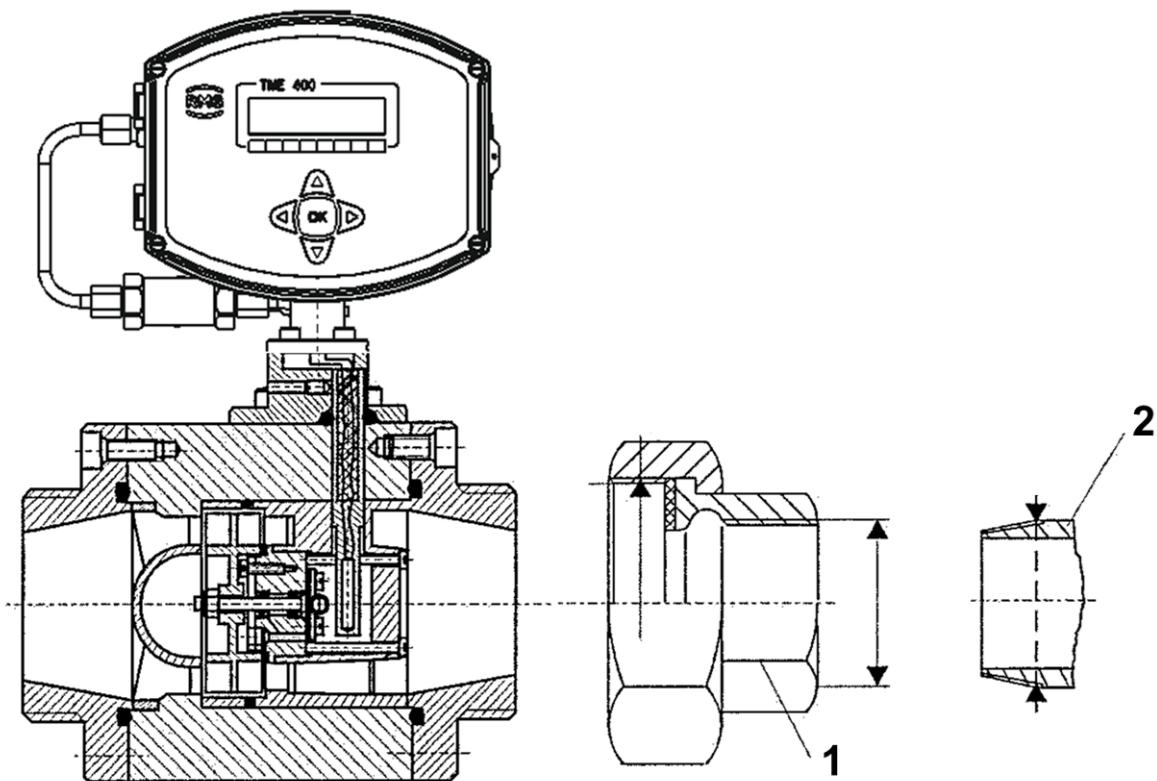

Figure 2: Threaded connection for DN25 and DN40

- 1 – Pipe fitting DIN2950
 - DN25 thread G 1 ½ ISO 228-1
 - DN40 thread G 2 ¼ ISO 228-1
 - DN25 / thread Rp 1 ISO 7-1
 - DN40 / thread Pp 1 ½ ISO 7-1

- 2 – Gas pipe
 - DN25 / thread R1 ISO 7-1
 - DN40 / thread R1 ½ ISO 7-1

According to DIN30690-1, the maximum operating pressure for non-flammable gases may not exceed 16 bar; for flammable gases, EN746-2 defines a maximum pressure of 5 bar for DN25 and 2 bar for DN40. Usually these pressure restrictions are specified on a plate on the pipe fittings.

1.4.2.10 Measuring accuracy

The following error limits apply within the permissible measuring range:

DN	Qmin [m ³ /h]	Qmax [m ³ /h]	MR	Measurement deviation in the range of	
				Qmin-0,2 x Qmax [%]	0,2 x Qmax-Qmax [%]
25	2.5	25	1:10	±6	±2
40	6	70	1:12	±6	±1.5
80	13	160	1:12	±3	±1.0
50	6	100	1:16	±3	±1.5
80	16	250	1:16	±3	±1.0
	25	400	1:16	±3	±1.0
100	25	400	1:16	±2	±1.0
	40	650	1:16	±2	±1.0
80	13	250	1:20	±3	±1.5
	20	400	1:20	±3	±1.5
100	20	400	1:20	±3	±1.5
	32	650	1:20	±3	±1.5

Note

With a slightly smaller measuring range of 1:16, turbine meters are also available in nominal diameters DN 80 and DN 100, which have an increased accuracy with a deviation of max. ±1% in the range of 0.2 x Q_{max}-Q_{max}.

DN	Qmin [m ³ /h]	Qmax [m ³ /h]	MR	Measurement deviation in the range of	
				Qmin-0,2 x Qmax [%]	0,2 x Qmax-Qmax [%]
150	32	650	1:20	±2	±1
	50	1000	1:20	±2	±1
	80	1600	1:20	±2	±1

200	80	1600	1:20	±2	±1
	125	2500	1:20	±2	±1
250	125	2500	1:20	±2	±1
	200	4000	1:20	±2	±1
300	200	4000	1:20	±2	±1
	325	6500	1:20	±2	±1
400	325	6500	1:20	±2	±1
	500	10000	1:20	±2	±1
500	500	10000	1:20	±2	±1
	800	16000	1:20	±2	±1
600	800	16000	1:20	±2	±1
	1250	25000	1:20	±2	±1

1.4.2.11 Pressure loss

The measuring parts for determining pressure loss are 1 x DN upstream and downstream of the meter. The pressure loss is calculated according to the following formula:

$$\Delta p = Z_p \cdot \rho \cdot \frac{Q_m^2}{DN^4}$$

where:	Δp	pressure loss	[mbar]
	Z_p	coefficient of pressure loss	[-]
	ρ	density	[kg/m ³]
	Q_m	volume flow rate at measurement conditions	[m ³ /h]
	DN	nominal diameter	[mm]

Device type	Z_p
Turbine meter TME 400	5040
Perforated plate straightener L1 according to ISO/DIN	3150
Perforated plate straightener L2 according to ISO/DIN	6300
Perforated plate straightener L3 according to ISO/DIN	9450
Perforated plate straightener LP-35 RMG standard	1260
Bend straightener RB 19 according to ISO/DIN	1260

The values for Z_p are rough averages. The exact value is calculated from the pressure loss, which is determined when testing the meter.

Example calculation for the pressure loss of a turbine meter:

TME 400 in DN 150:

$Q_m = 650 \text{ m}^3/\text{h}$

$\rho = 1.3 \text{ kg}/\text{m}^3$ (natural gas at 600 mbar overpressure)

$Z_p(\text{TME 400}) = 5040$ (see the table above)

Calculation:

$$\begin{aligned} \Rightarrow \Delta p &= 5040 \cdot 1,3 \cdot \frac{650^2}{150^4} \text{ mbar} \\ &= \underline{\underline{5.5 \text{ mbar}}} \end{aligned}$$

1.4.2.12 Putting the device into operation

Note

You receive the TME 400 parameterized and calibrated according to your specifications, so that no additional settings are generally required.

However, check whether these settings match your specifications; check the settings of the pulse width, the frequency reducer and the settings of the current output (for versions with current output).

Bring all totalizers to the meter status which you desire. (see *chapter 4.2 Programming*).

Note

Parameters can be changed exclusively with the device open.

1.4.2.13 Maintenance / lubrication

The TME 400 turbine gas meter is maintenance-free (apart from the lubrication for meters with an oil pump).

Meters in custody transfer operation must be calibrated at the prescribed intervals (according to national law). For meters in secondary operation, we recommend from a metrological point of view a check at the manufacturer every 5 to 8 years.

The TME 400 is equipped with permanently lubricated bearings up to a nominal diameter of DN150 as standard. Nominal diameters of DN200 or higher are provided with an integrated lubricating device. Optionally, the TME 400 can also be equipped with the "small oil pump" lubricating devices for DN25 to DN150 versions.

The type of lubricating device and the lubricant requirement depend on the nominal diameter and the pressure level:

Nominal diameter	Pressure classes	Lubricating device	Lubricant requirement
DN25-DN150	All pressure classes	As necessary (see below) optional small oil pump (push-button operated)	Every 3 months 6 strokes
DN200	All pressure classes	Small oil pump (push-button operated)	Every 3 months 6 strokes
DN250	PN10 to PN16 ANSI 150		
DN250	PN25 to PN100 ANSI300 to ANSI600	Large oil pump (lever operated)	Every 3 months 2 strokes
> DN300	All pressure classes		

Also observe the notice plate on the housing.

In unfavorable conditions, e.g. with an accumulation of water and hydrocarbon condensate, as well as dust-laden gases, more frequent lubrication is recommended, even daily in extreme cases (e.g. with continuous condensate formation).

Note

Recommended lubricating oil:

Shell Tellus S2 MA 10 or another oil with 2 to 4°E at 25°C.

2 Installation

2.1 Electrical connections

Open the cover of the meter in order to reach the electrical connections.



Figure 3: Unscrewing the screws to open the cover

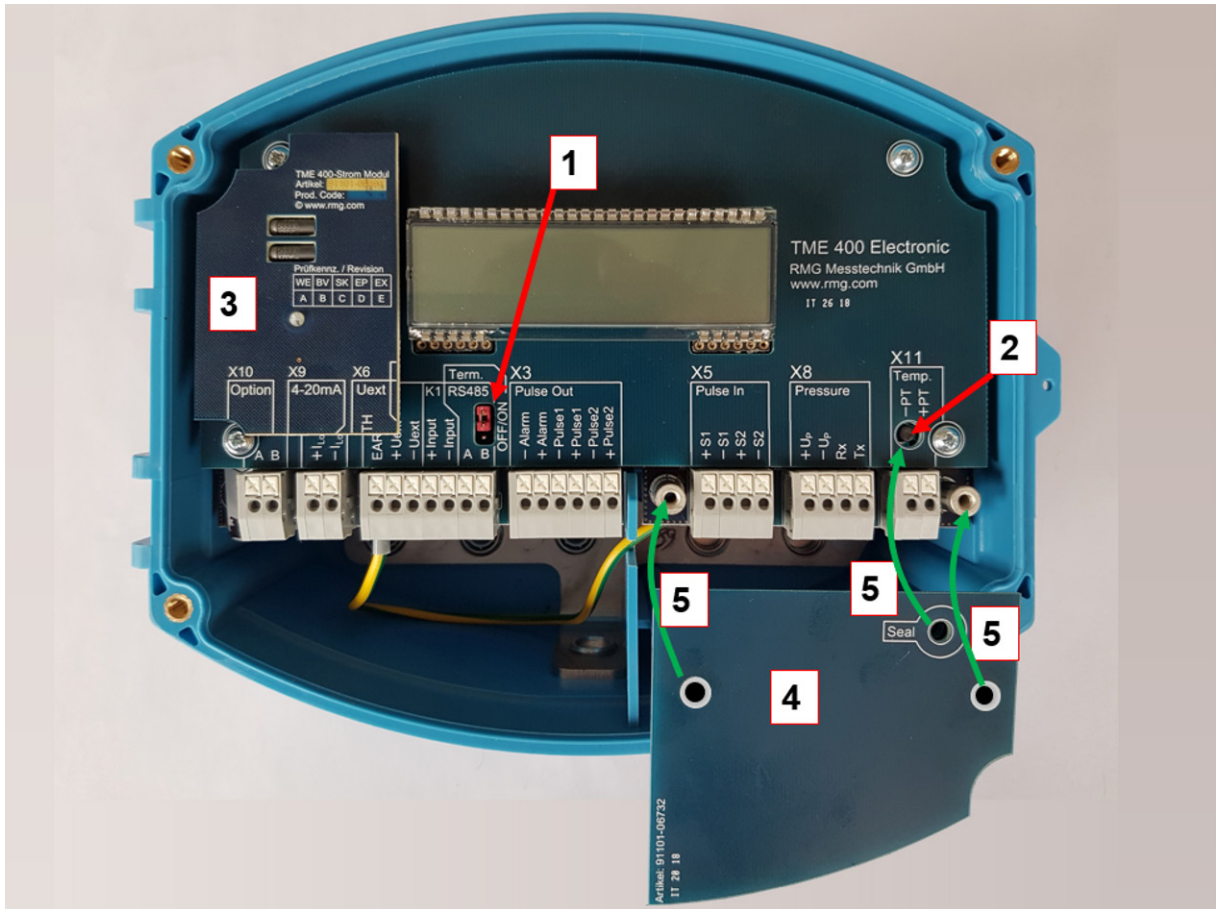

Figure 4: Electronics with cover of the calibration button

- 1 Jumper for RS 485 terminating resistor. Bridged: with 120 Ω ; open: $\infty \Omega$
- 2 Calibration switch
- 3 Current module board
- 4 Cover plate for pressure and temperature sensor and calibration switch
- 5 Normal position, indicated by green arrows

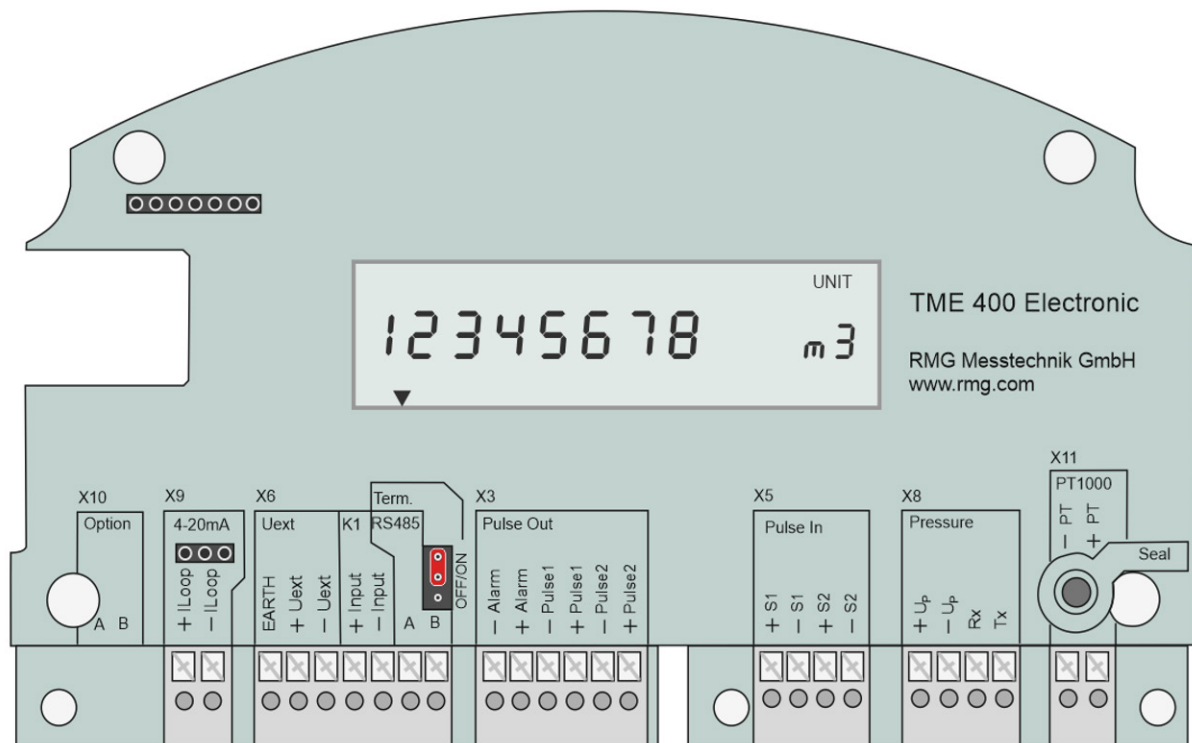

Figure 5: Connection assignment of the TME 400

However, assignments are possible; the pin assignments of the TME 400 are shown in in *Figure 5: Connection assignment of the TME 400*. If, for example, the TME 400 is to be used as a "flow sensor", the current must be connected to 4..20 mA (**terminal block X9**). The 4..20 mA current is then connected to the two terminals. For this function, the optional current module must be plugged in at the top left (see *Figure 4: Electronics with cover of the calibration button*).

The "sensor" TME 400 is passive, it is fed and limits the current to the corresponding value. With this use, the current serves as an additional current supply (see *chapter 1.3.4 Power supply*). Here, care must be taken to ensure that this power supply is galvanically isolated.

If digital communication with the TME 400 is required, it can be connected to the RS485. The differential signals are obtained via data lines A and B under RS485 (**terminal block X6**). Please pay attention to crossed signal lines and change the connections if appropriate. If necessary, the data interface can be conditioned using a jumper. Normally, the resistance is infinitely large ($\infty \Omega$); for a point-to-point connection or if the terminal device is part of a bus system, the resistance must be set to 120Ω .

Via "+ Uext" (external voltage supply, positive potential) and "- Uext" (external voltage supply, negative potential) the TME 400 can be fed with 6-30 VDC in addition to the internal battery (in non-Ex areas). "Earth" is used for internal voltage balance. The power supply can be independent or in combination with the RS485 interface. Anyhow, this supply voltage is required for communication via the RS485 interface.

Terminal block X6 also contains a digital input K1, which can be used to start, stop and reset the totalizer; "+Input" is the contact input for positive potential, "-Input" the contact input for negative potential.

⚠ Caution

In the Ex version, refer to the EC type approval certificate for the maximum values for the current output and the RS 485!

Via "Pulse In" (**terminal block X5**), pulses proportional to the flow rate at measurement conditions can be read from an encoder with 1 or 2 frequency outputs (main encoder and second redundant encoder if required).

Encoder (sensor) 1 is connected to the terminals via "+S1" (positive potential) and "-S1" (negative potential), encoder (sensor) 2 is connected to "+S2" and "-S2". This is especially necessary for the TME 400-VMF version operated at custody-transfer applications. The sensor types can be selected in coordinates Z26/27 (see chapter 4.3.3.7 Settings). Pulse input 2 is only active if a 2-channel counting mode is selected (coordinate Z25).

Via "Pulse Out2" (**terminal block X3**) pulses and redundant pulses can be output. An alarm output can also be connected here. These six terminals combine the three digital outputs:

- Alarm: Alarm output negative potential
- +Alarm: Alarm output positive potential

The alarm output works according to the closed-circuit current principle. The switching contact is closed in undisturbed condition.

2 Installation

-Pulse 1: HF output negative potential

+Pulse 1: HF output positive potential

At this output, the arriving pulses at pulse input 1 are synchronously with a pulse width of 1 ms.

-Pulse 2: LF output negative potential

+Pulse 2: LF output positive potential

Output pulses are output at these terminals depending on the change in the volume flow rate. The pulse output factor can be used to weight the number of output pulses in relation to the increase in volume.

For the device types TME 400-VC and TME 400-VCF, the dependence of the pulse output on the standard volume can also be selected (see coordinates A11 and A21). In coordinate A22 the possible pulse width can be 20ms, 125ms or 250ms.

A pressure sensor can be connected to the four connections of **terminal block X8**: "+Up" positive and "-Up" negative voltage supply for pressure sensor; "RX" or "TX" are the serial data received from the pressure sensor or sent to the pressure sensor.

The temperature sensor, a Pt1000, is connected to the terminals **of terminal block X11** in two-wire connection. Pressure and temperature sensors are generally only in use with the TME 400-VC and TME 400-VCF versions.

The terminals of the **terminal block X10** are connections for an optional module which is not yet supported by the firmware.

Use the wire end ferrules for the connecting cable and route them in from below; a seal holds the cable. To be able to pull a cable out again, press the small white square (marked with the X) down using a small screwdriver (at the bottom in *Figure 4: Electronics with cover of the calibration button* and *Figure 5: Connection assignment of the TME 400*; top of the plug strip) in order to open the locking device. Hold down the square and pull the cable out of the connector strip.

Some connection examples are given on the following pages. Anyhow, please check for further connections the data and limitations of the connected devices in the documentations of these devices.

Caution

**The TME 400 and connected devices do not have any plugs that have a to prevent polarity reversal.
Pay careful attention to the correct connections!**

Ex version
with modules Phoenix / Turck

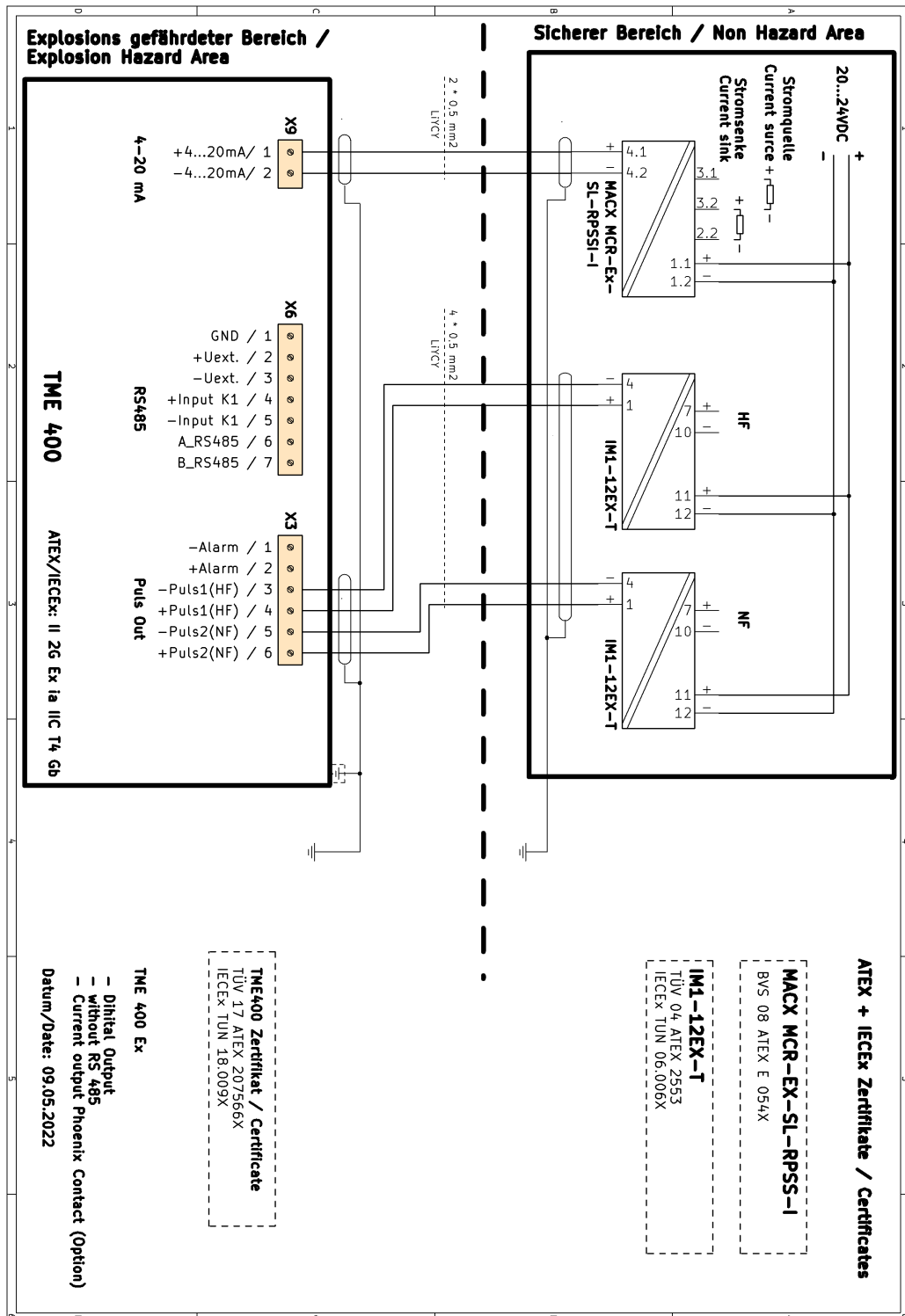

2 Installation

Ex version with modules Pepperl+Fuchs / Turck

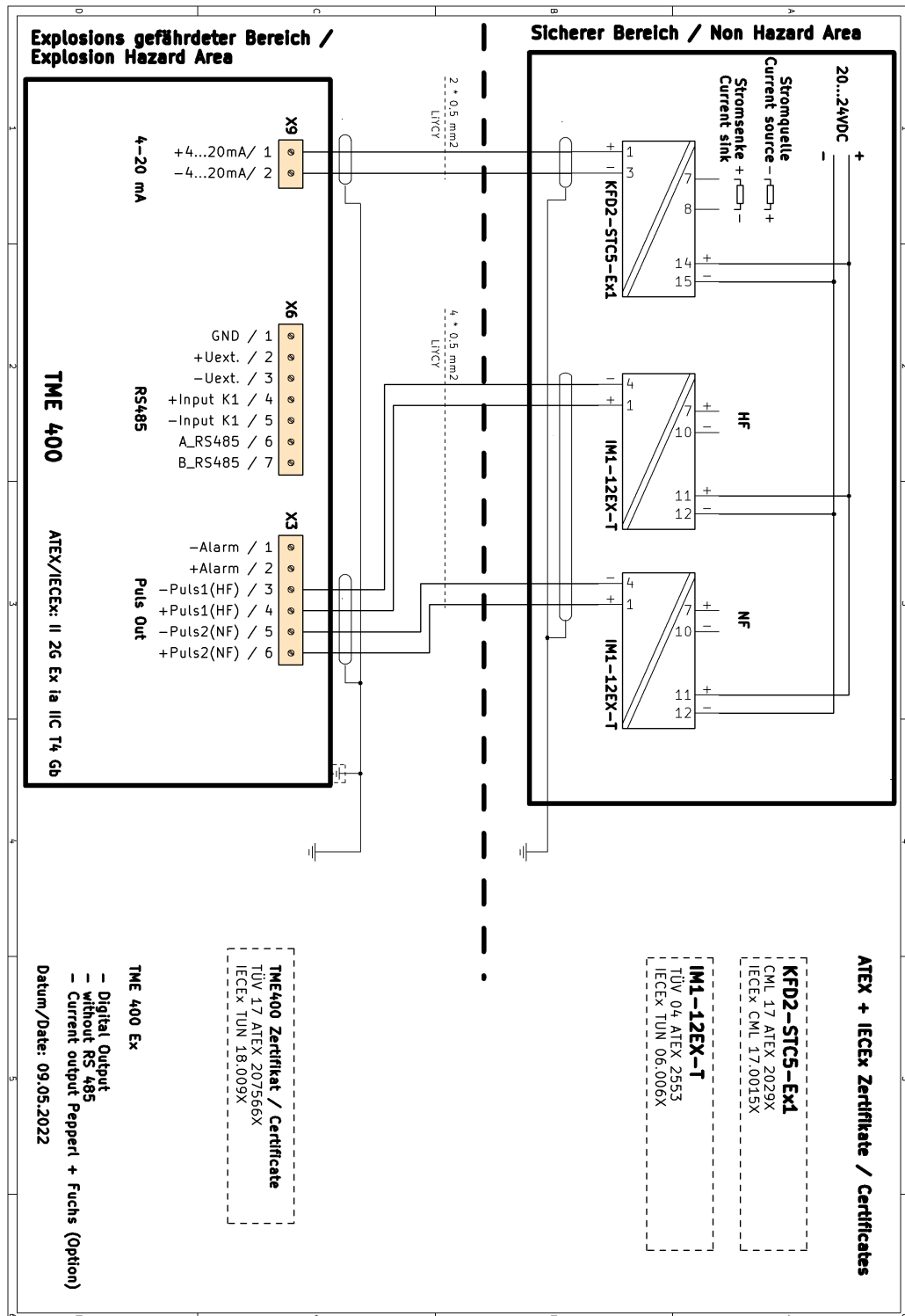

Ex version
with modules Phoenix / Omron / Datcom

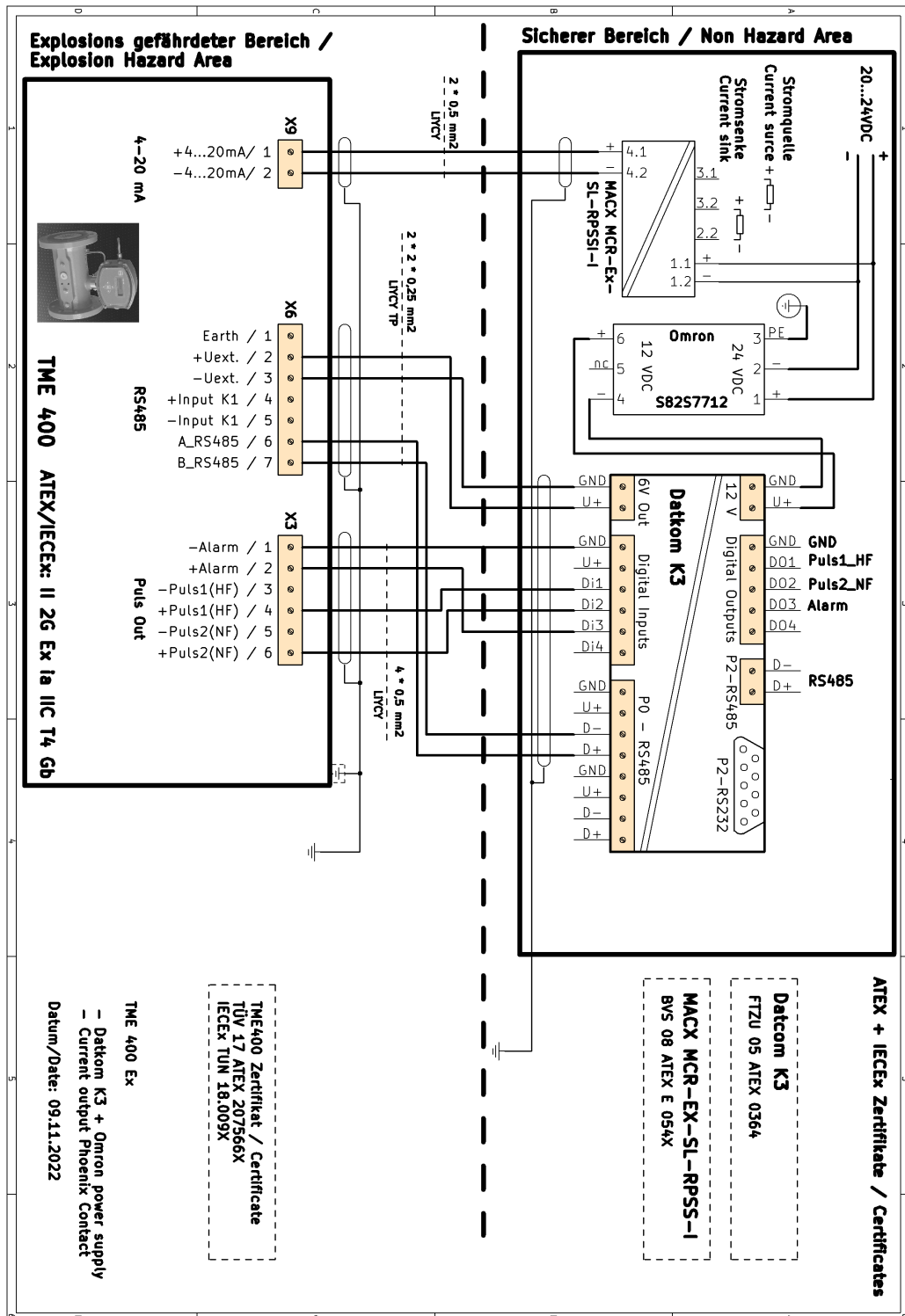

2 Installation

Ex version with modules Pepperl+Fuchs / Omron / Datcom

44

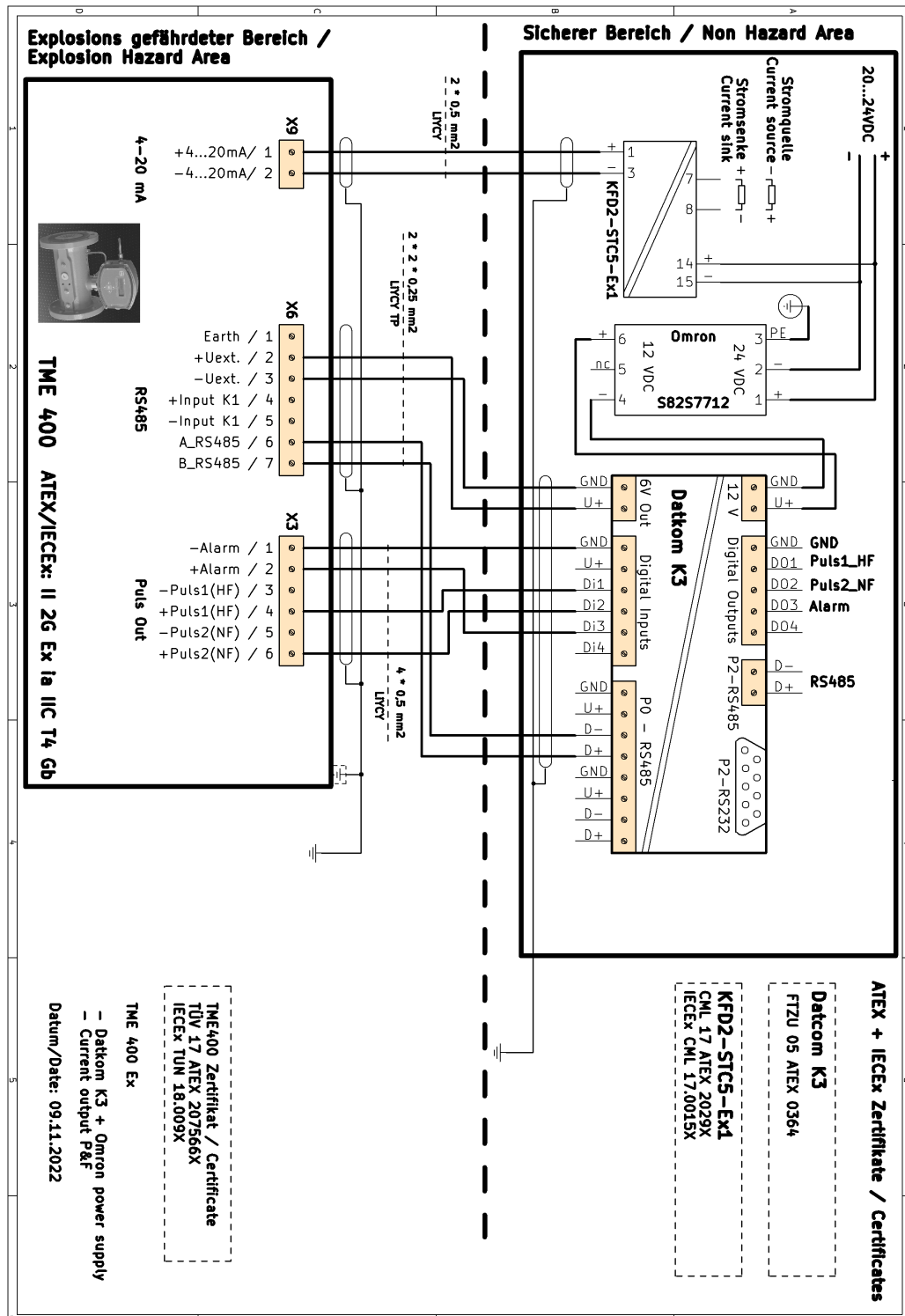

Ex version
with modules Phoenix / Meanwell / Datcom

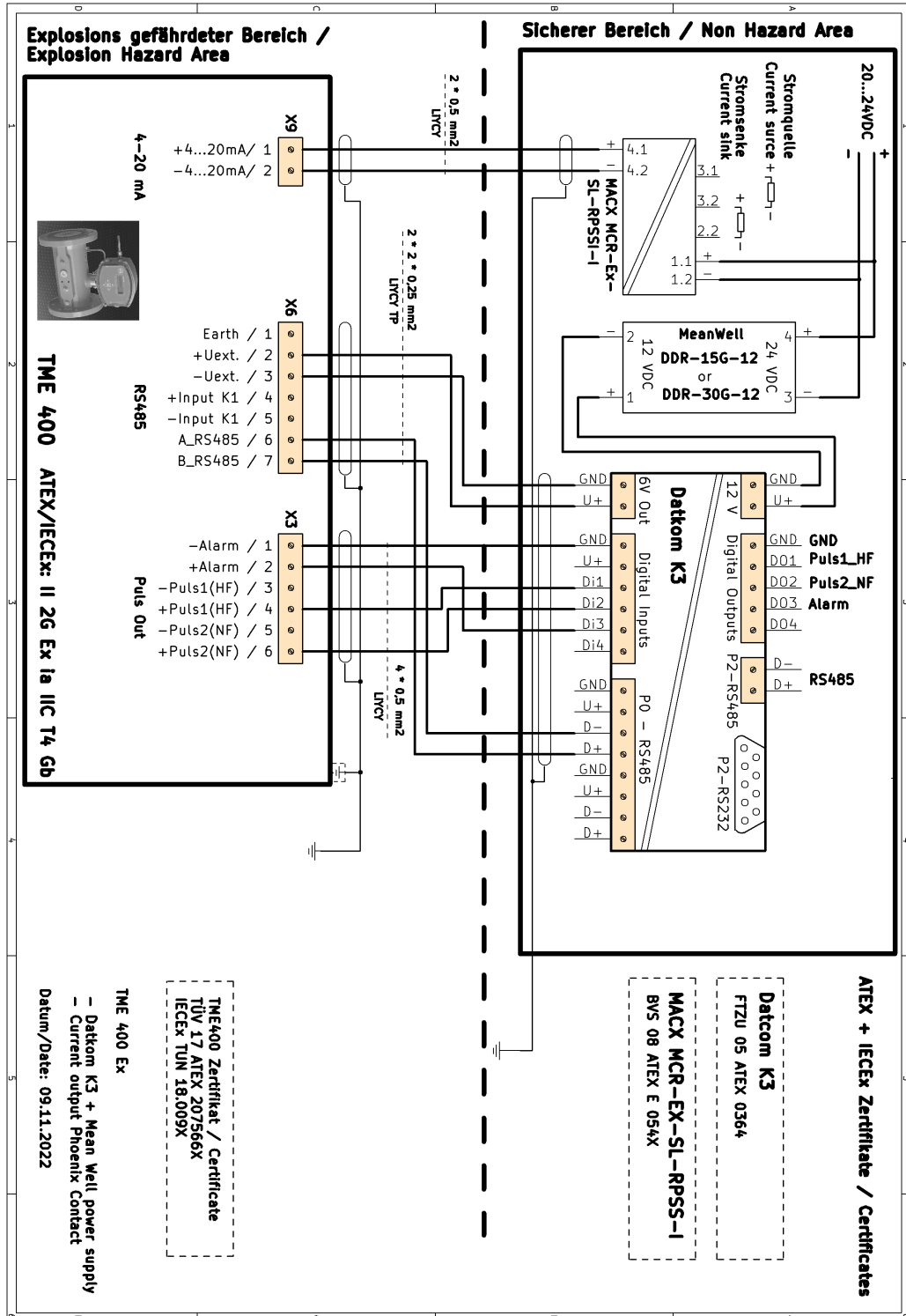

45

2 Installation

Ex version with modules Pepperl+Fuchs / Meanwell / Datcom

46

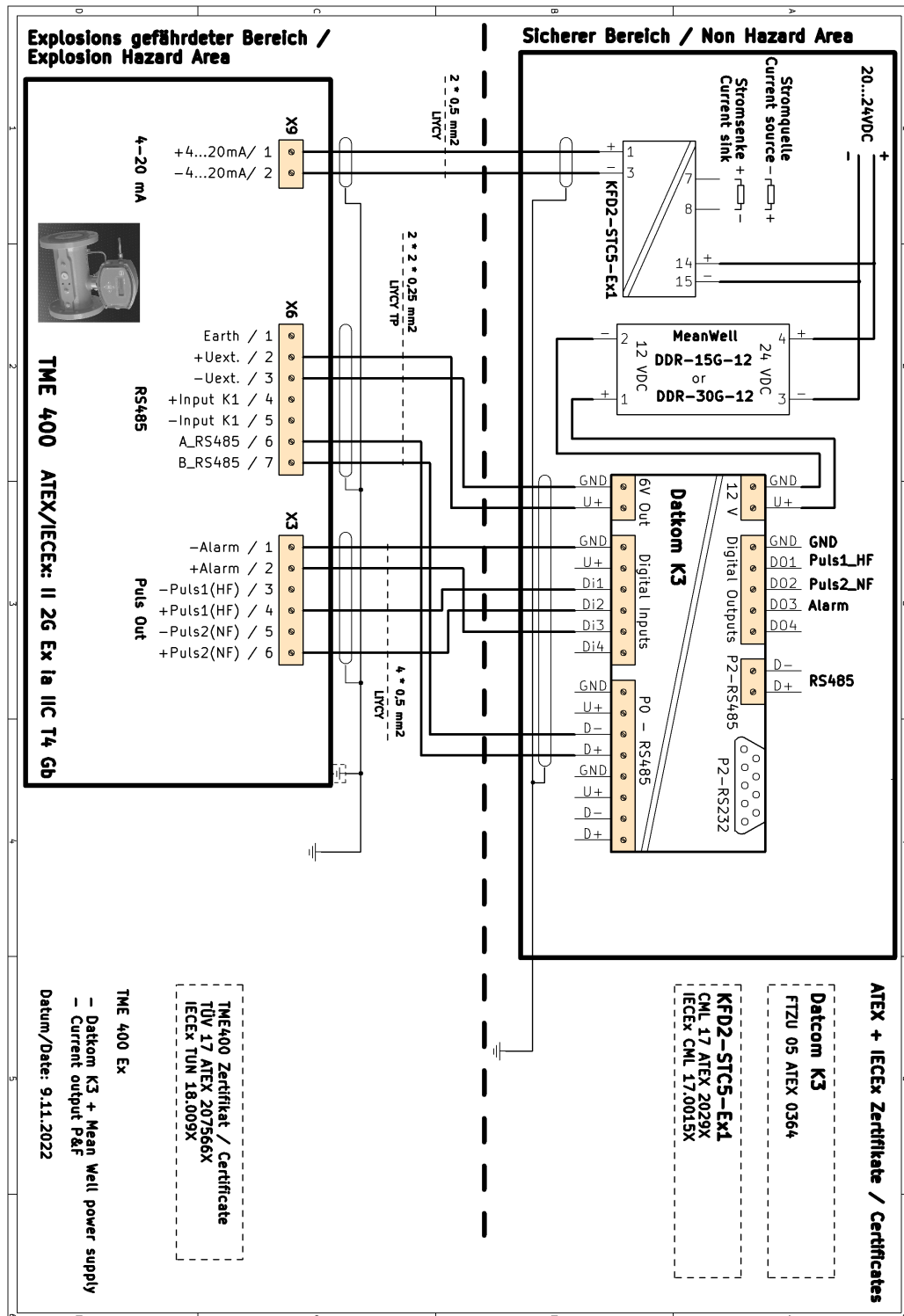

Ex version with module Ex 400

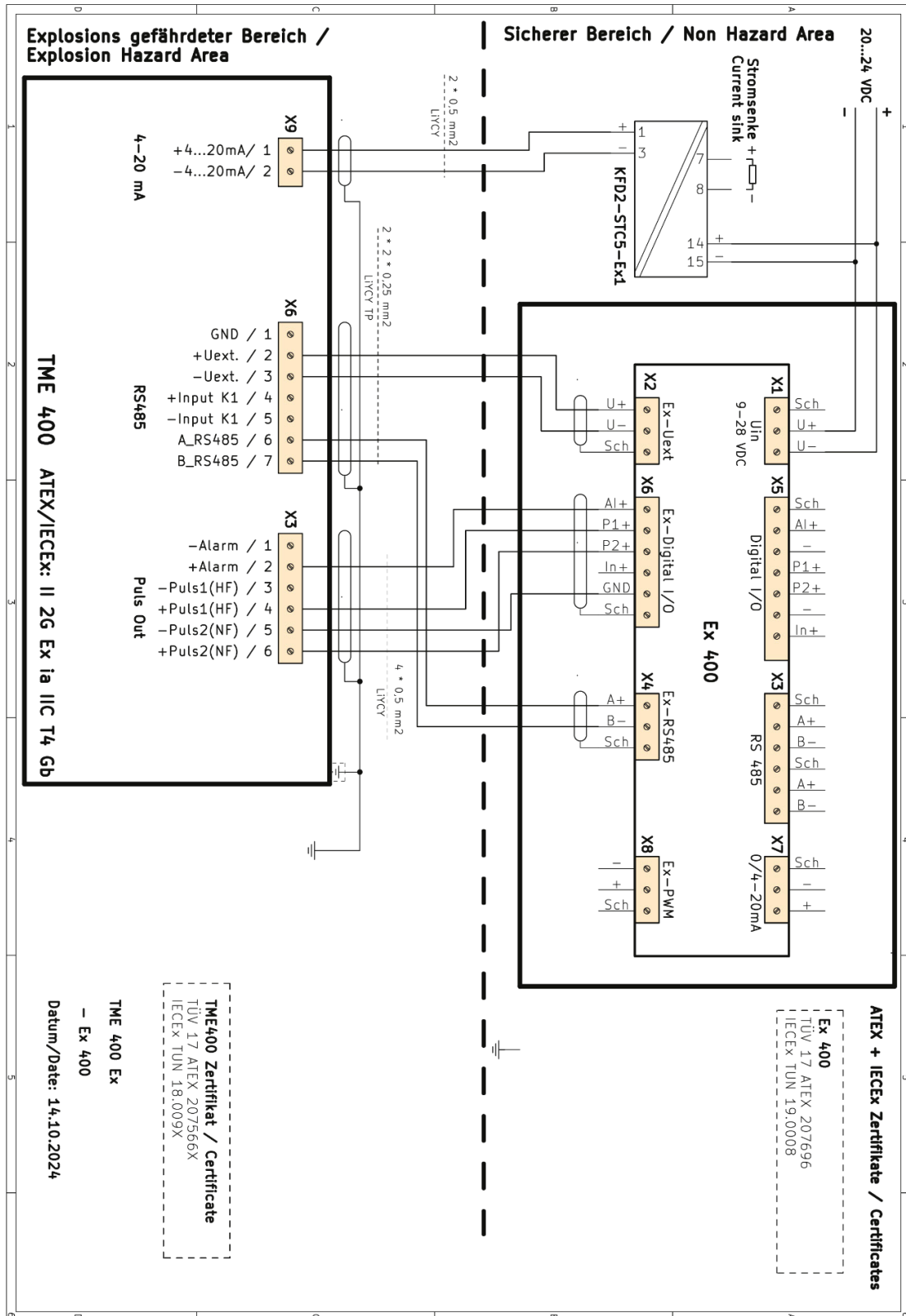

3 TME 400

3.1 Display field

A single-line alphanumeric display with 12 characters enables representation of the data and measurements together with the short description or the unit.

48

Total flow volume

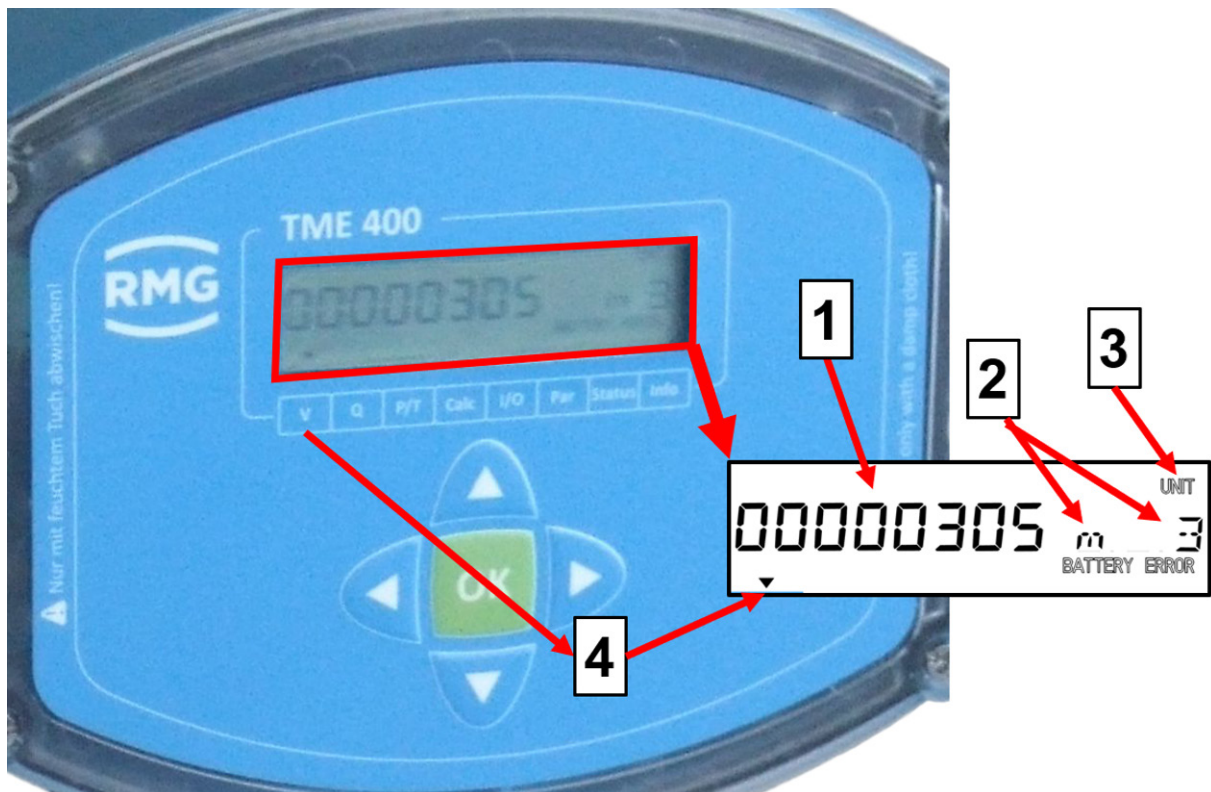

Figure 6: Display field

- | | | | |
|---|----------------------------|---|--------------------------|
| 1 | 8 characters for the value | 3 | Text: UNIT |
| 2 | Unit [m ³] | 4 | Display arrow for volume |

The LCD display and its operation are designed to save energy in order to enable battery-powered operation. The display can be impaired at temperatures below -25°C or above +60°C.

3.1.1 Display test

The display test is provided to ensure that all fields of the display function properly. For this purpose, please press and hold the up arrow and down arrow buttons (▲ and ▼) for more than 2 seconds. The following display appears while these buttons are held.

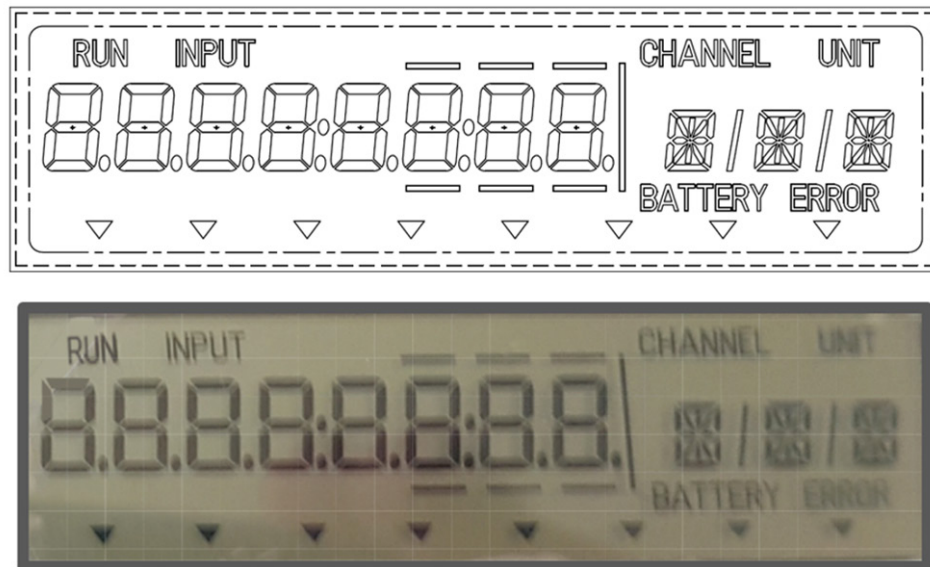

Figure 7: Display at display test

3.1.2 Reset

To reset the system, the voltage supply is interrupted and the TME 400 is switched off for this period. For this purpose, the battery and any existing external voltage supply are disconnected. The program and operating parameters are not lost in the process and the meter statuses are saved.

3.1.3 Booting up

It may be necessary to re-boot the device in case of severe faults.

⚠ Caution

It is necessary to remove the seals, particularly the seal over the calibration button in order to boot up (see *Figure 8: Position of the calibration button*).

The TME 400 must only be used for custody transfer with unbroken seal. Removal or damage to seals normally entails considerable expenses!

Re-application of seals must only be carried out by an officially recognized inspection authority or calibration officials!



Figure 8: Position of the calibration button

Note

**The current parameter settings and meter statuses are lost when re-booting!
They are reset to standard values.
Therefore, prior to booting up, read and store all parameters of the TME 400.**

51

Proceed as follows to re-boot:

- Switch off the devices
- Press the "left ◀" and "right ▶" buttons simultaneously
- Switch on the voltage again
- Then, the text "del All" appears in the display.
- Release the depressed buttons.
- Press the calibration button with a thin pencil or small screwdriver.
- Now the device is booted up and the display shows "Boot".
- Then, "done" appears in the display and the meter status of the main meter is displayed.

Then, re-transmit all device parameters to the TME 400 or enter the values from the test certificated.

Note

**The serial interface is set to 38400 Bps, 8N1, Modbus RTU after booting.
These are also the default values of RMGView^{TME}
(see *chapter 4.5 RMGViewTME*).**

3.1.4 Battery replacement

Note

The coordinate G24 (see *chapter 4.3.3.4 Error / type plate*) indicates the remaining battery capacity. If the remaining capacity falls below 10 %, a warning is generated.

52

In order to replace the battery, unscrew the large screw on the right side of the electronics with a large screwdriver or a coin.



Figure 9: Position of the battery housing

The meter is rotated in the next figure, showing the rear area in this figure below. Now, you can pull out the battery holder with battery on a handle.

The battery can be removed vertically in relation to the battery holder by pulling slightly. When installing the new battery, ensure that the polarity is retained for the new battery.

⚠ Danger

The battery must only be replaced in a non-explosive atmosphere. Ensure that the electronics are supplied with adequate ventilation with fresh air.

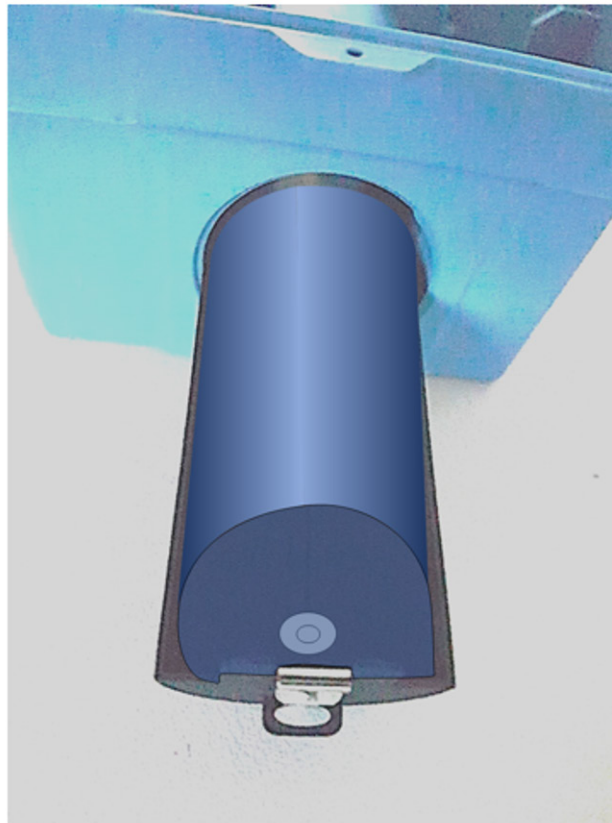

Figure 10: Battery holder

Note

The battery can be changed during operation.

- All readings of the counter(s) and all counting parameters are retained.
- After changing the battery, the current time and date must be entered again (coordinates X01 and X02; see *chapter 4.3.3.6 Archive*). In addition, the battery change must be indicated in coordinate G25. This updates the battery change date and sets the operating hours G26 to 0 and the battery capacity G24 to 100 %.

⚠ Danger

According to the type examination certificate, only the following battery types may be used in potentially explosive areas:

- Saft, type LS33600, 17 Ah or
- XENO, type XL 205-F, 19 Ah

54

Note

You can also have the battery replaced by the RMG Service department; please contact RMG for this purpose (see page 2).

Please only use the battery types intended by RMG. They are available as spare parts.

Also observe the information in the Disposal section on page 14.

4 Operation

4.1 Operation concept



Figure 11: Front panel

The concept of the operation is simple and easy to implement with knowledge of the coordinates.

4.1.1 Coordinate system

All configuration data, measurements and computed values are sorted in a table in a coordinate system which enables easy access. The coordinate system is divided into several columns, as shown on, in part, on the front panel (see *top* and *bottom*).



Figure 12: 8 columns of the coordinate system

Note

With the TME 400-VM and TME 400-VMF turbine meters, the p/T and Calc. columns cannot be selected.

56

With the cursor buttons (arrows)



you can reach each value by gently pressing the desired button in this coordinate system.

Keypad	Description	Effect
	Left arrow	Switches the column of the table from right to left
	Up arrow	Upward movement within the column of the table: You move from the last value of the list towards the first value. This is also used to adjust numbers (counting up).
	Down arrow	Downward movement within the column of the table: You move from the first value of the list towards the last value. This is used to adjust numbers (counting down).
	Right arrow	Switches the column of the table from left to right
	Function	The following functions are triggered by pressing: pressed < 2 seconds = display of the coordinate pressed > 2 seconds = switch to settings mode (see below)

4.1.2 Display and coordinate system

The main meter is displayed in normal operating mode. The other display values can be selected with the operating buttons. After approx. 1 minute, the TME 400 switches back to the main meter.

If the display is dark, the TME 400 is in energy-saving mode, where the display is completely switched off. The incoming pulses are processed, and the outputs are actuated.

The display value is shown again by pressing any operating button.

Any arbitrary position in the coordinate system, which is identified by letters and numbers, can be reached with the arrow keys.

	A	B	C	D	E	F	G	H	X	Y	Z
01											
02						F02					
03											
04											
05											
06											
07											
...											

Example:

F02 Current mode. The current output can be configured here.

4.1.3 Parameter protection

Note

All custody-transfer parameters are protected by the (sealed) calibration button.

There are different access authorizations for the parameters with which unauthorized changes are suppressed. The different access rights are assigned to the coordinates by a letter. They are shown in the coordinate list. The following access levels are used:

Access level	Access right
A	Display values, change not possible
N	Parameter for which no password is necessary for use
C	Code word Entry of a code word is necessary to change the parameter.
E	Calibration button Custody-transfer variant TME 400-VMF: Custody-transfer display values / parameters, use of the calibration button is necessary. Non-custody-transfer variant TME 400-VM: Entry of the code word is adequate.

Note

Enabling or disabling the code word or opening the calibration button creates an entry in the event archive (see below).

4.2 Programming

There are five buttons available on the front foil for programming of the TME 400. Alternatively, you can carry out programming via the RMGView^{TME} operating software (see *chapter 4.5 RMGViewTME*).

4.2.1 Programming with the programming buttons

Basically, you proceed as follows for the programming:

- First check the protection status of the coordinate. When parameters are not protected, you can carry out changes, as described below without additional measures.
- With parameters protected by code word, you must enter it first in coordinate Z15. Please read how to make the entry as below.
- With parameters protected for custody-transfer applications, you must press the calibration button first.







Caution







It is necessary to remove the seals, particularly the seal over the calibration button in order to press the calibration button (see *Figure 8: Position of the calibration button*).

The TME 400 must only be used for custody transfer with unbroken seal. Removal or damage to seals normally entails considerable expenses!

Re-application of seals must only be carried out by an officially recognized inspection authority or calibration officials!

The principle of the programming is shown based on the example of changing the output pulse factor:

- I. Move with the arrows (   ) to the position: A11
- II. Activate the calibration button (see *Figure 8: Position of the calibration button*)
- III. The blinking "INPUT" text appears above the displayed value in the display view.
- IV. Press **OK** for more than 2 seconds
- V. The value begins to blink at a position
- VI. With the  and  arrows, you can now increase or decrease the value at this position. For the values, after the "0", you also have "-1" available in order to enter negative values, if necessary.

- VII. With the  and  arrows, you can move to a different position of the value and change it – as described in the point above.
- VIII. An additional position is added when you move with the  and  before the displayed number.
For example, only the units digit is displayed. If you move in front of it, you will also have the tens position available as an entry.
- IX. By pressing and holding the "right" button , the position of the decimal point is changed. After pressing and holding, the decimal point is inserted after the blinking digit.
- X. By pressing and holding the "left" button , the entry can be canceled. If a change and/or entry is necessary, the entry must be restarted.
- XI. When you have finished making an entry, you confirm it by briefly pressing **OK**.
- XII. A plausibility check takes place and the result is displayed immediately.
- XIII. If this check shows an implausible entry, "rAnGE" will be shown briefly in the display and the display jumps back to the original value.
- XIV. If this check shows a plausible entry, "Good" will be shown briefly in the display and the value is adopted as a new value.
- XV. Now you can – if necessary – change other parameters.
- XVI. After about 1 minute without additional entries, the display returns to the display of the main meter.
- XVII. By pressing the calibration, you close the further entry of custody-transfer parameters.
- XVIII. After another minute without an entry, the change possibility is closed automatically.

Note



Some of the coordinates permit other settings as purely numerical values. However, these other entries are assigned numbers so that the adjustment can be carried out as described.

Example: Current mode F02 can be deactivated or activated on various settings. This is adjusted as follows:

0	Off (default)
1	No errors
2	Error 3.5 mA
3	Error 21.8 mA
4	0 - 20mA

If F02 = "0" is selected for the coordinate, the current output is switched off.

Note

With some coordinates, a number is assigned fixed values. Instead of an adjustment with 0, 1, ..., these numerical values are shown directly. Changes are possible with the arrows  and , then the next higher or lower value is shown and can be adopted with **OK**.

61

Example:

Digital output 2 pulse width (coordinate A22) can adjust the pulse width to 3 different widths. The following values can be directly as an assignment:

20 ms

125 ms

250 ms

4.3 Equations in the TME 400

The TME 400 enables calculation of different values from the measured data and in the data entered in the TME 400. For a better understanding, some variables and formula in this chapter are presented in advance; other equations and definitions of parameters are found in the *chapter 4.3.3. Coordinates in context*.

4.3.1 Variable description

Formula symbol	Units	Name
q_m	m ³ /h	Operating volume flow at measurement condition
f_V	Hz	Frequency of the volume transmitter
K_V	l/ m ³	Meter factor
V_m	m ³	Operating volume flow rate at measurement condition
P_V	Nondimensional (1)	Volume pulse
K_{Z1}	m ³ /l	Meter factor (only for output contacts)
K_{Z2}	m ³ /l	Meter factor (only for output contacts)

4.3.2 Standard formula

Variables presented from the previous chapter can be used for the basic equation for the volume flow at measurement conditions:

$$V_m = \frac{P_V}{K_V} \frac{1}{K_{Z1}}$$

$$\left(\text{Volume flow at measurement conditions} = \frac{\text{Number of pulses}}{\text{Meter factor} \times \text{Totalizer factor}} \right)$$

4.3.3 Coordinates in context

In the following, the coordinates which can be addressed with the TME 400-VM and TME 400-VMF turbine meters are shown. In the tables, the parameters which can be addressed with the TME 400-VM are shown in light blue and the values which are **additionally** available with the version for custody-transfer applications, TME 400-VMF, are shown in orange.

TME 400-VM	Non-custody-transfer applications
TME 400-VMF	Custody-transfer applications

4.3.3.1 Volume / Meters

Coordinate	Name	Description
A02	Operating volume	Volumes added up at current (temperature and pressure) conditions.
A05	Uncorrected operating volume	Z26: If the characteristic correction is deactivated, A05 is not visible and cannot be adjusted. If a characteristic correction is activated, this characteristic curve correction is deactivated from 0 up to this value A05.
A06	Volume Start/Stop	Starts and stops a volume flow measurement
A07	Volume Reset	Sets the volume flow rate to 0
A10	Meter factor	<p>With the meter factor (pulse value), the corresponding operating value flow is calculated from the signal frequency of the sensor element in the meter electronics.</p> $q_m = \frac{f_V}{K_V} * 3600 \left[\frac{m^3}{h} \right]$ <p>The meter factor must be calibrated at the factory so that a direct meter display in cubic meters.</p> <div style="border: 1px solid black; padding: 5px; margin: 10px 0;"> <p>Note</p> <p>A change of this adjustment takes place in the responsibility of the operator.</p> </div> <p>After any change to the meter factor, calculation takes place with the new value immediately.</p> <p>The uninfluenced signal frequency of the sensor element is available at the HF output. The frequency range can be determined from the meter factor K and the minimum and maximum operating volume flow of the meter according to the formula:</p> $f_{V \min} = \frac{q_{m \min}}{3600} * K_V \quad f_{V \max} = \frac{q_{m \max}}{3600} * K_V$ <p><i>q_{m min}</i>: minimum operating volume flow <i>q_{m max}</i>: maximum operating volume flow</p> <p>Example:</p> $q_{m \min} = 16 \text{ m}^3/\text{h}$ $q_{m \max} = 250 \text{ m}^3/\text{h}$ $K_V = 2362 \text{ pulses}/\text{m}^3$

		$f_{V \min} = \frac{16 \text{ m}^3}{3600 \text{ s}} \cdot 2362 \frac{\text{Impulse}}{\text{m}^3} = 10,5 \text{ Hz}$ $f_{V \max} = \frac{250 \text{ m}^3}{3600 \text{ s}} \cdot 2362 \frac{\text{Impulse}}{\text{m}^3} = 164 \text{ Hz}$ <p>If measuring channel-1 or -2 fails, the HF output is switched off. The remaining pulse input is used for further conversion and counting into the disturbed volume counters. (With firmware versions older than 1.11 the High-Frequency (HF) output is switched off if measuring channel-1 fails.)</p>										
A11	Output pulse factor	The output pulse value indicates how many LF output pulses correspond to one m ³ (1 m ³).										
A20	Display factor	<p>A20: Display factor for meters, including decimal places</p> <table border="1"> <tr> <td>0.01</td> <td>(i.e. display with 2 decimal places)</td> </tr> <tr> <td>0.1</td> <td>(i.e. display with 1 decimal place)</td> </tr> <tr> <td>1</td> <td>(default) (display without decimal places)</td> </tr> <tr> <td>10</td> <td>(display without decimal places)</td> </tr> <tr> <td>100</td> <td>(display without decimal places)</td> </tr> </table> <p>Example: If the factor is adjusted to 0.1, the meter status is displayed with one decimal place.</p> <div style="border: 2px solid black; padding: 5px;"> <p>Note</p> <p>If the factor is adjusted, for instance, to 10, the display value is displayed without a decimal place. You get the <u>actual</u> meter status by multiplying the display value by 10. This setting is marked with a "x 10" sticker (or it must be marked).</p> </div>	0.01	(i.e. display with 2 decimal places)	0.1	(i.e. display with 1 decimal place)	1	(default) (display without decimal places)	10	(display without decimal places)	100	(display without decimal places)
0.01	(i.e. display with 2 decimal places)											
0.1	(i.e. display with 1 decimal place)											
1	(default) (display without decimal places)											
10	(display without decimal places)											
100	(display without decimal places)											
A22	Digital output 2 pulse width	<table border="1"> <tr> <td>20 ms</td> </tr> <tr> <td>125 ms (default)</td> </tr> <tr> <td>250 ms</td> </tr> </table>	20 ms	125 ms (default)	250 ms							
20 ms												
125 ms (default)												
250 ms												
A12	Meter factor corrected	The meter can be adjusted by the operator, e.g. during calibration. This value does not change.										

Coordinate	Name	Modbus register	Modbus access	Protection	Data type	Min.	Max.	Default	Unit
A02	Operating volume	302	W	E	uint32	0	99999999	0	m ³
A05	Uncorrected operating volume	308	W	E	uint32	0	99999999	0	m ³
A06	Volume Start/Stop	310	W	N	uint32	0	99999999	0	m ³
A07	Volume Reset	312	W	N	uint32	0	99999999	0	m ³
A10	Meter factor	500	W	E	string12	*	*	1000.0	l/m ³
A11	Output pulse factor	506	W	E	float	0.01	100	1.0	l/m ³
A20	Display factor	510	W	E	menu16	0	4	2	
A22	Digital output 2 pulse width	512	W	N	menu16	0	2	1	ms
A12	Meter factor corrected	508	R	A	float	-	-	1.0	l/m ³

65

4.3.3.2 Flow rate

Coordinate	Name	Description
B02	Operating flow rate	Flow rate under current operating conditions
B03	Frequency	Unchanged output value, frequency of Sensor 1.
B05	Min. flow rate	an alarm is generated below this flow rate
B06	Max. flow rate	an alarm is generated above this flow rate
B10, B11, B12, B13; B14;	Coefficients: A-2, A-1, A0, A1, A2	Z26: If the characteristic correction is deactivated, the additional parameters are not visible and cannot be adjusted. If a characteristic correction is activated (see Z26 below), a correction takes place with the factors in: B10: Factor for the characteristic correction B11: Factor for the characteristic correction B12: Factor for the characteristic correction B13: Factor for the characteristic correction B14: Factor for the characteristic correction
B15	Max. operating point deviation	B15: If the deviation of the corrected from the uncorrected characteristic at an operating point (or a range) is more than the adjusted value (2% here), the correction, is set to "0" for this operating point or operating range, which means a correction takes place.
B08	Leak flow volume limit	The flow rate is disregarded below this leak flow volume limit - i.e. it is set to 0
B09	Maximum time > Q _{ug} +	Indicates the maximum time until the flow rate (e.g. on start-up) reaches the measuring range (Q _{min}) after reaching the lower measuring limit (Q _{ug}). The flow rate measurement applies as defective during this time, but no error message is generated.

Coordinate	Name	Modbus register	Modbus access	Protection	Data type	Min.	Max.	Default	Unit
B02	Operating flow rate	320	R	A	float	-	-	*	m ³ /h
B03	Frequency	322	R	A	float	-	-	*	Hz
B05	Min. flow rate	521	W	E	float	*	*	0.0	m ³ /h
B06	Max. flow rate	523	W	E	float	*	*	1000.0	m ³ /h
B10	Coefficient A-2	530	W	E	float	*	*	0	Am2
B11	Coefficient A-1	532	W	E	float	*	*	0	Am1
B12	Coefficient A0	534	W	E	float	*	*	0	A0
B13	Coefficient A1	536	W	E	float	*	*	0	A1x10 ⁻⁴
B14	Coefficient A2	538	W	E	float	*	*	0	A2x10 ⁻⁸
B15	Max. operating point deviation	540	W	E	float	0.0	100.0	2.0	kkp
B08	Leak flow volume limit	527	W	E	float	*	*	*	m ³ /h
B09	Maximum time > Qug +	529	W	E	uint16	0	10000	10	s

4.3.3.3 Current output

Coordinate	Name	Description										
F01	Current	Current to be output										
F02	Current mode	<table border="1"> <tr> <td>0</td> <td>Off (default)</td> </tr> <tr> <td>1</td> <td>No errors</td> </tr> <tr> <td>2</td> <td>Error 3.5 mA</td> </tr> <tr> <td>3</td> <td>Error 21.8 mA</td> </tr> <tr> <td>4</td> <td>0 - 20mA</td> </tr> </table> <p>If the current mode is "0", meaning "Off", in apart from parameter F02: current mode, no additional parameters of the output are visible or adjustable.</p>	0	Off (default)	1	No errors	2	Error 3.5 mA	3	Error 21.8 mA	4	0 - 20mA
0	Off (default)											
1	No errors											
2	Error 3.5 mA											
3	Error 21.8 mA											
4	0 - 20mA											
F03	Current source	<table border="1"> <tr> <td>0</td> <td>Specification (default)</td> </tr> <tr> <td>1</td> <td>Operating flow rate</td> </tr> <tr> <td>2</td> <td>Frequency</td> </tr> <tr> <td>3</td> <td>Calibration 4mA</td> </tr> <tr> <td>4</td> <td>Calibration 20mA</td> </tr> </table>	0	Specification (default)	1	Operating flow rate	2	Frequency	3	Calibration 4mA	4	Calibration 20mA
0	Specification (default)											
1	Operating flow rate											
2	Frequency											
3	Calibration 4mA											
4	Calibration 20mA											
F04	Phys. minimum value	Current output phys. minimum (required for display in RMGView ^{TME})										
F05	Phys. maximum value	Current output phys. maximum (required for display in RMGView ^{TME})										
F06	Current specification	Specification value for the current output (for testing purposes)										
F07	Current moderation	The current output is damped by averaging. A value of 0 corresponds to no damping. A value of 0.98 causes strong averaging.										

Coordinate	Name	Description
F10	Calibration value 4mA	Calibration: Current value 4mA (after activation of current source)
F11	Calibration value 20mA	Calibration: Current value 20mA (after activation of current source)
F12	Module serial number	Serial number of the current module

Coordinate	Name	Modbus register	Modbus access	Protection	Data type	Min.	Max.	Default	Unit
F01	Current	330	R	A	float	-	-	-	mA
F02	Current mode	657	W	N	menü16	0	4	0	
F03	Current source	658	W	N	menü16	0	7	0	
F04	Figure below	659	W	N	float	-	-	0.0	
F05	Picture above	661	W	N	float	-	-	1000.0	
F06	Current specification	663	W	N	float	0.0	25.0	12.0	mA
F07	Current moderation	665	W	N	float	0.0	0.98	0.7	I-D
F10	Calibration value 4mA	667	W	N	float	0.0	25.0	4.0	mA
F11	Calibration value 20mA	669	W	N	float	0.0	25.0	20.0	mA
F12	Module serial number	671	W	N	string8	-	-	0000 0000	SN

4.3.3.4 Error / type plate

Coordinate	Name	Description				
G01	Current error	Identifies the current error				
G02	Software version	Shows the version number of the firmware in the TME 400.				
G04	Serial number electronics	Serial number of the TME 400 electronics				
G05	Firmware checksum	Shows the checksum of the firmware (important for TME 400-VMF and TME 400-VCF in custody-transfer applications)				
G06	Measuring point	Possibility of numerical identification for the measuring point				
G18	Meter number	Number of the turbine meter				
G21	CRC metrological Param. EEPROM	CRC of metrological parameters EEPROM				
G23	Date of Battery Exchange	Date of battery exchange				
G24	Remaining Battery Capacity	Remaining capacity of the battery				
G25	Battery Change	<table border="1"> <tr> <td>0</td> <td>No (default)</td> </tr> <tr> <td>1</td> <td>Yes</td> </tr> </table>	0	No (default)	1	Yes
0	No (default)					
1	Yes					
G26	Operating Hours	Operating hours				

Coordinate	Name	Description
G19	Meter size	Meter size (G ..)
G20	Date of last battery replacement	Shows the date of the last battery replacement

68

Coordinate	Name	Modbus register	Modbus access	Protection	Data type	Min.	Max.	Default	Unit
G01	Current error	675	R	A	uint16	-	-	0	ERR
G02	Software version	676	R	A	float	-	-	*	Rev
G04	Serial number electronics	680	W	E	int32	0	99999999	0l	SNo
G05	Firmware checksum	682	R	A	int16	-	-	*	CRC
G06	Measuring point	314	W	A	uint32	*	*	0	Rev
G18	Meter number	699	W	E	int32	*	*	9999 9999	MNo
G21	CRC metrological Param. EEprom	804	R	A	string8	-	-	CALC	Hex
G23	Date of Battery Exchange	705	W	C	string8	-	-	010117	Bat
G24	Remaining Battery Capacity	790	R	A	uint16	-	-	100	%
G25	Battery Change	791	W	C	menu16	0	1	0	-
G26	Operating Hours	792	R	A	uint32	-	-	0	h
G19	Meter size	701	W	E	string8	*	*	4-16000	G
G20	Date of last battery replacement	705	W	C	int32	*	*	0101 2014	Bat

4.3.3.5 RS-485 interface

Coordinate	Name	Description
H01	RS-485 Baud rate	2400 Bps
		9600 Bps
		19200 Bps
		38400 Bps (default)
H02	RS-485 parameter	0 8N1 (default)
		1 8E1
		2 8O1
		3 7N1
		4 7E1
		5 7O1

Coordinate	Name	Description
H03	RS-485 protocol	0 Off
		1 Modbus RTU (default)
		2 Modbus ASCII
H04	Modbus ID	Modbus device address (default = 1).
H05	Modbus register offset	The offset is defined as 1 by RMG.

Coordinate	Name	Modbus register	Modbus access	Protection	Data type	Min.	Max.	Default	Unit
H01	RS-485 Baud rate	709	W	N	menu16	0	3	3	Bps
H02	RS-485 parameter	710	W	N	menu16	0	5	0	
H03	RS-485 protocol	711	W	N	menu16	0	2	1	
H04	Modbus ID	712	W	N	uint16	1	250	1	MID
H05	Modbus register offset	713	W	N	uint16	0	10000	1	Mof

4.3.3.6 Archive

Coordinate	Name	Description
X01	Time	Direct entry of the current time as described above.
X02	Date	Direct entry of the current date as described above.
X10	Delete parameter archive	0 No (default)
		1 Yes
X11	Parameter archive fill level	Display value
X14	Delete event archive	0 No (default)
		1 Yes
X15	Event archive fill level	Display value

70

Coordinate	Name	Description	
X16, X17, X18, X19, X20, X21, X22, X23	Measurement archive mode	0 Off	
		1 On (default)	
		If measurement archive mode is activated, the following archives are visible and can be adjusted and deleted as necessary.	
		Minutes archive	
		X17 interval	0 15 minutes (default)
			1 30 minutes
			2 60 minutes
		X18 delete	0 No (default)
			1 Yes
		X19 fill level	Display value
		Day archive	
		X20 delete	0 No (default)
			1 Yes
		X21 fill level	Display value
Month archive			
X22 delete	0 No (default)		
	1 Yes		
X23 fill level	Display value		
X24	Delete all Archives	All archives	
		X24 delete 0 No (default)	
		1 Yes	
X12	Delete parameter archive (E)	0 No (default)	
		1 Yes	
X13	Parameter archive (E) fill level	Display value	

Coordinate	Name	Modbus register	Modbus access	Protection	Data type	Min.	Max.	Default	Unit
X01	Time	712	W	E	string8				T
X02	Date	717	W	E	string8				D
X10	Delete parameter archive	722	W	E	menu16	0	1	0	
X11	Parameter archive fill level	723	R	A	uint16	-	-	0	%
X14	Delete event archive	726	W	E	menu16	0	1	0	

Coordinate	Name	Modbus register	Modbus access	Protection	Data type	Min.	Max.	Default	Unit
X15	Event archive fill level	727	R	A	uint16	-	-	0	%
X16	Measurement archive mode	728	W	E	menu16	0	1	1	
X17	Minute archive interval	729	W	E	menu16	0	2	0	
X18	Delete minute archive	730	W	E	menu16	0	1	0	
X19	Minute archive fill level	731	R	A	uint16	-	-	0	%
X20	Delete day archive	732	W	E	menu16	0	1	0	
X21	Day archive fill level	733	R	A	uint16	-	-	0	%
X22	Delete month archive	734	W	E	menu16	0	1	0	
X23	Month archive fill level	735	R	A	uint16	-	-	0	%
X24	Delete all archives	812	W	E	menu16	0	1	0	
X12	Delete parameter archive (E)	724	W	E	menu16	0	1	0	
X13	Parameter archive (E) fill level	725	R	A	uint16	-	-	0	%

Further information about archives are in the *Appendix B Structure of the archives*.

4.3.3.7 Settings

Coordinate	Name	Description
Z04	X:Y maximum pulse error	A differential circuit compares the metered pulse of measuring and comparison channels alternately. Every deviation is counted internally. An alarm is generated if the adjusted limit value is exceeded. The failure counter is reset to 0 for each new measurement or after the maximum number of pulses (Z05) is reached.
Z05	X:Y maximum pulse	see above
Z10	Error register 1	Display value
Z11	Error register 2	Display value
Z12	Status register 1	Display value
Z13	Status register 2	Display value

Coordinate	Name	Description																		
Z15	Code word release	<div style="border: 2px solid black; padding: 5px;"> <p>Note</p> <p>The code word for the TME 400 is: 1 2 3 4</p> <p>This is always displayed as " **** " in the parameter archive.</p> </div> <p>With entry of this code word, the protected parameters can be changed.</p>																		
Z16	Change code word	A new password can be defined here.																		
Z17	Device type	<table border="1"> <tr><td>0</td><td>TME 400-VM (default)</td></tr> <tr><td>1</td><td>TME 400-VC</td></tr> <tr><td>2</td><td>TME 400-VMF (MID)</td></tr> <tr><td>3</td><td>TME 400-VCF (MID)</td></tr> </table>	0	TME 400-VM (default)	1	TME 400-VC	2	TME 400-VMF (MID)	3	TME 400-VCF (MID)										
0	TME 400-VM (default)																			
1	TME 400-VC																			
2	TME 400-VMF (MID)																			
3	TME 400-VCF (MID)																			
Z24	Display active max.	<table border="1"> <tr><td>0</td><td>1 minute (default)</td></tr> <tr><td>1</td><td>5 minutes</td></tr> <tr><td>2</td><td>60 minute test</td></tr> </table> <p>The time during which the display is active for tests is selected as 60 minutes. In general, however, it must be observed that higher energy consumption is associated with this time, so this time should be selected as short as possible, if possible.</p>	0	1 minute (default)	1	5 minutes	2	60 minute test												
0	1 minute (default)																			
1	5 minutes																			
2	60 minute test																			
Z25	Volume metering mode	<table border="1"> <tr><td>0</td><td>1-channel without errors (default)</td></tr> <tr><td>1</td><td>1-channel stop on error</td></tr> <tr><td>2</td><td>1-channel run on error</td></tr> <tr><td>3</td><td>1-channel start / stop</td></tr> <tr><td>4</td><td>1-channel reset</td></tr> <tr><td>5</td><td>2-channel stop on error</td></tr> <tr><td>6</td><td>2-channel run on error</td></tr> <tr><td>7</td><td>2-channel without X:Y error</td></tr> <tr><td>8</td><td>1 Channel Start/Stop Mode 2</td></tr> </table> <p>With 1-channel measurements (0, 1, 2, 3, 4), the Z04 and Z05 pulse comparison is not activated. An entry for sensor type 2 is superfluous and has no further significance.</p> <p>Volume metering mode 8: 1 Channel Start/Stop Mode 2 If the external contact input 3 is closed (or opened), this additional mode 2 triggers a start (or stop) for the start/stop totalizer during this time. The LF output and the current output are deactivated for this period (4 mA) and no pulses are output (main totalizers stop). In case of an error, the pulses are counted in the error totalizers and current and pulses are output.</p>	0	1-channel without errors (default)	1	1-channel stop on error	2	1-channel run on error	3	1-channel start / stop	4	1-channel reset	5	2-channel stop on error	6	2-channel run on error	7	2-channel without X:Y error	8	1 Channel Start/Stop Mode 2
0	1-channel without errors (default)																			
1	1-channel stop on error																			
2	1-channel run on error																			
3	1-channel start / stop																			
4	1-channel reset																			
5	2-channel stop on error																			
6	2-channel run on error																			
7	2-channel without X:Y error																			
8	1 Channel Start/Stop Mode 2																			

Coordinate	Name	Description						
Z26	Characteristic correction	<p>If the TME 400 is supplied with a current supply, the TME 400 enables a characteristic correction via a polynomial. This correction must be activated with coordinate Z26. With this polynomial correction, the corresponding percentage deviations of the turbine meter from a reference standard are determined for fixed percentage flow rate values. From these deviations, a polynomial function which ideally reflects the curve running through these points is calculated. The coefficients of the polynomial A-2, A-1, A0, A1 and A2 are adjusted by the manufacturer in the coordinates B10 to B14 or can be entered there when the manufacturer of the turbine meter provides these values.</p> <div style="border: 1px solid black; padding: 5px; margin-top: 10px;"> <p>Note</p> <p>The HF output pulses (X3 pulse 1) are always uncorrected! With an active characteristic curve correction, no HF pulses are output.</p> </div> <table border="1" style="margin-top: 10px; width: 100%;"> <tr> <td>0</td> <td>Off (default)</td> </tr> <tr> <td>1</td> <td>On</td> </tr> </table>	0	Off (default)	1	On		
0	Off (default)							
1	On							
Z27	Sensor type 1	<table border="1" style="width: 100%;"> <tr> <td>0</td> <td>Reed sensor</td> </tr> <tr> <td>1</td> <td>Wiegand sensor (default)</td> </tr> <tr> <td>2</td> <td>External</td> </tr> </table>	0	Reed sensor	1	Wiegand sensor (default)	2	External
0	Reed sensor							
1	Wiegand sensor (default)							
2	External							
Z28	Sensor type 2	<p>Settings are possible, but only make sense in 2-channel operation. Settings changed here have no effect in 1-channel operation,</p> <table border="1" style="width: 100%;"> <tr> <td>0</td> <td>Reed sensor</td> </tr> <tr> <td>1</td> <td>Wiegand sensor (default)</td> </tr> <tr> <td>2</td> <td>External</td> </tr> </table>	0	Reed sensor	1	Wiegand sensor (default)	2	External
0	Reed sensor							
1	Wiegand sensor (default)							
2	External							
Z29	Volume unit	<table border="1" style="width: 100%;"> <tr> <td>0</td> <td>m³ (Default)</td> </tr> <tr> <td>1</td> <td>cf</td> </tr> </table>	0	m ³ (Default)	1	cf		
0	m ³ (Default)							
1	cf							

Coordinate	Name	Modbus register	Modbus access	Protection	Data type	Min.	Max.	Default	Unit
Z04	X:Y maximum pulse error	775	W	E	uint16	1	10000	10	X
Z05	X:Y maximum pulse	776	W	E	uint16	1	10000	10000	Y
Z10	Error register 1	332	R	A	int16	-	-	*	Err
Z11	Error register 2	333	R	A	int16	-	-	*	Err
Z12	Status register 1	334	R	A	int16	-	-	*	Sta
Z13	Status register 2	335	R	A	int16	-	-	*	Sta

Coordinate	Name	Modbus register	Modbus access	Protection	Data type	Min.	Max.	Default	Unit
Z15	Code word release	777	W	N	uint16	1	9999	0	COD
Z16	Change code word	778	W	C	int16	1	9999	1234	C-V
Z17	Device type	779	W	E	menu16	0	3	0	
Z24	Display active max.	780	W	N	menu16	0	2	0	
Z25	Volume metering mode	781	W	E	menu16	0	8	0	
Z26	Characteristic correction	782	W	E	menu16	0	1	0	
Z27	Sensor type 1	783	W	E	menu16	0	2	1	
Z28	Sensor type 2	784	W	E	menu16	0	2	1	
Z29	Volume unit	785	W	E	menu16	0	1	0	

Note

If the parameter is not dimensioned, the text in the "Unit" column is shown in the display of the TME 400 to the right under UNIT.

4.4 Special settings

4.4.1 Configuration of the current output

The connection of external devices to the current output of the meter is to be carried out as described in chapter 2.1 *Electrical connections*.

The parameters are then set in column 'F Current output' of the coordinate matrix as follows:

75

1. In coordinate **F-02** (current mode) select the operating mode of the current output:
 - 0: Off (default)
 - 1: 4-20mA - current is always calculated from the physical value
 - 2: 4-20mA - below the minimum value output of 3.5 mA
 - 3: 4-20mA - above the maximum value output of 21.8 mA.
 - 4: 0-20mA
2. In coordinate **F-03** (current source) select the value for output:
 - 0: Fixed value (default)
 - 1: Operating flow rate
 - 2: Sensor frequency
 - 3: Fixed value of 4mA for calibration
 - 4: Fixed value of 20mA for calibration
3. In coordinate **F-04** (physical minimum) enter the lower limit for the physical value at which 0 or 4 mA should be output.
4. In coordinate **F-05** (physical maximum) enter the upper limit for the physical value eintragen, at which 20 mA should be output.
5. In **F-06** (current specification) a fixed value can be entered for the current which is output with the entry 0 in coordinate F-02.
6. In **F-07** (damping) the inertia of the output can be set with values from 0 (minimum) to 0.99 (maximum).

4.5 RMGViewTME

The RMGView^{TME} software also provides an additional possibility of parameter input. This software offers you additional options in combination with the TME 400.

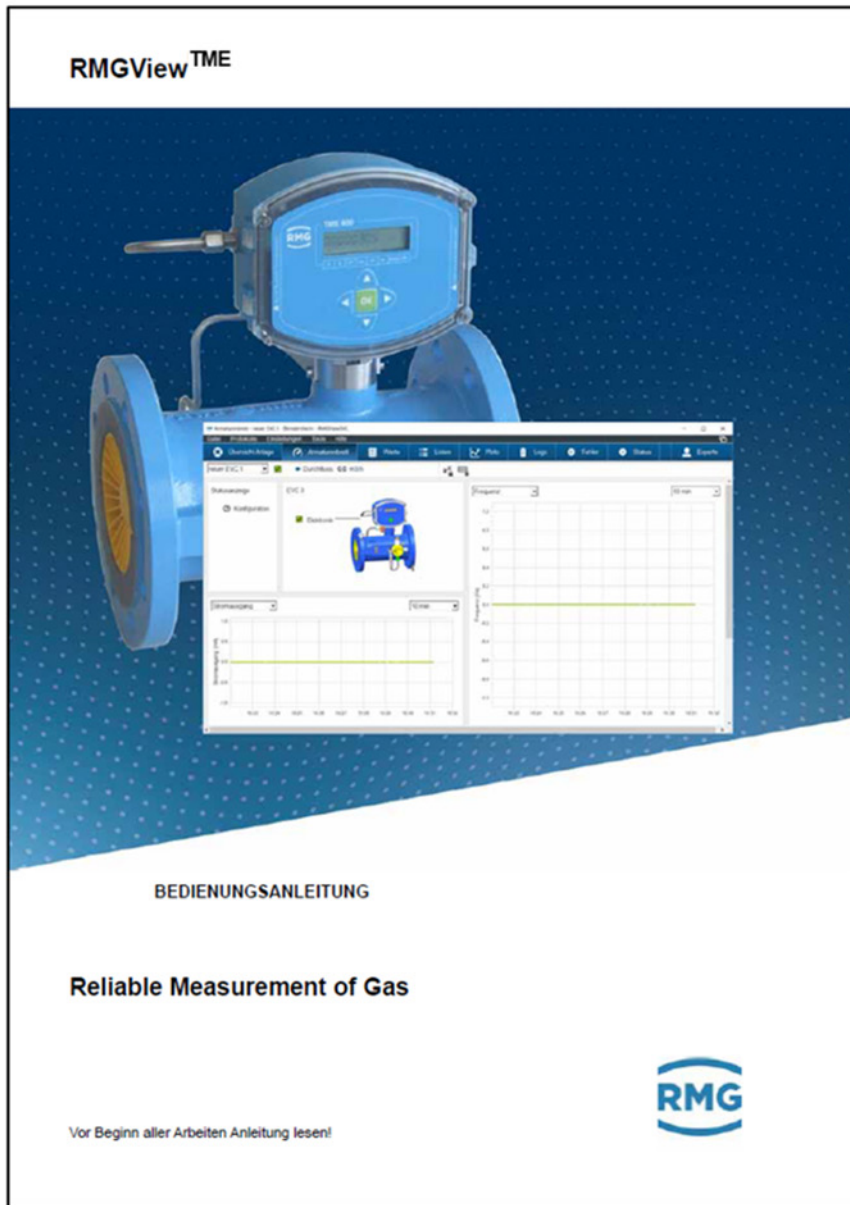

Figure 13: RMGView^{TME} software

5 Technical data

5.1 Device types

Reed or transistor (with connected turbine meter)	
Pulse input	Reed or transistor
Current output	Current loop connection (current supply via this current output possible)
Wiegand (with connected turbine meter)	
Use	Direct installation on the TME 400 turbine meter instead of the meter head
Pulse input	Wiegand
Current output	Current loop connection (current supply via this current output possible)

77

5.2 Inputs

Volume	
Reed	
Pulse frequency	0 Hz ... 4 Hz
Pulse width	≥ 20 ms
Voltage	low: ≤ 0.9 V high: ≥ 2.2 V
Wiegand	
Pulse frequency	0 Hz ... 400 Hz; with battery operation
Pulse width	≥ 5 μs
Voltage	min. 1 V max. 5 V (determined by sensor)

5.2.1 Power supply

Power supply	
Internal battery	Lithium cell 3.6 V; in the device (battery pack)
External 6-24 V DC via X6	via U _{ext} + battery pack (NON-Ex)
External 6-10.5 V DC via X6	via U _{ext} + battery pack (Ex)
External 6-24 V DC via X9	via current loop connection + battery pack

5.2.2 Pulse In measuring inputs (sensor 1 / 2)

Note

For Ex connection values, see approval.

78

5.3 Outputs

Non-Ex	
U_{min}	5 V
$U_{max} (U_i)$	30 V
I_{max}	100 mA

For use of the TME 400 in hazardous areas the values for the HF, LF and alarm output must be taken from the ATEX certificate.

5.4 Data interface

RS-485 data interface	
U_{ext}	6.0 – 24 V

For use of the TME 400 in hazardous areas the values must be taken from the ATEX certificate.

Note

When using the RS485 interface, the device must be supplied with power via U_{ext} .

Note

In an Ex version, the connection must only be made to a certified, intrinsic safe current circuit.

The Ex-relevant connection values are specified in the approval.

5.5 Current loop connection

Current loop connection	
Uext (min)	12 V
Uext (max)	28 V
Imin	3.5 mA
I _{max}	23 mA
External resistance (max.)	See: <i>Figure 14: Load depending on feeder supply</i>
Current output for	
- minimum flow rate	4 mA
- maximum flow rate	20 mA
- alarm	3.5 mA or 21.8 mA
Current output accuracy better than 1% of the end value	

Bürde in Abhängigkeit Geberspeisung
Load depending on feeder supply

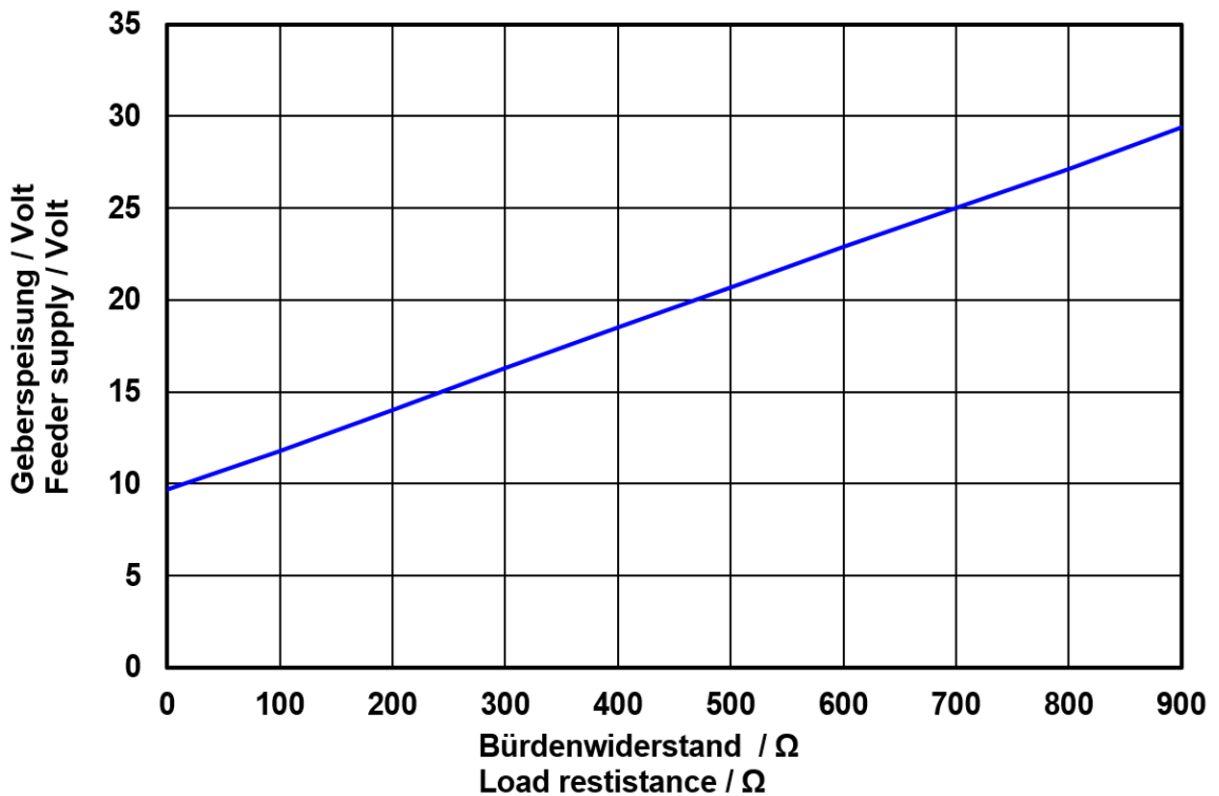

Figure 14: Load depending on feeder supply

For use of the TME 400 in hazardous areas the values must be taken from the ATEX certificate.

5.6 Cable

80

Signal cables (LF output, HF output, current loop connection, control input) must have 2 or more wires twisted in pairs and shielded (LiYCY-TP).

4-wire, twisted and shielded cables (LiYCY-TP) must be used for the data cables (RS-485).

The shielding must be grounded on both ends - on the TME 400, as described in the *section 5.7 Cable connection*.

Cable cross-sections of 0.5 mm² are recommended. Due to the cable screw connection, the outer diameter of the cable must be between 4.5 and 6.5 mm.

Caution

The maximum cable length is limited when used in hazardous areas due to the limit values for intrinsically safe current circuits and depending on the inductivity and capacity of the cable.

5.7 Cable connection

Connect the shield on both ends to the cable screw connections on the outside of the housing, as shown in the figure below:

- Unscrew the union nut.
- Pull the terminal insert out of the plastic.
- Slide the cable end through the union nut and the terminal insert and bend the shielding back.
- Plug the terminal insert back into the connecting piece.
- Tighten the union nut.
- Every Ex signal circuit must be routed with a dedicated cable which must be guided through the appropriate PG screw coupling.

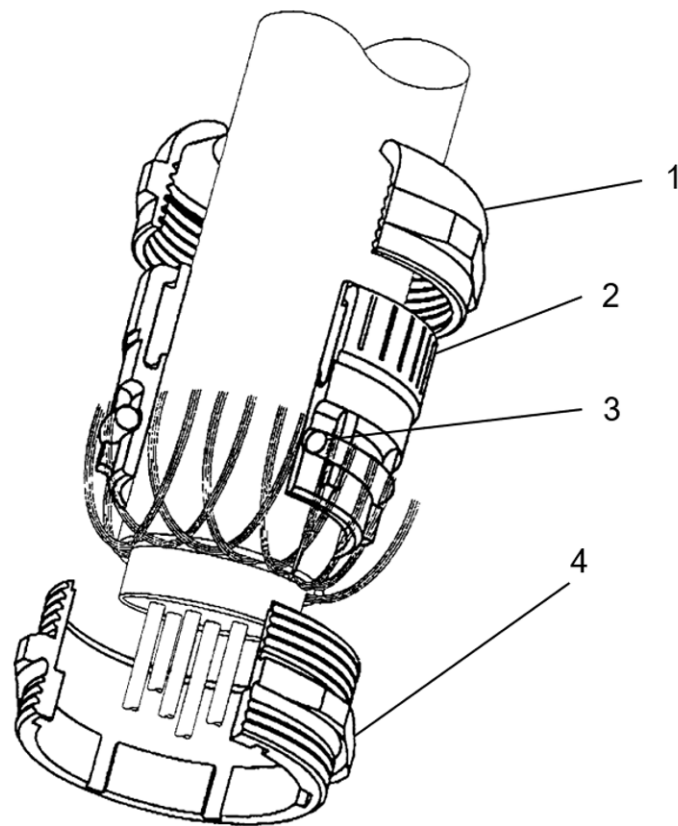

81

Figure 15: Terminal screw connection

- | | | | |
|---|-----------------|---|------------------|
| 1 | Coupling nut | 3 | O-ring |
| 2 | Terminal insert | 4 | Connecting piece |

5.8 Ground

Note

To avoid measuring errors due to electromagnetic interference, the meter housing must be grounded with the ground connection on the right section of the housing (see *Figure 16: Grounding the meter*).

Minimum cable cross-section:

- length of up to 10 m: 6 mm²
- length of 10 m or higher: 10 mm²



Figure 16: Grounding the meter

In the process, a conductive connection between the TME 400 and the pipeline must be provided as shown in the figure below.

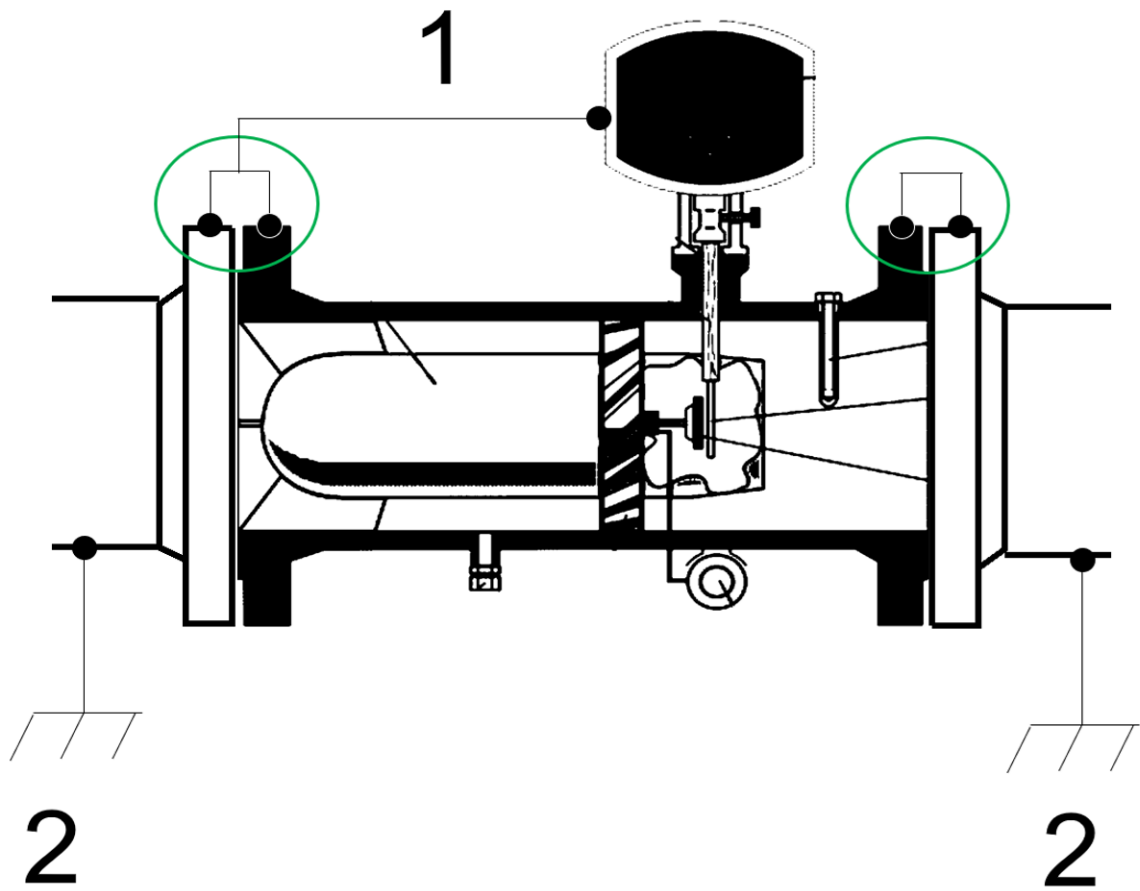

83

Figure 17: Grounding with the connecting pipes

- 1 Equipotential bonding conductor (PE) min. 6 mm²
- 2 Measuring system potential

5.9 Isolating amplifier type Ex-400

General data	
Supply voltage	9 – 28 V DC
Current consumption	340 mA
Power	1 W
Top-hat rail enclosure dimensions (L x W x H) [mm]	150 x 110 x 50
Gewicht	200 g
Protection class	IP 20 (Top-hat rail module) IP 65 (Wall-mounted in a closed housing)
Ambient temperature	-40 °C ... +60 °C
Mounting	on 35 mm-Top-hat rail or optional wall-mounted housing
Connection	0,25 ... 1 mm ² (Wire end ferrule with plastic collar)
EU-type examination certificate	TÜV 17 ATEX 207696
Ex marking	 II (2) G [Ex ia Gb] IIC
IECEEx marking	IECEEx TUN 19.0008
Input data (intrinsically safe ia)	
Connection side	Intrinsically safe supply of the gas meter
Intrinsically safe supply X2	
Number	1
U _o	10,7 V
I _o	122 mA
P _o	325 mW
C _o	750 nF
L _o	1 mH
Intrinsically safe switch inputs X6	
Number switch inputs	3
Input signals	floating switch contacts, resistor-wired switching contacts
Frequency	1 kHz
U _o	5,9 V
I _o	18 mA
P _o	27 mW
C _o	2800 nF
L _o	1 mH

Intrinsically safe serial interface X4	
Number serial interface	1 x RS485
U _o	5,9 V
I _o	96 Ma
P _o	193 mW
C _o	1868 nF
L _o	1 mH
Baudrate	9600 – 38400
Output data (not intrinsically safe)	
Connection side	Connections into the safe area
Switch outputs X5	
Number	3
U max	24 V
I max	50 mA
Serial interface X3	
Number serial interfaces	1 x RS485
U max	8 V
I max	165 mA
Baudrate	9600 - 38400

5.10 Overview of materials in use

Name	Material
Housing	Cast iron, cast steel, stainless steel, aluminum or welded steel
Flow straightener	Delrin, aluminum or steel
Turbine wheel	Delrin or aluminum
Measuring unit	Aluminum
Ball bearings	Stainless steel
Shafts	Stainless steel
Gear wheels	Stainless steel or plastic
Magnetic coupling	Stainless steel
Meter head	Plastic
Meter printed circuit board	Aluminum, zinc die-casting or brass

6 Error messages

Error messages are shown in the display as an error number and "unit" "Err".



Figure 18: Error message in the display

The message types are:

E = Error
W = Warning
H = Hint

There are the following error messages:

Message type	Error no.	Brief description	Comment
E	1	EEPROM version error	Contact RMG service.
E	2	EEPROM error	Contact RMG service.
E	8	Flow rate min/max error	Check the alarm setting for the flow rate.

E	9	X:Y pulse comparison error	Check the alarm setting for the pulse comparison.
E	10	Max. output pulse error	Check the alarm setting for the max. output pulse.
E	11	Current output error	Check your current connections. Contact RMG service in case of uncertainty.
E	12	Error CRC Calibration Parameter	Contact RMG service.
W	101	Warning Battery Capacity low	Please change the battery
H	201	New software version	You have a new firmware version
H	202	Metrology switch open	Metrology switch open
H	203	Code word set	Code word is set

Appendix

A Modbus

The TME 400 has a passive RS-485 interface, which means the interface must be supplied with power externally.

88

Parameterizing the Modbus

Modbus activation

H03 RS-485 protocol

0	Off
1	Modbus RTU (default)
2	Modbus ASCII

The **Modbus - ID** is adjusted via the coordinate H04 (default is 1)

The **Modbus - Register - Offset** (MRO) is entered via coordinate H05 (default is 1). The MRO applies for read and write operations.

Baud rate

H01 Baud rate RS-485 interface

0	2400 Bps
1	9600 Bps
2	19200 Bps
3	38400 Bps (default)

Interface parameters

The interface parameters can be adjusted in coordinate H02.

H02 RS-485 interface parameters

0	8N1 (default)
1	8E1
2	8O1
3	7N1
4	7E1
5	7O1

The TME 400 recognizes the following Modbus commands:

- (03 Hex) Read Holding Registers
- (06 Hex) Preset Single Register
- (10 Hex) Preset Multiple Regs
- (08 Hex) Subfunction 00 Hex: Return Query data

TME 400 Exception Codes

- 01 Illegal Function
- 02 Illegal Data Address (register not available)
- 03 Illegal Data Value (register not writable or incorrect value)

Example (Modbus query/response):

Query:	Send character	
Start Char	:	
Slave Address	01	
Function	03	
Starting Address Hi	07	
Starting Address Lo	CF	2000-1
No. of Points Hi	00	
No. of Points Lo	02	
LRC	24	
carriage return	cr	
line feed	lf	

Response:	Receive character	
Start Char	:	
Slave Address	01	
Function	03	
Byte Count	04	
Data Hi (Reg 2000)	3F	see below
Data Lo (Reg 2000)	80	see below
Data Hi (Reg 2001)	00	see below
Data Lo (Reg 2001)	00	see below
LRC	39	
carriage return	cr	
line feed	lf	

Example (Modbus number formats)

Data type	Register	Value	Byte 1	Byte 2	Byte 3	Byte 4	Byte 5	Byte 6	Byte 7	Byte 8	Byte 9	Byte 10
float	2	1.0	0x3f	0x80	0x00	0x00						
Text	5	"90111200"	0x39	0x30	0x31	0x31	0x31	0x32	0x30	0x30	0x00	0x00
int	1	1357	0x05	0x4d								
long	2	698614	0x00	0x0a	0xa8	0xf6						

Refer to the Modbus specifications for further information.

Characteristics of the TME 400 Modbus

- Data types (float, text ...) can only be read or written completely

menu16	:	1 Register
int16	:	1 Register
uint16	:	1 Register
int32	:	2 Register
uint32	:	2 Register
float	:	2 Register
string8	:	4 Register
string12	:	6 Register

- A maximum of 125 registers can be read or written (in one command)..

- Text fields must have at least one terminating zero (0x00).

- Writing of certain parameters causes internal initialization of the hardware and/or:

- Deletion of intermediate results (pulse output, meter calculation, etc.).
- Therefore, the parameters should only be overwritten as necessary (e.g. meter factor)
- Meter statuses are delivered as a uint32 value (without decimal)

Modbus - Register (Version:0.001; Matrix: 001; June 2018)

MB reg	Reg. number	Data type	MB access	Coordinate	Name	Access	Unit	Description
302	2	uint32	RW	A02	Volume Measurement	E	&VolumeUnit	Volume at measurement conditions
306	2	uint32	RW	A04	Volume Measurement Error	E	&VolumeUnit	Volume at meas. conditions error
308	2	uint32	RW	A05	Volume Measurement uncor.	E	&VolumeUnit	Volume at measurement conditions uncorrected
310	2	uint32	RW	A06	Volume Start/Stop	N	&VolumeUnit	Volume Start/Stop
312	2	uint32	RW	A07	Volume Reset	N	&VolumeUnit	Volume Reset
314	2	uint32	RW	G06	Metering Point	E	---	Name of met. point

91

MB reg	Reg. number	Data type	MB access	Coordinate	Name	Access	Unit	Description
320	2	float	R	B02	Flow Rate Measurement	A	&FlowUnit	Flow rate measurement
322	2	float	R	B03	Frequency	A	Hz	Frequency
330	2	float	R	F01	Current	A	mA	Current to be output
332	1	uint16	R	Z10	Error Register 1	A	Hex	Error register 1
333	1	uint16	R	Z11	Error Register 2	A	Hex	Error register 2
334	1	uint16	R	Z12	Status Register 1	A	Hex	Status register 1
335	1	uint16	R	Z13	Status Register 2	A	Hex	Status register 2

MB reg	Reg. number	Data type	MB access	Coordinate	Name	Access	Unit	Description
500	6	string12	RW	A10	Meter Factor	E	&CounterFactorUnit	Meter factor
506	2	float	RW	A11	Output Pulse Factor	E	&CounterFactorUnit	Output pulse factor
508	2	float	R	A12	Meter Factor corrected	A	&CounterFactorUnit	Meter factor corrected
510	1	menu16	RW	A20	Display Factor	E		Display factor
511	1	menu16	RW	A21	Digital Output 2 Mode	E		Digital output 2 mode
512	1	menu16	RW	A22	Digital Output 2 Pulse Width	N	ms	Digital output 2 pulse width

MB reg	Reg. number	Data type	MB access	Coordinate	Name	Access	Unit	Description
521	2	float	RW	B05	Flow Rate min.	E	&FlowUnit	Flow rate minimum
523	2	float	RW	B06	Flow Rate max.	E	&FlowUnit	Flow rate maximum

MB reg	Reg. number	Data type	MB access	Coordinate	Name	Access	Unit	Description
--------	-------------	-----------	-----------	------------	------	--------	------	-------------

527	2	float	RW	B08	QmUg	E	&FlowUnit	
529	1	uint16	RW	B09	QmMinTime	E	s	
530	2	float	RW	B10	Coefficient A-2	E	Am2	Error curve linearization coefficient A-2
532	2	float	RW	B11	Coefficient A-1	E	Am1	Error curve linearization coefficient A-1
534	2	float	RW	B12	Coefficient A0	E	A0	Error curve linearization coefficient A0
536	2	float	RW	B13	Coefficient A1	E	A1	Error curve linearization coefficient A1
538	2	float	RW	B14	Coefficient A2	E	A2	Error curve linearization coefficient A2
540	2	float	RW	B15	KKMaxProz	E	kkp	

MB reg	Reg. number	Data type	MB access	Coordinate	Name	Access	Unit	Description
657	1	menu16	RW	F02	Current Mode	N		Mode current output
658	1	menu16	RW	F03	Current Source	N		Source current output
659	2	float	RW	F04	Physical minimum value	N		Current output phys. minimum value
661	2	float	RW	F05	Physical maximum value	N		Current output phys. maximum value
663	2	float	RW	F06	Current default	N	mA	Current output default
665	2	float	RW	F07	Current Damping	N	I-D	Damping current output
667	2	float	RW	F10	Calibration Value 4mA	N	mA	Calibration: Actual value 4mA
669	2	float	RW	F11	Calibration Value 20mA	N	mA	Calibration: Actual value 20mA
671	4	string8	RW	F12	Module Serial Number	N	SN	Current output module serial no.
675	1	uint16	R	G01	Current Error	A	ERR	Current activated error codes
676	2	float	R	G02	Software Version	A	Rev	Software version

MB reg	Reg. number	Data type	MB access	Coordinate	Name	Access	Unit	Description
680	2	int32	RW	G04	Serial number	E	SNr	Serial number
682	1	uint16	R	G05	Firmware Checksum	A	CRC	Firmware checksum
683	2	float	R	G10	Pressure Base	A	bar	Pressure at base condition
685	2	float	R	G11	Pressure Range Min.	A	bar	Pressure range minimum
687	2	float	R	G12	Pressure Range Max	A	bar	Pressure range maximum
689	6	string12	R	G13	Pressure Sensor Serial Number	A	---	Serial number pressure sensor
695	2	float	R	G14	Temperature Base	A	TN	Temperature at base condition
697	2	int32	RW	G17	Temp. Sensor Serial Number	E	TNr	Serial number temperature sensor

MB reg	Reg. number	Data type	MB access	Coordinate	Name	Access	Unit	Description
699	2	int32	RW	G18	Serial Number Gas Meter	E	ZNr	Serial number gas meter
701	4	string8	RW	G19	Meter size	E	G	Meter size
705	3	string8	RW	G20	Date of Battery Exchange	C	Bat	Date of battery exchange
790	1	uint16	R	G24	Remaining Battery Capacity	A	%	Remaining Battery Capacity
791	1	menu16	RW	G25	Battery Change	C	-	Battery Change
792	2	uint16	R	G26	Operating Hours	A	h	Operating Hours

93

MB reg	Reg. number	Data type	MB access	Coordinate	Name	Access	Unit	Description
709	1	menu16	RW	H01	RS485 Baudrate	N	Bps	RS485 interface baudrate
710	1	menu16	RW	H02	RS485 Parameter	N		RS485 interface parameter
711	1	menu16	RW	H03	RS485 Protocol	N		RS485 selection of protocol
712	1	uint16	RW	H04	Modbus ID	N	MID	Modbus ID
713	1	uint16	RW	H05	Modbus Register Offset	N	Mof	Modbus register offset
714	3	string8	RW	X01	Time	E	T	Time
717	3	string8	RW	X02	Date	E	D	Date

MB reg	Reg. number	Data type	MB access	Coordinate	Name	Access	Unit	Description
722	1	menu16	RW	X10	Delete Parameter Archive	E		Delete parameter archive
723	1	uint16	R	X11	Fill level Para. Archive	A	%	Fill level parameter archive
724	1	menu16	RW	X12	Delete Parameter Archive(E)	E		Delete parameter archive (E)
725	1	uint16	R	X13	Fill level Para. Archive (E)	A	%	Fill level parameter archive (E)
726	1	menu16	RW	X14	Delete Event Archive	E		Delete event archive
727	1	uint16	R	X15	Fill level Event Archive	A	%	Fill level event archive
728	1	menu16	RW	X16	Mode archives	E		Mode Archives
729	1	menu16	RW	X17	Interval Minute Archive	E		Interval minute archiv
730	1	menu16	RW	X18	Delete Minute Archive	E		Delete minute archive
731	1	uint16	R	X19	Fill level Minute Archive	A	%	Fill level minute archive
732	1	menu16	RW	X20	Delete Day Archive	E		Delete day archive
733	1	uint16	R	X21	Fill level Day Archive	A	%	Fill level day archive
734	1	menu16	RW	X22	Delete Month archive	E		Delete month archive
735	1	uint16	R	X23	Fill level Month Archive	A	%	Fill level month archive

MB reg	Reg. number	Data type	MB access	Coordinate	Name	Access	Unit	Description
812	1	menu16	W	X24	Delete all archives	E	-	Deleting of all archives
775	1	uint16	RW	Z04	X:Y maximum Pulse Errors	E	X	Pulse compare X:Y maximum pulse errors
776	1	uint16	RW	Z05	X:Y maximum Pulses	E	Y	Pulse compare X:Y maximum pulses
777	1	uint16	RW	Z15	Code Word Input	N	COD	Code word input
778	1	uint16	RW	Z16	Code Word Change	C	C-V	Code word change
779	1	menu16	RW	Z17	Device Type	E		Device type
780	1	menu16	RW	Z24	Display on max.	N		Maximum time display on
781	1	menu16	RW	Z25	Volume Count Mode	E		Selection mode of volume counter
782	1	menu16	RW	Z26	Curve Linearization	E		Selection curve linearization
783	1	menu16	RW	Z27	Sensor Type 1	E		Selection turbine sensor channel 1
784	1	menu16	RW	Z28	Sensor Type 2	E		Selection turbine sensor channel 2
785	1	menu16	RW	Z29	Unit Volume	E		Selection volume unit
819	1	uint16	R	Z42	Warning Register 1	A	Hex	Warning register 1
820	1	uint16	R	Z43	Warning Register 2	A	Hex	Warning register 2
821	1	uint16	R	Z44	Hint Register 1	A	Hex	Hint register 1
822	1	uint16	R	Z45	Hint Register 2	A	Hex	Hint register 2

The Modbus access has the meaning:

R = no protection
 RW = calibration button

Error, warning, hint and status registers

MB reg	Reg. number	Data type	MB access	Bit	Description	Event number
332	1	uint16	R	0	-	-
				1	Error: Power-Fail	1
				2	Error: EEprom	2
				3	Error: Pt1000-Hardware	3
				4	Error: Temperature min/max	4
				5	Error: Pressure Sensor-Hardware	5
				6	Error: Pressure min/max	6
				7	Error: Calculation Gas Equations	7
				8	Error: Flow min/max	8
				9	Error: Pulse Comparison X:Y	9
				10	Error: max. Output Pulses	10
				11	Error: Current Output	11
				12	Error: CRC Calibration Parameter	12
				13 ... 15	-	-
333	1	uint16	R		Not assigned	-
334	1	uint16	R	0	-	-
				1	Status: Code Word enabled	
				2	Status: Calibration switch open	
				3	Status: External Power Supply RS485 on	
				4	Status: Current Loop on	
				5	Status: Pulse Input 1 closed	
				6	Status: Pulse Input 2 closed	
				7	Status: Digital Input 1 closed	
				8	Status: Battery Capacity < 10%	
				9 ... 15	-	-
335	1	uint16	R		Not assigned	-
819	1	uint16	R	0	-	-
				1	Warning: Battery Capacity < 10%	101
				2 ... 15	-	-
820	1	uint16	R		Not assigned	-
821	1	uint16	R	0 ... 1	-	-
				2	Hint: Calibration Switch open	202
				3	Hint: Code Word enabled	203
				4 ... 15	-	-
822	1	uint16	R		Not assigned	-

B Structure of the archives

In this appendix you will find more information about the archives:

- Archive size
- Archive types
 - Parameter archives
 - Event archives
 - Measured values archives
- Calculation of the storage size
- Archive header
- Reading the archive data via Modbus

B1 Archive size

The TME 400 has an archive storage divided into the following archive types with the given archive sizes:

Event archive	200 Entries
Parameter archive (custody transfer)	300 Entries
Parameter archive (non-custody transfer)	300 Entries
Month archive	25 Entries
Day archive	100 Entries
Periodic archive	9000 Entries

B2 Archive types

Below is a list of further data on the parameter, event and measured value archives.

B2.1 Parameter archives

The parameter archive contains the history of all parameter changes. The time of the change and the old and the new parameter values are stored in the archive.

The parameter archives are divided into one archive each for custody transfer and non-custody transfer parameters.

 97

Internal structure of an entry:

Content	Data type	Length in Bytes
Position number	UINT16	2
Unix time (device time)	UINT32	4
Coordinate	UINT16	2
Old parameter value	CHAR	12
New parameter value	CHAR	12
CRC16 (Modbus)	UINT16	2
		Total length: 34

Coordinate:

- High byte: column („A“-„Z“ as ASCII)
- Low byte: line

A value in the coordinate field 4103h corresponds to coordinate A 03.

B2.2 Event archives

The event archive stores error messages, warnings and notes that occurred or disappeared during operation of the TME 400.

Internal structure of an entry:

Content	Data type	Length in Bytes
Position number	UINT16	2
Unix time (device time)	UINT32	4
Event type	UINT16	2
Event number	UINT16	2
CRC16 (Modbus)	UINT16	2
		Total length: 12

Event type:

- High byte: type ('E' = error, 'W' = warning, 'H' = note)
- Low byte: 0 = Event passes, 1 = Event is coming

B2.3 Measured values archives

In the measured value archives, meter readings and average values of important measured variables are periodically stored.

There are three types of measured value archives implemented:

- Periodic archive (adjustable: 15, 30 or 60 minutes)
- Daily archive
- Monthly archive

Internal structure of an entry:

Content	Data type	Length in Bytes
Position number	UINT16	2
Unix time (device time)	UINT32	4
Standard volume	UINT32	4
Operating volume	UINT32	4
Standard volume Error	UINT32	4
Operating volume Error	UINT32	4
Exponent (to base 10)	INT16	2
Mean pressure	FLOAT	4
Mean temperature	FLOAT	4
Mean compressibility	FLOAT	4
Status	UINT16	2
CRC16 (Modbus)	UINT16	2
		Total length: 40

When reading out the measured value archives with the RMGView software, additional information on the archive values is displayed in the status field.

The status field in the month/day and period archive has a data width of 16 bits and is bit-encoded. Each bit represents the occurrence of an error event that has affected the data in one of the measurement value archives.

If a relevant error event occurs during the recording interval of the respective archive (e.g. daily archive between 00:00:00 and 23:59:59), it remains stored in the status field even if the error event no longer exists within the recording interval.

At the beginning of the new period, the status field is reset to 0 and rewritten in the event of an error.

A set bit in the status field therefore indicates that an error event has occurred.

The error event may have

- occurred briefly and disappeared again during the recording interval, or
- occurred and still be pending.

The value displayed in the status field is in hexadecimal notation and must be converted to binary notation in order to determine the exact error.

The following conversion table applies, whereby it should be noted that binary notation is always read from right to left.

Hexadecimal	Binary
0	0
1	1
2	10
3	11
4	100
5	101
6	110
7	111
8	1000
9	1001
A	1010
B	1011
C	1100
D	1101
E	1110
F	1111
10	10000
20	100000
40	1000000
80	10000000
100	100000000

The coding of the status field is shown in the table below:

Bit	Error	Explanation
0	Temperature error	The temperature measurement is outside the specified min/max limits (coordinates D04, D05). The set default value for the temperature (coordinate D03) is used. The cause may be a defective PT100 temperature sensor.
1	Pressure error	The pressure measurement is outside the specified min/max limits (coordinates C04, C05). The set default value for the pressure (coordinate C03) is used. The cause may be a defective pressure sensor.
2	Error equation of state	An error has occurred in the equation of state used (coordinate E05) during the conversion of the operating volume. The default value for the K number (coordinate E06) is used. The cause may be a temperature or pressure value that is outside the permitted range of the equation of state.
3	10 to 10000 pulse comparison errors	When operating the turbine in 2-channel mode, a deviation of more than 10 pulses occurred between the measurement channel and the reference channel. The possible cause may be a faulty sensor sleeve.
8	Time reset	The time and/or date was changed by the user during the recording interval.

 101

Example of a display in the status field:

The status field shows a value of 09h (h = hexadecimal).

This value is translated into binary notation: 00001001b (b = binary), that means bit 0 and bit 3 are set.

It follows that a temperature error and a 10 to 10000 pulse comparison error occurred during the recording interval.

B3 Calculation of the storage size

The total available storage for archives is 506880 bytes.

Archive type	Bytes / entry	Amount entries	Sum in bytes
Parameter archive (custody transfer)	34	300	10200
Parameter archive (non-custody transfer)	34	300	10200
Event archive	12	200	2400
Periodic archive	40	9000	360000
Daily archive	40	100	4000
Monthly archive	40	25	1000
Sum			387800

B4 Archive header

Each archive type contains an administration header that gives information about how to access the archive.

The header is arranged as follows:

Content	Data type	Length in Bytes
Position number of the next archive (largest value = 9999, then again = 0)	UINT16	2
Index oldest entry	UINT16	2
Index newest entry	UINT16	2
CRC16 (Modbus)	UINT16	2
		Total length: 8

There are four headers for each archive type, which are organized in memory as ring buffers. This is to ensure that the information is stored safely in case of cell defects in the EEPROM. Each time a new archive entry is written, the corresponding archive header is updated and stored as the next entry in the ring buffer:

Empty header ring buffer at the beginning after writing a new entry:

Storage index	
0	Archive header (Position number 1) -> Actual header
1	empty
2	empty
3	empty

Ring buffer after the writing of four entries:

Storage index	
0	Archive header (Position number 1)
1	Archive header (Position number 2)
2	Archive header (Position number 3)
3	Archive header (Position number 4) -> Actual header

Ring buffer after the writing of six entries:

Index	
0	Archive header (Position number 5)
1	Archive header (Position number 6) -> Actual header
2	Archive header (Position number 3)
3	Archive header (Position number 4)

Content of an empty header:

Content	Data type	Value
Position number of the next archive	UINT16	0
Index of the oldest entry	UINT16	FFFFh
Index of the newest entry	UINT16	FFFFh
CRC16	UINT16	xxxxh

Content of the header after the writing of the first archive entry:

Inhalt	Data type	Value
Position number of the next archive	UINT16	1
Index of the oldest entry	UINT16	0
Index of the newest entry	UINT16	0
CRC16	UINT16	xxxxh

Content of the header after the writing of the second archive entry:

Content	Data type	Value
Position number of the next archive	UINT16	2
Index of the oldest entry	UINT16	0
Index of the newest entry	UINT16	1
CRC16	UINT16	xxxxh

104

Content header after the writing of the 300th archive entry (archive full):

Content	Data type	Value
Position number of the next archive	UINT16	300
Index of the oldest entry	UINT16	0
Index of the newest entry	UINT16	299
CRC16	UINT16	xxxxh

Content header after the writing of the 301st archive entry (archive full, oldest entry overwritten in the ring buffer):

Content	Data type	Value
Position number of the next archive	UINT16	301
Index of the oldest entry	UINT16	1
Index of the newest entry	UINT16	0
CRC16	UINT16	xxxxh

Procedure for determining the indexes to be read in the archive:

- Reading all four archive headers of an archive type
- Recognizing the current header
- Determine the range to be read:
If "Index oldest entry" = FFFFh and
"Index newest entry" = FFFFh, then the corresponding archive is empty

If "Index oldest entry" = 0 and "Index newest entry" = 0, then
the archive contains an entry
- If "Index oldest entry" < "Index newest entry", then the
Number of entries = "Index newest entry" - "Index oldest entry" + 1
- If "Index oldest entry" > "Index newest entry", then the
No. of ent. = max. archive ent. - "Index older ent." + "Index newest ent." + 1
(Archive is always full: Number of entries = Maximum archive entries,
Calculation for the purpose of completeness only)

B5 Reading the archive data via Modbus

Archive entries are accessible via Modbus. The command 14h "Read General Reference" is used for this. This command can be used to index the storage ranges of the archives and the corresponding management headers (see document: "Modicon Modbus Protocol; Reference Guide (PI-MBUS-300 Rev. J)")

The TME 400 only supports the processing of a sub-request within one request.

105

The structure of the request string is as follows:

Byte	Meaning
1	Device address
2	Function (14h)
3	Number of bytes (07h)
4	Reference type (00h)
5	File number (Hi)
6	File number (Lo)
7	Start index (Hi)
8	Start index (Lo)
9	Number of registers to be read (Hi)
10	Number of registers to be read (Lo)
11	CRC (Lo)
12	CRC (Hi)

The specified reference type in the request string is not checked in the TME 400.

The following file number selects the archive or archive header to be read:

File number	Archive type
1	Management header custody transfer parameter archive
2	Custody transfer parameter archive
3	Management header parameter archive
4	Parameter archive
5	Management header event archive
6	Event archive
7	Management header minutes archive
8	Minutes archive
9	Management header daily archive
10	Daily archive
11	Management header monthly archive
12	Monthly archive

With the file address the index of the archive to be read is selected.

The number of registers of the bytes which are read from an archive entry (number of bytes = number of registers x 2). The maximum number of registers to be read is limited to 125 per request.

The following example shows the data to be read in a request:

- File number: 6 (Event archive, size: 12 Byte per entry)
- Start index: 7 (Read from index 7)
- Number of registers: 13

Archive index	Modbus register	Internal storage address of the TME 400
7	1 (Hi)	0 (+ Offset)
	1 (Lo)	1 (+ Offset)
	2 (Hi)	2 (+ Offset)
	2 (Lo)	3 (+ Offset)

	6 (Hi)	10 (+ Offset)
8	6 (Lo)	11 (+ Offset)
	7 (Hi)	12 (+ Offset)
	7 (Lo)	13 (+ Offset)
	8 (Hi)	14 (+ Offset)
	8 (Lo)	15 (+ Offset)

9	12 (Hi)	22 (+ Offset)
	12 (Lo)	23 (+ Offset)
	13 (Hi)	24 (+ Offset)
	13 (Lo)	24 (+ Offset)

The example shows the reading of two complete event archive entries (index 7 and 8) and a part archive (2 bytes from index 9). In practice, it makes sense to request only complete archives. The above case is used exclusively to illustrate the mechanism.

C Dimensions

TME 400-VM

Front side

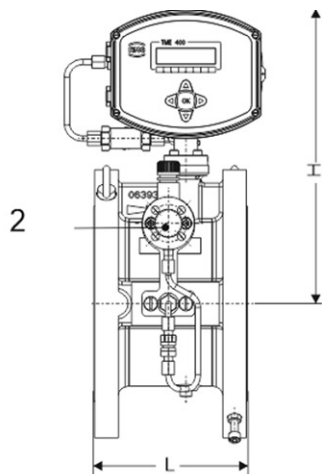

Rear side

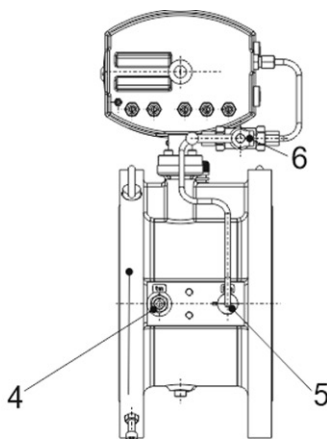

7

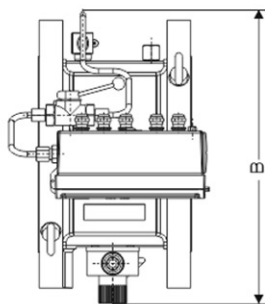

8

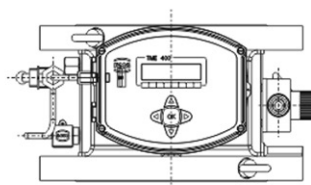

- 1 -
- 2 Oil pump
- 3 -
- 4 -

- 5 -
- 6
- 7 Top view
- 8 Top view for flow direction from bottom top up to DN200

107

Size		Max. Flow rate Qmax m ³ /h	Dimensions			Weight kg
mm	Inch		Length L	Width B	Hight H	
25	1	25	185	135	225	2
40	1 1/2	70	140	255	225	5
50	2	100	150	245	265	15
80	3	160	120	265	290	18
		250				
		400				
100	4	400	150	260	306	25
		650				
150	6	650	175	320	330	40
		1000				
		1600				
200	8	1600	200	370	365	55
		2500				
250	10	2500	300	430	400	PN 10 = 60 PN 25 = 75
		4000				
300	12	4000	300	600	410	PN 25 = 103 PN10 = 86
		6500				
400	16	6500	600	640	420	PN10 = 190 PN16 = 210 PN40 = 300
		10000				

TME 400-VMF

Front view

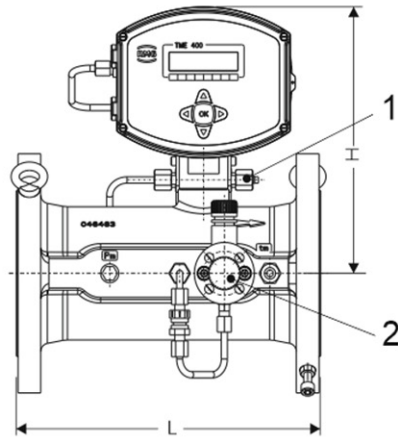

7

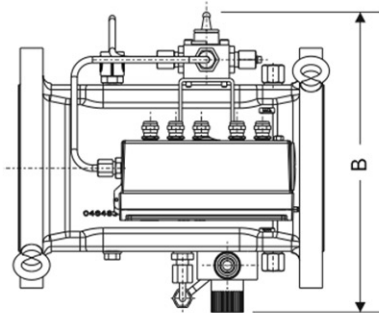

Rear side

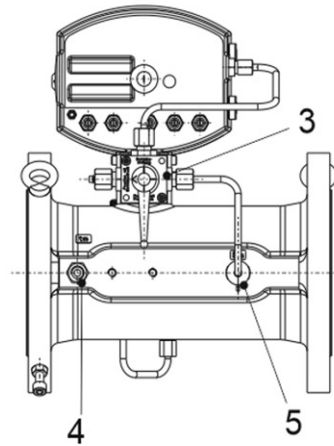

8

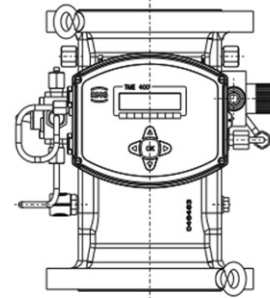

- 1 -
- 2 Oil pump
- 3 -
- 4 -

- 5 -
- 6 -
- 7 Top view
- 8 Top view for flow direction from bottom top up to DN200

110

Size		G-Size	Max. Flow rate Qmax m3/h	Dimensions			Weight kg
mm	Inch			Length L	Width B	Hight H	
50	2	G65	65	150	320	310	15
80	3	G100	160	240	270	250	20
		G160	250				
		G250	400				
100	4	G160	250	300	285	254	28
		G250	400				
		G400	650				
150	6	G400	650	450	310	280	50
		G650	1000				
		G1000	1600				
200	8	G1000	1600	600	380	320	100
		G1600	2500				
250	10	G1000	1600	750		345	ANSI150 = 160 PN16 = 150 PN10 = 150
		G1600	2500				
		G2500	4000				
300	12	G2500	4000	900		360	ANSI150 = 250 PN16 = 215 PN10 = 210
		G4000	6500				
		G4000-45	6500**				

Remote meter

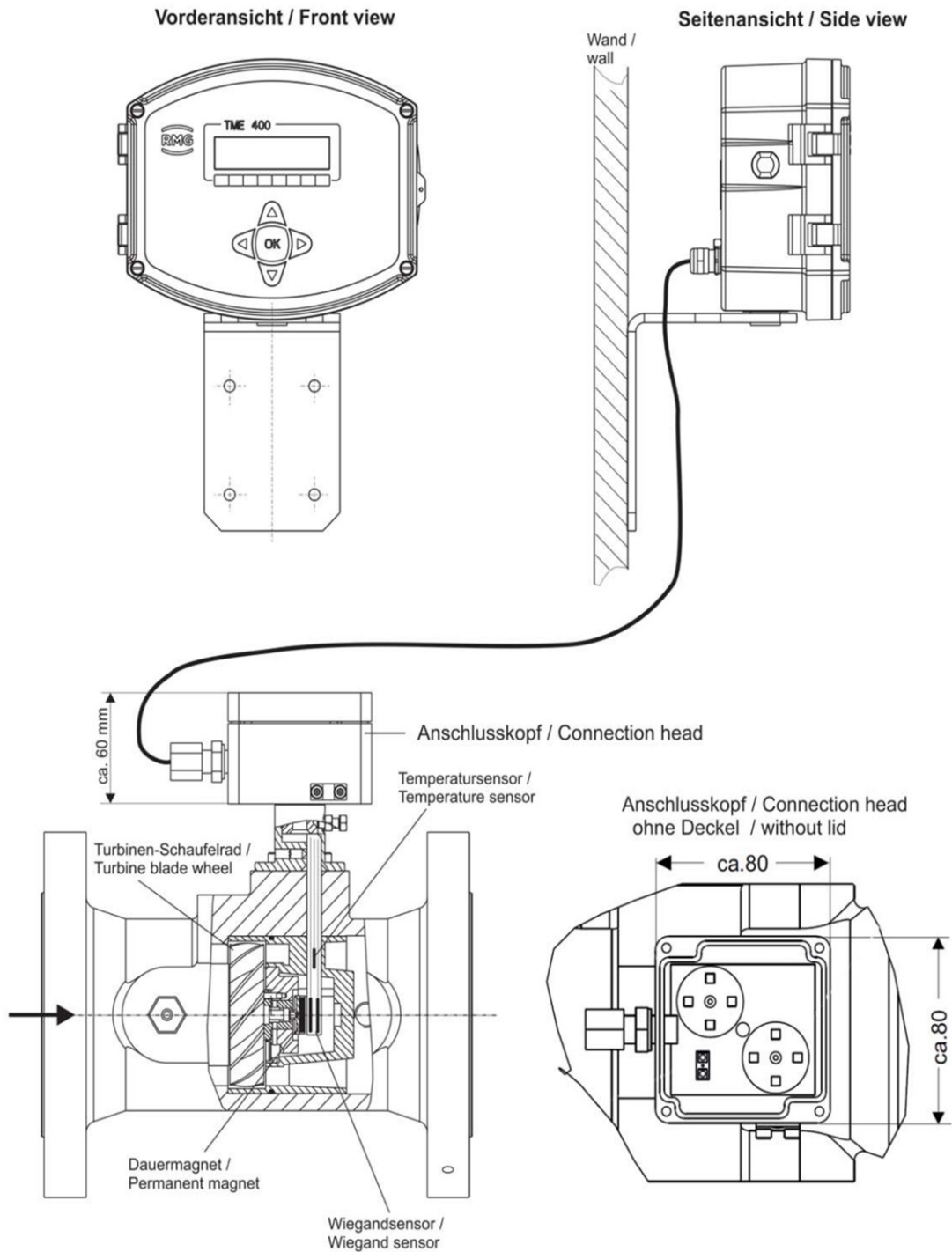

111

Cable length: 10 m
 Pressure sensor: integrated in the connection head
 Height: approx. 80 mm less than the „normal“ height (see above)

D Measuring ranges for TME 400-VMF/ TME 400-VCF

Values for custody transfer metering according to MID approval with natural gas

112

DN [mm]	G- value	Q _{max} [m ³ /h]	Flow [m ³ /h] at p _{min} =1 bar ^[1] MR ^[2] 1:20		Q _{min} [m ³ /h] depending on operating pressure p _{min} [bar(g)]											
			Q _t	Q _{min}	MR 1:30		MR 1:50		MR 1:80		MR 1:100		MR 1:120		MR 1:160	
					Q _{min}	p _{min}	Q _{min}	p _{min}	Q _{min}	p _{min}	Q _{min}	p _{min}	Q _{min}	p _{min}	Q _{min}	p _{min}
50	65	100	20	5 ^[3]												
80	100	160	32	8 ^[3]	5	15	3,2	50								
	160	250	50	12,5	8	3	5	10	3,2	50						
	250	400	80	20	13	3	8	10	5	25						
100	160	250	50	12,5	8	3	5	25								
	250	400	80	20	13	3	8	10	5	25						
	400	650	130	32	20	3	13	4	8	10	6,5	15	5	25		
150	400	650	130	32	20	3	13	10	8	25	6,5	40				
	650	1000	200	50	32	3	20	4	13	10	10	15	8	25		
	1000	1600	320	80	50	3	32	4	20	10	16	15	13	25	10	40
200	1000	1600	320	80	50	3	32	4	20	10	16	15	13	25	10	40
	1600	2500	500	125	80	3	50	4	32	10	25	15	20	25	16	40
250	1000	1600	320	80	50	3	32	10	20	25	16	40				
	1600	2500	500	125	80	3	50	4	32	10	25	25	20	40	16	60
	2500	4000	800	200	130	3	80	4	50	10	40	25	35	40	25	60
300	2500	4000	800	200	130	3	80	4	50	10	40	25	35	40	25	60
	4000	6500	1300	320	220	3	130	10	80	25	65	40	55	60	40	80
	4000-45	6500	1300	320	220	3	130	10	80	25	65	40	55	60	40	80

[1] p = 1 bar; means atmospheric pressure

[2] MR = Measuring range = Q_{max} / Q_{min}

[3] MR: 1:20; for p ≥ 3 bar(g)

E Measuring accuracy for TME 400-VM

DN	Qmin [m³/h] Qmax [m³/h]		MR	Error of measurement in the range		with error curve linearization ¹⁾ Qmin to Qmax	MR extension with error curve linearization ¹⁾ and limited measuring accuracy				
	Qmin [m³/h]	Qmax [m³/h]		Qmin to 0.2 Qmax	0.2 Qmax to Qmax		MB	Qmin [m³/h]	Qmin to Qmax		
25	2,5	25	1:10	±6%	±2%	±1%	1	Qmin to Qmax			
40	6	70	1:12	±1.5%	±1%				3	1:25	
50	6	100	1:16								±3%
80	13	160	1:12	±2%		±1%	8	1:30			
	16	250	1:16		±1%				8	13	
	25	400									±1%
100	25	400	1:16	±3%		±1.5%	8	1:30			
	40	650			±1%				13	20	
80	13	250	1:20								±2%
	20	400		±0,5%		13	20	1:40			
100	20	400			±1%				13	20	
	32	650									±1%
150	32	650		±1%		30	50	1:40			
	50	1000			±1%				30	50	
	80	1600									±1%
200	80	1600		±1%		50	80	1:40			
	125	2500			±1%				80	130	
250	125	2500									±1%
	200	4000		±1%		130	200	1:40			
300	200	4000	1:20		±1%				130	200	
	325	6500									±1%
400	325	6500		±1%		200	200	1:40			
	500	10000			±1%				320	320	
500	500	10000									±1%
	800	16000		±1%		320	320	1:40			
600	800	16000			±1%				500	500	
	1250	25000									±1%

DN [mm]	Size	Q _{max} [m ³ /h]	Flow rates at p _{min} =air,atm		Measuring error for pressures < 3barg		Measuring error for pressures ≥ 3barg	
			Q _{min} [m ³ /h] MR ⁽¹⁾ 1:20	Q _t [m ³ /h] MR 1:20	in the range Q _{min} to 0,2Q _{max}	with error curve correction ⁽³⁾ Q _{min} to Q _{max}	in the range Q _{min} to 0,2Q _{max}	with error curve correction ⁽³⁾ Q _{min} to Q _{max}
50	G 65	100	5 ²⁾	20	±2%	±1%	±1%	±0,5%
80	100	160	8 ²⁾	32	±1%	±1%	±1%	±0,5%
	160	250	12,5	50				
	250	400	20	80				
100	160	250	12,5	50				
	250	400	20	80				
	400	650	32	130				
150	400	650	32	130				
	650	1000	50	200				
	1000	1600	80	320				
200	1000	1600	80	320				
	1600	2500	125	500				
250	1000	1600	80	320				
	1600	2500	125	500				
	2500	4000	200	800	±2%	±1%	±1%	±0,25%
300	2500	4000	200	800				
	4000	6500	320	1300				
	4000-45	6500	320	1300				
400	4000	6500	320	1300				
	6500	10000	500	2000				
	6500-45	10000	500	2000				
500	6500	10000	500	2000				
	10000	16000	800	3200				
	10000-45	16000	800	3200				
600	10000	16000	800	3200				
	16000	25000	1250	5000				

For TME 400-VMF

[1] MR = Measuring range = Q_{max}/Q_{min}

[2] MR 1:20 for p_{min} ≥ 3barg

[3] Correction of the error curve must be specified when ordering (extra charge); note the information for operation with correction of the error curve, see man-

F Type plate

Main type plate TME 400-VM for DN25, for Non-Ex, no custody transfer applications

TME400-VM		CE	
DN	<input type="text"/>		
Q max	<input type="text"/>	m³/h	T min <input type="text"/> °C
Q min °C	<input type="text"/>	m³/h	T max <input type="text"/> °C
PS <small>brennbare Gase flammable gas</small>	<input type="text"/> 5	bar	
PS <small>nichtbrennbare Gase non-flammable gas</small>	<input type="text"/>	bar	IP65
TS	<input type="text"/>		
S.-Nr./S.-no.	<input type="text"/>		
Jahr/Year	<input type="text"/>		
		RMG Messtechnik GmbH Otto-Hahn-Str. 5 35510 Butzbach / Germany	RMG

115

Main type plate TME 400-VM from DN40, for Non-Ex, no custody transfer applications

TME400-VM		CE 0091	
DN	<input type="text"/>		T min <input type="text"/> °C
Q max	<input type="text"/>	m³/h	T max <input type="text"/> °C
Q min	<input type="text"/>	m³/h	
PS	<input type="text"/>	bar	IP65
TS	<input type="text"/>		
S.-Nr./S.-no.	<input type="text"/>		
Jahr/Year	<input type="text"/>		
		RMG Messtechnik GmbH Otto-Hahn-Str. 5 35510 Butzbach / Germany	RMG

Main type plate TME 400-VM for DN25, for Ex, no custody transfer applications

TME400-VM		CE 0158		II 2 G Ex ia IIC T4 Gb -25°C ≤ T _{amb} ≤ +55°C TÜV 17 ATEX 207566X IECEx TUN 18.0009 X
DN	<input type="text"/>			
Q max	<input type="text"/>	m ³ /h	T min <input type="text"/> °C	
Q min	<input type="text"/>	m ³ /h	T max <input type="text"/> °C	
PS <small>brennbare Gase flammable gas</small>	<input type="text"/>	5 bar	IP65	
PS <small>nichtbrennbare Gase non-flammable gas</small>	<input type="text"/>	bar		
TS	<input type="text"/>			
S.-Nr./S.-no.	<input type="text"/>			Elektrische Daten siehe EU- Baumusterprüfbescheinigung Electrical data see certificate
Jahr/Year	<input type="text"/>			
		RMG Messtechnik GmbH Otto-Hahn-Str. 5 35510 Butzbach / Germany		

Main type plate TME 400-VM from DN40, for Ex, no custody transfer applications

TME400-VM		CE 0091 0158		II 2 G Ex ia IIC T4 Gb -25°C ≤ T _{amb} ≤ +55°C TÜV 17 ATEX 207566X IECEx TUN 18.0009 X
DN	<input type="text"/>			
Q max	<input type="text"/>	m ³ /h	T min <input type="text"/> °C	
Q min	<input type="text"/>	m ³ /h	T max <input type="text"/> °C	
PS	<input type="text"/>	bar	IP65	
TS	<input type="text"/>			
S.-Nr./S.-no.	<input type="text"/>			Elektrische Daten siehe EU- Baumusterprüfbescheinigung Electrical data see certificate
Jahr/Year	<input type="text"/>			
		RMG Messtechnik GmbH Otto-Hahn-Str. 5 35510 Butzbach / Germany		

Main type plate TME 400-VMF, for custody transfer applications

TME400-VMF		AC 1,0 IP65			0091 0158 0102
DN	<input type="text"/>		T min	<input type="text"/>	°C
Q max	<input type="text"/>	m³/h	T max	<input type="text"/>	°C
Q min	<input type="text"/>	m³/h	T11741 / TC11907		
Q t	<input type="text"/>		t _{am} = -25°C...+55°C		
PS	<input type="text"/>	bar	RMG		
TS	<input type="text"/>		Elektrische Daten siehe EU-Baumusterprüfbescheinigung Electrical data see certificate		
S.-Nr./S.-no.	<input type="text"/>				
Jahr/Year	<input type="text"/>				
			RMG Messtechnik GmbH Otto-Hahn-Str. 5 35510 Butzbach / Germany		

II 2 G Ex ia IIC T4 Gb
 -25°C ≤ T_{amb} ≤ +55°C
 TÜV 17 ATEX 207566X
 IECEx TUN 18.0009 X

← Type plate for Non-Ex version →
 ← Type plate for Ex version →

G Seal diagrams

The following figures show the positions of the seals on the TME 400.

Front side

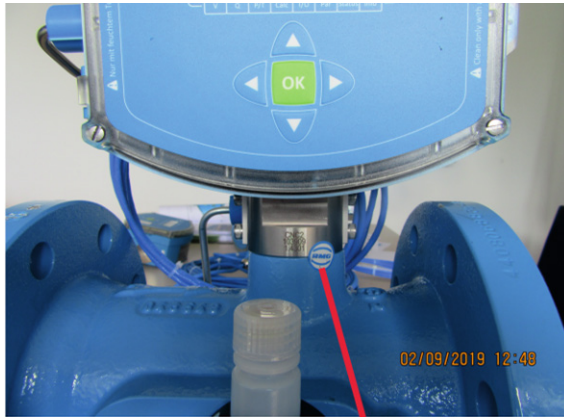

Security seal
Sicherheitsplombe

Back side

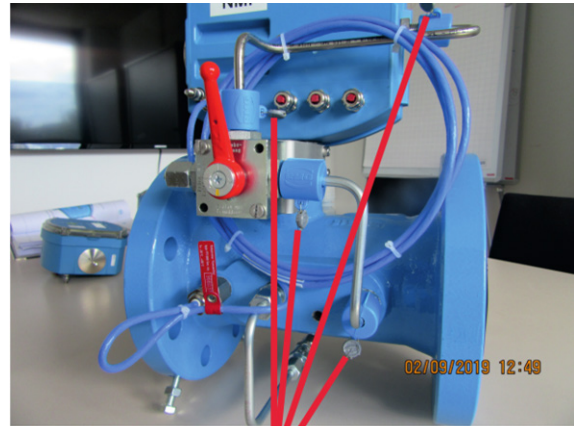

Seal cap with lead seal
Siegelkappe mit Bleiplombe

In the electronic enclosure

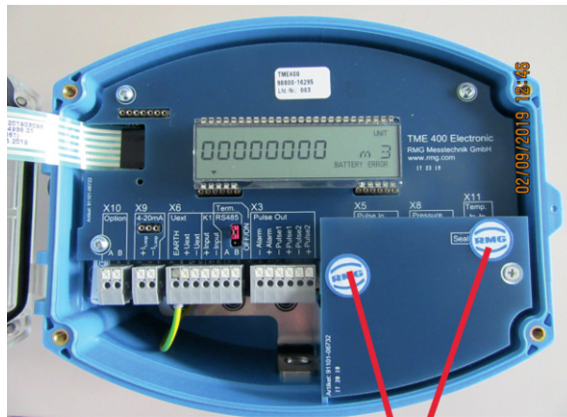

Security seal
Sicherheitsplombe

At the connection head



Sicherheitsplombe
Security seal

H Later installation of the power module

⚠ Caution
 The power module must only be installed in a de-energized state.

In order to switch of any power supply the battery must be removed (see *chapter 3.1.4 Battery replacement*) and any external supply voltage must be switched off, i.e. in the case of an external supply, the wires from terminals X6 / +Uext and X6 / -Uext must be removed.

The power module (3) must be plugged on as shown in *Figure 19: Electronic with power module*. The current module is factory adjusted and **does not need** to be calibrated before operation.

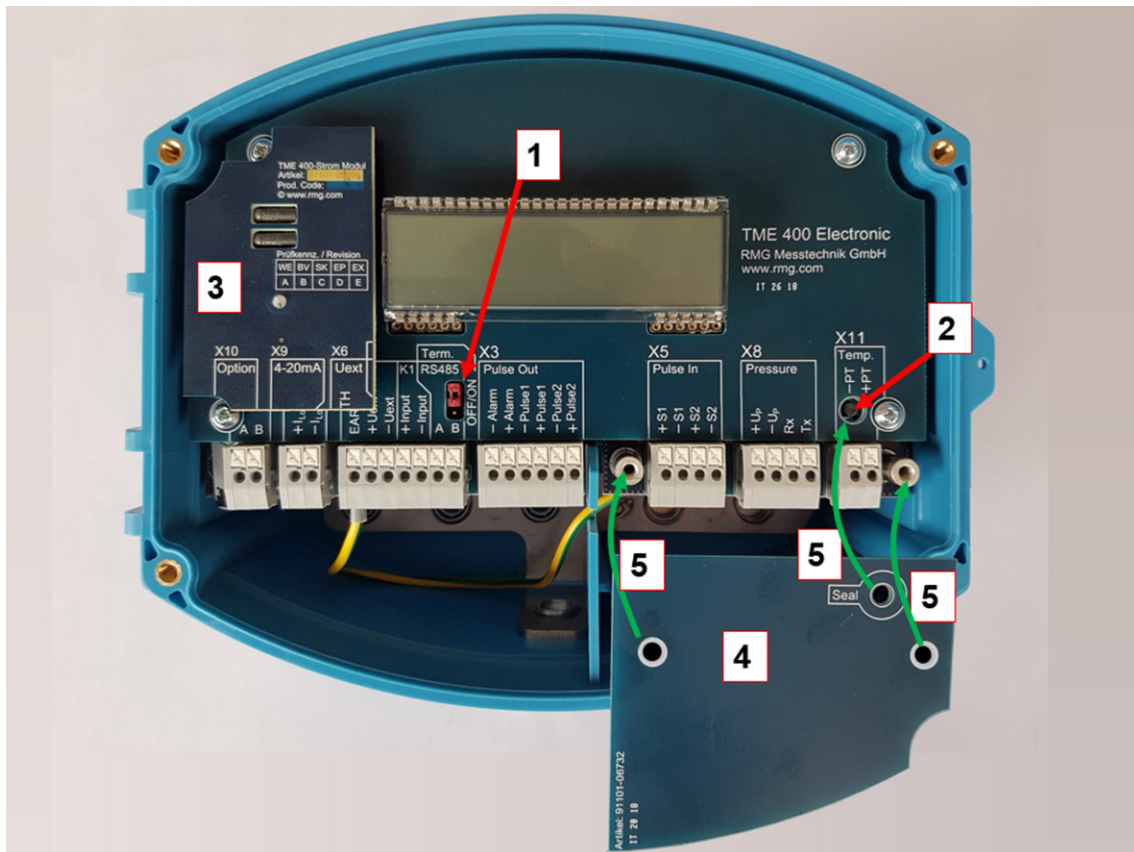

Figure 19: Electronic with power module

- 1 Jumper for RS 485 terminating resistor. Bridged: with 120 Ω; open: ∞ Ω
- 2 Calibration switch
- 3 Current module board
- 4 Cover plate for pressure and temperature sensor and calibration switch
- 5 Normal position, indicated by green arrows

Putting the power module into operation

After reconnecting the TME 400 supply voltages, the current loop power supply must be connected to X9 and the current output parameterized.

Caution

The voltages of the current loop and the external supply must be electrically isolated (galvanically isolated see *chapter 2.1 Electrical connections*, especially the connection drawings in the Ex- /Non-Ex area at the end of the chapter).

Parameterization of the current module

To complete the installation, various parameters must be checked or configured. To do this, the parameter protection must be removed, either by entering the code word (see *chapter 4.3.3.7 Settings*) or by pressing the calibration button (see *Figure 19: Electronic with power module*).

1. First the date and time must be entered in the coordinates X1 and X2
2. The current output parameters F02, F03, F04, F05 (see *chapter 4.3.3.3 Current output*) must then be parameterized according to the application.

For example, a typical parameterization may look like this:

F02:	1	Without error
F03:	1	Operating flow rate
F04:	0	i.e. 4 mA = 0 m ³ /h
F05:	200	i.e. 20 mA = 200 m ³ /h

For testing, F03 can be set to 0 (default) and a current value in the range of 4 - 20mA can be selected with F06.

I Spare parts and accessories

Parts of the versions TME 400-VM and TME 400-VC

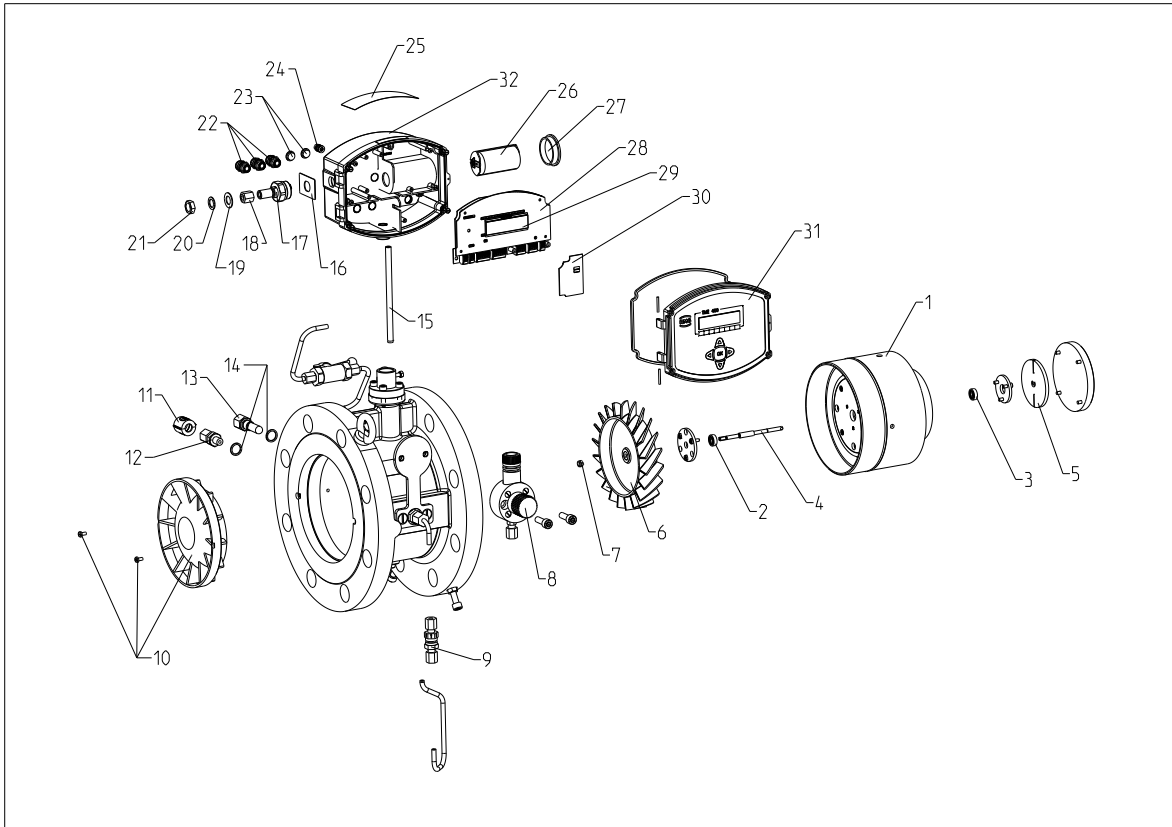

The spare parts marked in red in the following tables are intended exclusively for replacement by RMG service partners!

TME 400-VM/VC (DN 25-DN 100)

Dr.no.	Article description	DN25	DN40	DN50	DN80	DN100
1	Measuring chamber complete with lubrication	-	00.65.957.00	00.65.957.00	00.49.655.00	00.50.253.00
1	Measuring chamber complete without lubrication	00.65.961.00	00.65.959.00	00.65.959.00	00.52.945.00	00.53.409.00
2	front ball bearing	65.19.333.00	65.19.372.00	65.19.372.00	65.19.351.00	65.19.352.00
3	Rear ball bearing	65.19.332.00	30.00.399.00	30.00.399.00	65.19.372.00	65.19.380.00
4	Drive shaft	00.52.416.00	00.50.231.00	00.50.231.00	00.64.257.00	00.50.348.00
5	Disk and magnet (screw and ring included)	integrated in drive shaft dr.-pos. 4	integrated in drive shaft dr.-pos. 4	integrated in drive shaft dr.-pos. 4	integrated in drive shaft dr.-pos. 4	00.64.258.00 1x 66.64.515.00 1x
6	Turbine wheel 45° aluminium	-	00.47.680.00	00.47.680.00	00.46.745.00	00.46.471.00
	Turbine wheel 30° aluminium	-	-	-	00.48.224.00	00.48.046.00
	Turbine wheel 45° plastic	00.52.364.00	00.47.110.00	00.47.110.00	00.46.743.00	00.46.472.00
	Turbine wheel 30° plastic	-	-	-	00.49.528.00	00.49.529.00
	Turbine wheel bushing	-	-	-	00.46.811.00 1x	00.60.235.00 1x
	Screws turbine wheel aluminium	-	-	-	61.22.079.00 2x	61.24.152.00 3x
	Set screw turbine wheel aluminium	-	-	-	62.40.109.00 1x	62.40.109.00 1x
	Set screw turbine wheel plastic	-	-	-	-	64.34.012.00 1x
7	Nut turbine wheel	-	62.66.070.00	62.66.070.00	62.66.070.00	62.66.072.00
8	Lubrication pump	-	90.59.266.00	90.59.266.00	90.59.266.00	90.59.266.00
9	Check valve	84.08.021.00	84.08.021.00	84.08.021.00	84.08.021.00	84.08.021.00
10	Flow straightener with screws	00.52.369.00	00.55.533.00	00.47.170.00 1x 61.34.211.00 2x	00.48.650.00 1x 61.34.211.00 2x	00.47.339.00 1x 61.34.211.00 2x
11	Seal for screw connector	00.60.316.00	00.60.316.00	00.60.316.00	00.60.316.00	00.60.316.00
12	Screw-in connector (standard)	67.00.215.00	67.00.215.00	67.00.215.00	67.00.215.00	67.00.215.00
13	Thermowells	-	-	00.56.533.14	00.55.523.14	00.55.523.14
14	Sealing ring G1/4 Sealing ring G3/8	81.54.614.00	81.54.614.00	81.54.614.00	81.54.614.00	81.54.614.00
15	Sensor VM	01.64.368.00	01.64.368.00	01.64.368.00 or sandwich bodies 01.64.368.01 for ductile cast iron bodies 01.64.368.02 for steel cast bodies	01.64.368.06 for ductile cast iron and steel cast bodies 01.64.368.03 for round material bodies PN10/16 01.64.368.04 for round material bodies A300/600RF	01.64.368.07 for ductile cast iron bodies and steel cast bodies and round material bodies A300RF 01.64.368.05 for round material bodies PN10/16 01.64.368.08 for round material bodies A600RF

15	Sensor VC	01.64.368.30 01.64.368.60 class A	01.64.368.30 01.64.368.60 class A	01.64.368.30 for sandwich bodies 01.64.368.60 class A for sandwich bodies 01.64.368.31 for ductile cast iron bodies 01.64.368.61 class A for ductile cast iron bodies 01.64.368.32 for steel cast bodies 01.64.368.62 class A for steel cast bodies	01.64.368.36 for ductile cast iron and steel cast bodies 01.64.368.66 class A for ductile cast iron and steel cast bodies 01.64.368.33 for round material bodies PN10/16 01.64.368.63 class A for round material bodies PN10/16 01.64.368.34 for round material bodies 01.64.368.64 class A for round material bodies A300/600RF	01.64.368.37 for ductile cast iron and steel cast bodies and round material bodies A300RF 01.64.368.67 class A for ductile cast iron and steel cast bodies and round material bodies A300RF 01.64.368.35 for round material bodies PN10/16 01.64.368.65 class A for round material bodies PN10/16 01.64.368.38 for round material bodies A600RF 01.64.368.68 class A for round material bodies A600RF
16	Locking plate (only VC)	00.67.200.00	00.67.200.00	00.67.200.00	00.67.200.00	00.67.200.00
17	Pressure transmitter (only VC)	98800-17180 0.8-2.5 bar 98800-17190 0.8-6 bar 98800-17200 2-10 bar 98800-17210 4-20 bar 98800-17360 8-40 bar	98800-17180 0.8-2.5 bar 98800-17190 0.8-6 bar 98800-17200 2-10 bar 98800-17210 4-20 bar 98800-17360 8-40 bar	98800-17180 0.8-2.5 bar 98800-17190 0.8-6 bar 98800-17200 2-10 bar 98800-17210 4-20 bar 98800-17360 8-40 bar	98800-17180 0.8-2.5 bar 98800-17190 0.8-6 bar 98800-17200 2-10 bar 98800-17210 4-20 bar 98800-17360 8-40 bar	98800-17180 0.8-2.5 bar 98800-17190 0.8-6 bar 98800-17200 2-10 bar 98800-17210 4-20 bar 98800-17360 8-40 bar
18	Cap nut and compression ring for pressure transmitter (only VC)	67.08.655.00 67.08.132.00	67.08.655.00 67.08.132.00	67.08.655.00 67.08.132.00	67.08.655.00 67.08.132.00	67.08.655.00 67.08.132.00
19	Sealing ring pressure transmitter (only VC)	30.00.609.00	30.00.609.00	30.00.609.00	30.00.609.00	30.00.609.00
20	Adjusting washer pressure transmitter (only VC)	66.50.018.00	66.50.018.00	66.50.018.00	66.50.018.00	66.50.018.00
21	Counternut pressure transmitter (only VC)	67.97.090.00	67.97.090.00	67.97.090.00	67.97.090.00	67.97.090.00
22	Cable gland	87.06.090.00	87.06.090.00	87.06.090.00	87.06.090.00	87.06.090.00
23	Blind plug	87.05.092.00	87.05.092.00	87.05.092.00	87.05.092.00	87.05.092.00
24	Outer grounding	30.00.503.00 1x 62.80.611.00 3x 62.62.519.00 2x 30.00.382.00 1x	30.00.503.00 1x 62.80.611.00 3x 62.62.519.00 2x 30.00.382.00 1x	30.00.503.00 1x 62.80.611.00 3x 62.62.519.00 2x 30.00.382.00 1x	30.00.503.00 1x 62.80.611.00 3x 62.62.519.00 2x 30.00.382.00 1x	30.00.503.00 1x 62.80.611.00 3x 62.62.519.00 2x 30.00.382.00 1x

25	Name plate	order specific, specify device serial number	order specific, specify device serial number	order specific, specify device serial number	order specific, specify device serial number	order specific, specify device serial number
26	Battery (cable included)	98800-16560 92102-00200	98800-16560 92102-00200	98800-16560 92102-00200	98800-16560 92102-00200	98800-16560 92102-00200
27	Battery cover	30.00.597.00	30.00.597.00	30.00.597.00	30.00.597.00	30.00.597.00
28	Electronic (preconfigured) LCD display included	98800-16296	98800-16296	98800-16296	98800-16296	98800-16296
29	LCD display	91501-00370	91501-00370	91501-00370	91501-00370	91501-00370
30	Power module	98800-16590	98800-16590	98800-16590	98800-16590	98800-16590
31	Cover with spiral spring and sealing	00.66.083.00 1x 00.66.145.00 1x 30.00.374.00 2x	00.66.083.00 1x 00.66.145.00 1x 30.00.374.00 2x	00.66.083.00 1x 00.66.145.00 1x 30.00.374.00 2x	00.66.083.00 1x 00.66.145.00 1x 30.00.374.00 2x	00.66.083.00 1x 00.66.145.00 1x 30.00.374.00 2x
32	Electronic meter head complete	98800-17120 VM 98800-17130 0.8-2.5bar 98800-17140 0.8-6bar 98800-17160 2-10bar 98800-17170 4-20bar 98800-17370 4-40bar	98800-17120 VM 98800-17130 0.8-2.5bar 98800-17140 0.8-6bar 98800-17160 2-10bar 98800-17170 4-20bar 98800-17370 4-40bar	98800-17120 VM 98800-17130 0.8-2.5bar 98800-17140 0.8-6bar 98800-17160 2-10bar 98800-17170 4-20bar 98800-17370 4-40bar	98800-17120 VM 98800-17130 0.8-2.5bar 98800-17140 0.8-6bar 98800-17160 2-10bar 98800-17170 4-20bar 98800-17370 4-40bar	98800-17120 VM 98800-17130 0.8-2.5bar 98800-17140 0.8-6bar 98800-17160 2-10bar 98800-17170 4-20bar 98800-17370 4-40bar

TME 400-VM/VC (DN 150-DN 400)

Dr.no.	Article description	DN150	DN200	DN250	DN300	DN400
1	Measuring chamber complete with lubrication	00.52.960.00	00.50.310.00	00.51.937.00	00.52.868.00	00.51.921.00
1	Measuring chamber complete without lubrication	00.50.279.00	-	-	-	-
2	Front ball bearing	65.19.355.00	65.19.356.00	65.19.359.00	65.19.359.00	65.19.361.00
3	Rear ball bearing	65.19.355.00	65.19.353.00	65.19.356.00	65.19.356.00	65.19.359.00
4	Drive shaft	00.50.282.00	00.50.313.00	00.59.099.00	00.52.864.00	00.52.815.00
5	Disk and magnet (screw and ring included)	00.50.283.00 1x 62.41.111.00 2x 90.50.334.00 2x 66.64.530.00 1x	00.50.315.00 1x 90.50.334.00 2x 62.40.121.00 2x -	00.51.929.00 1x 62.40.121.00 2x 90.50.334.00 2x -	00.52.865.00 1x 62.38.905.00 2x 90.50.334.00 2x -	00.51.920.00 1x 62.38.905.00 2x 90.50.334.00 2x -
6	Turbine wheel 45° aluminium Turbine wheel 30° aluminium Turbine wheel 45° plastic Turbine wheel 30° plastic Turbine wheel bushing Screws turbine wheel aluminium Set screw turbine wheel aluminium Woodruff key	00.46.566.00 00.47.999.01 00.46.739.00 00.49.530.00 00.46.633.00 1x 61.24.221.00 3x 62.40.782.00 1x -	00.46.567.00 00.46.877.00 00.52.934.00 00.52.952.00 00.47.270.00 1x 60.64.035.00 3x -	00.46.565.00 00.46.878.00 - - 00.46.619.00 1x 60.64.066.00 4x -	00.46.569.00 - 00.46.879.00 - 00.47.242.00 1x 60.64.066.00 4x -	00.47.196.00 - 00.47.197.00 - 00.47.244.00 1x 60.64.066.00 4x -

7	Nut turbine wheel	62.66.074.00	62.66.078.00	62.66.082.00	62.66.082.00	62.66.082.00
8	Lubrication pump	90.59.266.00	90.59.266.00	90.59.266.00 for PN10,16,25,ANSI150 and above	90.59.265.00	90.59.265.00
9	Rückschlagventil / check valve	84.08.021.00	84.08.021.00	84.08.021.00	84.08.021.00	84.08.021.00
10	Flow straightener with screws	80.30.003.00 1x 61.34.211.00 2x	00.47.264.00 1x 61.34.211.00 2x	00.47.536.00 1x 61.34.238.00 3x	00.47.528.00 1x 61.34.238.00 3x	00.64.650.00 1x 61.34.266.00 3x
11	Seal for screw connector	00.60.316.00	00.60.316.00	00.60.316.00	00.60.316.00	00.60.316.00
12	Screw-in connector (standard)	67.00.215.00	67.00.215.00	67.00.205.00	67.00.215.00	67.00.215.00
13	Thermowells	00.55.518.14	00.55.518.14	00.54.365.14	00.54.365.14	00.58.647.14
14	Sealing ring G1/4 Sealing ring G3/8	81.54.614.00	81.54.614.00	81.54.614.00 therm. 81.54.374.00 Pm	81.54.614.00	81.54.614.00
15	Sensor VM	01.64.368.06 for ductile cast iron and steel cast bodies 01.64.368.08 for round material bodies A600RF	01.64.368.08 for ductile cast iron and steel cast bodies PN10,16,A150 01.64.368.09 for round material bodies A300 and steel cast bodies PN25/40 01.64.368.10 for round material bodies A600	01.64.368.10 for welding bodies and round material bodies A300 01.64.368.13 for round material bodies A600	01.64.368.11	01.64.368.12
15	Sensor VC	01.64.368.36 for ductile cast iron and steel cast bodies 01.64.368.66 class A for ductile cast iron and steel cast bodies 01.64.368.38 for round material bodies A600RF 01.64.368.68 class A for round material bodies A600RF	01.64.368.38 for ductile cast iron and steel cast bodies PN10,16,A150 01.64.368.68 class A for ductile cast iron and steel cast bodies PN10,16,A150 01.64.368.39 for round material bodies A300 and steel cast bodies PN25/40 01.64.368.69 class A for round material bodies A300 and steel cast bodies PN25/40	01.64.368.40 for welding bodies and round material bodies A300 01.64.368.70 class A for welding bodies and round material bodies A300 01.64.368.43 for round material bodies A600 01.64.368.73 class A for round material bodies A600	01.64.368.41 01.64.368.71 class A	01.64.368.42 01.64.368.72 class A

15	Sensor VC			01.64.368.40 for round material bodies A600 01.64.368.70 class A for round material bodies A600				
16	Locking plate (only VC)	00.67.200.00	00.67.200.00	00.67.200.00	00.67.200.00	00.67.200.00	00.67.200.00	00.67.200.00
17	Pressure transmitter (only VC)	98800-17180 0.8-2.5 bar 98800-17190 0.8-6 bar 98800-17200 2-10 bar 98800-17210 4-20 bar 98800-17360 8-40 bar	98800-17180 0.8-2.5 bar 98800-17190 0.8-6 bar 98800-17200 2-10 bar 98800-17210 4-20 bar 98800-17360 8-40 bar	98800-17180 0.8-2.5 bar 98800-17190 0.8-6 bar 98800-17200 2-10 bar 98800-17210 4-20 bar 98800-17360 8-40 bar	98800-17180 0.8-2.5 bar 98800-17190 0.8-6 bar 98800-17200 2-10 bar 98800-17210 4-20 bar 98800-17360 8-40 bar	98800-17180 0.8-2.5 bar 98800-17190 0.8-6 bar 98800-17200 2-10 bar 98800-17210 4-20 bar 98800-17360 8-40 bar	98800-17180 0.8-2.5 bar 98800-17190 0.8-6 bar 98800-17200 2-10 bar 98800-17210 4-20 bar 98800-17360 8-40 bar	98800-17180 0.8-2.5 bar 98800-17190 0.8-6 bar 98800-17200 2-10 bar 98800-17210 4-20 bar 98800-17360 8-40 bar
18	Cap nut and compression ring for pressure transmitter (only VC)	67.08.655.00	67.08.655.00	67.08.655.00	67.08.655.00	67.08.655.00	67.08.655.00	67.08.655.00
19	Sealing ring pressure transmitter (only VC)	67.08.132.00	67.08.132.00	67.08.132.00	67.08.132.00	67.08.132.00	67.08.132.00	67.08.132.00
20	Adjusting washer pressure transmitter (only VC)	30.00.609.00	30.00.609.00	30.00.609.00	30.00.609.00	30.00.609.00	30.00.609.00	30.00.609.00
21	Counternut pressure transmitter (only VC)	66.50.018.00	66.50.018.00	66.50.018.00	66.50.018.00	66.50.018.00	66.50.018.00	66.50.018.00
22	Cable gland	67.97.090.00	67.97.090.00	67.97.090.00	67.97.090.00	67.97.090.00	67.97.090.00	67.97.090.00
23	Blind plug	87.06.090.00	87.06.090.00	87.06.090.00	87.06.090.00	87.06.090.00	87.06.090.00	87.06.090.00
24	Outer grounding	87.05.092.00	87.05.092.00	87.05.092.00	87.05.092.00	87.05.092.00	87.05.092.00	87.05.092.00
25	Typenschild / name plate	30.00.503.00 1x 62.80.611.00 3x 62.62.519.00 2x 30.00.382.00 1x	30.00.503.00 1x 62.80.611.00 3x 62.62.519.00 2x 30.00.382.00 1x	30.00.503.00 1x 62.80.611.00 3x 62.62.519.00 2x 30.00.382.00 1x	30.00.503.00 1x 62.80.611.00 3x 62.62.519.00 2x 30.00.382.00 1x	30.00.503.00 1x 62.80.611.00 3x 62.62.519.00 2x 30.00.382.00 1x	30.00.503.00 1x 62.80.611.00 3x 62.62.519.00 2x 30.00.382.00 1x	30.00.503.00 1x 62.80.611.00 3x 62.62.519.00 2x 30.00.382.00 1x
26	Battery (cable included)	order specific, specify device serial number	order specific, specify device serial number	order specific, specify device serial number	order specific, specify device serial number	order specific, specify device serial number	order specific, specify device serial number	order specific, specify device serial number
27	Battery cover	98800-16560	98800-16560	98800-16560	98800-16560	98800-16560	98800-16560	98800-16560
28	Electronic (preconfigured) LCD display included	92102-00200	92102-00200	92102-00200	92102-00200	92102-00200	92102-00200	92102-00200
29	LCD display	30.00.597.00	30.00.597.00	30.00.597.00	30.00.597.00	30.00.597.00	30.00.597.00	30.00.597.00
30	Power module	98800-16296	98800-16296	98800-16296	98800-16296	98800-16296	98800-16296	98800-16296
31	Cover with spiral spring and sealing	91501-00370	91501-00370	91501-00370	91501-00370	91501-00370	91501-00370	91501-00370
32	Electronic meter head complete	98800-16590	98800-16590	98800-16590	98800-16590	98800-16590	98800-16590	98800-16590
		00.66.083.00 1x 00.66.145.00 1x 30.00.374.00 2x	00.66.083.00 1x 00.66.145.00 1x 30.00.374.00 2x	00.66.083.00 1x 00.66.145.00 1x 30.00.374.00 2x	00.66.083.00 1x 00.66.145.00 1x 30.00.374.00 2x	00.66.083.00 1x 00.66.145.00 1x 30.00.374.00 2x	00.66.083.00 1x 00.66.145.00 1x 30.00.374.00 2x	00.66.083.00 1x 00.66.145.00 1x 30.00.374.00 2x
		98800-17120 VM 98800-17130 0.8-2.5bar 98800-17140 0.8-6bar 98800-17160 2-10bar 98800-17170 4-20bar 98800-17370 4-40bar	98800-17120 VM 98800-17130 0.8-2.5bar 98800-17140 0.8-6bar 98800-17160 2-10bar 98800-17170 4-20bar 98800-17370 4-40bar	98800-17120 VM 98800-17130 0.8-2.5bar 98800-17140 0.8-6bar 98800-17160 2-10bar 98800-17170 4-20bar 98800-17370 4-40bar	98800-17120 VM 98800-17130 0.8-2.5bar 98800-17140 0.8-6bar 98800-17160 2-10bar 98800-17170 4-20bar 98800-17370 4-40bar	98800-17120 VM 98800-17130 0.8-2.5bar 98800-17140 0.8-6bar 98800-17160 2-10bar 98800-17170 4-20bar 98800-17370 4-40bar	98800-17120 VM 98800-17130 0.8-2.5bar 98800-17140 0.8-6bar 98800-17160 2-10bar 98800-17170 4-20bar 98800-17370 4-40bar	98800-17120 VM 98800-17130 0.8-2.5bar 98800-17140 0.8-6bar 98800-17160 2-10bar 98800-17170 4-20bar 98800-17370 4-40bar

Parts of the versions TME 400-VMF and TME 400-VCF

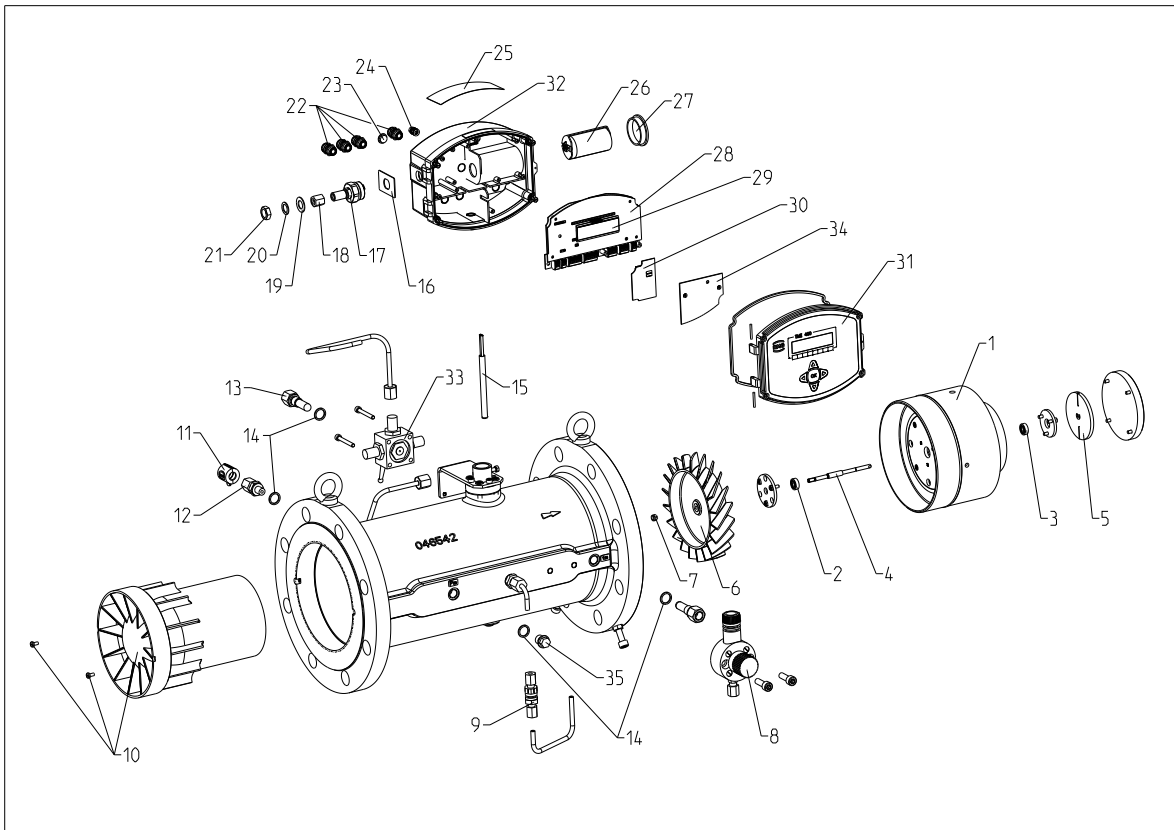

127

The spare parts marked in red in the following tables are intended exclusively for replacement by RMG service partners!

TME 400-VMF/VCF (DN 50-DN 150) en TME 400-VMF/VCF (DN 50-DN 150)

Dr.no.	Article description	DN50	DN80	DN100	DN150
1	Measuring chamber complete with lubrication	00.65.957.00	00.49.655.00	00.50.253.00	00.52.960.00
1	Measuring chamber complete without lubrication	00.65.959.00	00.52.945.00	00.53.409.00	00.50.279.00
2	Front ball bearing	65.19.372.00	65.19.351.00	65.19.352.00	65.19.355.00
3	Rear ball bearing	30.00.399.00	65.19.372.00	65.19.380.00	65.19.355.00
4	Drive shaft	00.50.231.00	00.64.257.00	00.50.348.00	00.50.282.00
5	Disk and magnet (screw and ring included)	Integrated in drive shaft dr.-pos. 4	Integrated in drive shaft dr.-pos. 4	00.64.258.00 1x 66.64.515.00 1x	00.50.283.00 1x 62.41.111.00 2x 90.50.334.00 2x 66.64.530.00 1x
6	Turbine wheel 45° aluminium	00.47.680.00	00.46.745.00	00.46.471.00	00.46.566.00
	Turbine wheel 30° aluminium	-	00.48.224.00	00.48.046.00	00.47.999.01
	Turbine wheel 45° plastic	00.47.110.00	00.46.743.00	00.46.472.00	00.46.739.00
	Turbine wheel 30° plastic	-	00.49.528.00	00.49.529.00	00.49.530.00
	Turbine wheel (aluminium) bushing	-	00.46.811.00 1x	00.60.235.00 1x	00.46.633.00 1x
	Screws turbine wheel aluminium	-	61.22.079.00 2x	61.24.152.00 3x	61.24.221.00 3x
	Set screw turbine wheel aluminium	-	62.40.109.00 1x	62.40.109.00 1x	62.40.782.00 1x
	Set screw turbine wheel plastic	-	-	64.34.012.00 1x	-
7	Nut turbine wheel	62.66.070.00	62.66.070.00	62.66.072.00	62.66.074.00
8	Lubrication pump	90.59.266.00	90.59.266.00	90.59.266.00	90.59.266.00
9	Check valve	84.08.021.00	84.08.021.00	84.08.021.00	84.08.021.00
10	Flow straightener with screws	00.47.170.00 1x 61.34.211.00 2x	00.46.628.00 1x 61.34.211.00 2x	00.46.494.00 1x 61.34.211.00 2x	00.46.543.00 1x 61.34.211.00 2x
11	Seal for screw connector	00.60.316.00	00.60.316.00	00.60.316.00	00.60.316.00
12	Screw-in connector (standard)	67.00.215.00	67.00.215.00	67.00.215.00	67.00.215.00
13	Thermowells	00.56.533.14	00.55.523.14	00.55.518.14	00.55.518.14
14	Sealing ring G1/4	81.54.614.00	81.54.614.00	81.54.614.00	81.54.614.00
15	Sensor VMF	01.64.492.00 for ductile cast iron bodies 01.64.492.01 for steel cast bodies	01.64.492.02 for ductile cast iron bodies 01.64.492.03 for steel cast bodies	01.64.492.04 for ductile cast iron bodies 01.64.492.05 for steel cast bodies	01.64.492.06 for ductile cast iron bodies 01.64.492.07 for steel cast bodies
15	Sensor VCF	01.64.492.32 for ductile cast iron bodies 01.64.492.62 class A for ductile cast iron bodies	01.64.492.30 for ductile cast iron bodies 01.64.492.60 class A for ductile cast iron bodies	01.64.492.34 for ductile cast iron bodies 01.64.492.64 class A for ductile cast iron bodies	01.64.492.36 for ductile cast iron bodies 01.64.492.66 class A for ductile cast iron bodies

15	Sensor VCF	01.64.492.02 alternative with PT1000 for ductile cast iron bodies 01.64.492.33 for steel cast bodies 01.64.492.63 class A for steel cast bodies 01.64.492.03 alternative with PT1000 for steel cast bodies	01.64.492.00 alternative with PT1000 for ductile cast iron bodies 01.64.492.31 for steel cast bodies 01.64.492.61 class A for steel cast bodies 01.64.492.01 alternative with PT1000 for steel cast bodies	01.64.492.04 alternative with PT1000 for ductile cast iron bodies 01.64.492.35 for steel cast bodies 01.64.492.65 class A for steel cast bodies 01.64.492.05 alternative with PT1000 for steel cast bodies	01.64.492.06 alternative with PT1000 for ductile cast iron bodies 01.64.492.37 for steel cast bodies 01.64.492.67 class A for steel cast bodies 01.64.492.07 alternative with PT1000 for steel cast bodies
16	Locking plate (only VCF)	00.67.200.00	00.67.200.00	00.67.200.00	00.67.200.00
17	Pressure transmitter (only VCF)	98800-17180 0.8-2.5 bar 98800-17190 0.8-6 bar 98800-17200 2-10 bar 98800-17210 4-20 bar 98800-17360 8-40 bar	98800-17180 0.8-2.5 bar 98800-17190 0.8-6 bar 98800-17200 2-10 bar 98800-17210 4-20 bar 98800-17360 8-40 bar	98800-17180 0.8-2.5 bar 98800-17190 0.8-6 bar 98800-17200 2-10 bar 98800-17210 4-20 bar 98800-17360 8-40 bar	98800-17180 0.8-2.5 bar 98800-17190 0.8-6 bar 98800-17200 2-10 bar 98800-17210 4-20 bar 98800-17360 8-40 bar
18	Cap nut and compression ring for pressure transmitter (only VCF)	67.08.655.00 67.08.132.00	67.08.655.00 67.08.132.00	67.08.655.00 67.08.132.00	67.08.655.00 67.08.132.00
19	Sealing ring pressure transmitter (only VCF)	30.00.609.00	30.00.609.00	30.00.609.00	30.00.609.00
20	Adjusting washer pressure transmitter (only VCF)	66.50.018.00	66.50.018.00	66.50.018.00	66.50.018.00
21	Counternut pressure transmitter (only VCF)	67.97.090.00	67.97.090.00	67.97.090.00	67.97.090.00
22	Cable gland	87.06.090.00	87.06.090.00	87.06.090.00	87.06.090.00
23	Blind plug	87.05.092.00	87.05.092.00	87.05.092.00	87.05.092.00
24	Outer grounding	30.00.503.00 1x 62.80.611.00 3x 62.62.519.00 2x 30.00.382.00 1x	30.00.503.00 1x 62.80.611.00 3x 62.62.519.00 2x 30.00.382.00 1x	30.00.503.00 1x 62.80.611.00 3x 62.62.519.00 2x 30.00.382.00 1x	30.00.503.00 1x 62.80.611.00 3x 62.62.519.00 2x 30.00.382.00 1x
25	Name plate	order specific, specify device serial number	order specific, specify device serial number	order specific, specify device serial number	order specific, specify device serial number
26	Battery (cable included)	98800-16560 92102-00200	98800-16560 92102-00200	98800-16560 92102-00200	98800-16560 92102-00200
27	Battery cover	30.00.597.00	30.00.597.00	30.00.597.00	30.00.597.00
28	Electronic (preconfigured) LCD display included	98800-16296	98800-16296	98800-16296	98800-16296
29	LCD display	91501-00370	91501-00370	91501-00370	91501-00370
30	Power module	98800-16590	98800-16590	98800-16590	98800-16590

31	Cover with spiral spring and sealing	00.66.083.00 1x 00.66.145.00 1x 30.00.374.00 2x	00.66.083.00 1x 00.66.145.00 1x 30.00.374.00 2x	00.66.083.00 1x 00.66.145.00 1x 30.00.374.00 2x	00.66.083.00 1x 00.66.145.00 1x 30.00.374.00 2x
32	Electronic meter head complete	98800-17120 VMF 98800-17130 0.8-2.5bar 98800-17140 0.8-6bar 98800-17160 2-10bar 98800-17170 4-20bar 98800-17370 4-40bar	98800-17120 VM 98800-17130 0.8-2.5bar 98800-17140 0.8-6bar 98800-17160 2-10bar 98800-17170 4-20bar 98800-17370 4-40bar	98800-17120 VM 98800-17130 0.8-2.5bar 98800-17140 0.8-6bar 98800-17160 2-10bar 98800-17170 4-20bar 98800-17370 4-40bar	98800-17120 VM 98800-17130 0.8-2.5bar 98800-17140 0.8-6bar 98800-17160 2-10bar 98800-17170 4-20bar 98800-17370 4-40bar
33	3-way-valve	84.01.908.14 steel galvanized 30.00.646.00 stainless steel	84.01.908.14 steel galvanized 30.00.646.00 stainless steel	84.01.908.14 steel galvanized 30.00.646.00 stainless steel	84.01.908.14 steel galvanized 30.00.646.00 stainless steel
34	Calibration cover with screws	91101-06732 91203-00600 61.76.017.00 2x	91101-06732 91203-00600 61.76.017.00 2x	91101-06732 91203-00600 61.76.017.00 2x	91101-06732 91203-00600 61.76.017.00 2x

TME 400-VMF/VCF (DN 200-DN 300)

Dr.no.	Article description	DN200	DN250	DN300
1	Measuring chamber complete with lubrication	00.50.310.00	00.51.937.00	00.52.868.00
1	Measuring chamber complete without lubrication	-	-	-
2	Front ball bearing	65.19.356.00	65.19.359.00	65.19.359.00
3	Rear ball bearing	65.19.353.00	65.19.356.00	65.19.356.00
4	Drive shaft	00.50.313.00	00.59.099.00	00.52.864.00
5	Disk and magnet (screw and ring included)	00.50.315.00 1x 90.50.334.00 2x 62.40.121.00 2x	00.51.929.00 1x 62.40.121.00 2x 90.50.334.00 2x	00.52.865.00 1x 62.38.905.00 2x 90.50.334.00 2x
6	Turbine wheel 45° aluminium Turbine wheel 30° aluminium Turbine wheel 45° plastic Turbine wheel 30° plastic Turbine wheel (aluminium) bushing Screws turbine wheel aluminium Set screw turbine wheel aluminium Set screw turbine wheel plastic Woodruff key	00.46.567.00 00.46.877.00 00.52.934.00 00.52.952.00 00.47.270.00 1x 60.64.035.00 3x - - 64.58.030.00 1x	00.46.565.00 00.46.878.00 - - 00.46.619.00 1x 60.64.066.00 4x - - 64.58.040.00 1x	00.46.569.00 - 00.46.879.00 - 00.47.242.00 1x 60.64.066.00 4x - - 64.58.040.00 1x
7	Nut turbine wheel	62.66.078.00	62.66.082.00	62.66.082.00

8	Lubrication pump	90.59.266.00	90.59.266.00 for PN10,16,ANSI150 90.59.265.00 for PN25 and above	90.59.265.00
9	Check valve	84.08.021.00	84.08.021.00	84.08.021.00
10	Flow straightener with screws	00.64.597.00 1x 61.34.211.00 2x	00.64.315.00 1x 61.34.238.00 3x	00.64.330.00 1x 61.34.238.00 3x
11	Seal for screw connector	00.60.316.00	00.60.316.00	00.60.316.00
12	Screw-in connector (standard)	67.00.215.00	67.00.215.00	67.00.215.00
13	Tthermowells	00.54.365.14	00.54.365.14	00.54.365.14
14	Sealing ring G1/4	81.54.614.00	81.54.614.00	81.54.614.00
15	Sensor VMF	01.64.492.08	01.64.492.10	01.64.492.11
15	Sensor VCF	01.64.492.38 standard 01.64.492.68 class A 01.64.492.08 alternative with PT1000	01.64.492.40 standard 01.64.492.70 class A 01.64.492.10 alternative with PT1000	01.64.492.41 standard 01.64.492.71 class A 01.64.492.11 alternative with PT1000
16	Locking plate (only VCF)	00.67.200.00	00.67.200.00	00.67.200.00
17	Pressure transmitter (only VCF)	98800-17180 0,8-2,5 bar 98800-17190 0,8-6 bar 98800-17200 2-10 bar 98800-17210 4-20 bar 98800-17360 8-40 bar	98800-17180 0,8-2,5 bar 98800-17190 0,8-6 bar 98800-17200 2-10 bar 98800-17210 4-20 bar 98800-17360 8-40 bar	98800-17180 0,8-2,5 bar 98800-17190 0,8-6 bar 98800-17200 2-10 bar 98800-17210 4-20 bar 98800-17360 8-40 bar
18	Cap nut and compression ring for pressure transmitter (only VCF)	67.08.655.00 67.08.132.00	67.08.655.00 67.08.132.00	67.08.655.00 67.08.132.00
19	Sealing ring pressure transmitter (only VCF)	30.00.609.00	30.00.609.00	30.00.609.00
20	Adjusting washer pressure transmitter (only VCF)	66.50.018.00	66.50.018.00	66.50.018.00
21	Counter nut pressure transmitter (only VCF)	67.97.090.00	67.97.090.00	67.97.090.00
22	Cable gland	87.06.090.00	87.06.090.00	87.06.090.00
23	Blind plug	87.05.092.00	87.05.092.00	87.05.092.00
24	Outer grounding	30.00.503.00 1x 62.80.611.00 3x 62.62.519.00 2x 30.00.382.00 1x	30.00.503.00 1x 62.80.611.00 3x 62.62.519.00 2x 30.00.382.00 1x	30.00.503.00 1x 62.80.611.00 3x 62.62.519.00 2x 30.00.382.00 1x
25	Name plate	order specific, specify device serial number	order specific, specify device serial number	order specific, specify device serial number
26	Battery (cable included)	98800-16560 92102-00200	98800-16560 92102-00200	98800-16560 92102-00200

27	Battery cover	30.00.597.00	30.00.597.00	30.00.597.00
28	Electronic (preconfigured) LCD display included	98800-16296	98800-16296	98800-16296
29	LCD display	91501-00370	91501-00370	91501-00370
30	Power module	98800-16590	98800-16590	98800-16590
31	Cover with spiral spring and sealing	00.66.083.00 1x 00.66.145.00 1x 30.00.374.00 2x	00.66.083.00 1x 00.66.145.00 1x 30.00.374.00 2x	00.66.083.00 1x 00.66.145.00 1x 30.00.374.00 2x
32	Electronic meter head complete	98800-17120 VM 98800-17130 0.8-2.5bar 98800-17140 0.8-6bar 98800-17160 2-10bar 98800-17170 4-20bar 98800-17370 4-40bar	98800-17120 VM 98800-17130 0.8-2.5bar 98800-17140 0.8-6bar 98800-17160 2-10bar 98800-17170 4-20bar 98800-17370 4-40bar	98800-17120 VM 98800-17130 0.8-2.5bar 98800-17140 0.8-6bar 98800-17160 2-10bar 98800-17170 4-20bar 98800-17370 4-40bar
33	3-way-valve	84.01.908.14 steel galvanized	84.01.908.14 steel galvanized	84.01.908.14 steel galvanized
34	Calibration cover with screws	30.00.646.00 stainless steel 91101-06732 91203-00600 61.76.017.00 2x	30.00.646.00 stainless steel 91101-06732 91203-00600 61.76.017.00 2x	30.00.646.00 stainless steel 91101-06732 91203-00600 61.76.017.00 2x

Order number	Description
--------------	-------------

Expendable materials

92102-00200	Power supply battery
38.11.148.01	Lubricant 2-4°E/20°C TRZ/DKZ 1L
38.11.148.05	Lubricant 2-4°E/20°C TRZ/DKZ 5L

133

Accessories

98800-16590	NonEx TME current module 4-20mA passive
38.02.016.00	EExi supply f.4-20mA current output
86.98.211.01	Power supply 24V/DC 1.4A surface mounted
86.98.249.00	Ex-i power supply 24 V
30.00.619.00	Transmitter power supply KFD2-STC5-1
30.00.733.00	Transmitter power supply KFD2-STC5-Ex1
35.00.013.00	Isolating amplifier TURCK IM1-12-T
30.00.019.00	Interface/pulse separating module Datcom K3
35.00.000.00	PS (230V/AC - 12V/DC) for K3 module
86.76.553.00	OMRON DC/DC adapter for Datcom K3

J Certificates and approvals

The **TME 400** is approved for custody-transfer measurements. Approvals are available for operation in hazardous environments and for the Pressure Equipment Directive, which are provided as copies in the appendix.

1. EU Declaration of Conformity
2. NMI Evaluation Certificate
3. ATEX
4. IECEX
5. EU-Type Examination Certificate Directive 2014/34/EU
6. PED Module D
7. EU-Type Examination Certificate Module B Directive 2014/68/EU
8. Production Quality Assurance
9. EU-Type Examination Certificate Directive 2014/34/EU for Isolating Amplifier type Ex400

The latest version of this manual (and manuals other devices) can be downloaded at your convenience from our Internet page:

www.rmq.com.

Note

EU Declaration of Conformity

The declarations of conformity listed reflect the status on the date of issue of the operating instructions. The latest version of the EU declarations of conformity can be found on our website www.rmq.com.

EU-Declaration of Conformity

EU-Konformitätserklärung



We **RMG Messtechnik GmbH**
 Wir Otto – Hahn – Straße 5
 35510 Butzbach
 Germany

Declare under our sole responsibility that the product is in conformity with the directives. Product is labeled according to the listed directives and standards and in accordance with the Type-Examination.

Erklären in alleiniger Verantwortung, dass das Produkt konform ist mit den Anforderungen der Richtlinien. Das entsprechend gekennzeichnete Produkt ist nach den aufgeführten Richtlinien und Normen hergestellt und stimmt mit dem Baumuster überein.

Product **Turbine Meter TME400VM / Volume Corrector TME400VC**
 Produkt **Turbinenradgaszähler TME400VM / Zustandsmengenumwerter TME400VC**

Harmonisation Legislations <i>Harmonisierungsrechtsvorschriften</i>	EMV	ATEX	PED
EU- Directives <i>EU-Richtlinie</i>	2014/30/EU	2014/34/EU	2014/68/EU
Marking <i>Kennzeichen</i>	---	II 2G Ex ia IIC T4 Gb	---
Normative Documents <i>Normative Dokumente</i>	EN 61000-6-3:2012 EN 61000-4-2:2009 EN 61000-4-3:2011 EN 61000-4-4:2013 EN 61000-4-5:2015 EN 61000-4-6:2014 EN 61000-4-8:2010 EN 61000-6-29:2001	EN IEC 60079-0:2018 /AC:2020-02 EN 60079-11:2012	AD 2000 – Merkblätter
EU Type-Examination issued by <i>EU-Baumusterprüfung ausgestellt durch</i>	Prüfbericht Test Report: 1-5557/17-01-03_A (Fa. CTC advanced)	Modul B TÜV 17 ATEX 207566 X TÜV Nord CERT GmbH Germany	Modul B ISG-22-22-1096_Rev. 05 TÜV Hessen Germany
Approval of a Quality System by <i>Anerkennung eines Qualitätssicherungssystems durch</i>	---	Modul D BVS 23 ATEX ZQS/E139 Notified Body: 0158 DEKRA Testing and Certification GmbH	Modul D 73 202 2839 Notified Body: 0091 TÜV Hessen Germany



The object of the declaration described above is in conformity with Directive 2011/65/EU of the European Parliament and of the Council of 8 June 2011 on the restriction of the use of certain hazardous substances in electrical and electronic equipment.

Der oben beschriebene Gegenstand der Erklärung erfüllt die Vorschriften der Richtlinie 2011/65/EU des Europäischen Parlaments und des Rates vom 8. Juni 2011 zur Beschränkung der Verwendung bestimmter gefährlicher Stoffe in Elektro- und Elektronikgeräten.

RMG Messtechnik GmbH
 Butzbach, den 27.09.2024

Thorsten Dietz
 (CEO)

Sascha Körner
 (Technical Manager)

EU-Declaration of Conformity
EU-Konformitätserklärung



We **RMG Messtechnik GmbH**
Wir Otto – Hahn – Straße 5
35510 Butzbach
Germany

Declare under our sole responsibility that the product is in conformity with the directives. Product is labeled according to the listed directives and standards and in accordance with the Type-Examination.
Erklären in alleiniger Verantwortung, dass das Produkt konform ist mit den Anforderungen der Richtlinien. Das entsprechend gekennzeichnete Produkt ist nach den aufgeführten Richtlinien und Normen hergestellt und stimmt mit dem Baumuster überein.

Product **Turbine Meter with optional EVCD, TME400VMF + TME400VCF**
Produkt **Turbinenradgaszähler mit/ohne Zustandsmengenumwerter, TME400VMF + TME400VCF**

Harmonisation Legislations <i>Harmonisierungsrechtsvorschriften</i>	EMV	ATEX	PED	MID
EU- Directives <i>EU-Richtlinie</i>	2014/30/EU	2014/34/EU	2014/68/EU	2014/32/EU
Marking <i>Kennzeichen</i>	---	II 2G Ex ia IIC T4 Gb	---	
Normative Documents <i>Normative Dokumente</i>	EN 61000-6-3:2012 EN 61000-4-2:2009 EN 61000-4-3:2011 EN 61000-4-4:2013 EN 61000-4-5:2015 EN 61000-4-6:2014 EN 61000-4-8:2010 EN 61000-6-29:2001	EN IEC 60079-0:2018 /AC:2020-02 EN 60079-11:2012	AD 2000 – Merkblätter	EN 12261:2018 EN 12405-1: 2005+A2:2010 Welmec-Guide 7.2
EC Type-Examination issued by <i>EU-Baumusterprüfung ausgestellt von</i>	Prüfbericht/ Test Report: 1-5557/17-01-03_A (Fa. CTC advanced)	Modul B TÜV 17 ATEX 207566 X TÜV Nord CERT GmbH Germany	Modul B ISG-22-22-1097 Rev 02 TÜV Hessen Germany	Modul B T11741 / T11742 NMI Netherland
Approval of a Quality System by <i>Anerkennung eines Qualitätssicherungssystems durch</i>	---	Modul D BVS 23 ATEX ZQS/E139 Notified Body: 0158 DEKRA Testing and Certification GmbH	Modul D 73 202 2839 Notified Body: 0091 TÜV Hessen Germany	Modul D DE-M-AQ-PTB023 Notified Body: 0102 PTB Germany



The object of the declaration described above is in conformity with Directive 2011/65/EU of the European Parliament and of the Council of 8 June 2011 on the restriction of the use of certain hazardous substances in electrical and electronic equipment.

Der oben beschriebene Gegenstand der Erklärung erfüllt die Vorschriften der Richtlinie 2011/65/EU des Europäischen Parlaments und des Rates vom 8. Juni 2011 zur Beschränkung der Verwendung bestimmter gefährlicher Stoffe in Elektro- und Elektronikgeräten.

RMG Messtechnik GmbH
Butzbach, den 27.09.2024

Thorsten Dietz
(CEO)

Sascha Körner
(Technical Manager)

Sitz der Gesellschaft Butzbach • Registergericht Friedberg HRB 2535
Geschäftsführung Thorsten Dietz
Qualitätsmanagement DIN EN ISO 9001:2015



Evaluation Certificate

Number **TC11907** revision 5
 Project number 3651541
 Page 1 of 1

Issued by NMI Certin B.V.,

In accordance with
 - WELMEC 8.8, 2017 "General and Administrative Aspects of the Voluntary System of Modular Evaluation of Measuring instruments under the MID"
 - European Standard EN 12405-1:2005+A2:2010 "Gas meters – Conversion devices – Part 1: volume conversion".

Producer RMG Messtechnik GmbH
 Otto-Hahn-Straße 5
 35510 Butzbach
 Germany

Part **A calculating and indicating device**, intended to be used as part of an electronic gas-volume conversion device (EVCD) or gas meter
 Type : TME400-VCF (config. 1a/1b*)
 TME400-VMF (config. 2a/2b*)

Manufacturer's mark or name : RMG

Conversion principle (config. 1a/1b*) : T, PT or PTZ
 Conversion principle (config. 2a/2b*) : None (* see description page 1)
 Ambient temperature range : -25 °C / +55 °C
 Designed for : Condensing and non-condensing humidity

Environment classes : M2 / E2
 The intended location for the instrument is open.

Further properties are described in the annexes:
 - Description TC11907 revision 5;
 - Documentation folder TC11907-4.

Initially issued 4 September 2020

Remark This revision replaces the earlier versions, including its documentation folder.

Issuing Authority **NMI Certin B.V., Notified Body number 0122**
 4 May 2023

Certification Board

NMI Certin B.V.
 Thijsseweg 11
 2629 JA Delft
 The Netherlands
 T +31 88 636 2332
certin@nmi.nl
www.nmi.nl

This document is issued under the provision that no liability is accepted and that the manufacturer shall indemnify third-party liability.
 The designation of NMI Certin B.V. as Notified Body can be verified at <http://ec.europa.eu/growth/tools-databases/mando/>

Reproduction of the complete document only is permitted.
 This document is digitally signed and sealed. The digital signature can be verified in the blue ribbon at the top of the electronic version of this certificate.





EU-type examination certificate

Number **T11741** revision 1
Project number 3651541
Page 1 of 1

Issued by	NMi Certin B.V., designated and notified by the Netherlands to perform tasks with respect to conformity modules mentioned in article 17 of Directive 2014/32/EU, after having established that the Measuring instrument meets the applicable requirements of Directive 2014/32/EU, to:
Manufacturer	RMG Messtechnik GmbH Otto-Hahn-Strasse 5 D-35510, Butzbach Germany
Measuring instrument	A Turbine Gas Meter with optional EVCD Types : TME400-VCF TME400-VMF Manufacturer's mark or name : RMG Messtechnik Destined for the measurement of : Gas volume Accuracy class Turbine meter : Class 1,0 Environment classes : M1 / E2 Environment temperature range : -25 °C / +55 °C Gas temperature range : -25 °C / +55 °C
Valid until	4 September 2030
Initially issued	4 September 2020
Remark	This revision replaces the earlier versions, including its documentation folder.
	<p>Further properties are described in the annexes:</p> <ul style="list-style-type: none"> - Description T11741 revision 1; - Documentation folder T11741-2.

Issuing Authority **NMi Certin B.V., Notified Body number 0122**
4 May 2023

Certification Board

NMi Certin B.V.
Thijsseweg 11
2629 JA Delft
The Netherlands
T +31 88 636 2332
certin@nmi.nl
www.nmi.nl



This document is issued under the provision that no liability is accepted and that the manufacturer shall indemnify third-party liability.

The designation of NMI Certin B.V. as Notified Body can be verified at <http://ec.europa.eu/growth/tools-databases/handof>

Reproduction of the complete document only is permitted.

This document is digitally signed and sealed. The digital signature can be verified in the blue ribbon at the top of the electronic version of this certificate.



		<h2>IECEX Certificate of Conformity</h2>	
<p>INTERNATIONAL ELECTROTECHNICAL COMMISSION IEC Certification System for Explosive Atmospheres for rules and details of the IECEX Scheme visit www.iecex.com</p>			
Certificate No.:	IECEX TUN 18.0009X	Page 1 of 4	<u>Certificate history:</u>
Status:	Current	Issue No: 3	Issue 2 (2020-12-09) Issue 1 (2019-03-15) Issue 0 (2018-07-25)
Date of Issue:	2022-12-12		
Applicant:	RMG Messtechnik GmbH Otto-Hahn-Straße 5 35510 Butzbach Germany		
Equipment:	Electronic gas value corrector TME400 type VC, VM, VCF, VMF		
Optional accessory:	associated connection head		
Type of Protection:	Intrinsic Safety "I"		
Marking:	Ex ia IIC T4 Gb		
<p>Approved for issue on behalf of the IECEX Certification Body:</p>		<p>Andreas Meyer</p>	
<p>Position:</p>		<p>Deputy Head of the IECEX Certification Body</p>	
<p>Signature: (for printed version)</p>			
<p>Date: (for printed version)</p>			
<p>1. This certificate and schedule may only be reproduced in full. 2. This certificate is not transferable and remains the property of the issuing body. 3. The Status and authenticity of this certificate may be verified by visiting www.iecex.com or use of this QR Code.</p>			
<p>Certificate issued by:</p> <p>TÜV NORD CERT GmbH Hanover Office Am TÜV 1, 30519 Hannover Germany</p>			

140



IECEX Certificate of Conformity

Certificate No.:	IECEX TUN 18.0009X	Page 2 of 4
Date of issue:	2022-12-12	Issue No: 3
Manufacturer:	RMG Otto-Hahn-Straße 5 35510 Butzbach Germany	
Manufacturing locations:	RMG Otto-Hahn-Straße 5 35510 Butzbach Germany	

This certificate is issued as verification that a sample(s), representative of production, was assessed and tested and found to comply with the IEC Standard list below and that the manufacturer's quality system, relating to the Ex products covered by this certificate, was assessed and found to comply with the IECEX Quality system requirements. This certificate is granted subject to the conditions as set out in IECEX Scheme Rules, IECEX 02 and Operational Documents as amended

STANDARDS :
 The equipment and any acceptable variations to it specified in the schedule of this certificate and the identified documents, was found to comply with the following standards

IEC 60079-0:2017 Edition:7.0	Explosive atmospheres - Part 0: Equipment - General requirements
IEC 60079-11:2011 Edition:6.0	Explosive atmospheres - Part 11: Equipment protection by intrinsic safety "I"

This Certificate does not indicate compliance with safety and performance requirements other than those expressly included in the Standards listed above.

TEST & ASSESSMENT REPORTS:
 A sample(s) of the equipment listed has successfully met the examination and test requirements as recorded in:

Test Report:
[DE/TUN/ExTR18.0018/03](#)

Quality Assessment Report:
[DE/BVS/QAR08.0011/10](#)



IECEX Certificate of Conformity

Certificate No.:	IECEX TUN 18.0009X	Page 3 of 4
Date of issue:	2022-12-12	Issue No: 3

EQUIPMENT:
Equipment and systems covered by this Certificate are as follows:

Description of product:

The electronic gas value corrector TME400 type VC, VM, VCF, VMF is an apparatus for use in gas explosion hazardous areas. It is used for gas measuring, control and regulating purposes by detection of pressure, temperature and volume pulses.

Type code:

Electronic gas value corrector TME 400 type VC, VM, VCF,VMF

Electrical data:

See attachment for IECEX TUN 18.0009X issue 03.

Thermal data:

Ambient temperature range: -25 °C ≤ Ta ≤ +55 °C

SPECIFIC CONDITIONS OF USE: YES as shown below:

1. Electrostatic charge has to be avoided for all housing parts (TME400 and optional associated connection head). The warning label has to be observed.
2. The earth terminal (TME400 and optional associated connection head) has to be connected with the potential equalization in the explosion hazardous area.

141

	<h2>IECEX Certificate of Conformity</h2>
Certificate No.: IECEX TUN 18.0009X	Page 4 of 4
Date of issue: 2022-12-12	Issue No: 3
DETAILS OF CERTIFICATE CHANGES (for issues 1 and above)	
<ul style="list-style-type: none">• Adding an alternative controller type EFM32GG880 (D10). The controller is not an Ex relevant component.• The modification of C26 and C29 has already been taken into account in the issue 02	
The conformity of the TME 400 electronic gas volume corrector type VC, VM, VCF, VMF with the current version of the IEC 60079-0:2017 and the IEC 60079-11:2011 standard has already been confirmed in the previous issue.	
Annex:	
Attachment to IECEX TUN 18.0009X issue 03.pdf	

TÜV NORD CERT GmbH
 Hannover Office
 Am TÜV 1
 30519 Hannover
 Germany



General product information:

Description of product:

The electronic gas value corrector TME 400 type VC, VM, VCF,VMF is an apparatus for use in gas explosion hazardous areas. It is used for gas measuring, control and regulating purposes by detection of pressure, temperature and volume pulses.

Type code:

Electronic gas value corrector TME 400 type VC, VM, VCF,VMF

Electrical data:

Supply circuit
 (Terminal X6; 2 and 3)

in type of protection Intrinsic Safety Ex ia IIC
 Only for connection to a certified intrinsically safe circuit
 Maximum values:
 $U_i = 10.7 \text{ V}$
 $I_i = 219 \text{ mA}$
 $P_i = 325 \text{ mW}$
 Effective internal capacitance: $C_i = 7 \text{ nF}$
 Effective internal inductance: $L_i = 300 \mu\text{H}$

Supply circuit battery, internal
 (Plug connector X12; 1 and 2)

connection to internal battery Saft, type LS33600, 17 Ah or XENO, type XL 205-F, 19 Ah

Signal input
 (Terminals X6; 4 and 5)

in type of protection Intrinsic Safety Ex ia IIC
 Maximum values:
 $U_o = 5.9 \text{ V}$
 $I_o = 3 \text{ mA}$
 $P_o = 5 \text{ mW}$
 Characteristic line: linear

Ex ia	IIC		
max. permissible external inductance	200 μH	100 μH	50 μH
max. permissible external capacitance	4100 nF	5000 nF	6200 nF

RS 485 and signal input
 (Terminals X6; 6 and 7)

in type of protection Intrinsic Safety Ex ia IIC
 Maximum values:
 $U_o = 5.9 \text{ V}$
 $I_o = 60 \text{ mA}$
 $P_o = 88 \text{ mW}$
 Characteristic line: linear

Ex ia	IIC		
max. permissible external inductance	1700 μH	700 μH	200 μH
max. permissible external capacitance	2100 nF	2600 nF	3100 nF

TÜV NORD CERT GmbH
 Hannover Office
 Am TÜV 1
 30519 Hannover
 Germany



Page 2 of 4
 Attachment to IECEx TUN 18.0009X issue No.: 3

RS 485 and signal input
 (Terminals X6; 6 and 7)

in type of protection Intrinsic Safety Ex ia IIC
 Only for connection to a certified intrinsically safe circuit
 Maximum values:
 $U_i = 10.7 \text{ V}$
 $I_i = 219 \text{ mA}$
 $P_i = 325 \text{ mW}$
 Effective internal capacitance: $C_i = 2.1 \text{ nF}$
 Effective internal inductance: $L_i = 300 \text{ }\mu\text{H}$

Pulse output
 (Terminals X3; 1 ... 6)

in type of protection Intrinsic Safety Ex ia IIC
 Maximum values:
 $U_o = 5.9 \text{ V}$
 $I_o = 2 \text{ mA}$
 $P_o = 3 \text{ mW}$

Ex ia	IIC		
max. permissible external inductance	200 μH	100 μH	50 μH
max. permissible external capacitance	4100 nF	5000 nF	6200 nF

Pulse output
 (Terminals X3; 1 ... 6)

in type of protection Intrinsic Safety Ex ia IIC
 Only for connection to a certified intrinsically safe circuit
 Maximum values:
 $U_i = 30 \text{ V}$
 $I_i = 120 \text{ mA}$
 $P_i = 1.2 \text{ W}$
 Effective internal capacitance: $C_i = 3 \text{ nF}$
 The effective internal inductance is negligibly small.

Current output
 (Terminals X9; 1 and 2)

in type of protection Intrinsic Safety Ex ia IIC
 Only for connection to a certified intrinsically safe circuit
 Maximum values:
 $U_i = 28 \text{ V}$
 $I_i = 110 \text{ mA}$
 $P_i = 805 \text{ mW}$
 Effective internal capacitance: $C_i = 2 \text{ nF}$
 Effective internal inductance: $L_i = 300 \text{ }\mu\text{H}$

Optional pulse output
 (Terminals X9; 1 and 2)

in type of protection Intrinsic Safety Ex ia IIC
 Maximum values:
 $U_o = 5.9 \text{ V}$
 $I_o = 1 \text{ mA}$
 $P_o = 1 \text{ mW}$

Ex ia	IIC		
max. permissible external inductance	200 μH	100 μH	50 μH
max. permissible external capacitance	4100 nF	5000 nF	6200 nF

TÜV NORD CERT GmbH
 Hannover Office
 Am TÜV 1
 30519 Hannover
 Germany



Page 3 of 4
 Attachment to IECEx TUN 18.0009X issue No.: 3

Impulse input Reed/Wiegand, internal (Terminals X5; 1 ... 4) in type of protection Intrinsic Safety Ex ia IIC
 Maximum values:
 $U_o = 5.9 \text{ V}$
 $I_o = 6 \text{ mA}$
 $P_o = 8 \text{ mW}$
 Characteristic line: linear

Ex ia	IIC		
max. permissible external inductance	20000 μH	10000 μH	5000 μH
max. permissible external capacitance	1800 nF	1900 nF	2100 nF

Pressure sensor circuit, internal (Terminals X8; 1 ... 4) in type of protection Intrinsic Safety Ex ia IIC
 Maximum values:
 $U_o = 5.9 \text{ V}$
 $I_o = 100 \text{ mA}$
 $P_o = 148 \text{ mW}$
 Characteristic line: linear

Ex ia	IIC	
max. permissible external inductance	30 μH	25 μH
max. permissible external capacitance	4100 nF	2000 nF
Sensor	UTC30	TI-1

Pt1000 temperature input, internal (Terminals X11; 1 and 2) in type of protection Intrinsic Safety Ex ia IIC
 Maximum values:
 $U_o = 5.9 \text{ V}$
 $I_o = 9 \text{ mA}$
 $P_o = 13 \text{ mW}$
 Characteristic line: linear

Ex ia	IIC		
max. permissible external inductance	500 μH	200 μH	100 μH
max. permissible external capacitance	3200 nF	4000 nF	4900 nF

All maximum values L_o and C_o are also allowed to be utilized as concentrated capacitances and as concentrated inductances.

For safety reasons, all intrinsically safe circuits are galvanically interconnected with each other via GND potential and safely galvanically separated from earth potential.

At interconnection of intrinsically safe circuits, the rules for interconnection of intrinsically safe circuits have to be observed.

Thermal data:

Ambient temperature range: $-25 \text{ }^\circ\text{C} \leq T_a \leq +55 \text{ }^\circ\text{C}$

TÜV NORD CERT GmbH
Hannover Office
Am TÜV 1
30519 Hannover
Germany



Page 4 of 4
Attachment to IECEx TUN 18.0009X issue No.: 3

Details of Change:

- ☒ Adding an alternative controller type EFM32GG880 (D10). The controller is not an Ex relevant component.
- ☒ The modification of C26 and C29 has already been taken into account in the issue 02

The conformity of the TME 400 electronic gas volume corrector type VC, VM, VCF, VMF with the current version of the IEC 60079-0:2017 and the IEC 60079-11:2011 standard has already been confirmed in the previous issue.

Specific Conditions of Use

1. Electrostatic charge has to be avoided for all housing parts (TME400 and optional associated connection head). The warning label has to be observed.
2. The earth terminal has to be connected with the potential equalization in the explosion hazardous area (TME400 and optional associated connection head).



(13) **SCHEDULE**

(14) **EU-Type Examination Certificate TÜV 17 ATEX 207566 X Issue 03**

(15) **Description of product**

Description:

The electronic gas value corrector TME 400 type VC, VM, VCF,VMF is an apparatus for use in gas explosion hazardous areas.
It is used for gas measuring, control and regulating purposes by detection of pressure, temperature and volume pulses.

Type code:

Electronic gas value corrector TME 400 type VC, VM, VCF,VMF

Electrical data:

Supply circuit (Terminal X6; 2 and 3)	In type of protection Intrinsic Safety Ex ia IIC Only for connection to a certified intrinsically safe circuit Maximum values: U _i = 10.7 V I _i = 219 mA P _i = 325 mW Effective internal capacitance: C _i = 7 nF Effective internal inductance: L _i = 300 µH
Supply circuit battery, internal (Plug connector X12; 1 and 2)	Connection to internal battery Saft, type LS33600, 17 Ah or XENO, type XL 205-F, 19 Ah
Signal input (Terminals X6; 4 and 5)	In type of protection Intrinsic Safety Ex ia IIC Maximum values: U _o = 5.9 V I _o = 3 mA P _o = 5 mW Characteristic line: linear

Ex ia	IIC		
max. permissible external inductance	200 µH	100 µH	50 µH
max. permissible external capacitance	4100 nF	5000 nF	6200 nF

RS 485 and signal input (Terminals X6; 6 and 7)	In type of protection Intrinsic Safety Ex ia IIC Maximum values: U _o = 5.9 V I _o = 60 mA P _o = 88 mW Characteristic line: linear
--	--

Ex ia	IIC		
max. permissible external inductance	1700 µH	700 µH	200 µH
max. permissible external capacitance	2100 nF	2600 nF	3100 nF

This certificate may only be reproduced without any change, schedule included.
Excerpts or changes shall be allowed by the TÜV NORD CERT GmbH



Schedule to EU-Type Examination Certificate TÜV 17 ATEX 207566 X Issue 03

RS 485 and signal input
(Terminals X6; 6 and 7)

In type of protection Intrinsic Safety Ex ia IIC
Only for connection to a certified intrinsically safe circuit
Maximum values:
U_i = 10.7 V
I_i = 219 mA
P_i = 325 mW
Effective internal capacitance: C_i = 2.1 nF
Effective internal inductance: L_i = 300 µH

Pulse output
(Terminals X3; 1 ... 6)

In type of protection Intrinsic Safety Ex ia IIC
Maximum values:
U_o = 5.9 V
I_o = 2 mA
P_o = 3 mW

Ex ia	IIC		
max. permissible external inductance	200 µH	100 µH	50 µH
max. permissible external capacitance	4100 nF	5000 nF	6200 nF

Pulse output
(Terminals X3; 1 ... 6)

In type of protection Intrinsic Safety Ex ia IIC
Only for connection to a certified intrinsically safe circuit
Maximum values:
U_i = 30 V
I_i = 120 mA
P_i = 1.2 W
Effective internal capacitance: C_i = 3 nF
The effective internal inductance is negligibly small.

Current output
(Terminals X9; 1 and 2)

In type of protection Intrinsic Safety Ex ia IIC
Only for connection to a certified intrinsically safe circuit
Maximum values:
U_i = 28 V
I_i = 110 mA
P_i = 805 mW
Effective internal capacitance: C_i = 2 nF
Effective internal inductance: L_i = 300 µH

Optional pulse output
(Terminals X9; 1 and 2)

In type of protection Intrinsic Safety Ex ia IIC
Maximum values:
U_o = 5.9 V
I_o = 1 mA
P_o = 1 mW

Ex ia	IIC		
max. permissible external inductance	200 µH	100 µH	50 µH
max. permissible external capacitance	4100 nF	5000 nF	6200 nF

This certificate may only be reproduced without any change, schedule included.
Excerpts or changes shall be allowed by the TÜV NORD CERT GmbH



Schedule to EU-Type Examination Certificate TÜV 17 ATEX 207566 X Issue 03

Impulse input Reed/Wiegand, internal
(Terminals X5; 1 ... 4)

In type of protection Intrinsic Safety Ex ia IIC
Maximum values:
U_o = 5.9 V
I_o = 6 mA
P_o = 8 mW
Characteristic line: linear

Ex ia	IIC		
max. permissible external inductance	20000 µH	10000 µH	5000 µH
max. permissible external capacitance	1800 nF	1900 nF	2100 nF

Pressure sensor circuit, internal
(Terminals X8; 1 ... 4)

In type of protection Intrinsic Safety Ex ia IIC
Maximum values:
U_o = 5.9 V
I_o = 100 mA
P_o = 148 mW
Characteristic line: linear

Ex ia	IIC	
max. permissible external inductance	30 µH	25 µH
max. permissible external capacitance	4100 nF	2000 nF
Sensor	UTC30	TI-1

Pt1000 temperature input, internal
(Terminals X11; 1 and 2)

In type of protection Intrinsic Safety Ex ia IIC
Maximum values:
U_o = 5.9 V
I_o = 9 mA
P_o = 13 mW
Characteristic line: linear

Ex ia	IIC		
max. permissible external inductance	500 µH	200 µH	100 µH
max. permissible external capacitance	3200 nF	4000 nF	4900 nF

All maximum values L_o and C_o are also allowed to be utilized as concentrated capacitances and as concentrated inductances.

For safety reasons, all intrinsically safe circuits are galvanically interconnected with each other via GND potential and safely galvanically separated from earth potential.

At interconnection of intrinsically safe circuits, the rules for interconnection of intrinsically safe circuits have to be observed.

Thermal data:

Ambient temperature range: -25 °C ≤ Ta ≤ +55 °C

(16) Drawings and documents are listed in the ATEX Assessment Report No. 22 203 325538

This certificate may only be reproduced without any change, schedule included.
Excerpts or changes shall be allowed by the TÜV NORD CERT GmbH



Schedule to EU-Type Examination Certificate TÜV 17 ATEX 207566 X Issue 03

(17) Specific Conditions for Use

1. Electrostatic charge has to be avoided for all housing parts (TME400 and optional associated connection head). The warning label has to be observed.
2. The earth terminal has to be connected with the potential equalization in the explosion hazardous area (TME400 and optional associated connection head).

(18) Essential Health and Safety Requirements

no additional ones

- End of EU-Type Examination Certificate -

This certificate may only be reproduced without any change, schedule included.
Excerpts or changes shall be allowed by the TÜV NORD CERT GmbH



CERTIFICATE

for a management system as per

Pressure Equipment Directive 2014/68/EU Module D

Evidence of conformity has been furnished.



ONE STEP AHEAD

RMG Messtechnik GmbH
Otto-Hahn-Straße 5
35510 Butzbach
Germany

scope:

Production of gas meters and
associated items of equipment

Certificate registration No. **73 202 2839**

Certificate valid from 2021-07-26 to **2024-07-15**

Audit report No. 4383 6173



ZLS
ZLS-NB-0223

Darmstadt, 2021-07-26
Certification body of TÜV Hessen
- Head of Certification body -

PAGE 1 OF 1.

*previous certificate was valid until 2021-07-15

This certification confirms the introduction and maintenance of the Management system specified above and is monitored regularly. The manufacturer is entitled to provide in the context of the scope of pressure equipment devices with CE-marking with the identification number 0091 of the notified body of TÜV Hessen. The current validity is verifiable at www.proficert.com. Original certificates contain a glued hologram.

TÜV Technische Überwachung Hessen GmbH, Robert-Bosch-Strasse 16, D-64293 Darmstadt, Germany; Phone +49 6151/600331 Rev.-GB-2007

TÜV Technische Überwachung Hessen GmbH

Industrie Service
Hans – Böckler – Straße 4
Telefon: 06403 / 9008 – 0

35440 Linden
Fax: 06403 / 9008 - 20



ZERTIFIKAT

(EU-BAUMUSTERPRÜFBESCHEINIGUNG FÜR BAUMUSTER)
(EU-type examination certificate – production type)

EU-Baumusterprüfung (Modul B für Baumuster) nach Richtlinie 2014/68/EU
EU-type examination (Module B - production type) according to directive 2014/68/EU

Zertifikat – Nr.: ISG-22-22-1097_Rev. 01

Name und Anschrift des Herstellers: **RMG Messtechnik GmbH**
Otto-Hahn-Strasse 5
Name and postal address of the manufacturer: **D-35510 Butzbach**

Hiermit wird bestätigt, dass das unten genannte Baumuster die Anforderungen der Richtlinie 2014/68/EU erfüllt.
We herewith certify that the type mentioned below meets the requirements of the directive 2014/68/EU.

Prüfbericht – Nr.: siehe Beiblätter zu/ see attached sheet: ISG-22-22-1097_Rev. 01
Test report No.:

Bezeichnung: Turbinradgaszähler TME400-VMF /-VCF
Designation: DN50, DN80, DN100, DN150, DN200

Geltungsbereich: **Turbinradgaszähler TME400-VMF / -VCF**
Scope of examination: siehe Beiblätter zu/ see attached sheet to: ISG-22-22-1097_Rev. 01

Prüfobjekt: druckhalt. Ausrüstungsteil (pressure accessory)
Inspection item:

Kategorie: I - IV
Category:

Fertigungsstätte: Otto-Hahn-Str. 5, D-35510 Butzbach
Manufacturing plant:

Gültig bis: siehe Beiblätter zu/ see attached sheets to: ISG-22-22-1097_Rev. 01
Valid:

Bemerkungen / Hinweise: Die Zertifikate ISG-22-22-1097_Rev.-- vom 03.11.2022 und ISG22-12-1978 Rev. F vom 27.11.2019 sind hiermit ersetzt und verlieren ihre Gültigkeit / The certificates ISG-22-22-1097_Rev. -- dated 03.11.2022 and ISG-22-12-1978 Rev. F dated 27.11.2019 thier hereby replaced and loses thier validity!
Remarks / hints: Die zulässigen Einsatztemperaturen und die zugelassenen Materialien der Turbinradgaszähler sind der Entwurfsprüfung des Baumuster zu entnehmen. / The permitted operating temperatures and the permitted materials of the turbine wheel

Anlagen: siehe Beiblatt zu/ see attached sheet to: TÜV Technische Überwachung Hessen GmbH
documents: ISG-22-22-1097_Rev. 01 **Notified body, No.: 0091**

Linden, 10.01.2023
place, date **Zertifizierer:**



[Handwritten Signature]

E. Dietrich S. Droß

Umseitige Hinweise beachten / see hints overleaf

ISG_22_22-1097_REV_01__RMG_B+B_TME400-VMF +VCF.Docx

1 **Production Quality Assurance Notification**

2 Equipment and Protective Systems intended for use in potentially explosive atmospheres
 Directive 2014/34/EU
 Annex IV - Module D: Conformity to type based on quality assurance of the production process
 Annex VII - Module E: Conformity to type based on product quality assurance

3 Notification number: **BVS 20 ATEX ZQS/E139**

4 Product category: **Equipment and components
 equipment-group II, category 2G: Manufacturing and sale of Volume Meters,
 Electronic Correctors and Gas Analysers, Electrical equipment and devices**

ONE STEP AHEAD

5 Manufacturer: **RMG Messtechnik GmbH**

6 Address: **Otto-Hahn-Strasse 5, 35510 Butzbach, Germany**

Site(s) of manufacture: **RMG Messtechnik GmbH, Otto-Hahn-Strasse 5, 35510 Butzbach, Germany
 RMG Messtechnik GmbH, Heinrich-Lanz-Strasse 9, 67259 Beindersheim, Germany**

7 The certification body of DEKRA Testing and Certification GmbH, Notified Body No 0158 in accordance with Article 17 of the Council Directive 2014/34/EU of 26 February 2014 notifies that the manufacturer has a production quality system, which complies with Annex IV of the Directive. This quality system in compliance with Annex IV of the Directive also meets the requirements of Annex VII. In the updated annex all products covered by this notification and their type examination certificate numbers are listed.

8 This notification is based on audit report ZQS/E139/20 issued 2020-11-20. Results of periodical re-assessments of the quality system are a part of this notification.

9 This notification is valid from 2020-10-28 until 2023-10-28 and can be withdrawn if the manufacturer does not satisfy the production quality assurance surveillance according to Annex IV and VII.

10 According to Article 16 (3) of the Directive 2014/34/EU the CE marking shall be followed by the identification number 0158 of DEKRA Testing and Certification GmbH as notified body involved in the production control phase.

DEKRA Testing and Certification GmbH
 Bochum, 2020-11-20

Managing Director

This is a translation from the German original.
 In the case of arbitration only the German wording shall be valid and binding.

Page 1 of 1 - Jobnumber 342009000
 This notification may only be reproduced in its entirety and without any change.
 DEKRA Testing and Certification GmbH, Handwerkstr. 15, 70565 Stuttgart, Germany
 Certification body: Dinnendahlstr. 9, 44809 Bochum, Germany
 Phone +49.234.3696-400, Fax +49.234.3696-401, e-mail DTC-Certification-body@dekra.com



Physikalisch-Technische Bundesanstalt
Nationales Metrologieinstitut

KBS

Konformitätsbewertungsstelle

155



Zertifikat
Certificate

über die Anerkennung eines Qualitätssicherungssystems
on the approval of a quality system

Ausgestellt für: RMG Messtechnik GmbH
Issued to: Otto-Hahn-Str. 5
35510 Butzbach

gemäß: Mess- und Eichverordnung vom 11. Dezember 2014 (MessEV)
In accordance with: Measures and Verification Ordinance dated 11 December 2014 (MessEV)
in Verbindung mit
in connection with

- Richtlinie **2014/32/EU** vom 26. Februar 2014 (MID)
- Directive **2014/32/EU** of 26 February 2014 (MID)

Messgröße lt. MessEV § 1: Volumen
Measurand acc. to Measures and Verification Ordinance, section 1: Volume
Sonstige Messgrößen bei der Lieferung von strömenden Flüssigkeiten oder strömenden Gasen
Other measurands in the supply of flowing liquids or flowing gases

Nr. des Zertifikats: DE-M-AQ-PTB023, Revision 5
Certificate No.:

Gültig bis: 08.02.2027
Valid until:

Anzahl der Seiten: 6
Number of pages:

Geschäftszeichen: PTB-9.22-4116650
Reference No.:

Nr. der Stelle: 0102
Body No.:

Im Auftrag
On behalf of PTB

Markus Umer

Braunschweig, 09.02.2024

Siegel
Seal



RS-027579



Translation

(1) **EU-Type Examination Certificate**

- (2) Equipment and protective systems intended for use in potentially explosive atmospheres, **Directive 2014/34/EU**



- (3) **Certificate Number** TÜV 17 ATEX 207696 **issue:** 00
- (4) for the product: Isolating Amplifier type Ex 400
- (5) of the manufacturer: RMG Messtechnik GmbH
- (6) Address: Otto-Hahn-Straße 5
35510 Butzbach
- Order number: 8000476312
- Date of issue: 2019-09-16

- (7) The design of this product and any acceptable variation thereto are specified in the schedule to this EU-Type Examination Certificate and the documents therein referred to.
- (8) The TÜV NORD CERT GmbH, Notified Body No. 0044, in accordance with Article 17 of the Directive 2014/34/EU of the European Parliament and the Council of 26 February 2014, certifies that this product has been found to comply with the Essential Health and Safety Requirements relating to the design and construction of products intended for use in potentially explosive atmospheres given in Annex II to the Directive.
The examination and test results are recorded in the confidential ATEX Assessment Report No. 19 203 207696.
- (9) Compliance with the Essential Health and Safety Requirements has been assured by compliance with:
EN 60079-0:2012+A11:2013 EN 60079-11:2012
except in respect of those requirements listed at item 18 of the schedule.
- (10) If the sign "X" is placed after the certificate number, it indicates that the product is subject to the Specific Conditions for Use specified in the schedule to this certificate.
- (11) This EU-Type Examination Certificate relates only to the design, and construction of the specified product. Further requirements of the Directive apply to the manufacturing process and supply of this equipment. These are not covered by this certificate.
- (12) The marking of the product shall include the following:

II (2) G [Ex ia Gb] IIC

TÜV NORD CERT GmbH, Langemarckstraße 20, 45141 Essen, notified by the central office of the countries for safety engineering (ZLS), Ident. Nr. 0044, legal successor of the TÜV NORD CERT GmbH & Co. KG Ident. Nr. 0032

The head of the notified body

Röder

Hanover office, Am TÜV 1, 30519 Hannover, Tel. +49 511 998-61455, Fax +49 511 998-61590

This certificate may only be reproduced without any change, schedule included.
Excerpts or changes shall be allowed by the TÜV NORD CERT GmbH

Subject to technical changes

More information

If you would like to learn more about the products and solutions from RMG, visit our website:

www.rmg.com

or contact your local sales representative

RMG Messtechnik GmbH

Otto-Hahn-Straße 5

35510 Butzbach, Germany

Phone: +49 (0) 6033 897 – 0

Fax: +49 (0) 6033 897 – 130

Email: service@rmg.com