



Operating Manual

Turbine Meter TME400-VC (..-VCF)

Issued: 2022 November 30th
Version: 10
Firmware: 1.12 / 11.12

Manufacturer Contact our customer service department for technical information.

Address	RMG Messtechnik GmbH Otto-Hahn-Straße 5 D-35510 Butzbach (Germany)
Main office	+49 6033 897 – 0
Service	+49 6033 897 – 897
Spare parts	+49 6033 897 – 173
Fax	+49 6033 897 – 130
Email	service@rmg.com



You can register your product on our website at <https://www.rmg.com/en/help/device-registration>.
By this you are helping us to improve our support

Translation of the original document

The manual **TME400VCF_manual_en_10** of 2022 November 30th for the TME400-VC and TME400-VCF turbine meter with volume converters is a translation of the original German document **TME400VCF_manual_de_10**.

Note Unfortunately, paper is not updated automatically, whereas technical development continuously advances. Therefore, we reserve the right to make technical changes in regard to the representations and specifications of these operating instructions. The latest version of this manual (and other devices) can be downloaded at your convenience from our Internet page:

www.rmg.com.

Created	June 2018
7th Revision	July 2021
8th Revision	March 2022
9th Revision	2022 November 30th

Document version and language	Document version	TME400VCF_manual_en_10 2022 November 30th
	Language	EN

TABLE OF CONTENTS

1	INTRODUCTION	1
1.1	STRUCTURE OF THE MANUAL.....	1
1.2	PURPOSE OF THE MANUAL.....	2
1.2.1	<i>Abbreviations</i>	2
1.2.2	<i>Symbols</i>	3
1.2.3	<i>Structure of notices</i>	3
1.2.4	<i>Working with the device</i>	4
1.2.5	<i>Risk assessment and minimization</i>	9
1.2.6	<i>Applicability of the manual</i>	12
1.2.7	<i>Transport</i>	13
1.2.8	<i>Scope of delivery</i>	14
1.2.9	<i>Storage</i>	15
1.2.10	<i>Disposal</i>	15
1.3	OVERVIEW OF VERSIONS	16
1.3.1	<i>Description</i>	16
1.3.2	<i>Device features</i>	16
1.3.3	<i>Firmware</i>	17
1.3.4	<i>Power supply</i>	17
1.3.5	<i>Area of application</i>	18
1.3.6	<i>Use of gas meters for different gases</i>	20
1.4	AREAS OF APPLICATION	22
1.4.1	<i>Working principle of the TME400</i>	22
1.4.2	<i>Integrating the turbine meter into the pipeline</i>	24
2	INSTALLATION	39
2.1	ELECTRICAL CONNECTIONS.....	39
3	TME400	50
3.1	DISPLAY FIELD	50
3.1.1	<i>Display test</i>	51
3.1.2	<i>Reset</i>	51
3.1.3	<i>Booting up</i>	52
3.1.4	<i>Battery replacement</i>	54
4	OPERATION	57
4.1	OPERATION CONCEPT	57
4.1.1	<i>Coordinate system</i>	57
4.1.2	<i>Display and coordinate system</i>	59
4.1.3	<i>Parameter protection</i>	59
4.2	PROGRAMMING	61
4.2.1	<i>Programming with the programming buttons</i>	61
4.3	EQUATIONS IN THE TME400.....	64
4.3.1	<i>Variable description</i>	64
4.3.2	<i>Standard formula</i>	65
4.3.3	<i>Coordinates in context</i>	65

4.4	SPECIAL SETTINGS	85
4.4.1	<i>Configuration of the current output</i>	85
4.5	RMGVIEW ^{TME}	86
5	TECHNICAL DATA	87
5.1.1	<i>Device types</i>	87
5.1.2	<i>Inputs</i>	87
5.1.3	<i>Outputs</i>	89
5.1.4	<i>Digital interface</i>	89
5.1.5	<i>Current loop connection</i>	89
5.1.6	<i>Cable</i>	91
5.1.7	<i>Cable connection</i>	91
5.1.8	<i>Ground</i>	93
5.2	OVERVIEW OF MATERIALS IN USE	95
6	ERROR MESSAGES	96
	APPENDIX	98
A	MODBUS	98
B	STRUCTURE OF THE ARCHIVES	108
B1	ARCHIVE SIZE	108
B2	ARCHIVE TYPES	108
B2.1	PARAMETER ARCHIVES	109
B2.2	EVENT ARCHIVES	109
B2.3	MEASURED VALUES ARCHIVES	110
B3	CALCULATION OF THE STORAGE SIZE	111
B4	ARCHIVE HEADER	111
B5	READING THE ARCHIVE DATA VIA MODBUS	114
C	DIMENSIONS	116
D	MEASURING RANGES FOR TME 400-VMF/ TME 400-VCF	121
E	MEASURING ACCURACY FOR TME 400-VC	122
F	TYPE PLATE	124
G	SEAL DIAGRAMS	126
H	LATER INSTALLATION OF THE POWER MODULE	127
I	SPARE PARTS AND ACCESSORIES	129
J	CERTIFICATES AND APPROVALS	142

1 Introduction

1.1 Structure of the manual

The introduction of this manual comprises two parts. The first part lists general specifications; the symbols used in the manual and the structure of notices are presented and a risk assessment is provided. The differences between the TME400-VC and TME400-VCF turbine meters with volume converters are explained. If there is no explicit reference to differences, the TME400 is superordinate for both versions.

Note

The unit of the turbine meter is always identified with an electric converter with TME400-VC and TME400-VCF in this manual.

In addition, the first part includes specifications for the transport and storage of the TME400. The second part of the introduction describes the features and areas of application of the TME400; basic standards are listed and the pressure and temperature ranges in which the TME400 can and may be used are pre-adjusted.

The second chapter describes the electrical and mechanical commissioning of the TME400. An explanation of how to achieve the reliable commissioning of the meter and high precision is provided.

The third chapter explains the displays of the TME400. It explains resetting, booting and replacement of the battery.

The settings of the TME400 are explained in chapter four. In particular, all adjustable parameters are provided there with some explanations.

The fifth chapter summarizes the technical data and the sixth chapter provides a list of error messages.

The appendix provides details about the Modbus, measurements, type plate and seal plans. Then the certificates and approvals are listed.

1.2 Purpose of the manual

This manual provides information that is necessary for fault-free and safe operation.

The TME400 was designed and produced according to the state of the art and generally recognized safety standards and directives. However, its use can entail dangers that are avoidable by complying with this manual. The device must only be used as intended and in technically sound condition.

Warning

Unintended use voids all warranty claims and the TME400 can also lose its approvals.

1.2.1 Abbreviations

The following abbreviations are used:

TME400-VM	The TME400-VM is a turbine meter which is used for non-custody-transfer volume measurement (V olume M easurement) of the operating volume of non-aggressive gases and combustion fuels is used.
TME400-VMF	The TME400-VMF is a turbine meter that is used in custody-transfer applications (F iscally). The designation TME400-VMF comprises all turbine meters.
TME400-VC	The TME400-VC also enables calculation of the standard volume flow (V olume C orrector) from the operating volume flow in non-custody-transfer applications.
TME400-VCF	The TME400-VCF is used in custody-transfer applications (F iscally). In addition to the turbine meter, the TME400-VCF designation also includes the volume corrector.

Note

This manual only describes the TME400-VC and TME400-VCF.

MessEG	Measurement and Calibration Act Law on the marketing and provision of measuring devices in the market, their use and calibration, valid since 1/1/2015
MessEV	Measurement and Calibration Regulation Regulation on the marketing and provision of measuring devices in the market and on their use and calibration; 12/11/2014
MID	Measurement Instruments Directive
PTB	Physikalisch-Technische Bundesanstalt [German National Test Authority]
Vo	<u>o</u> riginal meter reading (<u>V</u> olume) of a mechanical counter
approx.	approximately
max.	maximum
min.	minimum

3

1.2.2 Symbols

The following symbols are used:

1, 2, ...	Identifies steps for work tasks
..	

1.2.3 Structure of notices

The following notices are used:

 **Danger**

This warning notice informs you of imminently threatening dangers that can arise due to misuse/operator error. If these situations are not avoided, death or severe injuries can occur.

⚠ Warning

This warning notice informs you of potentially dangerous situations that can arise due to misuse/operator error. If these situations are not avoided, minor injuries can occur.

⚠ Caution

This notice informs you of potentially dangerous situations that can arise due to misuse/operator error. If these situations are not avoided, damage to the device or nearby property can occur.

Note

This notice informs you of potentially dangerous situations that can arise due to misuse/operator error. If these situations are not avoided, damage to the device or nearby property can occur.

This notice can provide you with helpful tips to make your work easier. This notice also provides you with further information about the device or the work process in order to prevent operator error.

1.2.4 Working with the device

1.2.4.1 Safety notices Danger, Warning, Caution and Note

⚠ Danger

All of the following safety notices must be observed!

Disregard of the safety notices can result in danger to the life and limb or environmental and property damage.

Bear in mind that the safety warnings in this manual and on the device cannot cover all potentially dangerous situations, because the interaction of various conditions can be impossible to foresee. Merely following the instructions may not suffice for correct operation. Always remain attentive and consider potential consequences.

- Read this operating manual and especially the following safety notices carefully before working with the device for the first time.
- Warnings are provided in the operating manual for unavoidable residual risks for users, third parties, equipment or other property. The safety instructions used in this manual do not refer to unavoidable residual risks.
- Only operate the device in fault-free condition and in observance of the operating manual.
- Compliance with local statutory accident prevention, installation and assembly regulations is also mandatory.

⚠ Caution

All notices in the manual must be observed. Use of the TME400 is only permitted in accordance with the specifications in the operating manual. RMG assumes no liability for damages arising due to disregard of the operating manual.

⚠ Danger

Service and maintenance tasks or repairs that are not described in the operating manual must not be carried out without prior consultation with the manufacturer. The device must not be opened forcefully.

⚠ Caution

The TME400 is approved for custody-transfer applications. For this purpose, it is sealed before deliver and settings specified by the approval authority are locked. These seals, software or hardware locks must not be damaged, destroyed or removed!

In this case, the TME400 loses its official certification!

The TME400 can only be approved for officially certified operation after a renewed inspection by an officially recognized inspection authority or calibration officials and an additional inspection of additional settings. The calibration official must re-apply the seals after the inspection.

Observe the following, in particular:

- Changes to the TME400 are not permitted.
- The technical specifications must be observed and followed for safe operation. Performance limits must not be exceeded (*chapter 5 Technical data*).
- For safe operation, the TME400 must only be used in the scope of the intended use (*chapter 1.3 Overview of versions*).
- The TME400 complies with current standards and regulations. However, danger can arise with misuse.

1.2.4.2 Dangers during commissioning

Initial commissioning

The initial commissioning must only be carried out by specially trained personnel (training by RMG) or RMG service personnel.

Note

An acceptance test certificate must be created during the commissioning. This, the operating manual and the EU Declaration of Conformity must be stored so that they are always readily available.

All sharp edges on the device were removed, insofar as possible. However, personal protective equipment provided by the operator must be worn during all work.

Danger

Install the device as specified in the operating manual. If the device is not installed as specified in the operating manual, there may be a risk that adequate explosion protection is not provided.

The explosion protection is lost!

⚠ Danger

Inadequately qualified persons working on the equipment are unable to correctly estimate dangers. Explosions can be triggered. Only work on the equipment if you have the appropriate qualifications.

Components can be damaged if you do not use suitable tools and materials. Use tools that are recommended for the respective work in the operating manual.

Mechanical installation	Mechanical installation must only be performed by appropriately qualified technicians.
Electrical installation	Installation on electrical components must only be carried out by qualified electricians.
Mechanical and/or electrical installation	These qualified personnel require training specifically for work in hazardous areas. Qualified personnel are persons who have training / education in accordance with DIN VDE 0105, IEC 364 or comparable standards .

⚠ Danger

Installation and removal of the TME400 must only take place in an explosion-free, pressure-free atmosphere. The descriptions in the operating manual must be observed. In general, it is recommended that the replacement should only be carried out by RMG Service.

A leak test must be carried out after work on pressurized components.

All of the above points also apply to repair and maintenance tasks and in general when opening the meter is necessary.

Flange fastening elements, fastening screws, screw couplings and check valves, the oil supply, pressure relief connections, valves, HF pulse generators, protective pipes and swivel adapters must not be loosened during operation.

1.2.4.3 Dangers during maintenance and repair

Operating personnel	The operating personnel use and operate the device in the scope of the intended use.
---------------------	--

Maintenance personnel

Work on the device must only be carried out by qualified personnel who can carry out the respective tasks on the basis of their technical training, experience and familiarity with the applicable standards and requirements. These qualified personnel are familiar with the applicable statutory regulations for accident prevention and can independently recognize and avoid potential dangers.

Maintenance and cleaning

Maintenance and cleaning must only be performed by appropriately qualified technicians.

⚠ Danger

Inadequately qualified persons working on the equipment are unable to correctly estimate dangers. Explosions can be triggered. If work on live equipment must be conducted in hazardous areas, sparks that are created can trigger an explosion.

⚠ Danger

The device can be damaged if it is not cleaned as specified in the operating manual. Only clean the device as specified in the operating manual.

Components can be damaged if you do not use suitable tools. The explosion protection is lost.

- **Only clean the device with a damp cloth!**

⚠ Danger

The TME400 must only be used as intended! (*Chapter 1.3 Overview of versions*). Prevent use of the TME400 as a potential climbing aid or use of attachments of the TME400 as potential handles!

1.2.4.4 Qualification of personnel

Note

In general, the following is recommended for all persons working with or on the TME400:

- Training / education for work in hazardous areas.
- The capacity to be able to correctly estimate dangers and risks when working with the TME400 and all connected devices. Possible dangers include components that are under pressure and consequences of incorrect installation.
- Recognition of dangers that can arise from the flow medium that is used.
- Training / education by RMG for work with gas measuring devices.
- Education / instruction in all national standards and directives to be complied with for the work to be carried out on the device.

1.2.5 Risk assessment and minimization

According to assessment by qualified employees of RMG, the TME400 is subject to risks during its use. Risks can arise, for example, due to high pressures and occasionally due to pressures that are too low. Work outside of the permissible temperature range can also lead to dangers. Impermissible current and voltage values can trigger explosions in hazardous areas. The risk assessment requires an emptying and ventilation of the pipeline for connection with installation and removal of a turbine. Then and only then is it assured that there is not a hazardous gas mixture in the pipeline. Naturally, work must only be carried out by trained personnel (see *chapter 1.2.4.4 Qualification of personnel*), who are also trained to recognize suitable tools and use them exclusively. The risks were summarized alongside development and measures were taken to minimize these risks.

Measures for risk minimization:

- All pressurized parts are designed in accordance with AD 2000 rules and regulations, Pressure Equipment Directive, Annex 1
- The complete pressure design has been inspected by TÜV Hessen
- All pressurized parts have been manufactured with a material certificate; there is an uninterrupted change of batch tracing of pressurized components
- The mechanical properties of all relevant pressurized components have been subjected to tension tests, notch impact bending tests and hardness tests

- Non-destructive testing was also carried out: X-ray and ultrasonic inspection of the meter housing for defective points in material, surface crack testing with magnetic powder and a color penetration process
- Strength tests for components were conducted at 1.5 times the nominal pressure for the pressure testing; the leak testing for the assembly was conducted at 1.1 times the nominal pressure. Certificates were issued for successfully passed tests
- The maximum operating pressure and the permissible temperature range are specified on the type plate of the device. Operation of the device is only permitted within these specified ranges.
- A maximal temperature difference of $\Delta T \leq 100^{\circ}\text{K}$ between the inside and outside of the TME400 must be respected.
- Additional external forces and torques were not taken into account in the pressure dimensioning.
- In the event that the pressure equipment is to be marketed and put into operation as an assembly within the meaning of the Pressure Equipment-Directive, an examination of the assembly must be provided at the latest during the final and pressure tests.
Otherwise, the commissioning inspector must explicitly point out that a test of the equipment location with safety function still has to be performed at the installation site.

⚠ Danger

The following applies for work in hazardous areas (all zones):

- The pulse generators of the turbine meter must be connected to intrinsically safe power circuit only.
- Only tools that are approved for Ex Zone 1 are permitted for maintenance and repair tasks.
- Otherwise, work must only be carried out when there is not an explosive atmosphere.
- The risk of ignition due to impact or friction must be avoided.
- Work on devices which are used in hazardous areas must be carried out by qualified electrical engineers with special capabilities for work in hazardous areas.
- The wiring / installation in hazardous areas must only be carried out by trained personnel in accordance with EN60079-14 and in observance of national regulations.
- Qualified persons must satisfy the definitions in accordance with DIN EN 0105 or IEC 364 or directly comparable standards.
- If one or more power circuits are used, it must be ensured that the permissible limit values according to the EC type approval certificate are not exceeded when choosing the cables.
- Every Ex signal circuit must be routed with a dedicated cable which must be guided through the appropriate PG screw coupling.
- Permanent installation of the intrinsically safe cable is mandatory.

11

⚠ Danger

In addition, the following applies for work in hazardous areas (all zones):

- Only trained and instructed personnel are permitted. Work on the measuring system must only be carried out from qualified persons and inspected by responsible qualified supervisors.
- Qualified persons have been authorized by the person responsible for safety of personnel to carrying out such work on the basis of their training, experience or instruction and familiarity with applicable standards, provisions, accident prevention regulations and system conditions. It is essential that these persons are able to recognize and avoid potential dangers in good time.

1.2.6 Applicability of the manual

This manual describes the TME400. TME400 is generally only part of a complete system. The manuals of the other components of the system must be observed. If you find contradictory instructions, contact RMG and/or the manufacturers of the other components.

Note

Ensure that the power data of the current connection matches the specifications on the type plate. Ensure that the limit values specified in the conformity certificate (see appendix) for the devices to be connected are not exceeded.

Observe any applicable national regulations in the country of use. Use cable that is appropriate for the cable fittings.

Danger

Only work on the equipment if you have the appropriate training and qualifications.

Attention: Risk of destruction due to body electricity, e.g. due to the rubbing of clothing.

1.2.6.1 Danger during operation

Observe the specifications of the system manufacturer and/or system operator.

1.2.6.2 Dangers of operation in EX areas

Only operate the device in fault-free and complete condition.

If you make technical changes to the device, safe operation can no longer be guaranteed.

Danger

Only use the device in its original condition. The TME400 is permitted for operation in Ex Protection Zone 1, but only within the permissible temperature range (*chapter 1.3.5.2 Temperature ranges*).

1.2.6.3 Responsibility of the operator

As the operator, you must ensure that only adequately qualified personnel work on the device. Ensure that all employees who work with the device have read and understood this manual. You are also obligated to train personnel regularly and inform them of the dangers. Ensure that all work on the device is carried out exclusively by qualified persons and inspected by responsible qualified supervisors. The responsibilities for installation, operation, fault rectification, maintenance and cleaning must be clearly regulated. Instruct your personnel with regard to the risks involved with working with the device.

1.2.7 Transport

The device is packaged specific to the transport requirements for each customer. Ensure safe packaging that absorbs light impact and vibrations is used for any further transport. Nevertheless, inform the transport company that all types of impact and vibrations should be avoided during transport.

 **Warning**
Risk of injury during transport

Any foot screws must be mounted if they are provided as a transport safeguard to prevent rolling and tipping. Additional measures must be taken to ensure that impermissible rolling and tipping are prevented.

Only use the provided lifting eyes / ring screws to lift the meter. Please observe the relevant permissible loads for the lifting equipment. Prior to lifting, ensure that the load is securely fastened. Do not stand under suspended loads.

The device can slip, topple over or fall down when being lifted and set down. The device can fall over if the bearing capacity of the lifting equipment is disregarded. There is a risk of severe injury for nearby persons.

If the device is delivered on a Euro pallet, the device can be transported on the pallet using a pallet truck or forklift.

The gas meters and accessories must be protected from jarring and vibrations during transport.

The gas meters or any inlet/outlet pieces have a flange as an end piece. The flanges are sealed with a protective sticker or fitted with a plastic dummy plug. The protective stickers and/or dummy plugs must be removed without leaving any residue prior to installation in the pipeline. Residue from this film changes the flow and causes measuring errors!

This protection must be re-applied to the flanges for transport or storage of the device.

1.2.8 Scope of delivery

The scope of delivery can differ depending on the optional orders. The following is "normally" included in the scope of delivery:

Part	Quantity
TME400-VC (or TME400-VCF) turbine meter with integrated electronic volume corrector	1
1 Lubricating oil bottle	Optional
Lubricating instructions	1
Manual	1

Test log	1
Calibration certificate	1
Material test certificate	1
Strength test certificate 3.1.	Op-tional

15

1.2.9 Storage

Avoid extended periods of storage. After storage, inspect the device for damage and test for correct function. Contact the RMG service department to arrange for inspection of the device after a storage period of longer than one year. For this purpose, return the device to RMG.

Note
<p>Storage must take place in a dry and protected room.</p> <p>It must be ensured that all open pipes are sealed.</p>

1.2.10 Disposal

Dispose of the **packaging and protective material** (e.g. drying mats) as well as the **parts and devices** supplied in an environmentally friendly manner in accordance with the country-specific laws, standards and guidelines.

When disposing of the device, observe the overview of the materials used on page 95.

Before disposing of the device, remove the **batteries**, mask their contacts and dispose of the batteries separately.

Residual amounts of **lubricating oil** in the bottles supplied must also be disposed of separately.

Make sure that your disposal company is authorized to dispose of the relevant parts and materials.

1.3 Overview of versions

1.3.1 Description

The **TME400-VC** is a turbine meter which is used for volume measurement of the operating volume of non-aggressive gases and burnable gas. The operating volume flow is determined based on the turbine speed, which is scanned by means of a Wiegand or Reed sensor element and then added together. An optional 2-channel measuring head version can be implemented for inspection purposes, particularly for use in custody-transfer applications. The result is registered in an electronic meter. This operating volume flow is determined for the present pressure and temperature conditions, with are also detected. The integrated volume corrector of the TME400-VC enables calculation of the standard volume flow from the operating volume flow with the pressure and temperature data (**V**olume **C**orrector). Special gas properties can be factored in using different gas models for correct gas status determination. The measured operating volume and / or the calculated standard volume are added up in internal archives.

There are a high-frequency (HF) and a low-frequency (LF) output, where the HF output is preferably used as a flow sensor for control tasks and remote transmission. In addition to these outputs, the TME400 VC has a serial RS-485 interface for digital data readings and parameterization. The TME400-VC is used in **non-custody-transfer** applications.

The **TME400-VCF** (MID) is the version of the TME400-VC for **custody-transfer** applications. The device can be activated via the same outputs.

The **TME400-VCF** (MID) is the turbine meter with volume corrector for custody-transfer applications and has an equivalent function and operating method to the TME400-VC. It is used in **custody-transfer applications**.

1.3.2 Device features

TME400-VC

- Non-custody-transfer measurements
- Electronic meter
- Flow rate display
- Measurement and display of pressure
- Measurement and display of temperature
- Peak value display for the flow value
- Determination and display of the standard volume flow
- Alarm output

- Optionally available in a version with remote meter (distance from meter head to meter: 10 m; see *appendix C Dimensions*)
- 2x pulse inputs selectable for Reed, Wiegand and external pulse transmitters (remote meters)
- 1x contact input
- 1x HF output (input pulse of pulse input 1 is output with defined pulse width of 1 ms)
- 1x LF output with defined pulse width (20 ms, 125 ms or 250 ms)
- 1x input for digital pressure sensors (see below)
- 1x temperature input Pt1000 (see below)
- 1x RS-485 with external power supply
- 1x optional power module
- Power supply via 3.6V lithium cell or an external power supply which is assigned to the RS-485 interface (supply via power module alone is not adequate and a battery is required for support)
- Archive memory for events, parameters, measurements

TME400-VCF

- In addition to the features of the TME400-VC, this version can be used for custody-transfer applications.

1.3.3 Firmware

The currently delivered devices have either firmware version 1.12 or 11.12 installed, depending on the components used in the index head. With the devices of the type TME 400-VC(F) there is no functional difference between the two versions. The installed version is shown in coordinate G02.

1.3.4 Power supply

Battery-operated device

The TME400 is equipped with a replaceable 3.6 V lithium battery. The device is designed for continuous operation for approximately 10 years. To achieve this, the devices may be operated for a maximum of 15 minutes per day with input pulses of 1 Hz.

Since the battery in the device is supplied with an insulating strip (positive pole protection), this strip must be removed before commissioning!

Battery-operated device with additional external power supply

An electric supply of the TME400 via the 4-20mA current loop reduces the power consumption from the batterie and typically extends the service life of the battery to more than 12 years.

If the TME400 is additionally electrical powered by the RS-485 interface, the service life of the battery is typically extended to clearly more than 12 years.

18

Battery replacement indicator

The remaining battery life is determined by means of an internal calculation. An indicator in the display appears when it is time to replace the battery. Battery replacement is described in *chapter 3.1.4 Battery replacement*. In parameter G20 *Date of last battery change* the date of the last battery change is displayed (see *chapter 4.3.3 Coordinates in context*).

Note

In case of a loss of the external power supply, the TME400 is supplied by the buffer battery. The battery symbol is blinking in this case.

1.3.5 Area of application

The TME400 is approved for use in hazardous areas with the following mark:



II 2G Ex ia IIC T4 Gb

The EC type approval certificate is:

**TÜV 17 ATEX 207566 X
IECEX TUN 18.0009 X**

The corresponding conformity certificates are provided in the annex. The RMG contact information is provided on the second and last page.

1.3.5.1 Installation and mounting position

The TME400-VC and TME400-VCF can be supplied with DIN and ANSI connections. Up to nominal diameter DN 200, the installation position of the turbine meter with permanent lubrication can be selected as required. From nominal diameter DN 250, the meter must be installed in the ordered installation position. It must also be ensured that the filling opening of the lubrication faces upwards.

1.3.5.2 Temperature ranges

The following temperature ranges are approved for the TME400 volume corrector and the turbine meter in standard version.

Temperature ranges	
Medium temperature	-25°C to +55°C
According to ATEX (T _{amb})	-25°C to +55°C (II 2G Ex ia IIC T4)
According to PED 2014/68/EU	-20°C to +80°C (spheroidal graphite iron) -40°C to +80°C (cast steel) -40°C to +80°C (stainless steel) -10°C to +80°C (welded version and round steel material)
Pressure safety for DN25 according to sound engineering practice, see PED 2014/68/EU, sec. 4, subsec. 3	-40°C to +60°C (aluminum)

Lower temperature limits are available on request with the welded version and round steel material.

Note

If different temperature ranges apply simultaneously, the smallest specified range applies for the overall system. This is also marked on the type plate.

⚠ Caution

Direct solar radiation must be avoided.

⚠ Danger

The temperature sensor must not be connected via the housing plug on the meter in hazardous areas; a dedicated cable must be routed for the temperature sensor!

1.3.6 Use of gas meters for different gases

Gas	Symbol	Tightness at 0°C and 1.013 bar	Meter housing	Comments
Natural gas		0.8	Standard	
City gas			Standard	
Methane	CH ₄	0.72	Standard	
Ethane	C ₂ H ₆	1.36	Standard	
Propane	C ₃ H ₈	2.02	Standard	
Butane	C ₄ H ₁₀	2.70	Standard	
Air		1.29	Standard	
Argon	Ar	1.78	Standard	
Helium	He	0.18	Standard	
Carbon dioxide (dry)	CO ₂	1.98	Standard	
Nitrogen	N ₂	1.25	Standard	
Hydrogen	H ₂	0.09	Standard	up to 20% Generally, a reduced measuring range
Ethylene (gaseous)	C ₂ H ₄	1.26	Special	Special version (also for humid gases): Teflon coating, special lubrication, special material, etc.
Biogas			Special	
Sour gas			Special	
Digester gas / sewage gas			Special	
Sulfur dioxide	SO ₂	2.93	Special	

The components of the gases must be within the concentration limits according to EN 437:2009 for test gases. Safe operation is guaranteed with these specified gases.

Other gases on request.

1.3.6.1 Suitability and safety for natural gas containing H₂

The TME400 can be used in hydrogen-containing natural gas. There are no safety-related concerns for this use.

Notice

In accordance with the German TR-G19 – the TME400 is suitable and approved for use in custody transfer applications – in natural gases with a maximum hydrogen content of 10 mol-%, with the accuracy specified in *chapter 1.4.2.9 Measuring accuracy*.

21

Since there are currently no certified test rigs in Germany to calibrate meters with higher hydrogen-containing gases, an accuracy above 10 mol-% cannot be tested or certified.

Not custody transfer measurements are of course possible in natural gases with a hydrogen content above 10 mol%. However, a reduced measuring range must be taken into account if applicable. Please contact RMG for further information.

1.4 Areas of application

The following chapter provides handling instructions for the TME400 turbine meter for the purpose of safe and reliable operation of the device.

Note

Some of the settings described below must not be made until you have read the explanations in chapter 4 Operation.

1.4.1 Working principle of the TME400

The working principle of a mechanical turbine meter is based on the measurement of the gas velocity of the flowing gas which powers a turbine wheel. The speed of the turbine within the measuring range (Q_{\min} - Q_{\max}) is approximately proportional to the mean gas velocity and thus the flow rate. The number of rotations, therefore, is a measurement for the gas volume flowing through.

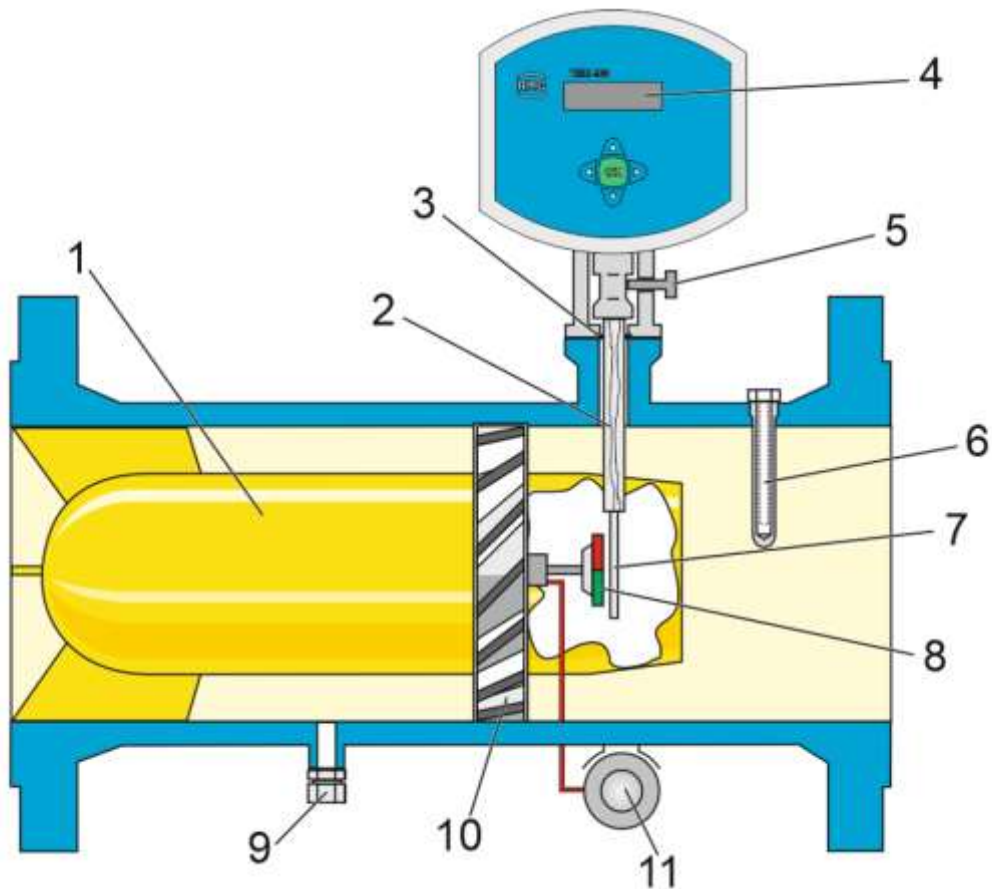

- | | | | |
|---|--|----|---------------------|
| 1 | Flow straightener | 7 | Sensor |
| 2 | Sensor sleeve | 8 | Permanent magnet |
| 3 | O-ring | 9 | Pressure connection |
| 4 | Counter | 10 | Turbine wheel |
| 5 | Clamp screw | 11 | Oil pump |
| 6 | Thermowell for temperature comparison (fiscal) | | |

Figure 1: Turbine meter sectional drawing

There is a permanent magnet on the end disc of the turbine shaft which induces a voltage pulse in the Wiegand sensor with every rotation. This pulse is supplied to the counter of the meter head, which detects the operating volume flow directly as a main totalizer and determines the gas volume flowing through the meter by adding up the pulses and division by the meter factor (number of pulses per m³). This operating volume is shown in the display of the TME400.

Note

The unchanged signal frequency of the sensor element is output at the HF output.

The LF output transmits this HF frequency with a variable scaling factor (*chapter 4.3.3.1 Volume / Meters*).

1.4.2 Integrating the turbine meter into the pipeline

Turbine meters from RMG are equipped with connecting flanges. For a secure connection, the connection dimensions of the flanges of the pipelines to be connected must match the connection dimensions of the flanges of the device.

- ANSI pressure levels: flange connection dimensions correspond to the standard ASME B 16.5.
- DIN pressure levels: flange connection dimensions correspond to the standard DIN EN 1092.

1.4.2.1 Seals

- Flat seals: $k_0 \times K_D = 20 \times b_D \mid k_1 = 1.3 \times b_D$ [N/mm]
- Grooved seals: $k_0 \times K_D = 15 \times b_D \mid k_1 = 1.1 \times b_D$ [N/mm]
- Spiral seals: $k_0 \times K_D = 50 \times b_D \mid k_1 = 1.4 \times b_D$ [N/mm]
- Octagonal ring-joint seal: $K_D = 480$ N/mm²

Refer to the tables below for the recommended dimensions.

Flat seals (DIN 2690 / EN 12560-1 Form IBC)

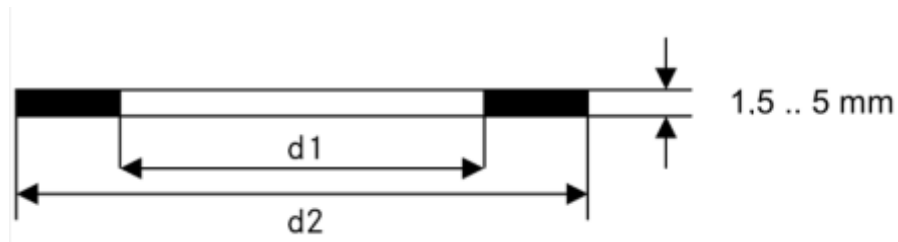

DN		d1	PN 10	PN 16	ANSI 150	PN 25	PN 40
50	2"	77	107	107	105	107	107
80	3"	90	142	142	137	142	142
100	4"	115	162	162	175	168	168
150	6"	169	218	218	222	225	225
200	8"	220	273	273	279	285	292
250	10"	274	328	330	340	342	353
300	12"	325	378	385	410	402	418
400	16"	420	490	497	514	515	547
500	20"	520	595	618	607	625	628
600	24"	620	695	735	718	730	745

Grooved (EN 12560-6 with centering ring)

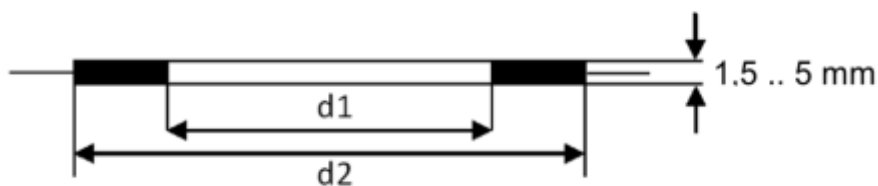

		ANSI 300 / ANSI 600		PN 64	
DN		d1	d2	d1	d2
50	2"	69.8	88.9	65	87
80	3"	98.4	123.8	95	121
100	4"	123.8	154.0	118	144
150	6"	177.8	212.7	170	204
200	8"	228.6	266.7	220	258
250	10"	282.6	320.7	270	315
300	12"	339.7	377.8	320	365
400	16"	422.3	466.7	426	474
500	20"	530.2	581.0	530	578
600	24"	631.8	682.6	630	680

Spiral seals (EN 12560-2 with centering ring)

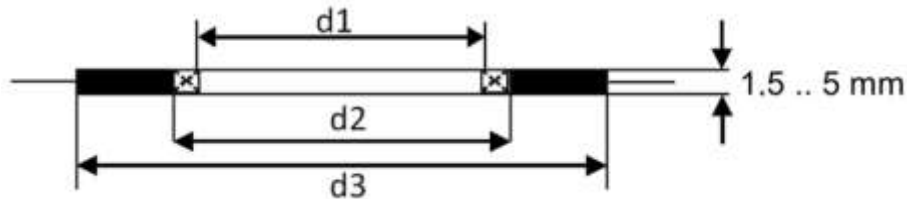

		ANSI 300			PN 64			ANSI 600		
DN		d1	d2	d3	d1	d2	d3	d1	d2	
50	2"	51	69.9	85.9	54	66	84	51	69.9	85.9
80	3"	81	101.6	120.7	86	95	119	81	101.6	120.7
100	4"	106,4	127.0	149.4	108	120	144	106,4	120.7	149.4
150	6"	157,2	182.6	209.6	162	174	200	157,2	174.8	209.6
200	8"	215,9	233.4	263.7	213	225	257	215,9	225.6	263.7
250	10"	268,3	287.3	317.5	267	279	315	268,3	274.6	317.5
300	12"	317,5	339.9	374.7	318	330	366	317,5	327.2	374.7
400	16"	400	422.4	463.6	414	426	466	400	412.8	463.6
500	20"	500	525.5	577.9	518	530	574	500	520.7	577.9
600	24"	603,3	628.7	685.8	618	630	674	603.3	628.7	685.8

For flanges according to ASME to be observed:

- Gasket type: flat gasket tanged sheet metal/graphite or similar
- Gasket dimensions: according to ASME B16.21
- Seal data: design seat tension
 $Y_{\max} = 45 \text{ MPa}$, sealing factor $m_{\max} = 2.5$

Note

When flange seals which protrude into the pipeline are used for turbine meters, the measuring accuracy can be influenced negatively. Ensure that the flange seals do not protrude beyond the seal surfaces into the pipeline.

Danger

Gas escape due to incorrect seal

If incorrect flange seals are used for the assembly of turbines, an explosive gas mixture can form due to leaks.

Danger of poisoning and explosion!

In addition, the stress on the flange is increased to an impermissible level when tightening the thread bolts.

Ensure secure fastening/attachment of the TME400 during assembly in order to avoid crushing. Ensure that you keep your fingers (or other body parts) away from these openings and gaps when pulling the flanges together.

1.4.2.2 Screws

		Temperature ranges for screws and nuts		
		-10°C to +80°C	-40°C to +80°C	
Pressure levels		Option 1	Option 2	Option 3
up to and including 40 bar	Screws according to DIN EN ISO 4014 in material 5.6 Nuts according to DIN EN ISO 4032 in material 5-2	Screws according to DIN EN ISO 4014 in material 25CrMo4, Nuts according to DIN EN ISO 4032 in material 25CrMo4		
40 bar or higher	Threaded bolts according to ANSI B1.1 material ASTM A 193 degree B7, Nuts according to ANSI B1.1 material ASTM A 194 degree 2H,	Threaded bolts according to ANSI B1.1 material ASTM A 320 degree L7, Nuts according to ANSI B1.1 material ASTM A 320 degree L7	Threaded bolts according to ANSI B1.1 material 42CrMo4 Nuts according to ANSI B1.1 material 42CrMo4	Reduced shaft screws according to DIN 2510 material 25CrMo4, Nuts according to DIN 2510 material 25CrMo4

28

For flanges according to ASME to be observed > -10°C:

Screw material SA.193 B7/B7M according to ASTM A193 Grade B7 or comparable materials.

Note
Reduced shaft screws must only be used for devices in the area of application of the Pressure Equipment Directive.

The durability of the flange connection was verified using the screws listed in this chapter in combination with the seals listed in the previous chapter with the following maximum material characteristic data according to AD200 rules and regulations. Other screw/flange variants were not tested.

Malfunctions can occur with incorrect seals.

1.4.2.3 Meter housing material

Cast steel or round steel material, depending on the pressure level and nominal diameter. Aluminum or stainless steel for the screw-type versions.

1.4.2.4 Installation

Note

Installations disturbing the gas flow directly upstream of the turbine meter must be avoided (see DVGW guideline G 492 II and PTGB guideline G 13).

An inlet pipe of at least 2 x DN is required upstream from the turbine meter TME400. The inlet pipe must be designed as a straight pipe section with the same nominal diameter as the meter. With heavy upstream perturbations, installation of straighteners is recommended (refer to the table on the next page). A pipe or bend with the nominal diameter of the meter having a total length of 2 x DN must be arranged downstream from the meter.

Temperature measuring devices must be installed at a distance of at least 1 x DN or at least 300 mm with nominal diameters \geq DN 300.

If there is perturbation (e.g. a gas pressure control device) upstream from the inlet pipe, a perforated plate straightener is also necessary. Perforated plate straighteners according to ISO 5167-1 or the type RMG LP-35, which cause a pressure loss by a factor of 2.5 in comparison with the standard straightener, can be used.

Recommended installation with straightener

Perforated plate straightener LP 35

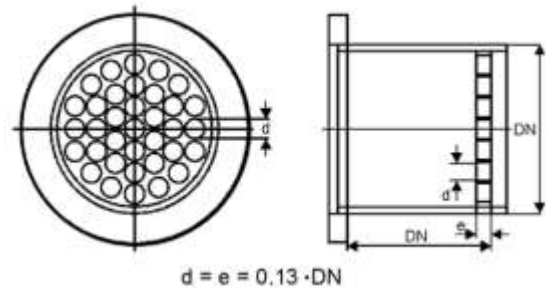
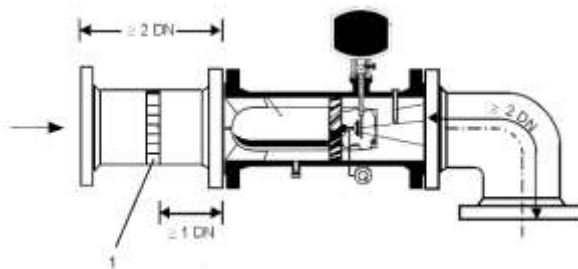

1 Perforated plate straightener

- The opening angle of the reducing or expansion pieces which are installed upstream from the TME400 turbine meter must not be more than 30°.

Note

If necessary, a screen must be installed before the inlet pipe of the meter for protection of the turbine meter from foreign objects which may be present in the gas flow. The screen can be, for example, a perforated plate/filter of \varnothing 0.15 mm.

⚠ Danger

Protect the turbine meter from damage caused by high pressure fluctuations in the flow, e.g. if the downstream pipeline system is filled or blown off.

30

⚠ Danger

Welding on the line must only take place at a safe distance from the meter. Extreme temperatures in the line near the meter can cause permanent damage to the meter.

⚠ Danger

Establish all electrical connections between meters and amplifiers or flow computers as specified in the installation manual. Ensure that the connections are intrinsically safe.

⚠ Caution

Liquids remaining in the line after hydrostatic testing can damage internal parts of the meter.

If hydrostatic testing is not possible, the turbine meter must be replaced with a pipe section. Ensure that there is no liquid remaining in the line above the meter after the hydrostatic testing.

1.4.2.5 Threshold values

The following threshold values are recommended for maximum durability and the highest measuring accuracy:

Note	
Maximum overload	< 20% above Q _{max} , short-term (< 30 sec)
Maximum flow rate changes and/or impact loads	< 0.01·Q _{max} /sec ≙ 1% of Q _{max} /sec e.g. start-up 0 - 100%: > 100 sec
Maximum pressure change:	< 0.1 bar/sec
Maximum flow pulsation:	< 5%
Particle size in the gas flow:	< 5 µm
Lubrication:	Refer to lubrication chapter Intervals depend on the status of the gas (condensate, rust, dust)
Vibration / mech. vibration:	< 1 mm/sec (vibration speed)

These measures must be determined and checked during commissioning, before filling, during the start-up and run-in phase of the meter and evaluated, in particularly with simultaneous occurrence of multiple of these threshold values. Intervention in the system for improvement of measuring conditions must be carried out when the aforementioned threshold values are reached.

Note
<p>The operator should record the overall measurement data (meter and operating data) during the entire operation in order to be able to recognize causes of potential damage at an early stage and to intervene in good time.</p> <p>Remedy and/or relief of critical operating statuses can be achieved, for example, with the following measures:</p> <ul style="list-style-type: none"> • Start-up screen (MW < 0.15 mm) • Filter • Meter protection perforated plates (Ø 3 - 4 mm) • Valves with control drive (flow change) • Check valves (pulsation, backflow)

1.4.2.6 Technical guideline G13

The installation conditions for new systems according to TRG G13 and the facilitated installation conditions for RMG turbine meters are compared in the table below.

Type of upstream perturbation	Installation conditions according to TR G13	Installation conditions for RMG type TME400 meters	Comments
none	Inlet \geq 5 DN Outlet \geq 2 DN	Inlet \geq 2 DN Outlet \geq 2 DN	The outlet pipe can also be designed as a bend.
	Inlet \geq 10 DN		Perturbation upstream from this inlet pipe does not have to be factored in when the requirements for an alternating and pulsing flow are fulfilled.
Bend	Inlet \geq 5 DN	Inlet \geq 2 DN	
Bends in 2 planes	Inlet \geq 5 DN plus 2 perforated plate straighteners or a bend straightener	Inlet \geq 2 DN	
Gas pressure regulating device with an attenuator	Inlet \geq 5 DN	Inlet \geq 2 DN plus 1 perforated plate straightener	
Gas pressure regulating device without an attenuator	Inlet \geq 5 DN plus 2 perforated plate straighteners	Inlet \geq 2 DN plus 1 perforated plate straightener	
Diffuser	Inlet \geq 5 DN plus 1 perforated plate straighteners	Inlet \geq 2 DN	
Diffuser with swirling flow	Inlet \geq 5 DN plus 2 perforated plate straighteners	Inlet \geq 2 DN	

Perforated plate straightener

The following options are available for the straighteners:

Perforated plate straightener RMG L1 - L3 according to ISO 5167-1 and DIN 1952

Perforate plate straightener RMG LP-35

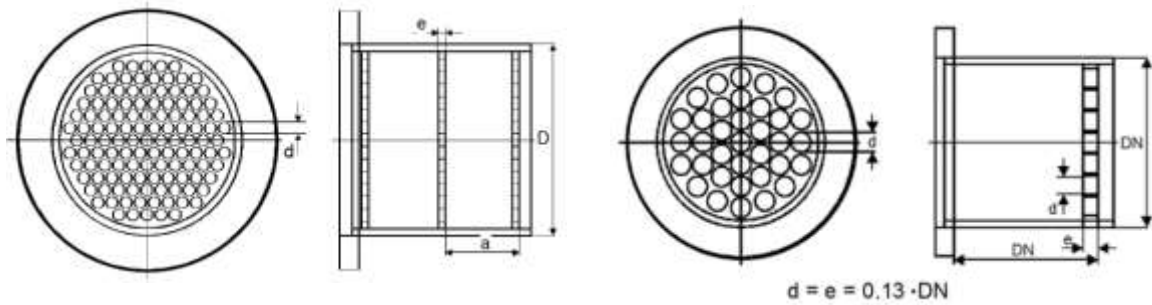

Characteristics	ISO/DIN	L1-L3	RMG LP-35
Hole diameter d	$d \leq 0.05 D$	0.04 D	0.13 D
Plate thickness e	$e \geq d$	$e = d$	0.13 D
Plate clearance a	$0.5 D \leq a \leq 1 D$	0.5 D	-
Opening ratio m	$0.2 \leq m \leq 0.4$	0.3	0.6
Dynamic pressure loss Δp		5 - 15 ($c^2 \rho / 2$)	2 - 15 ($c^2 \rho / 2$)

With the RMG turbine meters, these straighteners fulfill the requirements of technical guideline G 13 and are approved with approval number D 81 / 7.211.10 for turbine meters.

1.4.2.7 Standards / guidelines

All RMG turbine meters have passed upstream perturbation measurements according to OIML recommendation IR-32/89, Annex A, with slight and heavy upstream perturbation. Therefore, this meter design fulfills the installation conditions according to technical guideline G 13, section 1. The PTB testing vol. 29 and 30, Testing of volume gas meters with air at atmospheric pressure and high-pressure testing rules apply as a testing requirement. The RMG turbine meter TME400 conforms to EN12261. The measuring accuracy in the range of $0.2 Q_{max}$ to Q_{max} is between $\pm 1.0 \%$ to 1.5% (see *chapter 1.4.2.9 Measuring accuracy*). The TME400 has an electronic suppression by external shut down of the totalizer of the slow down cutoff of the turbine wheel after the flow is stopped.

1.4.2.8 Measuring ranges

Type TME400 turbine meters have measuring ranges of at least 1:20 at atmospheric pressure (see *chapter 1.4.2.9 Measuring accuracy*). At a higher pressure, the measuring range can be expanded to 1:50. The measuring ranges are between 2.5 and 25,000 m³/h (operating conditions), depending on meter size.

The turbine meters with nominal diameter of DN25 and DN40 can be used up to a maximum of 16 bar. However, there may be restrictions for threaded connections that are subsequently used.

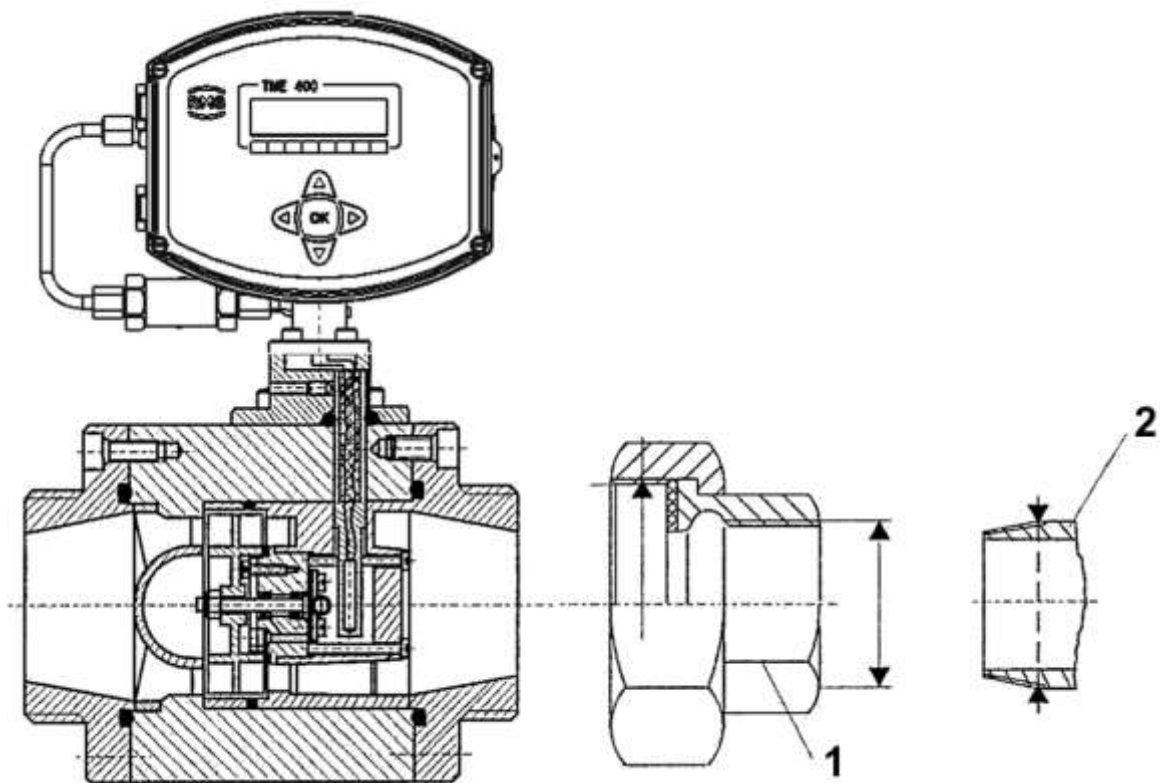

Figure 2: Threaded connection for DN25 and DN40

1 – Pipe fitting DIN2950

DN25 thread G 1 ½ ISO 228-1

DN40 thread G 2 ¼ ISO 228-1

DN25 / thread Rp 1 ISO 7-1

DN40 / thread Pp 1 ½ ISO 7-1

2 – Gas pipe

DN25 / thread R1 ISO 7-1

DN40 / thread R1 ½ ISO 7-1

According to DIN30690-1, the maximum operating pressure for non-flammable gases may not exceed 16 bar; for flammable gases, EN746-2 defines a maximum pressure of 5 bar for DN25 and 2 bar for DN40. Usually these pressure restrictions are specified on a plate on the pipe fittings.

1.4.2.9 Measuring accuracy

The following error limits apply within the permissible measuring range:

DN	Qmin [m³/h]	Qmax [m³/h]	MR	Measurement deviation in the range of	
				Qmin-0.2 x Qmax [%]	0.2 x Qmax-Qmax [%]
25	2.5	25	1:10	3	2
40	6	70	1:12	3	1.5
80	13	160	1:12	3	1.0
50	6	100	1:16	3	1.5
80	16	250	1:16	3	1.0
	25	400	1:16	3	1.0
100	25	400	1:16	2	1.0
	40	650	1:16	2	1.0
80	13	250	1:20	3	1.5
	20	400	1:20	3	1.5
100	20	400	1:20	3	1.5
	32	650	1:20	3	1.5

Note

With a slightly smaller measuring range of 1:16, turbine meters are also available in nominal diameters 80 and 100, which have an increased accuracy with a deviation of max. $\pm 1\%$ in the range of $0.2 \times Q_{\max} - Q_{\max}$.

150	32	650	1:20	2	1
	50	1000	1:20	2	1
	80	1600	1:20	2	1
200	80	1600	1:20	2	1
	125	2500	1:20	2	1
250	125	2500	1:20	2	1
	200	4000	1:20	2	1

300	200	4000	1:20	2	1
	325	6500	1:20	2	1
400	325	6500	1:20	2	1
	500	10000	1:20	2	1
500	500	10000	1:20	2	1
	800	16000	1:20	2	1
600	800	16000	1:20	2	1
	1250	25000	1:20	2	1

1.4.2.10 Pressure loss

The measuring points for determining pressure loss are 1 x DN upstream and downstream of the meter. The pressure loss is calculated according to the following formula:

$$\Delta p = Z_p \cdot \rho \cdot \frac{Q_m^2}{DN^4}$$

where:	Δp	pressure loss	[mbar]
	Z_p	coefficient of pressure loss	[-]
	ρ	operating density	[kg/m ³]
	Q_m	volume flow at measurement conditions	[m ³ /h]
	DN	nominal meter diameter	[mm]

Device type	Z_p
Turbine meter TME400	5040
Perforated plate straightener L1 according to ISO/DIN	3150
Perforated plate straightener L2 according to ISO/DIN	6300
Perforated plate straightener L3 according to ISO/DIN	9450
Perforated plate straightener LP-35 RMG standard	1260
Bend straightener RB 19 according to ISO/DIN	1260

The values for Z_p are rough averages. The exact value is calculated from the pressure loss, which is determined when testing the meter.

Example calculation for the pressure loss of a turbine meter:

TME400 in DN 150:

$Q_m = 650 \text{ m}^3/\text{h}$
 $\rho = 1.3 \text{ kg}/\text{m}^3$ (natural gas at 600 mbar overpressure)
 $Z_p(\text{TME400}) = 5040$ (see the table above)

Calculation:

$$\begin{aligned} \Rightarrow \Delta p &= 5040 \cdot 1,3 \cdot \frac{650^2}{150^4} \text{ mbar} \\ &= \underline{\underline{5.5 \text{ mbar}}} \end{aligned}$$

1.4.2.11 Putting the device into operation

Note

You receive the TME400 parameterized and calibrated according to your specifications, so that no additionally settings are generally required.

However, check whether these settings match your specifications; check the settings of the pulse width, the frequency reducer and the settings of the current output (for versions with current output).

Set up all totalizers to the meter status which you desire. (see *chapter 4.2 Programming*).

Note

Parameters can be changed exclusively with the device open.

1.4.2.12 Maintenance / lubrication

The TME 400 turbine gas meter is maintenance-free (apart from the lubrication for meters with an oil pump).

Meters in custody transfer operation must be calibrated at the prescribed intervals (according to national law). For meters in secondary operation, we recommend from a metrological point of view a check at the manufacturer every 5 to 8 years.

The TME400 is equipped with permanently lubricated bearings up to a nominal diameter of DN150 as standard. Nominal diameter of DN200 or higher are provided with

an integrated lubricating device. Optionally, the TME400 can also be equipped with the "small oil pump" lubricating devices for DN25 to DN150 versions.

The type of lubricating device and the lubricant requirement depend on the nominal diameter and the pressure level:

Nominal diameter	Pressure classes	Lubricating device	Lubricant requirement
DN25-DN150	All pressure classes	As necessary (see below) optional small oil pump (push-button operated)	Every 3 months 6 strokes
DN200	All pressure classes	Small oil pump (push-button operated)	Every 3 months 6 strokes
DN250	PN10 to PN16 ANSI 150		
DN250	PN25 to PN100 ANSI300 toANSI600	Large oil pump (lever operated)	Every 3 months 2 strokes
> DN300	All pressure classes		

Also observe the notice plate on the housing.

In unfavorable conditions, e.g. with an accumulation of water and hydrocarbon condensate, as well as dust-laden gases, more frequent lubrication is recommended, even daily in extreme cases (e.g. with continuous condensate formation).

Note

Recommended lubricating oil:

Shell Tellus S2 MA 10 or another oil with 2 to 4°E at 25°C.

2 Installation

2.1 Electrical connections

Open the cover of the meter in order to reach the electrical connections.



Figure 3: Unscrewing the screws to open the cover

Remove – if necessary – the printed circuit board for sealing of the calibration button.

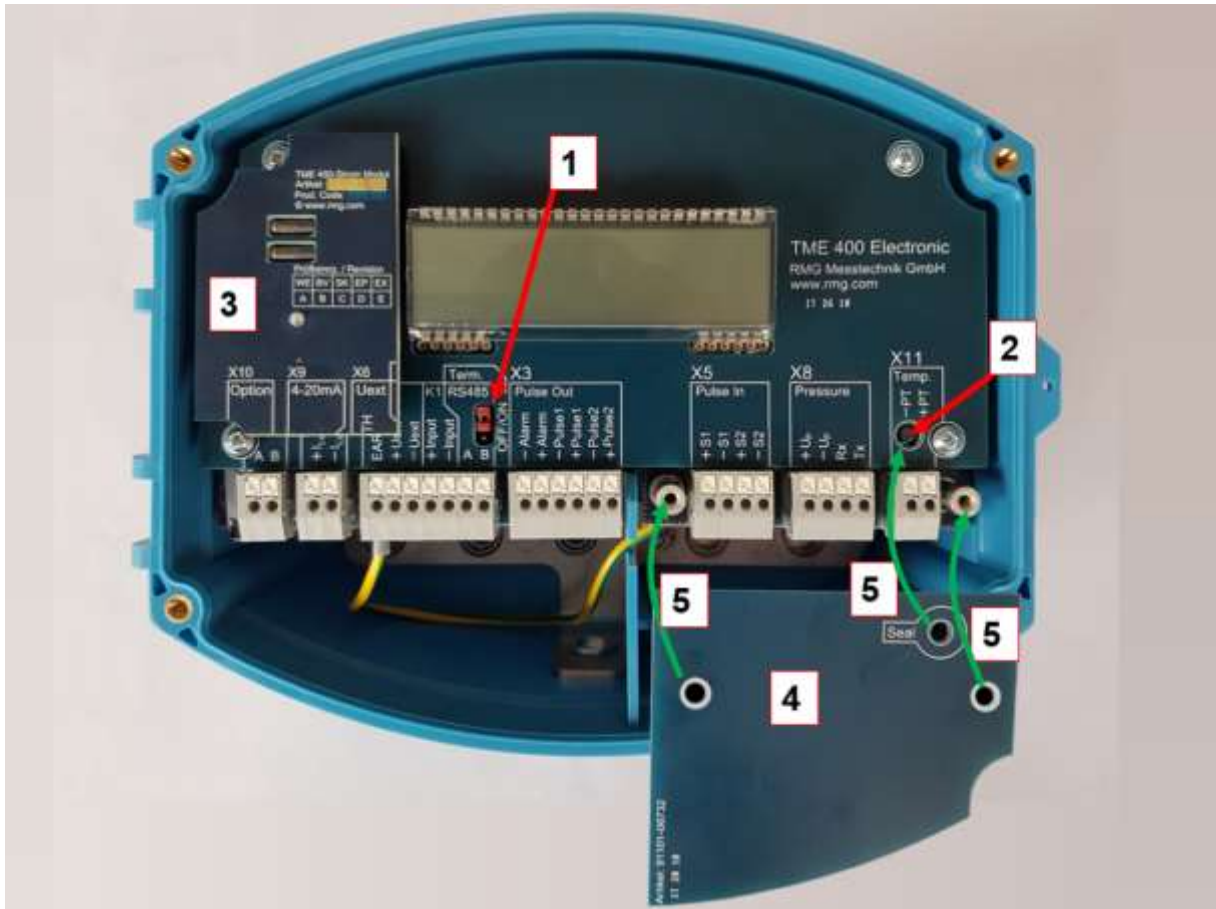

Figure 4: Unscrew the screws to remove the cover

- 1 Jumper for RS 485 terminating resistor. Bridged: with 120 Ω; open: ∞ Ω
- 2 Calibration switch
- 3 Current module board
- 4 Cover plate for pressure and temperature sensor and calibration switch
- 5 Normal position, indicated by green arrows

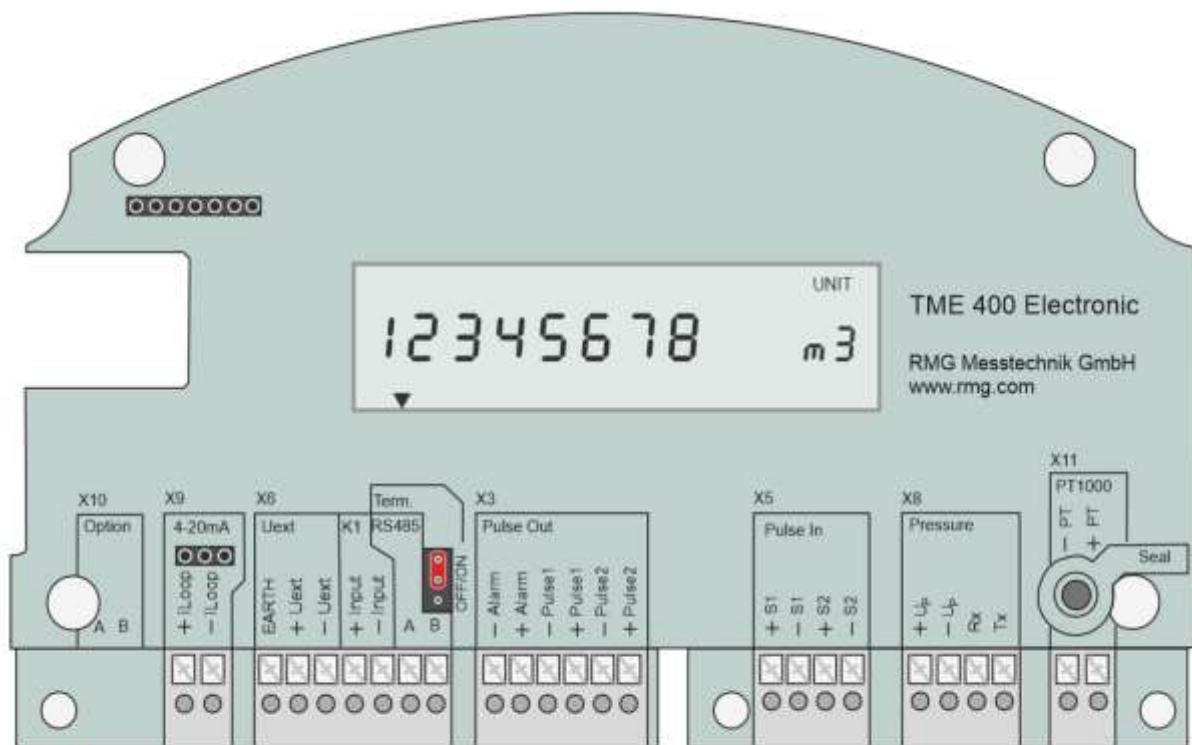

Figure 5: Connection assignment of the TME400

Refer to *Figure 5: Connection assignment of the TME400* for the assignment. The connection of internal sensors is carried out in accordance with the current standards, this applies in particular to the earthing of the pressure sensor.

If, for example, the TME400 is to be used as a "flow sensor", the current must be connected to 4..20 mA (**terminal block X9**). The 4..20 mA current is then connected to the two terminals. For this function, the optional current module must be plugged in at the top left (see *Figure 4 Unscrew the screws to remove the cover*).

The "sensor" TME400 is passive, it is fed and limits the current to the corresponding value. With this use, the current serves as an additional current supply (see *chapter 1.3.4 Power supply*). Here, care must be taken to ensure that this power supply is galvanically isolated.

If digital communication with the TME400 is required, it can be connected to the RS485. The differential signals are obtained via data lines A and B under RS485 (**terminal block X6**). Please pay attention to crossed signal lines and change the connections if appropriate. If necessary, the data interface can be conditioned using a jumper. Normally, the resistance is infinitely large ($\infty \Omega$); for a point-to-point

connection or if the terminal device is part of a bus system, the resistance must be set to 120 Ω .

Via "+ Uext" (external voltage supply, positive potential) and "- Uext" (external voltage supply, negative potential) the TME400 can be fed with 6-30 VDC in addition to the internal battery (in non-Ex areas). "Earth" is used for internal voltage balance. The power supply can be independent or in combination with the RS485 interface. Anyhow, this supply voltage is required for communication via the RS485 interface.

Terminal block X6 also contains a digital input K1, which can be used to start, stop and reset the totalizer; "+Input" is the contact input for positive potential, "-Input" the contact input for negative potential.

Caution

In the Ex version, refer to the EC type approval certificate for the maximum values for the current output and the RS-485!

Via "Pulse In" (**terminal block X5**), pulses proportional to the flow rate at measurement conditions can be read from an encoder with 1 or 2 frequency outputs (main encoder and second redundant encoder if required).

Encoder (sensor) 1 is connected to the terminals via "+S1" (positive potential) and "-S1" (negative potential), encoder (sensor) 2 is connected to "+S2" and "-S2". This is especially necessary for the TME400-VMF version operated at custody-transfer applications. The sensor types can be selected in coordinates Z26/27 (see chapter 4.3.3.7 Settings). Pulse input 2 is only active if a 2-channel counting mode is selected (coordinate Z25).

Via "Pulse Out2" (**terminal block X3**) pulses and redundant pulses can be output. An alarm output can also be connected here. These six terminals combine the three digital outputs:

-Alarm: Alarm output negative potential

+Alarm: Alarm output positive potential

The alarm output works according to the closed-circuit current principle. The switching contact is closed in undisturbed condition.

-Pulse 1: HF output negative potential

+Pulse 1: HF output positive potential

At this output, the arriving pulses at pulse input 1 are synchronously with a pulse width of 1 ms.

-Pulse 2: LF output negative potential

+Pulse 2: LF output positive potential

Output pulses are output at these terminals depending on the change in the volume flow rate. The pulse output factor can be used to weight the number of output pulses in relation to the increase in volume.

For the device types TME400-VC and TME400-VCF, the dependence of the pulse output on the standard volume can also be selected (see coordinates A11 and A21). In coordinate A23 the possible pulse width can be 20ms, 125ms or 250ms.

A pressure sensor can be connected to the four connections of **terminal block X8**: "+Up" positive and "-Up" negative voltage supply for pressure sensor; "RX" or "TX" are the serial data received from the pressure sensor or sent to the pressure sensor.

The temperature sensor, a Pt1000, is connected to the terminals **of terminal block X11** in two-wire connection. Pressure and temperature sensors are generally only in use with the TME400-VC and TME400-VCF versions.

The terminals of the **terminal block X10** are connections for an optional module which is not yet supported by the firmware.

Use the wire end ferrules for the connecting cable and route them in from below; a seal holds the cable. To be able to pull a cable out again, press the small white square (marked with the X) down using a small screwdriver (at the bottom in *Figure 4: Unscrew the screws to remove the cover* and *Figure 5: Connection assignment of the TME400*; top of the plug strip) in order to open the locking device. Hold down the square and pull the cable out of the connector strip.

Some connection examples are given on the following pages. Anyhow, please check for further connections the data and limitations of the connected devices in the documentations of these devices.

Caution

**The TME400 and connected devices do not have any plugs that have a to prevent polarity reversal.
Pay careful attention to the correct connections!**

Ex version
with modules Phoenix / Turck

44

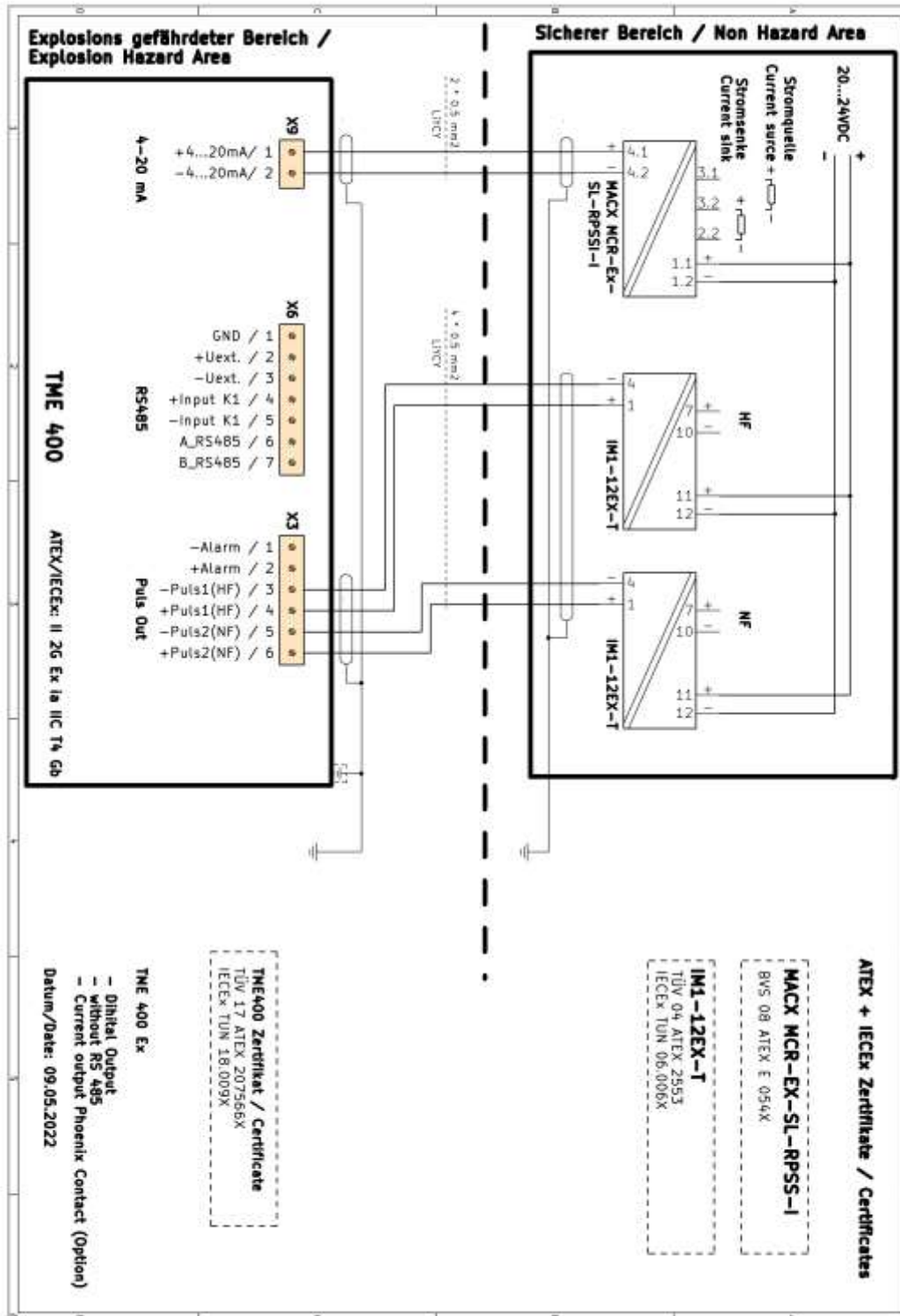

Ex version
with modules Pepperl+Fuchs / Turck

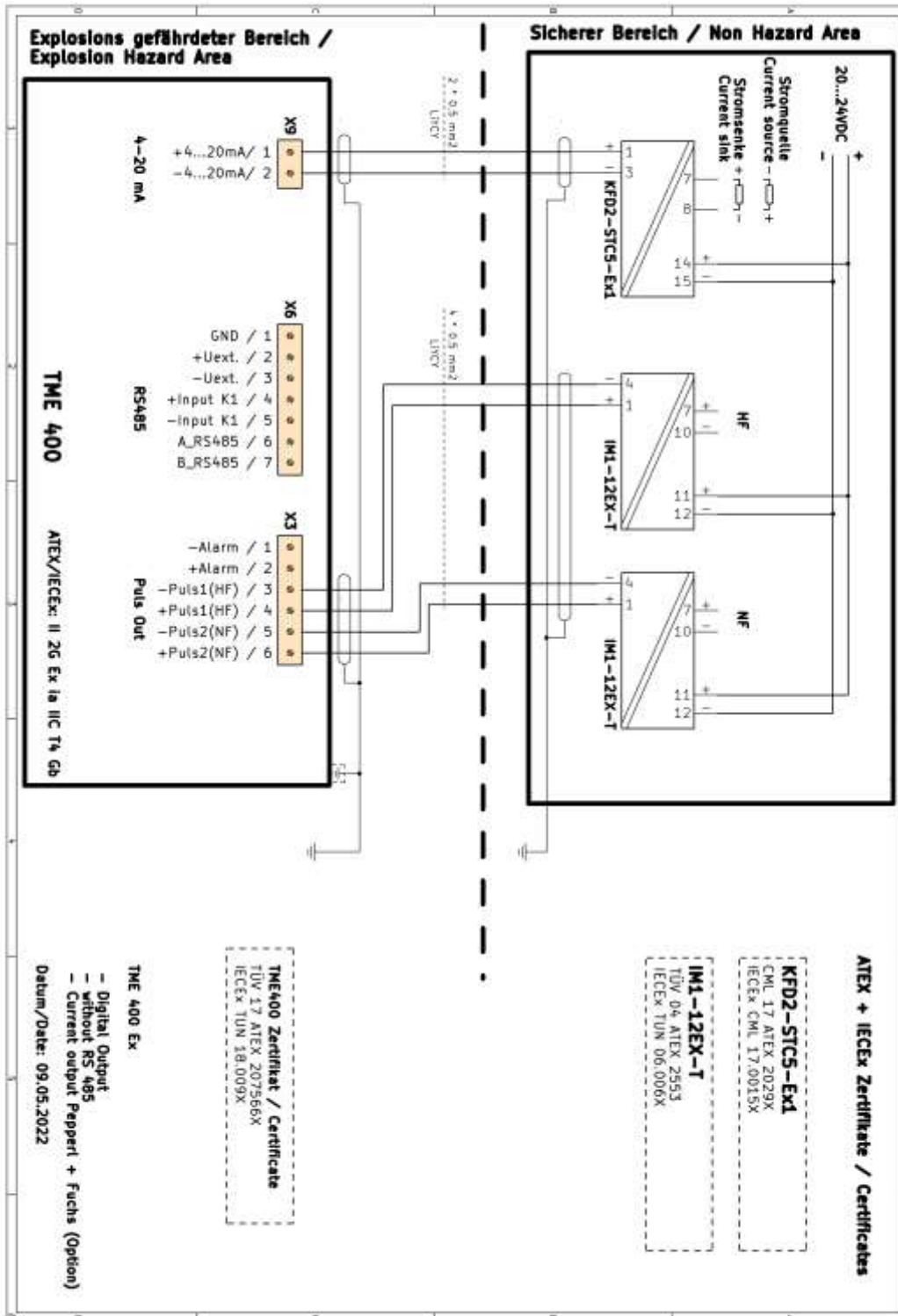

**Ex version
with modules Phoenix / Omron / Datcom**

46

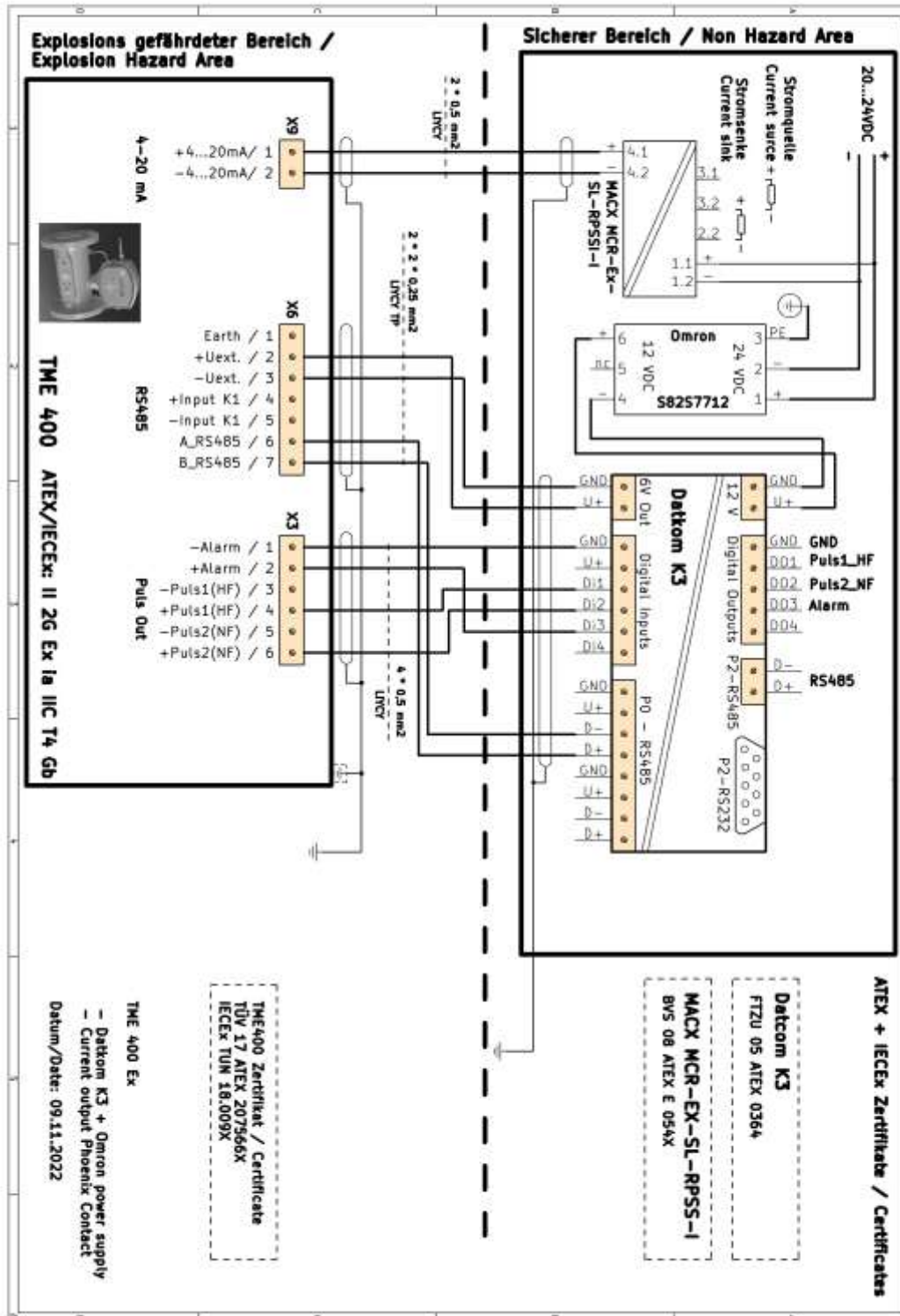

Ex version
with modules Pepperl+Fuchs / Omron / Datcom

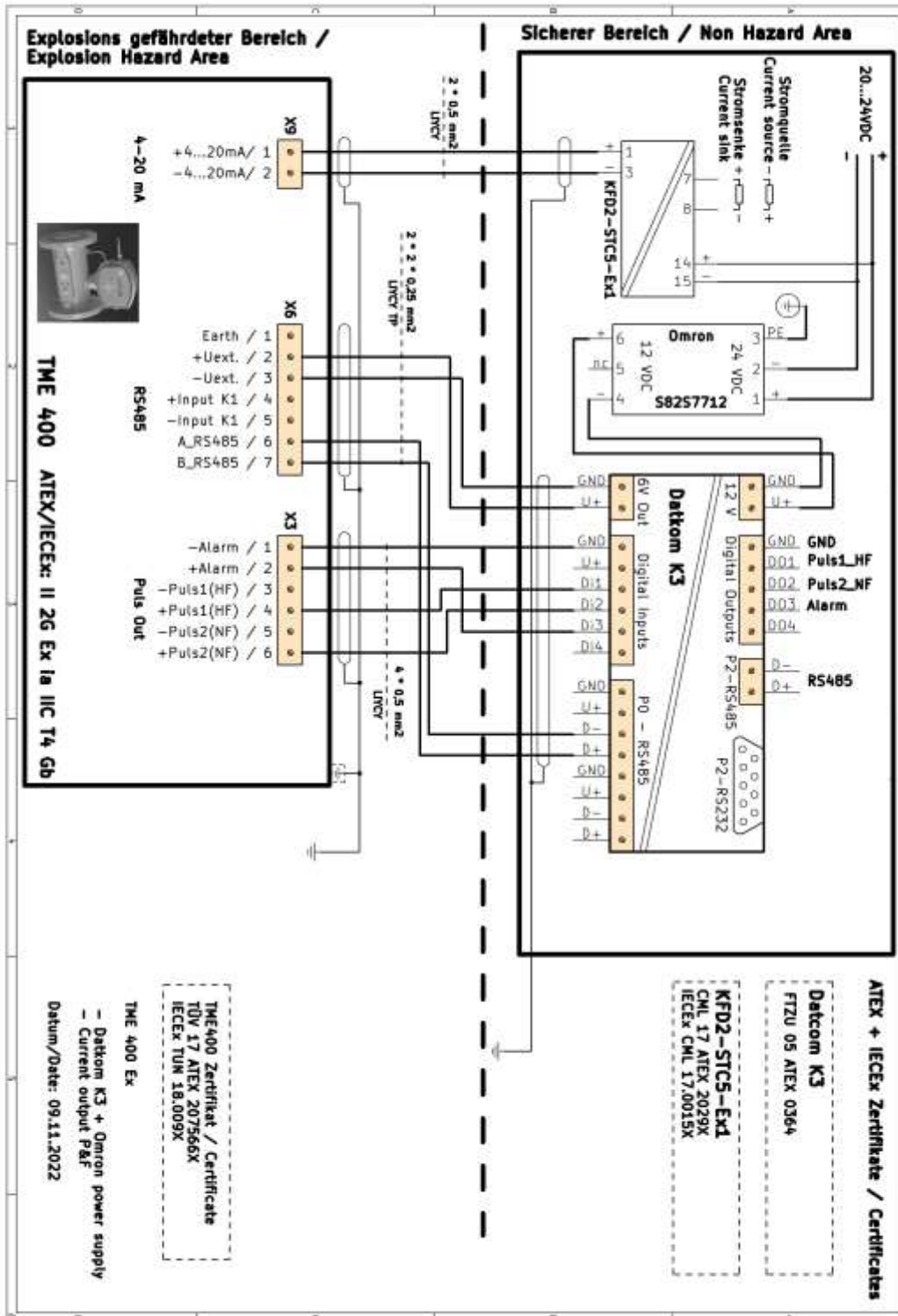

**Ex version
with modules Phoenix / Meanwell / Datcom**

48

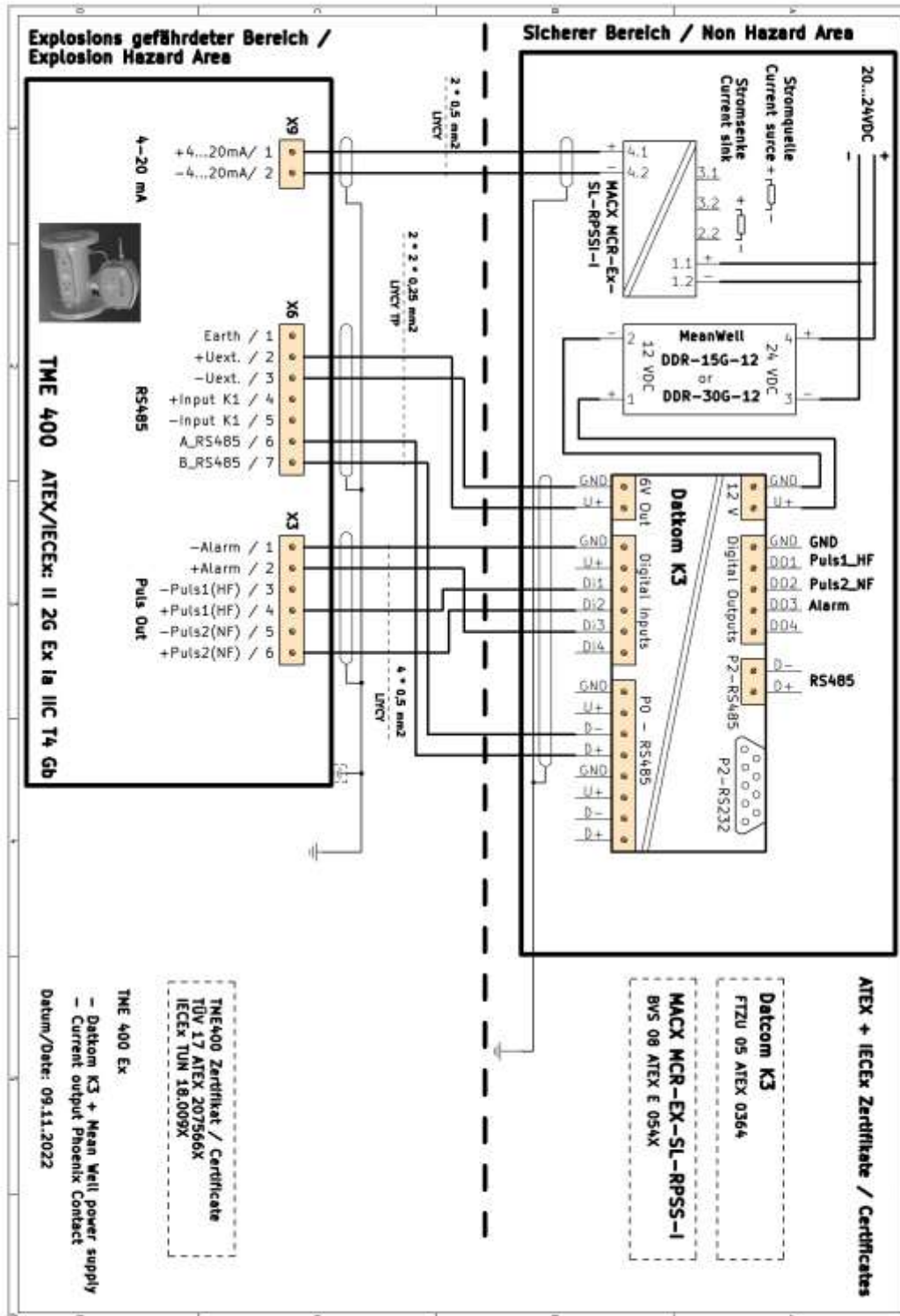

Ex version
with modules Pepperl+Fuchs / Meanwell / Datcom

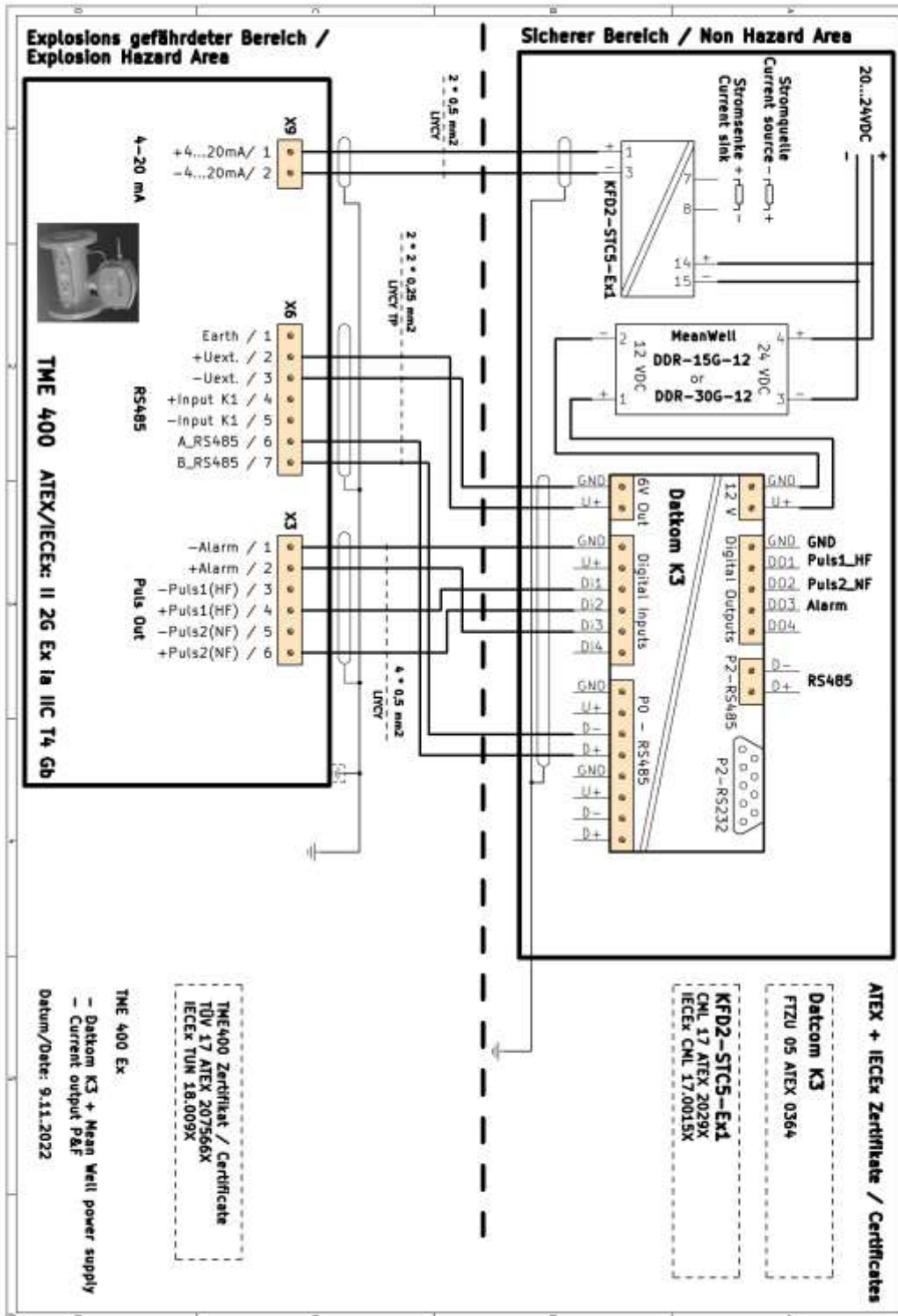

3 TME400

3.1 Display field

A single-line alphanumeric display with 12 characters enables representation of the data and measurements together with the short description or the unit.

50

Total flow volume

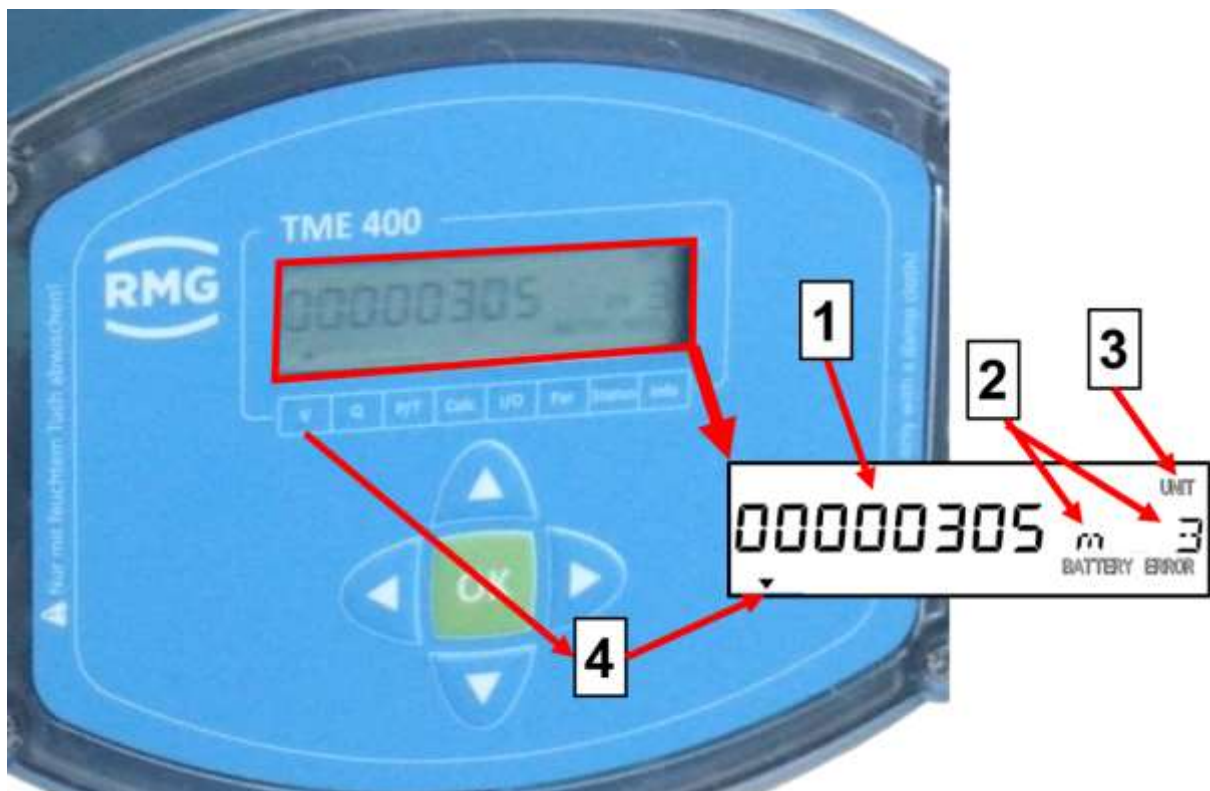

Figure 6: Display field

- | | | | |
|---|----------------------------|---|--------------------------|
| 1 | 8 characters for the value | 3 | Text: UNIT |
| 2 | Unit [m ³] | 4 | Display arrow for volume |

The LCD display and its operation are designed to save energy in order to enable battery-powered operation. The display can be impaired at temperatures below -25°C or above +60°C.

3.1.1 Display test

The display test is provided to ensure that all fields of the display function properly. For this purpose, please press and hold the up arrow and down arrow buttons (▲ and ▼) for more than 2 seconds. The following display appears while these buttons are held.

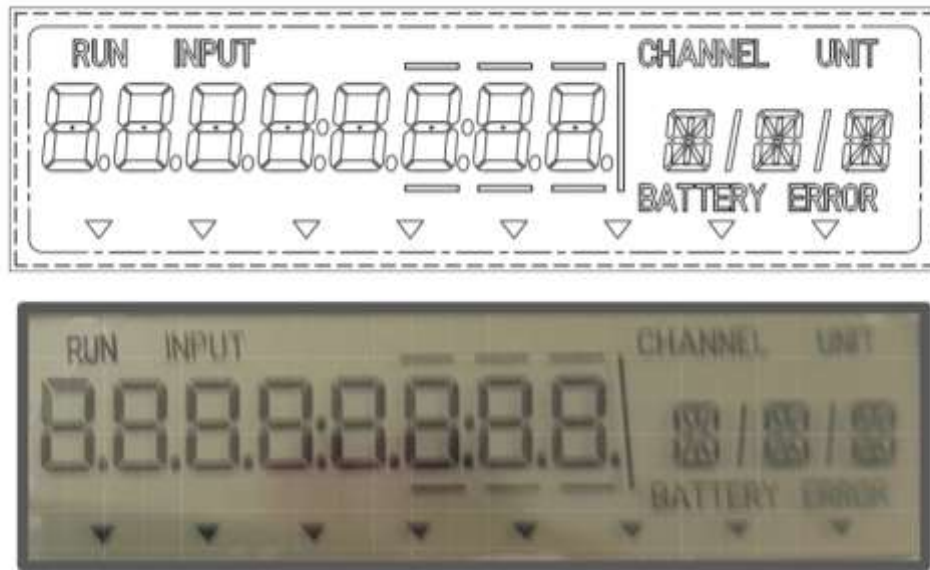

Figure 7: Display at display test

3.1.2 Reset

To reset the system, the voltage supply is interrupted and the TME400 is switched off for this period. For this purpose, the battery and any existing external voltage supply are disconnected. The program and operating parameters are not lost in the process and the meter statuses are saved.

3.1.3 Booting up

It may be necessary to re-boot the device in case of severe faults.

⚠ Caution

It is necessary to remove the seals, particularly the seal over the calibration button in order to boot up (see *Figure 8: Position of the calibration button*).

The TME400 must only be used for custody transfer with unbroken seal. Removal or damage to seals normally entails considerable expenses!

Re-application of seals must only be carried out by an officially recognized inspection authority or calibration officials!



Figure 8: Position of the calibration button

Note

**The current parameter settings and meter statuses are lost when re-booting!
They are reset to standard values.
Therefore, prior to booting up, read all parameters of the TME400.**

53

Proceed as follows to re-boot:

- Switch off the devices
- Press the "left ◀" and "right ▶" buttons simultaneously
- Switch on the voltage again
- Then, the text "del All" appears in the display.
- Release the depressed buttons.
- Press the calibration button with a thin pencil or small screwdriver.
- Now the device is booted up and the display shows "Boot".
- Then, "done" appears in the display and the totalizer status of the main totalizer is displayed.

Then, re-transmit all device parameters to the TME400 or enter the values from the test certificated.

Note

**The serial interface is set to 38400 Bps, 8N1, Modbus RTU after booting.
These are also the default values of RMGView^{TME}
(see *chapter 4.5 RMGViewTME*).**

3.1.4 Battery replacement

Note

The coordinate G24 (see *chapter 4.3.3.7 Error / type plate*) indicates the remaining battery capacity. If the remaining capacity falls below 10 %, a warning is generated.

54

In order to replace the battery, unscrew the large screw on the right side of the electronics with a large screwdriver or a coin.



Figure 9: Position of the battery housing

The meter is rotated in the next figure, showing the rear area in this figure below. Now, you can pull out the battery holder with battery on a handle.

The battery can be removed vertically in relation to the battery holder by pulling slightly. When installing the new battery, ensure that the polarity is retained for the new battery.

⚠ Danger

The battery must only be replaced in a non-explosive atmosphere. Ensure that the electronics are supplied with adequate ventilation with fresh air.

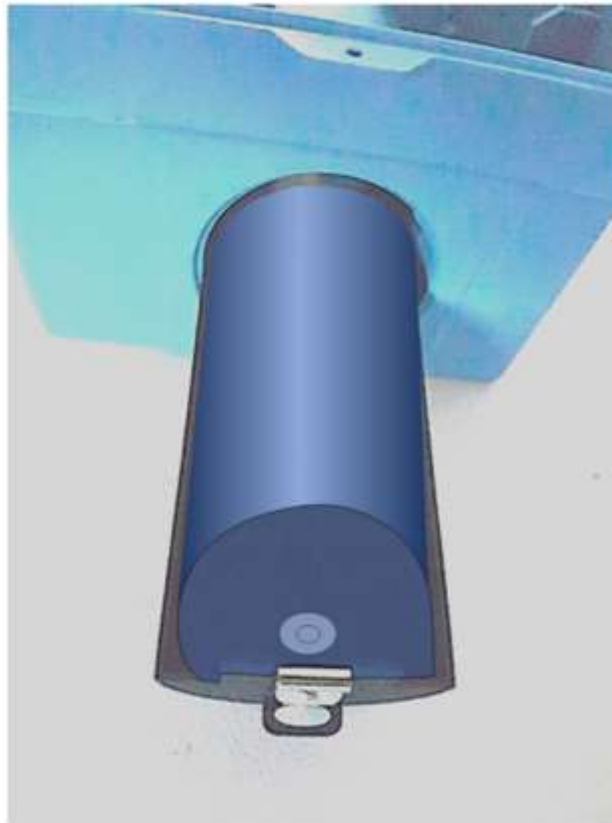

Figure 10: Battery holder

Note

The battery can be changed during operation.

- All readings of the counter(s) and all counting parameters are retained.
- After changing the battery, the current time and date must be entered again (coordinates X01 and X02; see *chapter 4.3.3.9 Archive*). In addition, the battery change must be indicated in coordinate G25. This updates the battery change date and sets the operating hours G26 to 0 and the battery capacity G24 to 100 %.

⚠ Danger

According to the type examination certificate, only the following battery types may be used in potentially explosive areas:

- Saft, type LS33600, 17 Ah or
- XENO, type XL 205-F, 19 Ah

56

Note

You can also have the battery replaced by the RMG Service department; please contact RMG for this purpose (see page 2).

Please only use the battery types intended by RMG. They are available as spare parts.

Also observe the information in the Disposal section on page 15.

4 Operation

4.1 Operation concept



57

Figure 11: Front panel

The concept of the operation is simple and easy to implement with knowledge of the coordinates.

4.1.1 Coordinate system

All configuration data, measurements and computed values are sorted in a table in a coordinate system which enables easy access. The coordinate system is divided into several columns, as shown on, in part, on the front panel (see *top* and *bottom*).





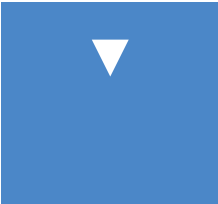

Figure 12: 8 columns of the coordinate system

With the cursor buttons (arrows)

58



you can reach each value by gently pressing the desired button in this coordinate system.

Keypad	Description	Effect
	Left arrow	Switches the column of the table from right to left
	Up arrow	Upward movement within the column of the table: You move from the last value of the list towards the first value. This is also used to adjust numbers (counting up).
	Down arrow	Downward movement within the column of the table: You move from the first value of the list towards the last value. This is used to adjust numbers (counting down).
	Right arrow	Switches the column of the table from left to right
	Function	The following functions are triggered by pressing: pressed < 2 seconds = display of the coordinate pressed > 2 seconds = switch to settings mode (see below)

4.1.2 Display and coordinate system

The main totalizer is displayed in normal operating mode. The other display values can be selected with the operating buttons. After approx. 1 minute, the TME400 switches back to the main totalizer.

If the display is dark, the TME400 is in energy-saving mode, where the display is completely switched off. The incoming pulses are processed and the outputs are actuated.

The display value is shown again by pressing any operating button.

Any arbitrary position in the coordinate system, which is identified by letters and numbers, can be reached with the arrow keys.

	A	B	C	D	E	F	G	H	X	Y	Z
01											
02					E02						
03											
04											
05											
06											
07											
...											



Example:

E02, for example, stands for the compression factor. This value is calculated after entry of relevant gas parameters via different gas models, which are listed below.

4.1.3 Parameter protection

Note

All custody-transfer parameters are protected by the (sealed) calibration button.

There are different access authorizations for the parameters with which unauthorized changes are suppressed. The different access rights are assigned to the coordinates

by a letter. They are shown in the coordinate list. The following access levels are used:

Access level	Access right
A	Display values, change not possible
N	Parameter for which no password is necessary for use
C	Code word Entry of a code word is necessary to change the parameter
E	Calibration button Custody-transfer variant TME400-VCF: Custody-transfer display values / parameters, use of the calibration button is necessary Non-custody-transfer variant TME400-VC: Entry of the code word is adequate <div style="border: 2px solid black; padding: 5px;"> <p>Note</p> <p>Enabling or disabling the code word or opening the calibration button creates an entry in the event archive (see below).</p> </div>

4.2 Programming

There are five buttons available on the front foil for programming of the TME400. Alternatively, you can carry out programming via the RMGView^{TME} operating software (see *chapter 4.5 RMGViewTME*).

4.2.1 Programming with the programming buttons

Basically, you proceed as follows for the programming:

- First check the protection status of the coordinate. When parameters are not protected, you can carry out changes, as described below without additional measures.
- With parameters protected by code word, you must enter it first in coordinate Z15. Please read how to make the entry as below.
- With parameters protected for custody-transfer applications, you must press the calibration button first.





⚠ Caution









It is necessary to remove the seals, particularly the seal over the calibration button in order to press the calibration button (see *Figure 8: Position of the calibration button*).

The TME400 must only be used for custody transfer with unbroken seal. Removal or damage to seals normally entails considerable expenses!

Re-application of seals must only be carried out by an officially recognized inspection authority or calibration officials!

The principle of the programming is shown based on the example of changing the output pulse factor:

- I. Move with the arrows (   ) to the position: A11
- II. Activate the calibration button (see *Figure 8: Position of the calibration button*)
- III. The blinking "INPUT" text appears above the displayed value in the display view.
- IV. Press **OK** for more than 2 seconds
- V. The value begins to blink at a position

- 62
- VI. With the  and  arrows, you can now increase or decrease the value at this position. For the values, after the "0", you also have "-1" available in order to enter negative values, if necessary.
 - VII. With the  and  arrows, you can move to a different position of the value and change it – as described in the point above.
 - VIII. An additional position is added when you move with the  and  before the displayed number.
For example, only the units digit is displayed. If you move in front of it, you will also have the tens position available as an entry.
 - IX. By pressing and holding the "right" button , the position of the decimal point is changed. After pressing and holding, the decimal point is inserted after the blinking digit.
 - X. By pressing and holding the "left" button , the entry can be canceled. If a change and/or entry is necessary, the entry must be restarted.
 - XI. When you have finished making an entry, you confirm it by briefly pressing .
 - XII. A plausibility check takes place and the result is displayed immediately.
 - XIII. If this check shows an implausible entry, "rAnGE" will be shown briefly in the display and the display jumps back to the original value.
 - XIV. If this check shows an plausible entry, "Good" will be shown briefly in the display and the value is adopted as a new value.
 - XV. Now you can – if necessary – change other parameters.
 - XVI. After about 1 minute without additional entries, the display returns to the display of the main totalizer.
 - XVII. By pressing the calibration, you close the further entry of custody-transfer parameters.
 - XVIII. After another minute without an entry, the change possibility is closed automatically.

Note

Some of the coordinates permit other settings as purely numerical values. However, these other entries are assigned numbers so that the adjustment can be carried out as described.

Example:



Current mode F02 can be deactivated or activated on various settings. This is adjusted as follows:

0	Off (default)
1	No errors
2	Error 3.5 mA
3	Error 21.8 mA
4	0 - 20mA

63

If F02 = "0" is selected for the coordinate, the current output is switched off.

Note

With some coordinates, a number is assigned fixed values. Instead of an adjustment with 0, 1, ..., these numerical values are shown directly. Changes are possible with the arrows  and , then the next higher or lower value is shown and can be adopted with .

Example:

Digital output 2 pulse width (coordinate A22) can adjust the pulse width to 3 different widths. The following values can be directly as an assignment:

- 20 ms
- 125 ms
- 250 ms

4.3 Equations in the TME400

The TME400 enables calculation of different values from the measured data and in the data entered in the TME400. For a better understanding, some variables and formula in this chapter are presented in advance; other equations and definitions of parameters are found in the *chapter 4.3.3. Coordinates in context*.

64

4.3.1 Variable description

Formula symbol	Units	Name
q_m	m ³ /h	Operating volume flow at measurement conditions
f_V	Hz	Frequency of the volume transmitter
K_V	l/m ³	Meter factor
V_m	m ³	Operating volume at measurement conditions
P_V	Nondimensional (1)	Volume pulse
K_{Z1}	m ³ /l	Meter factor (only for output contacts)
q_n	m ³ /h	Standard volume flow at normalized condition
V_n	m ³	Standard volume at normalized condition
$Z_u(p, T)$	Nondimensional (1)	Conversion factor
K_{Z2}	m ³ /l	Meter factor (only for output contacts)
p	bara, (barg, kg/cm ²)	Measured pressure (absolute)
p_n	bara, (barg, kg/cm ²)	Pressure in standard state (=1.01325 bar absolute)
T	°C	Measuring temperature
T_K	K	Measuring temperature in Kelvin
T_n	K	Temperature in standard state (= 273.15 K)
K	Nondimensional (1)	Compression factor
Z	Nondimensional (1)	Real gas factor
Z_n	Nondimensional (1)	Real gas factor in standard state (calculation for Z and Z_n takes place according to GERG-88 in accordance with G9)

4.3.2 Standard formula

Formula name	Formula	Reference chapter
Operating volume flow	$q_m = \frac{f_V}{K_V} * 3600 [\frac{m^3}{h}]$	4.3.3.2 Flow rate
Operating volume	$V_m = \frac{P_V}{K_V} \frac{1}{K_{Z1}}$	4.3.3.1 Volume / Meters
Compression factor	$K = \frac{Z}{Z_n}$	4.3.3.5 Analysis
Conversion factor	$Z_u(p,T) = \frac{p \cdot T_n}{p_n \cdot T_k \cdot K}$	4.3.3.5 Analysis
Standard volume flow	$q_n = \frac{f_V}{K_V} \cdot 3600 \cdot Z_u(p,T)$	4.3.3.2 Flow rate
Standard volume	$V_n = V_b \cdot Z_u(p,T) \cdot \frac{1}{K_{Z2}}$	4.3.3.1 Volume / Meters

65

Measuring and standard pressure are calculated as absolute pressure in the specified equations.

4.3.3 Coordinates in context

In the following, the coordinates which can be addressed with the TME400-VC and TME400-VCF turbine meters are shown. In the tables, the parameters which can be addressed with the TME400-VC are shown in light blue and the values which are additionally available with the version for custody-transfer applications, TME400-VCF, are shown in orange.

TME400-VC	Non-custody-transfer applications
TME400-VCF	Custody-transfer applications

4.3.3.1 Volume / Meters

Coordinate	Name	Description
A01	Standard volume	Volumes added up, corrected according to the equation above, plus the status and compression factor (see above).
A02	Operating volume	Volumes added up at the current (temperature and pressure) conditions.
A03	Standard volume error	Volumes added up under standard conditions; in these conditions a parameter was faulty or could not be determined (e.g. temporary failure of the temperature sensor, etc.)
A04	Operating volume error	Volumes added up under the present conditions; in these conditions a parameter was faulty or could not be determined (e.g. flow rates below or above the flow rate range, etc.)
A05	Uncorrected operating volume	Z26: If the characteristic correction is deactivated, A05 is not visible and cannot be adjusted. If a characteristic correction is activated, this characteristic curve correction is deactivated from 0 up to this value A05.
A06	Volume Start/Stop	Starts and stops a volume flow measurement
A07	Volume Reset	Sets the volume flow rate to 0
A10	Meter factor	<p>With the meter factor (pulse value), the corresponding operating value flow is calculated from the signal frequency of the sensor element in the meter electronics.</p> $q_m = \frac{f_V}{K_V} * 3600 \left[\frac{m^3}{h} \right]$ <p>The meter factor must be calibrated at the factory so that a direct meter display in cubic meters.</p> <div style="border: 1px solid black; padding: 5px; margin: 10px 0;"> <p>Note</p> <p>A change of this adjustment takes place in the area of responsibility of the operator.</p> </div> <p>After any change to the meter factor, calculation takes place with the new value immediately.</p> <p>The uninfluenced signal frequency of the sensor element is available at the HF output. The frequency range can be determined from the meter factor K and the minimum and maximum operating volume flow of the meter according to the formula:</p> $f_{V \min} = \frac{q_{m \min}}{3600} * K_V \quad f_{V \max} = \frac{q_{m \max}}{3600} * K_V$ <p><i>q_{m min}</i>: minimum operating volume flow</p>

		<p>$q_{m \max}$: maximum operating volume flow</p> <p>Example:</p> $q_{m \min} = 16 \text{ m}^3/\text{h}$ $q_{m \max} = 250 \text{ m}^3/\text{h}$ $K_V = 2362 \text{ pulses/m}^3$ $f_{V \min} = \frac{16 \text{ m}^3}{3600 \text{ s}} \cdot 2362 \frac{\text{Impulse}}{\text{m}^3} = 10,5 \text{ Hz}$ $f_{V \max} = \frac{250 \text{ m}^3}{3600 \text{ s}} \cdot 2362 \frac{\text{Impulse}}{\text{m}^3} = 164 \text{ Hz}$ <p>If measuring channel-1 or -2 fails, the HF output is switched off. The remaining pulse input is used for further conversion and counting into the disturbed volume counters. (With firmware versions older than 1.11 the High-Frequency (HF) output is switched off if measuring channel-1 fails.)</p>										
A11	Output pulse factor	The output pulse value indicates how many LF output pulses correspond to one m ³ (1 m ³).										
A12	Meter factor corrected	The meter can be adjusted by the operator, e.g. during calibration. As a display value, this value cannot be changed. This value is only visible if the Z27 characteristic correction is activated.										
A20	Display factor	<p>A20: Display factor for meters, including decimal places</p> <table border="1" data-bbox="627 1263 1441 1458"> <tr> <td>0.01</td> <td>Display with 2 decimal places</td> </tr> <tr> <td>0.1</td> <td>Display with 1 decimal place</td> </tr> <tr> <td>1</td> <td>Display without decimal places (default)</td> </tr> <tr> <td>10</td> <td>Display without decimal places</td> </tr> <tr> <td>100</td> <td>Display without decimal places</td> </tr> </table> <p>Example:</p> <p>If the factor is adjusted to 0.1, the meter status is displayed with a decimal place.</p> <div style="border: 2px solid black; padding: 5px;"> <p>Note</p> <p>If the factor is adjusted, for instance, to 10, the display value is displayed without a decimal place.</p> <p>You get the <u>actual</u> meter status by multiplying the display value by 10.</p> <p>This setting is marked with a "x 10" sticker (or it must be marked).</p> </div>	0.01	Display with 2 decimal places	0.1	Display with 1 decimal place	1	Display without decimal places (default)	10	Display without decimal places	100	Display without decimal places
0.01	Display with 2 decimal places											
0.1	Display with 1 decimal place											
1	Display without decimal places (default)											
10	Display without decimal places											
100	Display without decimal places											

A21	Digital output 2 mode	A21: Digital output 2 mode
		0 Operating volume
		1 Standard volume (default)
A22	Digital output 2 pulse width	A22 digital output 2 pulse width
		20 ms
		125 ms (default)
		250 ms

Coordinate	Name	Modbus register	Modbus access	Protection	Data type	Min.	Max.	Default	Unit
A01	Standard volume	300	W	E	uint32	0	99999999	0	m ³
A02	Operating volume	302	W	E	uint32	0	99999999	0	m ³
A03	Standard volume error	304	W	E	uint32	0	99999999	0	m ³
A04	Operating volume error	306	W	E	uint32	0	99999999	0	m ³
A05	Uncorrected operating volume	308	W	E	uint32	0	99999999	0	m ³
A06	Volume Start/Stop	310	W	N	uint32	0	99999999	0	m ³
A07	Volume Reset	312	W	N	uint32	0	99999999	0	m ³
A10	Meter factor	500	W	E	string12	*	*	1000.0	l/m ³
A11	Output pulse factor	506	W	E	float	0.01	100	1.0	l/m ³
A12	Meter factor corrected	508	R	A	float	-	-	1.0	l/m ³
A20	Display factor	510	W	E	menü16	0	4	2	
A21	Digital output 2 mode	511	W	E	menü16	0	1	1	
A22	Digit. output 2 pulse width	512	W	N	menü16	0	2	1	ms

4.3.3.2 Flow rate

Coordinate	Name	Description
B01	Standard flow rate	Flow value under standard conditions (see above)
B02	Operating flow rate	Flow rate under current operating conditions
B03	Frequency	Unchanged output value, frequency of Sensor 1.
B05	Min. flow rate	An alarm is generated below this flow rate
B06	Max. flow rate	An alarm is generated above this flow rate
B10, B11, B12, B13, B14,	Coefficients: A-2, A-1, A0, A1, A2	Z26: If the characteristic correction is deactivated, the additional parameters are not visible and cannot be adjusted. If a characteristic correction is activated (see Z26 below), a correction takes place with the factors in: B10: Factor for the characteristic correction B11: Factor for the characteristic correction

B15	Max. operating point deviation	B12: Factor for the characteristic correction B13: Factor for the characteristic correction B14: Factor for the characteristic correction B15: If the deviation of the corrected from the uncorrected characteristic at an operating point (or a range) is more than the adjusted value (2% here), the correction, is set to "0" for this operating point or operating range, which means a correction takes place.
B08	Leak flow volume limit	The flow rate is disregarded below this limit - i.e. it is set to 0
B09	Maximum time > Qug +	Indicates the maximum time until the flow rate (e.g. on start-up) reaches the measuring range (Qmin) after reaching the lower measuring limit (Qug). The flow rate measurement applies as defective during this time, but no error message is generated.

Note



There is no flow calculation with battery operation!

Coordinate	Name	Modbus register	Modbus access	Protection	Data type	Min.	Max.	Default	Unit
B01	Standard flow rate	318	R	A	float	-	-	*	N3/h
B02	Operating flow rate	320	R	A	float	-	-	*	m ³ /h
B03	Frequency	322	R	A	float	-	-	*	Hz
B05	Min. flow rate	521	W	E	float	*	*	0.0	m ³ /h
B06	Max. flow rate	523	W	E	float	*	*	1000.0	m ³ /h
B10	Coefficient A-2	530	W	E	float	*	*	0	Am2
B11	Coefficient A-1	532	W	E	float	*	*	0	Am1
B12	Coefficient A0	534	W	E	float	*	*	0	A0
B13	Coefficient A1	536	W	E	float	*	*	0	A1x10 ⁻⁴
B14	Coefficient A2	538	W	E	float	*	*	0	A2x10 ⁻⁸
B15	Max. dev. operating point	540	W	E	float	0.0	100.0	2.0	kkp
B08	Leak flow volume limit	527	W	E	float	*	*	*	m ³ /h
B09	Maximum time > Qug +	529	W	E	uint16	0	10000	10	s

4.3.3.3 Pressure

Coordinate	Name	Description
C01	Pressure	Currently available pressure
C02	Pressure mode	Pressure measurement transmitter (source of the pressure measurement)

70

		0	Specification (default, fixed value)	
		1	Wika TI-1	
		2	Endress + Hauser	
C03	Pressure Default	Default value of the pressure		
C04	Pressure Minimum	This value presents the lowest pressure value of the individual pressure transducer. An error is displayed if the pressure is below this limit.		
C05	Pressure Maximum	This value presents the highest pressure value of the individual pressure transducer. An error is displayed if the pressure is above this limit.		
C08	Pressure offset	The measured pressure value can be corrected. The offset enables a constant increase over the entire pressure measuring range, based on 1 bar of pressure (atmospheric pressure)		
C09	Pressure increase	The increase can be changed by the pressure increase factor based on the offset value.		
C10	Pressure sensor temperature	Display of the temperature of the pressure sensor.		
C11	Min. pressure sensor temperature	Temperature range (lower limit) within which the pressure sensor works "precisely".		
C12	Max. pressure sensor temperature	Temperature range (upper limit) within which the pressure sensor works "precisely". Outside of this range, the pressure value is interpreted as "incorrectly" measured.		

Coordinate	Name	Modbus register	Modbus access	Protection	Data type	Min.	Max.	Default	Unit
C01	Pressure	326	R	A	float	-	-	-	bar
C02	Pressure mode	555	W	E	menü16	0	2	0	
C03	Pressure specification	556	W	C ¹	float	0.0	100.0	1.0	bar

¹ "E" with firmware versions older than 1.11.

C04	Pressure Minimum	558	W	E	float	0.8	100.0	0.8	bar
C05	Pressure Maximum	560	W	E	float	0.8	100.0	2.5	bar
C07	Pressure offset	562	W	E	float	-0.5	0.5	0.0	
C08	Pressure increase	564	W	E	float	0.8	1.2	1.0	
C10	Pressure sensor temperature	566	R	E	float	-	-	-	°C
C11	Min. pressure sensor temperature	568	R	E	float	-	-	-	°C
C12	Max. pressure sensor temperature	570	R	E	float	-	-	-	°C

4.3.3.4 Temperature

Coordinate	Name	Description
D01	Temperature	Current temperature
D02	Temperature mode	Temperature measurement transmitter (source of the temperature measurement)
		0 Specification (default, fixed value)
		1 Pt1000 
D03	Temperature default	Default value of the temperature
D04	Temperature Minimum	This value represents the lowest temperature value of the temperature sensor at which the functionality of the TME400 is still guaranteed. An error is displayed if the temperature is below this limit.
D05	Temperature Maximum	This value represents the highest temperature value of the temperature sensor at which the functionality of the TME400 is still guaranteed. An error is displayed if the temperature is above this limit.
D06	Temperature moderation	The temperature value is moderated by means of averaging. A value of 0 corresponds to no moderation. A value of 0.99 causes heavy moderation.

D11	PT1000 resistance	Corrected resistance value of the Pt1000				
D12	PT1000 resistance un-corr.	Uncorrected resistance value of the Pt1000				
D30	Temperature (uncorrected)	Display of the uncorrected temperature measurement				
D35	Temperature setpoint 1	Set point 1 (lower value) for temperature adjustment				
D36	Temperature setpoint 2	Set point 2 (upper value) for temperature adjustment				
D37	Temp. actual value 1	Measured value at temperature set point 1				
D38	Temp. actual value 2	Measured value at temperature set point 2				
D41	Write temperature corr.	<p>Correction values with are adopted with "Yes" are calculated internally.</p> <div style="border: 1px solid black; background-color: yellow; padding: 5px; margin: 10px 0;"> <p>⚠ Caution</p> <p>Adoption of the correction changes the temperature characteristic measured in the factory and stored. Only perform this change if you are certain that you have detected a deviating temperature measurement.</p> <p>Of course, this correction is subject to the mandatory calibration.</p> </div> <table border="1" style="width: 100%; border-collapse: collapse;"> <tr> <td style="width: 40px; text-align: center;">0</td> <td>No (default)</td> </tr> <tr> <td style="text-align: center;">1</td> <td>Yes</td> </tr> </table> <div style="border: 1px solid black; background-color: blue; color: white; padding: 5px; margin: 10px 0;"> <p>Note</p> <p>Correction values displayed in the coordinates D08 (f0) and D09 (f1) are calculated internally. These correction values may only change within the scope of 0.9 to 1.1; otherwise there is a defect which must be corrected by RMG.</p> </div>	0	No (default)	1	Yes
0	No (default)					
1	Yes					

Coordinate	Name	Modbus register	Modbus access	Protection	Data type	Min.	Max.	Default	Unit
D01	Temperature	324	R	A	float	-	-	-	°C
D02	Temperature mode	587	W	E	menü16	0	1	0	
D03	Temperature default	588	W	C ²	float	-40.0	80.0	10.0	T-V
D04	Temperature Minimum	590	W	E	float	-40.0	80.0	-25.0	°C
D05	Temperature Maximum	592	W	E	float	-40.0	80.0	60.0	°C

² "E" with firmware versions older than 1.11.

D06	Temperature moderation	594		E	float	0.1	1.0	1.0	T-D
D11	PT1000 resistance	602	R	A	float	-	-	-	Ohm
D12	PT1000 resistance uncorr.	604	R	A	float	-	-	-	Ohm
D30	Temperature (uncorrected)	606	R	A	float	-	-	-	°C
D35	Temperature setpoint 1	616	W	N	float	-40.0	80.0	-10.0	°C
D36	Temperature setpoint 2	618	W	N	float	-40.0	80.0	50.0	°C
D37	Temp. actual value 1	620	W	N	float	-40.0	80.0	-10.0	°C
D38	Temp. actual value 2	622	W	N	float	-40.0	80.0	50.0	°C
D41	Write temperature corr.	628	W	E	menü16				

4.3.3.5 Analysis

Coordinate	Name	Description														
E01	Conversion factor	Conversion factor; see above														
E02	Compression factor	Compressibility (from AGA8, etc.); see above.														
E05	Calculation method	<p>The TME400 enables calculation of gas parameters, particularly the compression factor according to various methods. These methods must be adjusted in coordinate E05 with the corresponding number. Available for selection:</p> <table border="1"> <tr> <td>0</td> <td>Constant compression factor (default)</td> </tr> <tr> <td>1</td> <td>Gerg88S</td> </tr> <tr> <td>2</td> <td>AGA8 GROSS method 1</td> </tr> <tr> <td>3</td> <td>AGA8 GROSS method 2</td> </tr> <tr> <td>4</td> <td>AGA NX19-mod. (relative density)</td> </tr> <tr> <td>5</td> <td>AGA NX19-mod. (standard density)</td> </tr> <tr> <td>6</td> <td>GOST30319-2</td> </tr> </table> <p>The application of these calculations have been verified in the range of: Temperature: -25°C to +60°C Pressure: 0 bar to 40 bar (absolute)</p> <p>The calculation method also carries out checks on the approved input variables (e.g. temperature, pressure, standard calorific value, etc.). If the limits are exceeded, the calculation is performed with the default value of the compression factor. In this case, the device displays an error. The volumes are then summarized in the error totalizer.</p>	0	Constant compression factor (default)	1	Gerg88S	2	AGA8 GROSS method 1	3	AGA8 GROSS method 2	4	AGA NX19-mod. (relative density)	5	AGA NX19-mod. (standard density)	6	GOST30319-2
0	Constant compression factor (default)															
1	Gerg88S															
2	AGA8 GROSS method 1															
3	AGA8 GROSS method 2															
4	AGA NX19-mod. (relative density)															
5	AGA NX19-mod. (standard density)															
6	GOST30319-2															

Compression factor constant

The simplest option is to set to the compressibility to constant. This is correct if you always work with the same measuring gas and know the compression factor. Enter this compression factor in E02. The compression factor is set to "1" for an ideal gas (e.g. gases at low pressure).

Complete gas analyses are not necessary for any other gas models, but knowledge of additional gas parameters is necessary. Depending on the model, this must be entered in coordinates E07 to E12:

E07	Standard calorific value $H_o n$	kWh/m ³
E08	Standard density $Rho n$	kg/m ³
E09	Relative density DV	
E10	Percentage of carbon dioxide CO ₂	mol-%
E11	Percentage of nitrogen N ₂	mol-%
E12	Percentage of hydrogen H ₂	mol-%

GERG 88 S

This equation requires the following fixed input variables: standard calorific value (E07), standard density (E08), and the gas fractions (in mol%) of carbon dioxide (E10) and hydrogen (E12).

AGA 8 Gross Method 1

This calculation method corresponds to GERG 88 S taking into account the absence of hydrogen; E12, the percentage of H₂ = 0 -mol-%.

AGA 8 Gross Method 2

This equation requires the following fixed input variables: standard density (E08), as well as the gas fraction (in mol-%) of carbon dioxide (E10) and nitrogen (E11). The hydrogen fraction is assumed to be 0 mol-% in analogy to AGA8 Gross method 1.

AGA NX19-mod. (relative density)

This equation requires the following fixed input variables: Relative density (E09), standard calorific value (E07), and the gas fractions (in mol-%) of carbon dioxide (E10) and nitrogen (E11).

AGA NX19-mod. (standard density)

The input variables of this equation are: standard density (E08), standard calorific value (E07), and the gas fractions (in mol%) of carbon dioxide (E10) and nitrogen (E11).

GOST30319-2

This is a Russian standard to calculate the gas parameters. More details can be found in the Russian manual.

E06	Default compr. factor	Default value for compression factor
E07	Standard calorific value	Standard calorific value
E08	Standard density	Standard density

E09	Relative density	Relative density								
E10	Carbon dioxide	Fraction of carbon dioxide								
E11	Nitrogen	Fraction of nitrogen								
E12	Hydrogen	Fraction of hydrogen								
E20	Standard pressure selection	<p>Standard conditions In Germany, standard conditions at which gas parameters must be determined are defined. These standard conditions are for the pressure (E20) 1.01325 bar and the temperature (E21) 0°C. In addition, 25°C applies as a standard combustion temperature for determining the calorific value (E22).</p> <p>Selection of standard pressure</p> <table border="1"> <tr> <td>0</td> <td>1.01325 bar (default)</td> </tr> <tr> <td>1</td> <td>1.0 bar</td> </tr> </table>	0	1.01325 bar (default)	1	1.0 bar				
0	1.01325 bar (default)									
1	1.0 bar									
E21	Standard temperature selection	<p>Selection of standard temperature</p> <table border="1"> <tr> <td>0</td> <td>0° C (default)</td> </tr> <tr> <td>1</td> <td>15° C</td> </tr> <tr> <td>2</td> <td>15.56° C</td> </tr> <tr> <td>3</td> <td>20° C</td> </tr> </table>	0	0° C (default)	1	15° C	2	15.56° C	3	20° C
0	0° C (default)									
1	15° C									
2	15.56° C									
3	20° C									
E22	Standard combustion temp. selection	<p>Selection of the standard combustion temperature</p> <table border="1"> <tr> <td>0</td> <td>0° C</td> </tr> <tr> <td>1</td> <td>15° C</td> </tr> <tr> <td>2</td> <td>20° C</td> </tr> <tr> <td>3</td> <td>25° C (default)</td> </tr> </table> <div style="border: 1px solid black; padding: 5px; margin-top: 10px;"> <p>Note</p> <p>For the European area of application, the standard conditions are not uniform with respect to various pressure / temperature values. In the United States, conversions to the units "psi" and "°F" apply.</p> <p>In general, care should be taken, because the pressure / temperature values for the respective standard conditions may deviate from the German standard values. Disregard can result in significant conversion errors.</p> </div>	0	0° C	1	15° C	2	20° C	3	25° C (default)
0	0° C									
1	15° C									
2	20° C									
3	25° C (default)									

Coordinate	Name	Modbus register	Modbus access	Protection	Data type	Min.	Max.	Default	Unit
E01	Status coefficient	328	R	A	float	-	-	-	Supply
E02	Compressibility	633	R	A	float	-	-	1.0	K
E05	Calculation method	639	W	E	menü16	0	5	1.0	

E06	Compressibility default	640	W	C ³	float	0.1	10.0	1.0	K-V	
E07	Calorific value	642	W	C ³	float	0.0	100.0	11.5	Hon	
E08	Standard density	644	W	C ³	float	0.0	100.0	0.7440	rhv	
E09	Relative density	646	W	C ³	float	0.0	100.0	0.0	dv	
E10	Fraction of carbon dioxide	648	W	C ³	float	0.0	100.0	20.0	CO2	
76	E11	Nitrogen	650	W	C ³	float	0.0	100.0	25.0	N2
E12	Hydrogen	652	W	C ³	float	0.0	100.0	0.0	H2	
E20	Selection standard pressure	654	W	E	menü16	0	1	0		
E21	Selection standard temperature	655	W	E	menü16	0	3	0		
E22	Selection combustion temperature	656	W	E	menü16	0	3	0		

4.3.3.6 Current output

Coordinate	Name	Description																
F01	Current	Current to be output																
F02	Current mode	<p>Mode of the current output</p> <table border="1"> <tr><td>0</td><td>Off (default)</td></tr> <tr><td>1</td><td>No errors</td></tr> <tr><td>2</td><td>Error 3.5 mA</td></tr> <tr><td>3</td><td>Error 21.8 mA</td></tr> <tr><td>4</td><td>0 - 20mA</td></tr> </table> <p>If the current mode is set to "0", i.e. "Off", no parameters of the output other than parameter F02: current mode are visible and adjustable.</p>	0	Off (default)	1	No errors	2	Error 3.5 mA	3	Error 21.8 mA	4	0 - 20mA						
0	Off (default)																	
1	No errors																	
2	Error 3.5 mA																	
3	Error 21.8 mA																	
4	0 - 20mA																	
F03	Current source	<p>Source of the current output</p> <table border="1"> <tr><td>0</td><td>Specification (default)</td></tr> <tr><td>1</td><td>Operating flow rate</td></tr> <tr><td>2</td><td>Frequency</td></tr> <tr><td>3</td><td>Calibration 4mA</td></tr> <tr><td>4</td><td>Calibration 20mA</td></tr> <tr><td>5</td><td>Standard flow rate</td></tr> <tr><td>6</td><td>Temperature</td></tr> <tr><td>7</td><td>Pressure</td></tr> </table>	0	Specification (default)	1	Operating flow rate	2	Frequency	3	Calibration 4mA	4	Calibration 20mA	5	Standard flow rate	6	Temperature	7	Pressure
0	Specification (default)																	
1	Operating flow rate																	
2	Frequency																	
3	Calibration 4mA																	
4	Calibration 20mA																	
5	Standard flow rate																	
6	Temperature																	
7	Pressure																	

³ "E" with firmware versions older than 1.11.

F04	Phys. Minimum value	Current output phys. Minimum value (required for display in RMGView ^{TME})
F05	Phys. Maximum value	Current output phys. Maximum value (required for display in RMGView ^{TME})
F06	Current specification	Specification value for the current output (for testing purposes)
F07	Current moderation	The current output is damped by averaging. A value of 0 corresponds to no damping. A value of 0.99 causes strong averaging.
F10	Calibration value 4mA	Calibration: Current value 4mA (after activation of current source)
F11	Calibration value 20mA	Calibration: Current value 20mA (after activation of current source)
F12	Module serial number	Serial number of the current module

Coordinate	Name	Modbus register	Modbus access	Protection	Data type	Min.	Max.	Default	Unit
F01	Current	330	R	A	float	-	-	-	mA
F02	Current mode	657	W	N	menü16	0	4	0	
F03	Current source	658	W	N	menü16	0	7	0	
F04	Figure below	659	W	N	float	-	-	0.0	
F05	Figure above	661	W	N	float	-	-	1000.0	
F06	Current specification	663	W	N	float	0.0	25.0	12.0	mA
F07	Current moderation	665	W	N	float	0.0	0.99	0.7	I-D
F10	Calibration value 4mA	667	W	N	float	0.0	25.0	4.0	mA
F11	Calibration value 20mA	669	W	N	float	0.0	25.0	20.0	mA
F12	Module serial number	671	W	N	string8	-	-	0000 0000	SN

4.3.3.7 Error / type plate

Coordinate	Name	Description
G01	Current error	Identifies the current error
G02	Software version	Shows the version number of the firmware in the TME400.
G04	Serial number	Serial number of the TME400
G05	Firmware checksum	Shows the checksum of the firmware (important for TME400-VMF and TME400-VCF in custody-transfer applications)
G06	Measuring point	Possibility of numerical identification for the measuring point
G10	Standard pressure	Display of the standard pressure setting
G11	Pressure range min.	Display of the minimum of the pressure range Value range of the pressure sensor (chapter 5.1.2.4 Pressure transducer) or customer setting C04)

G12	Pressure range max.	Display of the maximum of the pressure range (chapter 5.1.2.4 Pressure transducer) or customer setting C05)
G13	Pressure sensor serial number	Serial number of the pressure sensor
G14	Standard temperature	Display of the standard pressure setting
G17	Temperature sensor serial number	Serial number of the temperature sensor
G18	Meter number	Number of the turbine meter
G21	CRC metrological Param. EEPROM	CRC of metrological parameters EEPROM
G23	Date of Battery Exchange	Date of battery exchange
G24	Remaining Battery Capacity	Remaining capacity of the battery
G25	Battery Change	0 No (default)
		1 Yes
G26	Operating Hours	Operating hours
G19	Meter size	Meter size (G ..)
G20	Date of last battery replacement	Shows the date of the last battery replacement

Coordinate	Name	Modbus register	Modbus access	Protection	Data type	Min.	Max.	Default	Unit
G01	Current error	675	R	A	uint16	-	-	0	ERR
G02	Software version	676	R	A	float	-	-	*	Rev
G04	Serial number	680	W	E	int32	0	99999999	0I	SNo
G05	Firmware checksum	682	R	A	int16	-	-	*	CRC
G06	Measuring point	314	W	A	uint32	*	*	0	Rev
G10	Standard pressure	683	R	A	float	-	-	1.0	bar
G11	Pressure range min.	685	R	A	float	-	-	0.7	bar
G12	Pressure range max.	687	R	A	float	-	-	2.0	bar
G13	Pressure sensor serial number	689	R	A	string12	-	-	*	---
G14	Standard temperature	695	R	A	float	-	-	273.15	TN
G17	Temperature sensor serial number	697	W	E	int32	*	*	9999 9999	TNo
G18	Meter number	699	W	E	int32	*	*	9999 9999	MNo
G21	CRC metrological Param. EEPROM	804	R	A	string8	-	-	CALC	Hex
G23	Date of Battery Exchange	705	W	C	string8	-	-	010117	Bat
G24	Remaining Battery Capacity	790	R	A	uint16	-	-	100	%
G25	Battery Change	791	W	C	menu16	0	1	0	-

G26	Operating Hours	792	R	A	uint32	-	-	0	h
G19	Meter size	701	W	E	string8	*	*	4-16000	G
G20	Batter replacement date	705	W	C	int32	*	*	0101 2014	Bat

4.3.3.8 RS-485 interface

Coordinate	Name	Description
H01	RS-485 Baud rate	2400 Bps
		9600 Bps
		19200 Bps
		38400 Bps (default)
H02	RS-485 parameter	0 8N1 (default)
		1 8E1
		2 8O1
		3 7N1
		4 7E1
		5 7O1
H03	RS-485 protocol	0 Off
		1 Modbus RTU (default)
		2 Modbus ASCII
H04	Modbus ID	Modbus device address (default = 1).
H05	Modbus register offset	The offset is defined as 1 by RMG.

Coordinate	Name	Modbus register	Modbus access	Protection	Data type	Min.	Max.	Default	Unit
H01	RS-485 Baud rate	709	W	N	menu16	0	3	3	Bps
H02	RS485 parameter	710	W	N	menu16	0	5	0	
H03	RS485 protocol	711	W	N	menu16	0	2	1	
H04	Modbus ID	712	W	N	uint16	1	250	1	MID
H05	Modbus register offset	713	W	N	uint16	0	10000	1	Mof

4.3.3.9 Archive

Coordinate	Name	Description																																								
X01	Time	Direct entry of the current time as described above.																																								
X02	Date	Direct entry of the current date as described above.																																								
X10	Delete parameter archive	<table border="1"> <tr> <td>0</td> <td>No (default)</td> </tr> <tr> <td>1</td> <td>Yes</td> </tr> </table>	0	No (default)	1	Yes																																				
0	No (default)																																									
1	Yes																																									
X11	Param. archive fill level	Display value																																								
X14	Delete event archive	<table border="1"> <tr> <td>0</td> <td>No (default)</td> </tr> <tr> <td>1</td> <td>Yes</td> </tr> </table>	0	No (default)	1	Yes																																				
0	No (default)																																									
1	Yes																																									
X15	Event archive fill level	Display value																																								
X16, X17, X18, X19, X20, X21, X22, X23	Measurement archive mode	<table border="1"> <tr> <td>0</td> <td>Off</td> </tr> <tr> <td>1</td> <td>On (default)</td> </tr> </table> <p>If measurement archive mode is activated, the following archives are visible and can be adjusted and deleted as necessary.</p> <p>Minutes archive</p> <table border="1"> <tr> <td>X17 interval</td> <td>0</td> <td>15 minutes (default)</td> </tr> <tr> <td></td> <td>1</td> <td>30 minutes</td> </tr> <tr> <td></td> <td>2</td> <td>60 minutes</td> </tr> <tr> <td>X18 delete</td> <td>0</td> <td>No (default)</td> </tr> <tr> <td></td> <td>1</td> <td>Yes</td> </tr> <tr> <td>X19 fill level</td> <td colspan="2">Display value</td> </tr> </table> <p>Day archive</p> <table border="1"> <tr> <td>X20 delete</td> <td>0</td> <td>No (default)</td> </tr> <tr> <td></td> <td>1</td> <td>Yes</td> </tr> <tr> <td>X21 fill level</td> <td colspan="2">Display value</td> </tr> </table> <p>Month archive</p> <table border="1"> <tr> <td>X22 delete</td> <td>0</td> <td>No (default)</td> </tr> <tr> <td></td> <td>1</td> <td>Yes</td> </tr> <tr> <td>X23 fill level</td> <td colspan="2">Display value</td> </tr> </table>	0	Off	1	On (default)	X17 interval	0	15 minutes (default)		1	30 minutes		2	60 minutes	X18 delete	0	No (default)		1	Yes	X19 fill level	Display value		X20 delete	0	No (default)		1	Yes	X21 fill level	Display value		X22 delete	0	No (default)		1	Yes	X23 fill level	Display value	
0	Off																																									
1	On (default)																																									
X17 interval	0	15 minutes (default)																																								
	1	30 minutes																																								
	2	60 minutes																																								
X18 delete	0	No (default)																																								
	1	Yes																																								
X19 fill level	Display value																																									
X20 delete	0	No (default)																																								
	1	Yes																																								
X21 fill level	Display value																																									
X22 delete	0	No (default)																																								
	1	Yes																																								
X23 fill level	Display value																																									
X24	Delete all Archives	<p>All archives</p> <table border="1"> <tr> <td>X24 delete</td> <td>0</td> <td>No (default)</td> </tr> <tr> <td></td> <td>1</td> <td>Yes</td> </tr> </table>	X24 delete	0	No (default)		1	Yes																																		
X24 delete	0	No (default)																																								
	1	Yes																																								
X12	Delete parameter archive (E)	<table border="1"> <tr> <td>0</td> <td>No (default)</td> </tr> <tr> <td>1</td> <td>Yes</td> </tr> </table>	0	No (default)	1	Yes																																				
0	No (default)																																									
1	Yes																																									
X13	Parameter archive (E) fill level	Display value																																								

Coordinate	Name	Modbus register	Modbus access	Protection	Data type	Min.	Max.	Default	Unit
X01	Time	714	W	E	string8				T
X02	Date	717	W	E	string8				D
X10	Delete parameter archive	722	W	E	menu16	0	1	0	
X11	Parameter archive fill level	723	R	A	uint16	-	-	0	%
X14	Delete event archive	726	W	E	menu16	0	1	0	
X15	Event archive fill level	727	R	A	uint16	-	-	0	%
X16	Measurement archive mode	728	W	E	menu16	0	1	1	
X17	Minute archive interval	729	W	E	menu16	0	2	0	
X18	Delete minute archive	730	W	E	menu16	0	1	0	
X19	Minute archive fill level	731	R	A	uint16	-	-	0	%
X20	Delete day archive	732	W	E	menu16	0	1	0	
X21	Day archive fill level	733	R	A	uint16	-	-	0	%
X22	Delete month archive	734	W	E	menu16	0	1	0	
X23	Month archive fill level	735	R	A	uint16	-	-	0	%
X24	Delete all archives	812	W	E	menu16	0	1	0	
X12	Delete parameter archive (E)	724	W	E	menu16	0	1	0	
X13	Parameter archive (E) fill level	725	R	A	uint16	-	-	0	%

81

Further information about the archives can be found in *Appendix B Structure of the archives*.

4.3.3.10 Settings

Coordinate	Name	Description
Z04	X:Y maximum pulse error	A differential circuit compares the metered pulse of measuring and comparison channels alternately. Every deviation is counted internally. An alarm is generated if the adjusted limit value is exceeded. The failure counter is reset to 0 for each new measurement or after the maximum number of pulses (Z05) is reached.
Z05	X:Y maximum pulse	see above
Z10	Error register 1	Display value

Z11	Error register 2	Display value																		
Z12	Status register 1	Display value																		
Z13	Status register 2	Display value																		
Z15	Code word release	<div style="border: 2px solid black; padding: 5px;"> <p>Note</p> <p>The code word for the TME400 is: 1 2 3 4</p> <p>This is always displayed as " **** " in the parameter archive.</p> </div> <p>With entry of this code word, the protected parameters can be changed.</p>																		
Z16	Change code word	A new password can be defined here.																		
Z17	Device type	<table border="1"> <tr><td>0</td><td>TME400-VM (default)</td></tr> <tr><td>1</td><td>TME400-VC</td></tr> <tr><td>2</td><td>TME400-VMF (MID)</td></tr> <tr><td>3</td><td>TME400-VCF (MID)</td></tr> </table>	0	TME400-VM (default)	1	TME400-VC	2	TME400-VMF (MID)	3	TME400-VCF (MID)										
0	TME400-VM (default)																			
1	TME400-VC																			
2	TME400-VMF (MID)																			
3	TME400-VCF (MID)																			
Z24	Display active max.	<table border="1"> <tr><td>0</td><td>1 minute (default)</td></tr> <tr><td>1</td><td>5 minutes</td></tr> <tr><td>2</td><td>60 minute test</td></tr> </table> <p>The time during which the display is active for tests is selected as 60 minutes. In general, however, it must be observed that higher energy consumption is associated with this time, so this time should be selected as short as possible, if possible.</p>	0	1 minute (default)	1	5 minutes	2	60 minute test												
0	1 minute (default)																			
1	5 minutes																			
2	60 minute test																			
Z25	Volume metering mode	<table border="1"> <tr><td>0</td><td>1-channel without errors (default)</td></tr> <tr><td>1</td><td>1-channel stop on error</td></tr> <tr><td>2</td><td>1-channel run on error</td></tr> <tr><td>3</td><td>1-channel start / stop</td></tr> <tr><td>4</td><td>1-channel reset</td></tr> <tr><td>5</td><td>2-channel stop on error</td></tr> <tr><td>6</td><td>2-channel run on error</td></tr> <tr><td>7</td><td>2-channel without X:Y error</td></tr> <tr><td>8</td><td>1 Channel Start/Stop Mode 2</td></tr> </table> <p>With 1-channel measurements (0, 1, 2, 3, 4), the Z04 and Z05 pulse comparison is not activated. An entry for sensor type 2 is superfluous and has <u>no</u> further significance.</p> <p>Volume metering mode 8: 1 Channel Start/Stop Mode 2 If the external contact input 3 is closed (or opened), this additional mode 2 triggers a start (or stop) for the start/stop totalizer during this time.</p>	0	1-channel without errors (default)	1	1-channel stop on error	2	1-channel run on error	3	1-channel start / stop	4	1-channel reset	5	2-channel stop on error	6	2-channel run on error	7	2-channel without X:Y error	8	1 Channel Start/Stop Mode 2
0	1-channel without errors (default)																			
1	1-channel stop on error																			
2	1-channel run on error																			
3	1-channel start / stop																			
4	1-channel reset																			
5	2-channel stop on error																			
6	2-channel run on error																			
7	2-channel without X:Y error																			
8	1 Channel Start/Stop Mode 2																			

		<p>The LF output and the current output are deactivated for this period (4 mA) and no pulses are output (main totalizers stop). In case of an error, the pulses are counted in the error totalizers and current and pulses are output.</p>						
Z26	Characteristic correction	<p>If the TME400 is supplied with a current supply, the TME400 enables a characteristic correction via a polynomial. This correction must be activated with coordinate Z26. With this polynomial correction, the corresponding percentage deviations of the turbine meter from a reference standard are determined for fixed percentage flow rate values. From these deviations, a polynomial function which ideally reflects the curve running through these points is calculated. The coefficients of the polynomial A-2, A-1, A0, A1 and A2 are adjusted by the manufacturer in the coordinates B10 to B14 or can be entered there when the manufacturer of the turbine meter provides these values.</p> <div style="border: 1px solid black; padding: 5px; margin-top: 10px;"> <p>Note</p> <p>The HF output pulses (X3 pulse 1) are always uncorrected! With an active characteristic curve correction, no HF pulses are output.</p> </div> <table border="1" style="margin-top: 10px;"> <tr> <td>0</td> <td>Off (default)</td> </tr> <tr> <td>1</td> <td>On</td> </tr> </table>	0	Off (default)	1	On		
0	Off (default)							
1	On							
Z27	Sensor type 1	<table border="1"> <tr> <td>0</td> <td>Reed sensor</td> </tr> <tr> <td>1</td> <td>Wiegand sensor (default)</td> </tr> <tr> <td>2</td> <td>External</td> </tr> </table>	0	Reed sensor	1	Wiegand sensor (default)	2	External
0	Reed sensor							
1	Wiegand sensor (default)							
2	External							
Z28	Sensor type 2	<p>Settings are possible, but only make sense in 2-channel operation. Settings changed here have no effect in 1-channel operation,</p> <table border="1"> <tr> <td>0</td> <td>Reed sensor</td> </tr> <tr> <td>1</td> <td>Wiegand sensor (default)</td> </tr> <tr> <td>2</td> <td>External</td> </tr> </table>	0	Reed sensor	1	Wiegand sensor (default)	2	External
0	Reed sensor							
1	Wiegand sensor (default)							
2	External							
Z29	Volume unit	<table border="1"> <tr> <td>0</td> <td>m³ (Default)</td> </tr> <tr> <td>1</td> <td>cf</td> </tr> </table>	0	m ³ (Default)	1	cf		
0	m ³ (Default)							
1	cf							

Coordinate	Name	Modbus register	Modbus access	Protection	Data type	Min.	Max.	Default	Unit
Z04	X:Y maximum pulse error	775	W	E	uint16	1	10000	10	X
Z05	X:Y maximum pulse	776	W	E	uint16	1	10000	10000	Y
Z10	Error register 1	332	R	A	int16	-	-	*	Err
Z11	Error register 2	333	R	A	int16	-	-	*	Err

Z12	Status register 1	334	R	A	int16	-	-	*	Sta	
Z13	Status register 2	335	R	A	int16	-	-	*	Sta	
Z15	Code word release	777	W	N	uint16	1	9999	0	COD	
Z16	Change code word	778	W	C	int16	1	9999	1234	C-V	
Z17	Device type	779	W	E	menu16	0	3	0		
84	Z24	Display active max.	780	W	N	menu16	0	2	0	
Z25	Volume metering mode	781	W	E	menu16	0	7	0		
Z26	Characteristic correction	782	W	E	menu16	0	1	0		
Z27	Sensor type 1	783	W	E	menu16	0	2	1		
Z28	Sensor type 2	784	W	E	menu16	0	2	1		
Z29	Volume unit	785	W	E	menu16	0	1	0		

Note

If the parameter is not dimensioned, the text in the "Unit" column is shown in the display of the TME400 to the right under UNIT.

4.4 Special settings

4.4.1 Configuration of the current output

The connection of external devices to the current output of the meter is to be carried out as described in chapter 2.1 *Electrical connections*.

The parameters are then set in column 'F Current output' of the coordinate matrix as follows:

85

1. In coordinate **F-02** (current mode) select the operating mode of the current output:
 - 0: Off (default)
 - 1: 4-20mA - current is always calculated from the physical value
 - 2: 4-20mA - below the minimum value output of 3.5 mA
 - 3: 4-20mA - above the maximum value output of 21.8 mA.
 - 4: 0-20mA
2. In coordinate **F-03** (current source) select the value for output:
 - 0: Fixed value (default)
 - 1: Operating flow rate
 - 2: Sensor frequency
 - 3: Fixed value of 4mA for calibration
 - 4: Fixed value of 20mA for calibration
 - 5: Standard flow rate
 - 6: Temperature
 - 7: Pressure
3. In coordinate **F-04** (physical minimum) enter the lower limit for the physical value at which 0 or 4 mA should be output.
4. In coordinate **F-05** (physical maximum) enter the upper limit for the physical value eintragen, at which 20 mA should be output.
5. In **F-06** (current specification) a fixed value can be entered for the current which is output with the entry 0 in coordinate F-02.
6. In **F-07** (damping) the inertia of the output can be set with values from 0 (minimum) to 0.99 (maximum).

4.5 RMGView^{TME}

The RMGView^{TME} software also provides an additional possibility of parameter input. This software offers you additional options in combination with the TME400.

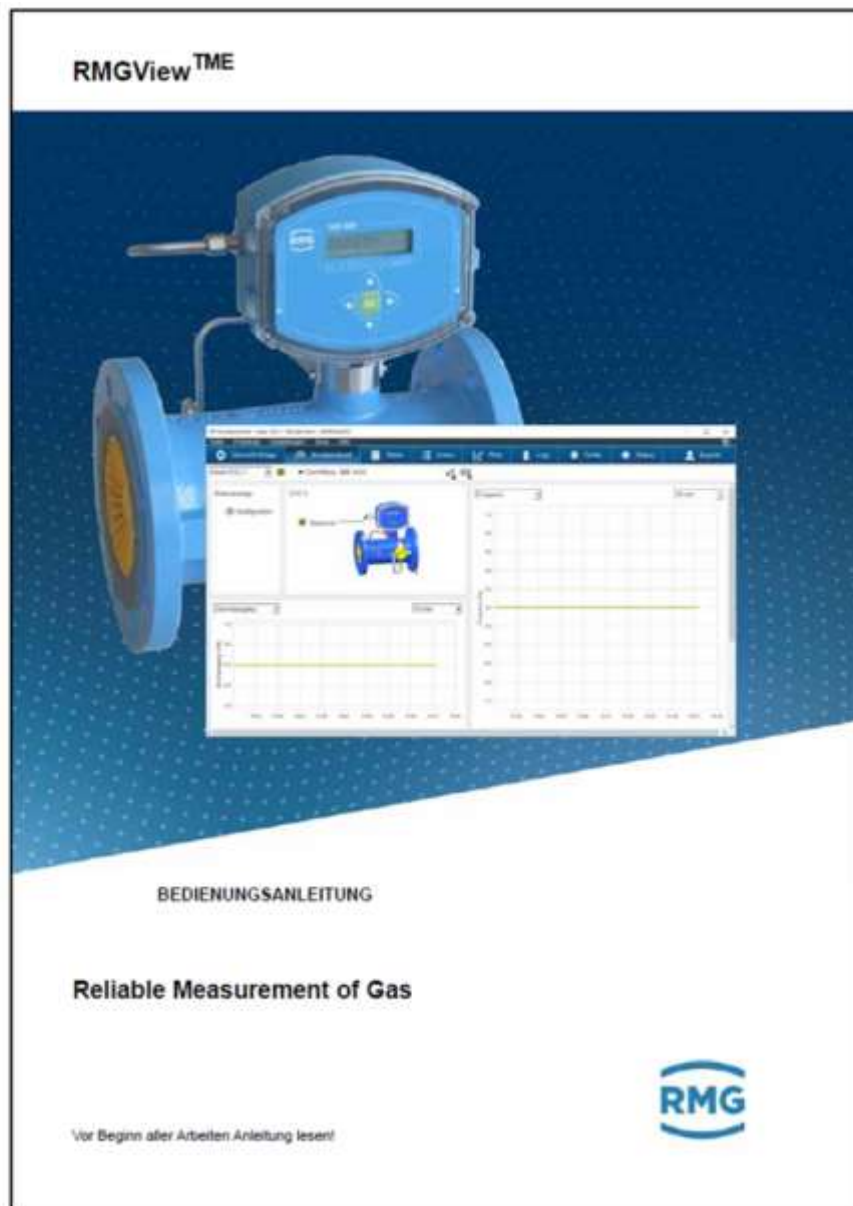

Figure 13: RMGView^{TME} software

5 Technical data

5.1.1 Device types

Reed or transistor (with connected turbine meter)	
Pulse input	Reed or transistor
Current output	Current loop connection (current supply via this current output possible)
Wiegand (with connected turbine meter)	
Use	Direct installation on the TME400 turbine meter instead of the meter head
Pulse input	Wiegand
Current output	Current loop connection (current supply via this current output possible)

87

5.1.2 Inputs

Volume	
Reed	
Pulse frequency	0 Hz ... 4 Hz
Pulse width	≥ 20 ms
Voltage	low: ≤ 0.9 V high: ≥ 2.2 V
Wiegand	
Pulse frequency	0 Hz ... 400 Hz; with battery operation
Pulse width	≥ 5 μ s
Voltage	min. 1 V max. 5 V (determined by sensor)

5.1.2.1 Power supply

Power supply	
Internal battery	Lithium cell 3.6 V; in the device (battery pack)
External 6-24 V DC via X6	via U_{ext} + battery pack (NON-Ex)
External 6-10.5 V DC via X6	via U_{ext} + battery pack (Ex)
External 6-24 V DC via X9	via current loop connection + battery pack

5.1.2.2 Pulse In measuring inputs (sensor 1 / 2)**Note**

For Ex connection values, see approval

88

The cable length to the Wiegand sensor must not exceed 15 m. With use of an external pressure transducer, this maximum length is limited to 3 m.

5.1.2.3 Temperature input

The temperature sensor is connected at the factory; the Ex connection values are met in this process.

Measuring range	-25°C to 60°C
Resolution	± 0.2 °C

5.1.2.4 Pressure transducer

The pressure sensor is connected at the factory; the Ex connection values are met in this process.

Wika TI-1

Measuring ranges (absolute pressure)

- 0.8 bar to 2.5 bar
- 0.8 bar to 6.0 bar
- 2.0 bar to 10.0 bar
- 4.0 bar to 20.0 bar

Accuracy (at reference conditions according to IEC 61298-1)

- ≤ ±0.25 % of span

Endress+Hauser

Not yet released.

5.1.3 Outputs

Non-Ex	
U_{min}	5 V
$U_{max} (U_i)$	30 V
I_{max}	100 mA

For use of the TME400 in hazardous areas the values for the HF, LF and alarm output must be taken from the ATEX certificate.

89

5.1.4 Digital interface

RS-485 data interface	
U_{ext}	6.0 – 24 V

For use of the TME400 in hazardous areas the values must be taken from the ATEX certificate.

Note

When using the RS485 interface, the device must be supplied with power via U_{ext} .

Note

In an Ex version, the connection must only be made to a certified, intrinsic safe current circuit.

The Ex-relevant connection values are specified in the approval.

5.1.5 Current loop connection

Current loop connection	
$U_{ext} (min)$	12 V
$U_{ext} (max)$	28 V
I_{min}	3.5 mA
I_{max}	23 mA
External resistance (max.)	See: <i>Figure 14: Load depending on feeder supply</i>

Current output for	
- minimum flow rate	4 mA
- maximum flow rate	20 mA
- alarm	3.5 mA or 21.8 mA
Current output accuracy better than 1% of the end value	

90

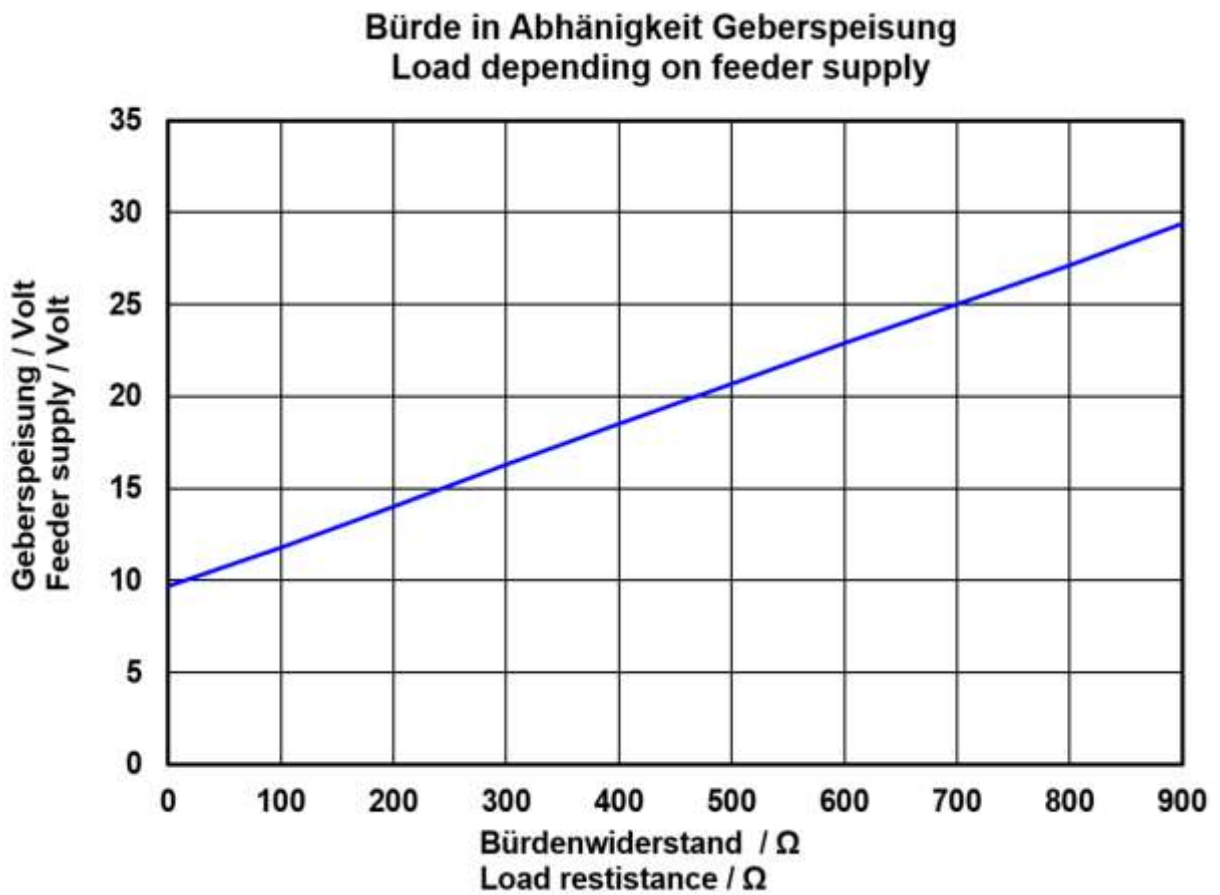

Figure 14: Load depending on feeder supply

For use of the TME400 in hazardous areas the values must be taken from the ATEX certificate.

5.1.6 Cable

Signal cables (LF output, HF output, current loop connection, control input) must have 2 or more wires twisted in pairs and shielded (LiYCY-TP).

4-wire, twisted and shielded cables (LiYCY-TP) must be used for the data cables (RS-485).

The shielding must be grounded on both ends - on the TME400, as described in the *section 5.1.7. Cable connection*.

Cable cross-sections of 0.5 mm² are recommended. Due to the cable screw connection, the outer diameter of the cable must be between 4.5 and 6.5 mm.

Caution

The maximum cable length is limited when used in hazardous areas due to the limit values for intrinsically safe current circuits and depending on the inductivity and capacity of the cable.

5.1.7 Cable connection

Connect the shield on both ends to the cable screw connections on the outside of the housing, as shown in the figure below:

- Unscrew the union nut.
- Pull the terminal insert out of the plastic.
- Slide the cable end through the union nut and the terminal insert and bend the shielding back.
- Plug the terminal insert back into the connecting piece.
- Tighten the union nut.
- Every Ex signal circuit must be routed with a dedicated cable which must be guided through the appropriate PG screw coupling.

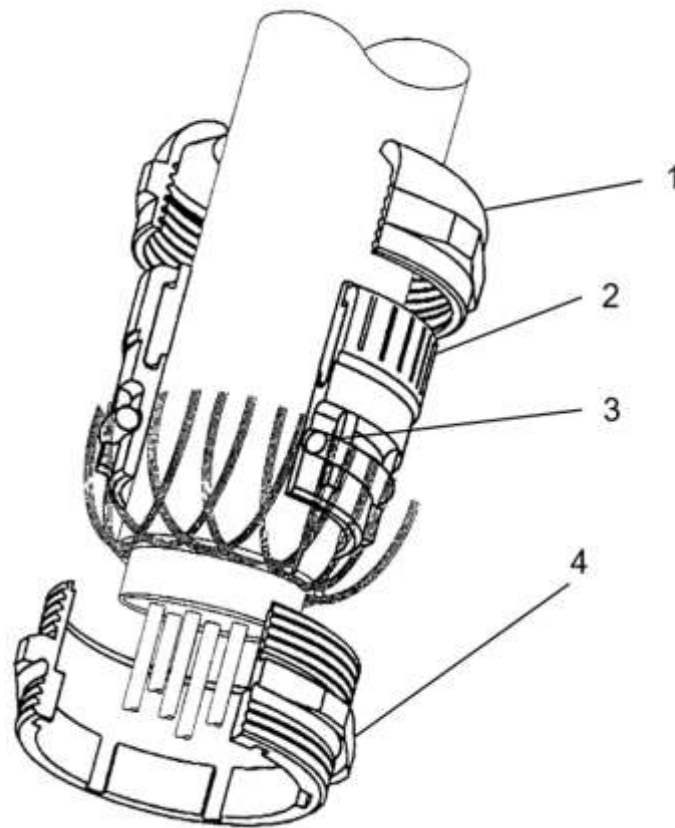

Figure 15: Terminal screw connection

- | | | | |
|---|-----------------|---|------------------|
| 1 | Coupling nut | 3 | O-ring |
| 2 | Terminal insert | 4 | Connecting piece |

5.1.8 Ground

Note

To avoid measuring errors due to electromagnetic interference, the meter housing must be grounded with the ground connection on the lower right section of the housing (see *Figure 16: Grounding the meter*).

Minimum cable cross-section:

- length of up to 10 m: 6 mm²
- length of 10 m or higher: 10 mm²



Figure 16: Grounding the meter

In the process, a conductive connection between the TME400 and the pipeline must be provided as shown in the figure below.

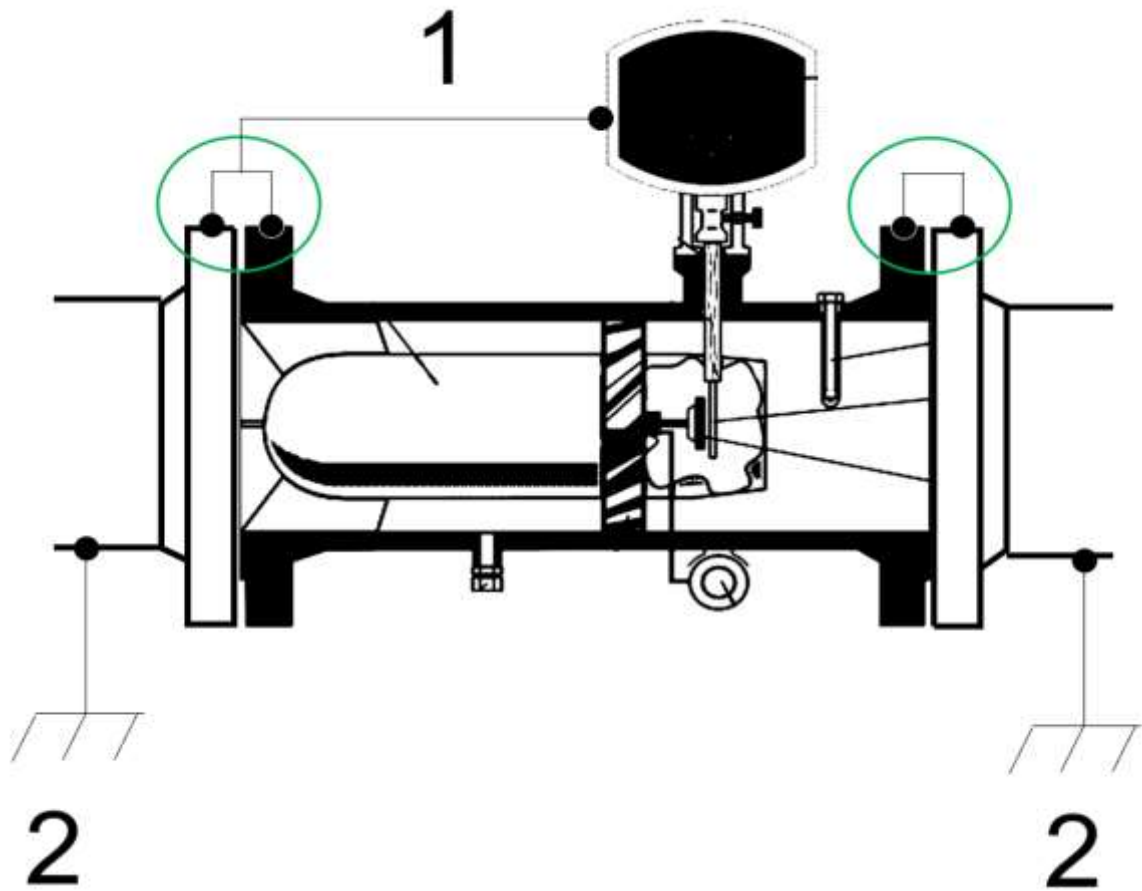

Figure 17: Grounding with the connecting pipes

- 1 Equipotential bonding conductor (PE) min. 6 mm²
- 2 Measuring system potential

5.2 Overview of materials in use

Name	Material
Housing	Cast iron, cast steel, stainless steel, aluminum or welded steel
Flow straightener	Delrin, aluminum or steel
Turbine wheel	Delrin or aluminum
Measuring unit	Aluminum
Ball bearings	Stainless steel
Shafts	Stainless steel
Gear wheels	Stainless steel or plastic
Magnetic coupling	Stainless steel
Meter head	Plastic
Meter printed circuit board	Aluminum, zinc die-casting or brass

6 Error messages

Error messages are shown in the display as an error number and "unit" "Err".



Figure 18: Error message in the display

The message types are:

- E = Error
- W = Warning
- H = Hint

There are the following error messages:

Message type	Error no.	Brief description	Comment
E	1	EEprom version error	Contact RMG service.
E	2	EEprom error	Contact RMG service.
E	3	Pt1000 hardware error	Contact RMG service.

E	4	Temperature min/max error	Check the alarm setting for the temperature.
E	5	Pressure sensor hardware error	Contact RMG service.
E	6	Pressure min/max error	Check the alarm setting for the pressure.
E	7	Gas equation calculation error	Check the alarm setting for the gas equation. Check the parameter entries for the correct unit and reference to the standard conditions.
E	8	Flow rate min/max error	Check the alarm setting for the flow rate.
E	9	X:Y pulse comparison error	Check the alarm setting for the pulse comparison.
E	10	Max. output pulse error	Check the alarm setting for the max. output pulse.
E	11	Current output error	Check your power connections. Contact RMG service in case of uncertainty.
E	12	Error CRC Calibration Parameter	Contact RMG service.
W	101	Warning Battery Capacity low	Please change the battery
H	201	New software version	You have a new firmware version
H	202	Metrology switch open	Metrology switch open
H	203	Code word set	Code word is set

Appendix

A Modbus

The TME400 has a passive RS-485 interface, which means the interface must be supplied with power externally.

98

Parameterizing the Modbus

Modbus activation

H03 RS-485 protocol

0	Off
1	Modbus RTU (default)
2	Modbus ASCII

The **Modbus - ID** is adjusted via the coordinate H04 (default is 1)

The **Modbus - Register - Offset** (MRO) is entered via coordinate H05 (default is 1). The MRO applies for read and write operations.

Baud rate

H01 Baud rate RS-485 interface

0	2400 Bps
1	9600 Bps
2	19200 Bps
3	38400 Bps (default)

Interface parameters

The interface parameters can be adjusted in coordinate H02.

H02 RS-485 interface parameters

0	8N1 (default)
1	8E1
2	8O1
3	7N1
4	7E1
5	7O1

The TME400 recognizes the following Modbus commands:

- (03 Hex) Read Holding Registers
- (06 Hex) Preset Single Register
- (10 Hex) Preset Multiple Regs
- (08 Hex) Subfunction 00 Hex: Return Query data

TME400 Exception Codes

- 01 Illegal Function
- 02 Illegal Data Address (register not available)
- 03 Illegal Data Value (register not writable or incorrect value)

 99

Example (Modbus query/response):

Query:	Send character	
Start Char	:	
Slave Address	01	
Function	03	
Starting Address Hi	07	
Starting Address Lo	CF	2000-1
No. of Points Hi	00	
No. of Points Lo	02	
LRC	24	
carriage return	cr	
line feed	lf	

Response:	Receive character	
Start Char	:	
Slave Address	01	
Function	03	
Byte Count	04	
Data Hi (Reg 2000)	3F	see below
Data Lo (Reg 2000)	80	see below
Data Hi (Reg 2001)	00	see below
Data Lo (Reg 2001)	00	see below
LRC	39	
carriage return	cr	
line feed	lf	

Example (Modbus number formats)

Data type	Register	Value	Byte 1	Byte 2	Byte 3	Byte 4	Byte 5	Byte 6	Byte 7	Byte 8	Byte 9	Byte 10
float	2	1.0	0x3f	0x80	0x00	0x00						
Text	5	"90111200"	0x39	0x30	0x31	0x31	0x31	0x32	0x30	0x30	0x00	0x00
int	1	1357	0x05	0x4d								
long	2	698614	0x00	0x0a	0xa8	0xf6						

Refer to the Modbus specifications for further information.

Characteristics of the TME400 Modbus

- Data types (float, text ...) can only be read or written completely

menu16	:	1 Register
int16	:	1 Register
uint16	:	1 Register
int32	:	2 Register
uint32	:	2 Register
float	:	2 Register
string8	:	4 Register
string12	:	6 Register

- A maximum of 125 registers can be read or written (in one command).

- Text fields must have at least one terminating zero (0x00).

- Writing of certain parameters causes internal initialization of the hardware and/or:

- Deletion of intermediate results (pulse output, meter calculation, etc.).
- Therefore, the parameters should only be overwritten as necessary (e.g. meter factor)
- Meter statuses are delivered as a uint32 value (without decimal)

Modbus - Register (Version:0.001; Matrix: 001; June 2018)

MB reg	Reg. number	Data type	MB access	Coordinate	Name	Access	Unit	Description
300	2	uint32	RW	A01	Volume Base	E	&VolumeUnit	Volume at base conditions
302	2	uint32	RW	A02	Volume Measurement	E	&VolumeUnit	Volume at measurement conditions
304	2	uint32	RW	A03	Volume Base Error	E	&VolumeUnit	Volume at base conditions error
306	2	uint32	RW	A04	Volume Measurement Error	E	&VolumeUnit	Volume at measurement conditions error
308	2	uint32	RW	A05	Volume Measurement Uncor.	E	&VolumeUnit	Volume at measurement conditions uncor.
310	2	uint32	RW	A06	Volume Start/Stop	N	&VolumeUnit	Volume Start/Stop
312	2	uint32	RW	A07	Volume Reset	N	&VolumeUnit	Volume Reset
314	2	uint32	RW	G06	Metering Point	E	---	Name of metering point
MB reg	Reg. number	Data type	MB access	Coordinate	Name	Access	Unit	Description
318	2	float	R	B01	Flow Rate Base	A	&FlowUnit	Flow rate at base conditions
320	2	float	R	B02	Flow Rate Measurement	A	&FlowUnit	Flow rate measurement
322	2	float	R	B03	Frequency	A	Hz	Frequency
324	2	float	R	D01	Temperature	A	°C	Temperature
326	2	float	R	C01	Pressure	A	bar	Current pressure value
328	2	float	R	E01	Conversion factor	A	Zu	Conversion factor
330	2	float	R	F01	Current	A	mA	Current to be output
332	1	uint16	R	Z10	Error Register 1	A	Hex	Error register 1
333	1	uint16	R	Z11	Error Register 2	A	Hex	Error register 2
334	1	uint16	R	Z12	Status Register 1	A	Hex	Status register 1
335	1	uint16	R	Z13	Status Register 2	A	Hex	Status register 2
MB reg	Reg. number	Data type	MB access	Coordinate	Name	Access	Unit	Description
500	6	string12	RW	A10	Meter Factor	E	&CounterFactorUnit	Meter factor
506	2	float	RW	A11	Output Pulse Factor	E	&CounterFactorUnit	Output pulse factor
508	2	float	R	A12	Meter Factor corrected	A	&CounterFactorUnit	Meter factor corrected
510	1	menu16	RW	A20	Display Factor	E		Display factor

511	1	menu16	RW	A21	Digital Output 2 Mode	E		Digital output 2 mode
512	1	menu16	RW	A22	Digital Output 2 Pulse Width	N	ms	Digital output 2 pulse width

102

MB reg	Reg. number	Data type	MB access	Coordinate	Name	Access	Unit	Description
521	2	float	RW	B05	Flow Rate min.	E	&FlowUnit	Flow rate minimum
523	2	float	RW	B06	Flow Rate max.	E	&FlowUnit	Flow rate maximum

MB reg	Reg. number	Data type	MB access	Coordinate	Name	Access	Unit	Description
527	2	float	RW	B08	QmUg	E	&FlowUnit	
529	1	uint16	RW	B09	QmMinTime	E	s	
530	2	float	RW	B10	Coefficient A-2	E	Am2	Error curve linearization coefficient A-2
532	2	float	RW	B11	Coefficient A-1	E	Am1	Error curve linearization coefficient A-1
534	2	float	RW	B12	Coefficient A0	E	A0	Error curve linearization coefficient A0
536	2	float	RW	B13	Coefficient A1	E	A1	Error curve linearization coefficient A1
538	2	float	RW	B14	Coefficient A2	E	A2	Error curve linearization coefficient A2
540	2	float	RW	B15	KKMaxProz	E	kkp	

MB reg	Reg. number	Data type	MB access	Coordinate	Name	Access	Unit	Description
555	1	menu16	RW	C02	Pressure Mode	E		Source for pressure measurement
556	2	float	RW	C03	Pressure Default	E	bar	Default value for pressure
558	2	float	RW	C04	Pressure Minimum	E	bar	Lowest valid pressure
560	2	float	RW	C05	Pressure Maximum	E	bar	Highest valid pressure
562	2	float	RW	C08	Pressure Offset	E		Pressure offset
564	2	float	RW	C09	Pressure Slope	E		Pressure slope
566	2	float	R	C10	Temp. pressure sensor	E	°C	Temperature pressure sensor
568	2	float	R	C11	Temp. pressure sensor min.	E	°C	Temperature range pressure sensor min.
570	2	float	R	C12	Temp. pressure sensor max.	E	°C	Temperature range pressure sensor max.

MB reg	Reg. number	Data type	MB access	Coordinate	Name	Access	Unit	Description
--------	-------------	-----------	-----------	------------	------	--------	------	-------------

587	1	menu16	RW	D02	Temperature Mode	E		Source for temperature measurement
588	2	float	RW	D03	Temperature Default	E	T-V	Default value for temperature
590	2	float	RW	D04	Temperature min	E	°C	Lowest valid temperature
592	2	float	RW	D05	Temperature max	E	°C	Highest valid temperature
594	2	float	RW	D06	Temperature Damping	E	T-D	Damping temperature

103

MB reg	Reg. number	Data type	MB access	Coordinate	Name	Access	Unit	Description
602	2	float	R	D11	Resistance PT1000	A	Ohm	Resistance of PT1000 (corrected)
604	2	float	R	D12	Resistance PT1000 uncor.	A	Ohm	Resistance of PT1000 (uncorrected)
606	2	float	R	D30	Temperature (uncor.)	A	°C	Temperature (uncorrected)

MB reg	Reg. number	Data type	MB access	Coordinate	Name	Access	Unit	Description
616	2	float	RW	D35	Temperature target value 1	N	°C	Temperature target value 1
618	2	float	RW	D36	Temperature target value 2	N	°C	Temperature target value 2
620	2	float	RW	D37	Temperature target value 2	N	°C	Temperature target value 2
622	2	float	RW	D38	Temperature target value 2	N	°C	Temperature target value 2

MB reg	Reg. number	Data type	MB access	Coordinate	Name	Access	Unit	Description
628	1	menu16	RW	D41	Temperature Corr. Write	E		Write temp. correction factors f0/1

MB reg	Reg. number	Data type	MB access	Coordinate	Name	Access	Unit	Description
633	2	float	R	E02	Compression factor	A	K	Compression factor (from AGA8, etc.)

MB reg	Reg. number	Data type	MB access	Coordinate	Name	Access	Unit	Description
639	1	menu16	RW	E05	Calculation Method	E		Calculation method for compress.
640	2	float	RW	E06	Default Compression factor	E	K-V	Default value for the compression factor
642	2	float	RW	E07	Calorific Value	E	Hon	Calorific value
644	2	float	RW	E08	Standard Density	E	rhn	Standard density

646	2	float	RW	E09	Relative Density	E	dv	Relative density
648	2	float	RW	E10	Percentage carbon dioxide	E	CO2	mole fraction of carbon dioxide
650	2	float	RW	E11	Nitrogen	E	N2	mole fraction of Nitrogen
652	2	float	RW	E12	Hydrogen	E	H2	mole fraction of Hydrogen
654	1	menu16	RW	E20	Selection Base Pressure	E		Selection of base pressure
655	1	menu16	RW	E21	Selection Base Temperature	E		Selection of base temperature
656	1	menu16	RW	E22	Selection Base Temp. Cal. Fac.	E		Selection of base temp. calorific value
657	1	menu16	RW	F02	Current Mode	N		Mode current output
658	1	menu16	RW	F03	Current Source	N		Source current output
659	2	float	RW	F04	Physical minimum value	N		Current output phys. minimum value
661	2	float	RW	F05	Physical maximum value	N		Current output phys. maximum value
663	2	float	RW	F06	Current default	N	mA	Current output default
665	2	float	RW	F07	Current Damping	N	I-D	Damping current output
667	2	float	RW	F10	Calibration Value 4mA	N	mA	Calibration: Actual value 4mA
669	2	float	RW	F11	Calibration Value 20mA	N	mA	Calibration: Actual value 20mA
671	4	string8	RW	F12	Module Serial Number	N	SN	Current output module serial no.
675	1	uint16	R	G01	Current Error	A	ERR	Current activated error codes
676	2	float	R	G02	Software Version	A	Rev	Software version
MB reg	Reg. number	Data type	MB access	Coordinate	Name	Access	Unit	Description
680	2	int32	RW	G04	Serial number	E	SNr	Serial number
682	1	uint16	R	G05	Firmware Checksum	A	CRC	Firmware checksum
683	2	float	R	G10	Pressure Base	A	bar	Pressure at base condition
685	2	float	R	G11	Pressure Range min	A	bar	Pressure range minimum
687	2	float	R	G12	Pressure Range max	A	bar	Pressure range maximum
689	6	string12	R	G13	Pressure Sensor Serial Number	A	---	Serial number pressure sensor
695	2	float	R	G14	Temperature Base	A	TN	Temperature at base condition
697	2	int32	RW	G17	Temp. Sensor Serial Number	E	TNr	Serial number temperature sensor

699	2	int32	RW	G18	Serial Number Gas Meter	E	ZNr	Serial number gas meter
701	4	string8	RW	G19	Meter size	E	G	Meter size
705	3	string8	RW	G20	Date of Battery Exchange	C	Bat	Date of battery exchange
790	1	uint16	R	G24	Remaining Battery Capacity	A	%	Remaining Battery Capacity
791	1	menu16	RW	G25	Battery Change	C	-	Battery Change
792	2	uint16	R	G26	Operating Hours	A	h	Operating Hours
MB reg	Reg. number	Data type	MB access	Coordinate	Name	Access	Unit	Description
709	1	menu16	RW	H01	RS485 Baudrate	N	Bps	RS485 interface baudrate
710	1	menu16	RW	H02	RS485 Parameter	N		RS485 interface parameter
711	1	menu16	RW	H03	RS485 Protocol	N		RS485 selection of protocol
712	1	uint16	RW	H04	Modbus ID	N	MID	Modbus ID
713	1	uint16	RW	H05	Modbus Register Offset	N	Mof	Modbus register offset
714	3	string8	RW	X01	Time	E	T	Time
717	3	string8	RW	X02	Date	E	D	Date
MB reg	Reg. number	Data type	MB access	Coordinate	Name	Access	Unit	Description
722	1	menu16	RW	X10	Delete Parameter Archive	E		Delete parameter archive
723	1	uint16	R	X11	Fill level Para. Archive	A	%	Fill level parameter archive
724	1	menu16	RW	X12	Delete Parameter Archive(E)	E		Delete parameter archive (E)
725	1	uint16	R	X13	Fill level Para. Archive (E)	A	%	Fill level parameter archive (E)
726	1	menu16	RW	X14	Delete Event Archive	E		Delete event archive
727	1	uint16	R	X15	Fill level Event Archive	A	%	Fill level event archive
728	1	menu16	RW	X16	Mode archives	E		Mode Archives
729	1	menu16	RW	X17	Interval Minute Archive	E		Interval minute archiv
730	1	menu16	RW	X18	Delete Minute Archive	E		Delete minute archive
731	1	uint16	R	X19	Fill level Minute Archive	A	%	Fill level minute archive
732	1	menu16	RW	X20	Delete Day Archive	E		Delete day archive
733	1	uint16	R	X21	Fill level Day Archive	A	%	Fill level day archive
734	1	menu16	RW	X22	Delete Month archive	E		Delete month archive
735	1	uint16	R	X23	Fill level Month Archive	A	%	Fill level month archive
812	1	menu16	W	X24	Delete all archives	E	-	Deleting of all archives

106

MB reg	Reg. number	Data type	MB access	Coordinate	Name	Access	Unit	Description
775	1	uint16	RW	Z04	X:Y maximum Pulse Errors	E	X	Pulse compare X:Y maximum pulse errors
776	1	uint16	RW	Z05	X:Y maximum Pulses	E	Y	Pulse compare X:Y maximum pulses
777	1	uint16	RW	Z15	Code Word Input	N	COD	Code word input
778	1	uint16	RW	Z16	Code Word Change	C	C-V	Code word change
779	1	menu16	RW	Z17	Device Type	E		Device type
780	1	menu16	RW	Z24	Display on max.	N		Maximum time display on
781	1	menu16	RW	Z25	Volume Count Mode	E		Selection mode of volume counter
782	1	menu16	RW	Z26	Curve Linearization	E		Selection curve linearization
783	1	menu16	RW	Z27	Sensor Type 1	E		Selection turbine sensor channel 1
784	1	menu16	RW	Z28	Sensor Type 2	E		Selection turbine sensor channel 2
785	1	menu16	RW	Z29	Unit Volume	E		Selection volume unit
819	1	uint16	R	Z42	Warning Register 1	A	Hex	Warning register 1
820	1	uint16	R	Z43	Warning Register 2	A	Hex	Warning register 2
821	1	uint16	R	Z44	Hint Register 1	A	Hex	Hint register 1
822	1	uint16	R	Z45	Hint Register 2	A	Hex	Hint register 2

The Modbus access has the meaning:

R = no protection
 RW = calibration button

Error, warning, hint and status registers

MB reg	Reg. number	Data type	MB access	Bit	Description	Event number
332	1	uint16	R	0	-	-
				1	Error: Power-Fail	1
				2	Error: EEprom	2
				3	Error: Pt1000-Hardware	3
				4	Error: Temperature min/max	4
				5	Error: Pressure Sensor-Hardware	5
				6	Error: Pressure min/max	6
				7	Error: Calculation Gas Equations	7
				8	Error: Flow min/max	8
				9	Error: Pulse Comparison X:Y	9
				10	Error: max. Output Pulses	10
				11	Error: Current Output	11
				12	Error: CRC Calibration Parameter	12
			13 ... 15	-	-	
333	1	uint16	R		Not assigned	-
334	1	uint16	R	0	-	-
				1	Status: Code Word enabled	
				2	Status: Calibration switch open	
				3	Status: External Power Supply RS485 on	
				4	Status: Current Loop on	
				5	Status: Pulse Input 1 closed	
				6	Status: Pulse Input 2 closed	
				7	Status: Digital Input 1 closed	
				8	Status: Battery Capacity < 10%	
			9 ... 15	-	-	
335	1	uint16	R		Not assigned	-
819	1	uint16	R	0	-	-
				1	Warning: Battery Capacity < 10%	101
				2 ... 15	-	-
820	1	uint16	R		Not assigned	-
821	1	uint16	R	0 ... 1	-	-
				2	Hint: Calibration Switch open	202
				3	Hint: Code Word enabled	203
				4 ... 15	-	-
822	1	uint16	R		Not assigned	-

B Structure of the archives

In this appendix you will find more information about the archives:

- Archive size
- Archive types
 - Parameter archives
 - Event archives
 - Measured values archives
- Calculation of the storage size
- Archive header
- Reading the archive data via Modbus

108

B1 Archive size

The TME400 has an archive storage divided into the following archive types with the given archive sizes:

Event archive	200 Entries
Parameter archive (custody transfer)	300 Entries
Parameter archive (non-custody transfer)	300 Entries
Month archive	25 Entries
Day archive	100 Entries
Periodic archive	9000 Entries

B2 Archive types

Below is a list of further data on the parameter, event and measured value archives.

B2.1 Parameter archives

The parameter archive contains the history of all parameter changes. The time of the change and the old and the new parameter values are stored in the archive.

The parameter archives are divided into one archive each for custody transfer and non-custody transfer parameters.

Internal structure of an entry:

Content	Data type	Length in Bytes
Position number	UINT16	2
Unix time (device time)	UINT32	4
Coordinate	UINT16	2
Old parameter value	CHAR	12
New parameter value	CHAR	12
CRC16 (Modbus)	UINT16	2
		Total length: 34

Coordinate:

- High byte: column („A“-„Z“ as ASCII)
- Low byte: line

A value in the coordinate field 4103h corresponds to coordinate A 03.

B2.2 Event archives

The event archive stores error messages, warnings and notes that occurred or disappeared during operation of the TME400.

Internal structure of an entry:

Content	Data type	Length in Bytes
Position number	UINT16	2
Unix time (device time)	UINT32	4
Event type	UINT16	2
Event number	UINT16	2
CRC16 (Modbus)	UINT16	2
		Total length: 12

Event type:

- High byte: type ('E' = error, 'W' = warning, 'H' = note)
- Low byte: 0 = Event passes, 1 = Event is coming

110

B2.3 Measured values archives

In the measured value archives, meter readings and average values of important measured variables are periodically stored.

There are three types of measured value archives implemented:

- Periodic archive (adjustable: 15, 30 or 60 minutes)
- Daily archive
- Monthly archive

Internal structure of an entry:

Content	Data type	Length in Bytes
Position number	UINT16	2
Unix time (device time)	UINT32	4
Standard volume	UINT32	4
Operating volume	UINT32	4
Standard volume Error	UINT32	4
Operating volume Error	UINT32	4
Exponent (to base 10)	INT16	2
Mean pressure	FLOAT	4
Mean temperature	FLOAT	4
Mean compressibility	FLOAT	4
Status	UINT16	2
CRC16 (Modbus)	UINT16	2
		Total length: 40

B3 Calculation of the storage size

The total available storage for archives is 506880 bytes.

Archive type	Bytes / entry	Amount entries	Sum in bytes
Parameter archive (custody transfer)	34	300	10200
Parameter archive (non-custody transfer)	34	300	10200
Event archive	12	200	2400
Periodic archive	40	9000	360000
Daily archive	40	100	4000
Monthly archive	40	25	1000
Sum			387800

111

B4 Archive header

Each archive type contains an administration header that gives information about how to access the archive.

The header is arranged as follows:

Content	Data type	Length in Bytes
Position number of the next archive (largest value = 9999, then again = 0)	UINT16	2
Index oldest entry	UINT16	2
Index newest entry	UINT16	2
CRC16 (Modbus)	UINT16	2
		Total length: 8

There are four headers for each archive type, which are organized in memory as ring buffers. This is to ensure that the information is stored safely in case of cell defects in the EEPROM. Each time a new archive entry is written, the corresponding archive header is updated and stored as the next entry in the ring buffer:

Empty header ring buffer at the beginning after writing a new entry:

Storage index	
0	Archive header (Position number 1) -> Actual header
1	empty
2	empty
3	empty

112

Ring buffer after the writing of four entries:

Storage index	
0	Archive header (Position number 1)
1	Archive header (Position number 2)
2	Archive header (Position number 3)
3	Archive header (Position number 4) -> Actual header

Ring buffer after the writing of six entries:

Index	
0	Archive header (Position number 5)
1	Archive header (Position number 6) -> Actual header
2	Archive header (Position number 3)
3	Archive header (Position number 4)

Content of an empty header:

Content	Data type	Value
Position number of the next archive	UINT16	0
Index of the oldest entry	UINT16	FFFFh
Index of the newest entry	UINT16	FFFFh
CRC16	UINT16	xxxxh

Content of the header after the writing of the first archive entry:

Inhalt	Data type	Value
Position number of the next archive	UINT16	1
Index of the oldest entry	UINT16	0
Index of the newest entry	UINT16	0
CRC16	UINT16	xxxxh

Content of the header after the writing of the second archive entry:

Content	Data type	Value
Position number of the next archive	UINT16	2
Index of the oldest entry	UINT16	0
Index of the newest entry	UINT16	1
CRC16	UINT16	xxxxh

Content header after the writing of the 300th archive entry (archive full):

Content	Data type	Value
Position number of the next archive	UINT16	300
Index of the oldest entry	UINT16	0
Index of the newest entry	UINT16	299
CRC16	UINT16	xxxxh

Content header after the writing of the 301st archive entry (archive full, oldest entry overwritten in the ring buffer):

Content	Data type	Value
Position number of the next archive	UINT16	301
Index of the oldest entry	UINT16	1
Index of the newest entry	UINT16	0
CRC16	UINT16	xxxxh

Procedure for determining the indexes to be read in the archive:

- Reading all four archive headers of an archive type
- Recognizing the current header
- Determine the range to be read:
 If "Index oldest entry" = FFFFh and "Index newest entry" = FFFFh, then the corresponding archive is empty

 If "Index oldest entry" = 0 and "Index newest entry" = 0, then the archive contains an entry
- If "Index oldest entry" < "Index newest entry", then the
 Number of entries = "Index newest entry" - "Index oldest entry" + 1
- If "Index oldest entry" > "Index newest entry", then the
 No. of ent. = max. archive ent. - "Index older ent." + "Index newest ent." + 1
 (Archive is always full: Number of entries = Maximum archive entries, Calculation for the purpose of completeness only)

B5 Reading the archive data via Modbus

Archive entries are accessible via Modbus. The command 14h "Read General Reference" is used for this. This command can be used to index the storage ranges of the archives and the corresponding management headers (see document: "Modicon Modbus Protocol; Reference Guide (PI-MBUS-300 Rev. J)")

The TME400 only supports the processing of a sub-request within one request.

The structure of the request string is as follows:

Byte	Meaning
1	Device address
2	Function (14h)
3	Number of bytes (07h)
4	Reference type (00h)
5	File number (Hi)
6	File number (Lo)
7	Start index (Hi)
8	Start index (Lo)
9	Number of registers to be read (Hi)
10	Number of registers to be read (Lo)
11	CRC (Lo)
12	CRC (Hi)

The specified reference type in the request string is not checked in the TME400.

The following file number selects the archive or archive header to be read:

File number	Archive type
1	Management header custody transfer parameter archive
2	Custody transfer parameter archive
3	Management header parameter archive
4	Parameter archive
5	Management header event archive
6	Event archive
7	Management header minutes archive
8	Minutes archive
9	Management header daily archive
10	Daily archive
11	Management header monthly archive
12	Monthly archive

With the file address the index of the archive to be read is selected.

The number of registers of the bytes which are read from an archive entry (number of bytes = number of registers x 2). The maximum number of registers to be read is limited to 125 per request.

The following example shows the data to be read in a request:

- File number: 6 (Event archive, size: 12 Byte per entry)
- Start index: 7 (Read from index 7)
- Number of registers: 13

Archive index	Modbus register	Internal storage address of the TME400
7	1 (Hi)	0 (+ Offset)
	1 (Lo)	1 (+ Offset)
	2 (Hi)	2 (+ Offset)
	2 (Lo)	3 (+ Offset)

	6 (Hi)	10 (+ Offset)
8	6 (Lo)	11 (+ Offset)
	7 (Hi)	12 (+ Offset)
	7 (Lo)	13 (+ Offset)
	8 (Hi)	14 (+ Offset)
	8 (Lo)	15 (+ Offset)

9	12 (Hi)	22 (+ Offset)
	12 (Lo)	23 (+ Offset)
	13 (Hi)	24 (+ Offset)
	13 (Lo)	24 (+ Offset)

The example shows the reading of two complete event archive entries (index 7 and 8) and a part archive (2 bytes from index 9). In practice, it makes sense to request only complete archives. The above case is used exclusively to illustrate the mechanism.

C Dimensions

TME400-VC

116

Front view

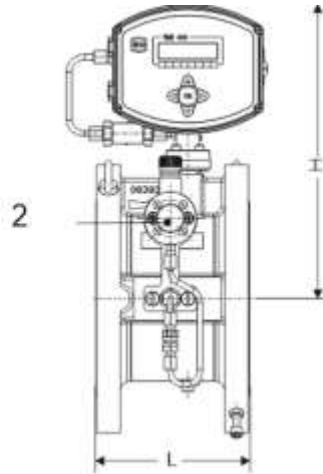

Rear side

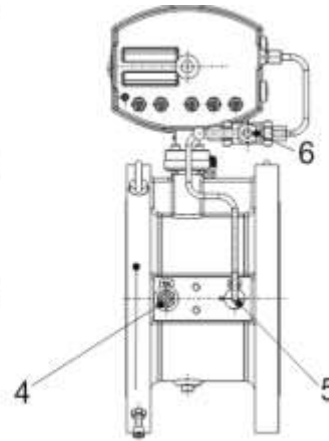

7

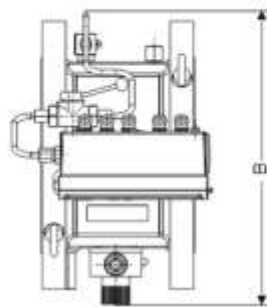

8

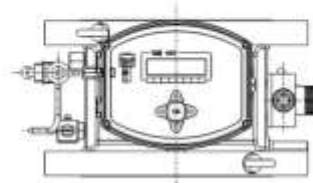

- 1 -
- 2 Oil pump
- 3 -
- 4 Temperature connection

- 5 Pressure connection
- 6 Ball valve
- 7 Top view
- 8 Top view for flow direction from bottom top up to DN200

Size		Max. Flow rate Qmax m3/h	Dimensions			Weigth kg
mm	Inch		Length L	Width B	Hight H	
50	2	65	150	235	262	15
80	3	160	120	265	290	18
		250				
		400				
100	4	250	150	285	310	24
		400				
		650				
150	6	650	175	325	330	40
		1000				
		1600				
200	8	1600	200	400	365	55
		2500				
250	10	1600	300	450	400	ANSI150 = 65 PN10 = 60 PN25 = 71
		2500				
		4000				
300	12	4000	300	560	410	ANSI150 = 100 PN10 = 90 PN25 = 105
		6500				
		6500**				
400	16	6500	600	640	416	PN16 = 186 PN40 = 275
		10000				

TME400-VCF

Front view

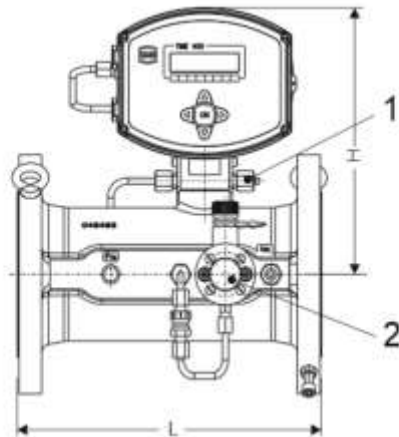

Rear side

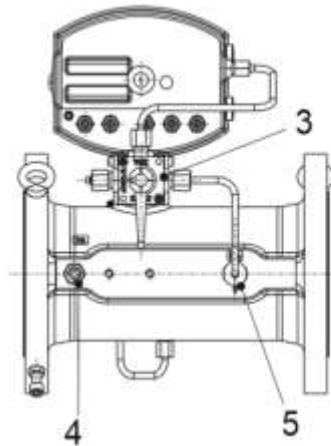

7

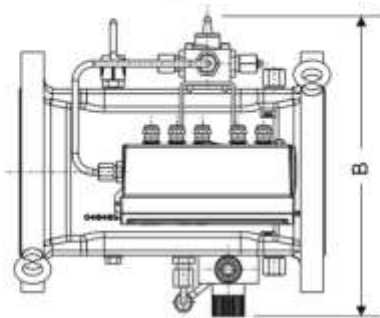

8

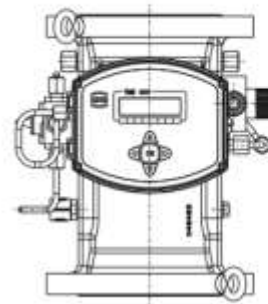

- 1 Pressure test connection
- 2 Oil pump
- 3 Three-way test valve
- 4 Temperature connection

- 5 Pressure connection
- 6
- 7 Top view
- 8 Top view for flow direction from bottom top up to DN200

Size		G-Size	Max. Flow rate Qmax m ³ /h	Dimensions			Weigth kg
mm	Inch			Length L	Width B	Hight H	
50	2	G65	65	150	320	310	15
80	3	G100	160	240	270	250	20
		G160	250				
		G250	400				
100	4	G160	250	300	285	254	28
		G250	400				
		G400	650				
150	6	G400	650	450	310	280	50
		G650	1000				
		G1000	1600				
200	8	G1000	1600	600	380	320	100
		G1600	2500				
250	10	G1000	1600	750		345	ANSI150 = 160 PN16 = 150 PN10 = 150
		G1600	2500				
		G2500	4000				
300	12	G2500	4000	900		360	ANSI150 = 250 PN16 = 215 PN10 = 210
		G4000	6500				
		G4000-45	6500**				

Remote meter

120

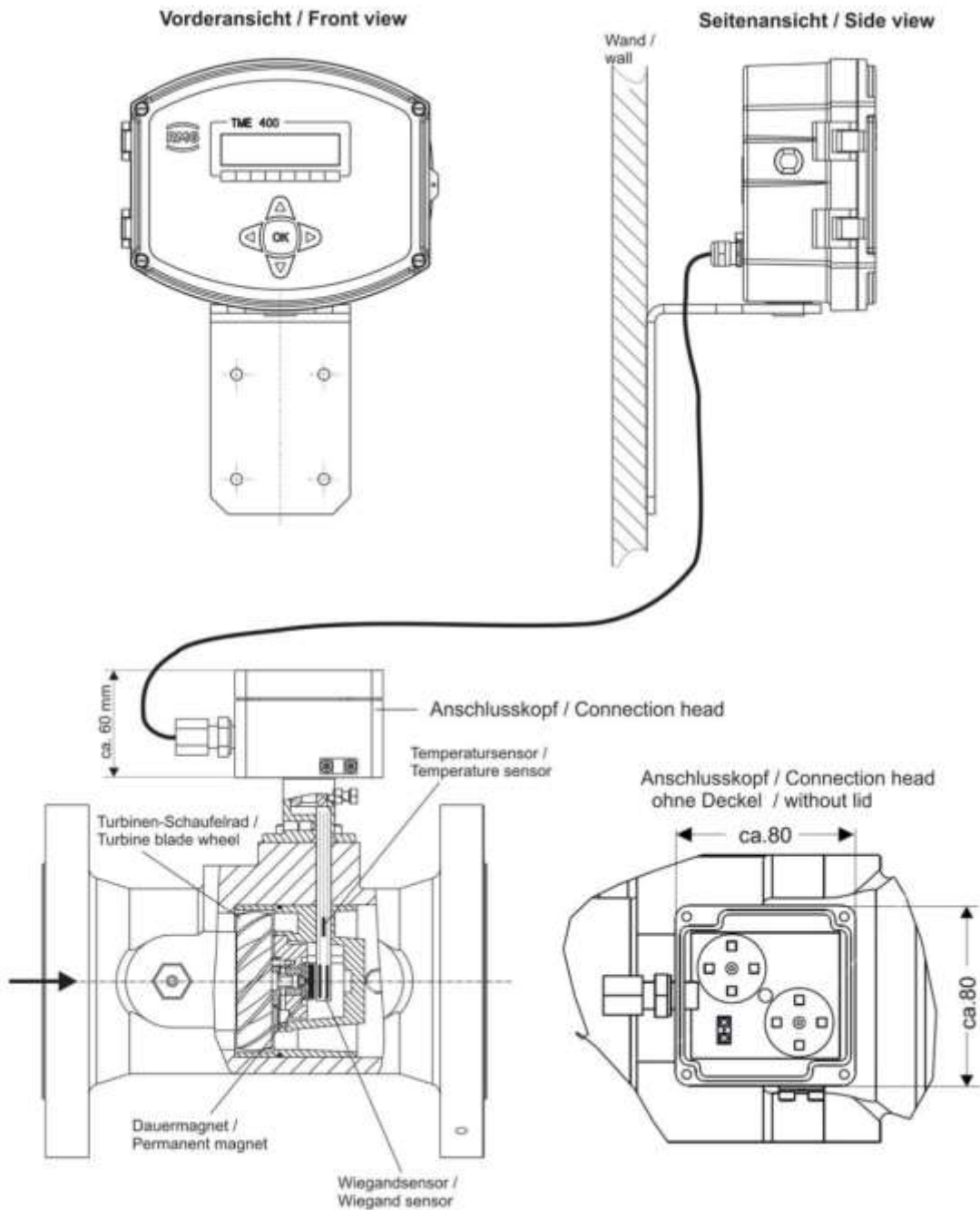

Cable length: 10 m
 Pressure sensor: integrated in the connection head
 Height: approx. 80 mm less than the „normal“ height (see above)

D Measuring ranges for TME 400-VMF/ TME 400-VCF

Values for custody transfer metering according to MID approval with natural gas

DN [mm]	G- value	Q _{max} [m ³ /h]	Flow [m ³ /h] at p _{min} =1 bar ^[1] MR ^[2] 1:20		Q _{min} [m ³ /h] depending on operating pressure p _{min} [bar(g)]											
			Q _t	Q _{min}	MR 1:30		MR 1:50		MR 1:80		MR 1:100		MR 1:120		MR 1:160	
					Q _{min}	p _{min}	Q _{min}	p _{min}	Q _{min}	p _{min}	Q _{min}	p _{min}	Q _{min}	p _{min}	Q _{min}	p _{min}
50	65	100	20	5 ^[3]												
80	100	160	32	8 ^[3]	5	15	3,2	50								
	160	250	50	12,5	8	3	5	10	3,2	50						
	250	400	80	20	13	3	8	10	5	25						
100	160	250	50	12,5	8	3	5	25								
	250	400	80	20	13	3	8	10	5	25						
	400	650	130	32	20	3	13	4	8	10	6,5	15	5	25		
150	400	650	130	32	20	3	13	10	8	25	6,5	40				
	650	1000	200	50	32	3	20	4	13	10	10	15	8	25		
	1000	1600	320	80	50	3	32	4	20	10	16	15	13	25	10	40
200	1000	1600	320	80	50	3	32	4	20	10	16	15	13	25	10	40
	1600	2500	500	125	80	3	50	4	32	10	25	15	20	25	16	40
250	1000	1600	320	80	50	3	32	10	20	25	16	40				
	1600	2500	500	125	80	3	50	4	32	10	25	25	20	40	16	60
	2500	4000	800	200	130	3	80	4	50	10	40	25	35	40	25	60
300	2500	4000	800	200	130	3	80	4	50	10	40	25	35	40	25	60
	4000	6500	1300	320	220	3	130	10	80	25	65	40	55	60	40	80
	4000-45	6500	1300	320	220	3	130	10	80	25	65	40	55	60	40	80

^[1] p = 1 bar; means atmospheric pressure

^[2] MR = Measuring range = Q_{max} / Q_{min}

^[3] MR: 1:20; for p ≥ 3 bar(g)

E Measuring accuracy for TME 400-VC

DN	Q _{min} [m ³ /h] Q _{max} [m ³ /h]		MR	Error of measurement in the range		with error curve linearization ¹⁾ Q _{min} to Q _{max}	MR extension with error curve linearization ¹⁾ and limited measuring accuracy	
	Q _{min} [m ³ /h]	Q _{max} [m ³ /h]		Q _{min} to 0.2 Q _{max}	0.2 Q _{max} to Q _{max}		MB	Q _{min} [m ³ /h] Q _{min} to Q _{max}
25	2,5	25	1:10	±2%			1	
40	6	70	1:12	±1.5%			3	
50	6	100	1:16	±1.5%			4	
80	13	160	1:12	±3%	±1%	±1%	8	1:20
	16	250					8	1:30
	25	400					13	
100	25	400	1:16	±2%	±1%		13	
	40	650					20	
80	13	250	1:20	±3%	±1.5%		8	
	20	400					13	
100	20	400	1:20	±3%	±1.5%		13	
	32	650					20	
150	32	650	1:20	±2%	±1%		20	
	50	1000					30	
200	80	1600	1:20	±2%	±1%		50	
	125	2500					40	
250	125	2500	1:20	±2%	±1%		62.5	
	200	4000					50	
300	200	4000	1:20	±2%	±1%		80	
	325	6500					80	
400	325	6500	1:20	±2%	±1%		130	
	500	10000					130	
500	500	10000	1:20	±2%	±1%		200	
	800	16000					200	
600	800	16000	1:20	±2%	±1%		320	
	1250	25000					320	

DN [mm]	Size	Q _{max} [m ³ /h]	Flow rates at p _{min} =air,atm		Measuring error for pressures < 3 barg		Measuring error for pressures ≥ 3 barg	
			Q _{min} [m ³ /h] MR ^[1] 1:20	Q _t [m ³ /h] MR 1:20	in the range Q _{min} to 0,2Q _{max}	with error curve correction ^[3] Q _{min} to Q _{max}	in the range Q _{min} to 0,2Q _{max}	with error curve correction ^[3] Q _{min} to Q _{max}
50	G 65	100	5 ²⁾	20	±2%	±1%	±1%	±0,5%
80	100	160	8 ²⁾	32	±1%	±1%	±1%	±0,5%
	160	250	12,5	50				
	250	400	20	80				
100	400	650	32	130				
	160	250	12,5	50				
	250	400	20	80				
	400	650	32	130				
150	400	650	32	130				
	650	1000	50	200				
	1000	1600	80	320				
200	1000	1600	80	320				
	1600	2500	125	500				
250	1000	1600	80	320				
	1600	2500	125	500				
	2500	4000	200	800				
300	2500	4000	200	800	±2%	±1%	±1%	±0,5%
	4000	6500	320	1300				
	4000-45	6500	320	1300				
400	4000	6500	320	1300				
	6500	10000	500	2000				
	6500-45	10000	500	2000				
500	6500	10000	500	2000				
	10000	16000	800	3200				
	10000-45	16000	800	3200				
600	10000	16000	800	3200				
	16000	25000	1250	5000				

For TME 400-VCF

[1] MR = Measuring range = Q_{max}/Q_{min}

[2] MR 1:20 for p_{min} ≥ 3 barg

[3] Correction of the error curve must be specified when ordering (extra charge); note the information for operation with correction of the error curve, see man-

F Type plate

Main type plate TME400-VC for DN25, for Non-Ex, no custody transfer applications



124

Main type plate TME400-VC from DN40, for Non-Ex, no custody transfer applications

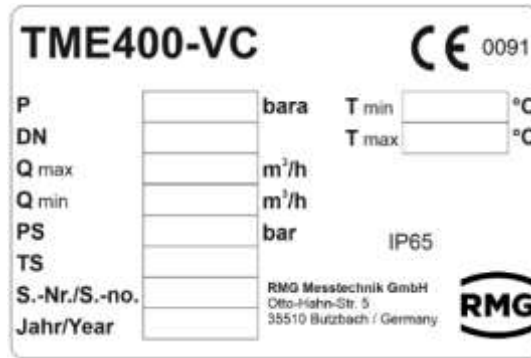

Main type plate TME400-VCF for Non-Ex, custody transfer applications

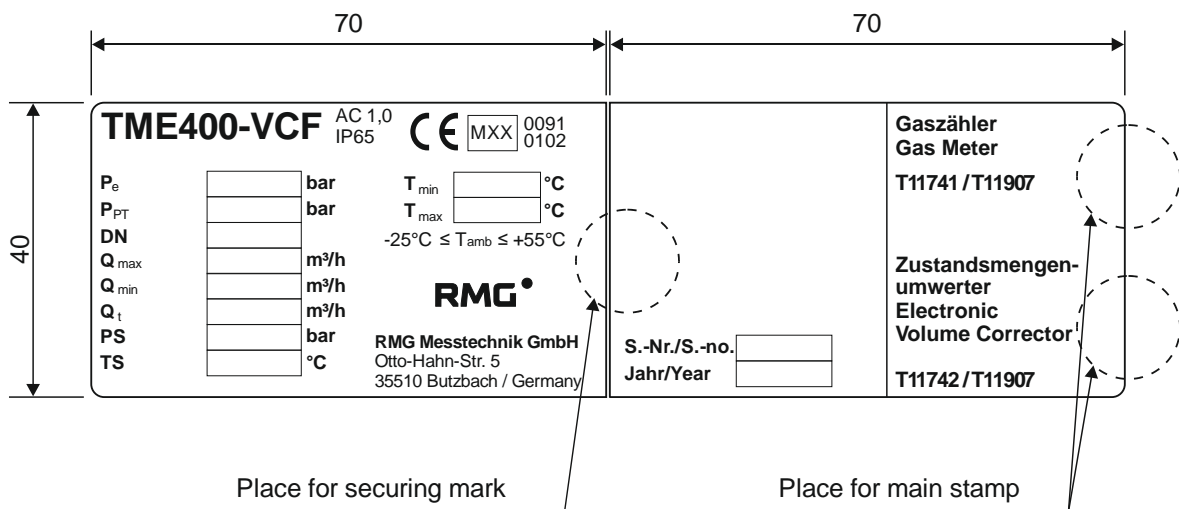

Main type plate TME400-VC for DN25, for Ex, no custody transfer applications

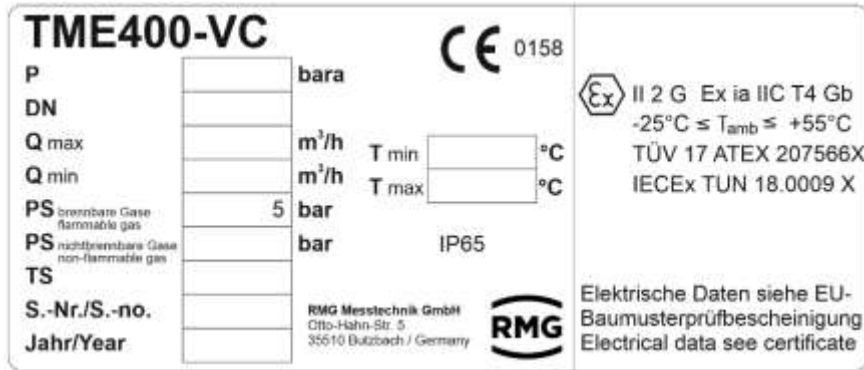

125

Main type plate TME400-VC from DN40, for Ex, no custody transfer applications

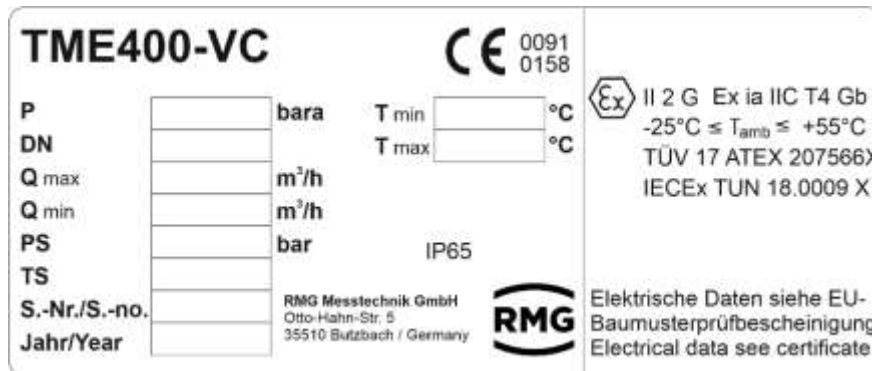

Main type plate TME400-VCF for Ex, custody transfer applications

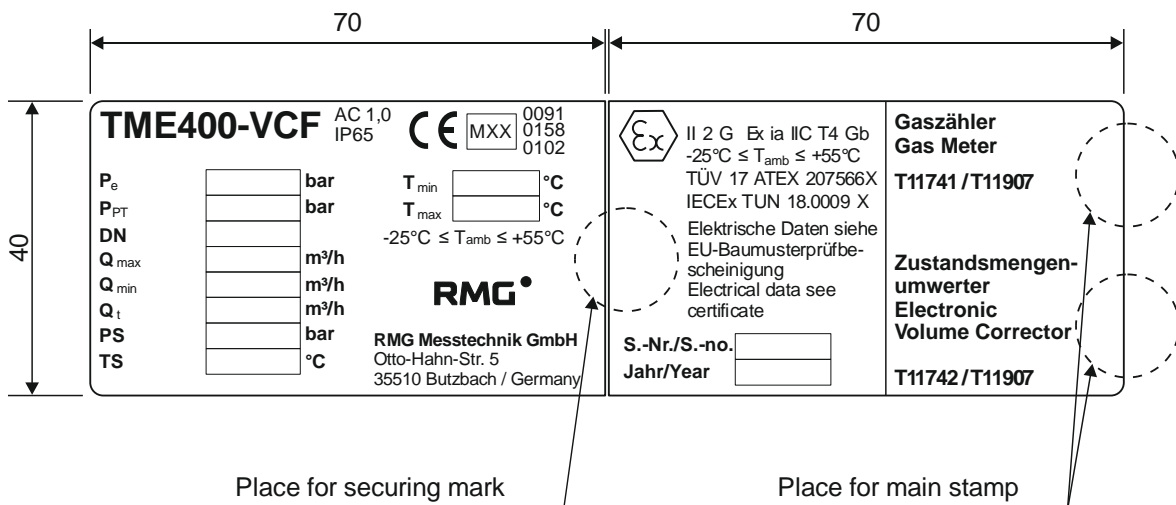

G Seal diagrams

The following figures show the positions of the seals on the TME400.

Front side



Security seal
Sicherheitsplombe

Back side



Seal cap with lead seal
Siegelkappe mit Bleiplombe

In the electronic enclosure



Security seal
Sicherheitsplombe

At the connection head



Sicherheitsplombe
Security seal

H Later installation of the power module

⚠ Caution

The power module must only be installed in a de-energized state.

In order to switch of any power supply the battery must be removed (see *chapter 3.1.4 Battery replacement*) and any external supply voltage must be switched off, i.e. in the case of an external supply, the wires from terminals X6 / +Uext and X6 / -Uext must be removed.

The power module (3) must be plugged on as shown in *Figure 1: Electronic with power module*. The current module is factory adjusted and **does not need** to be calibrated before operation.

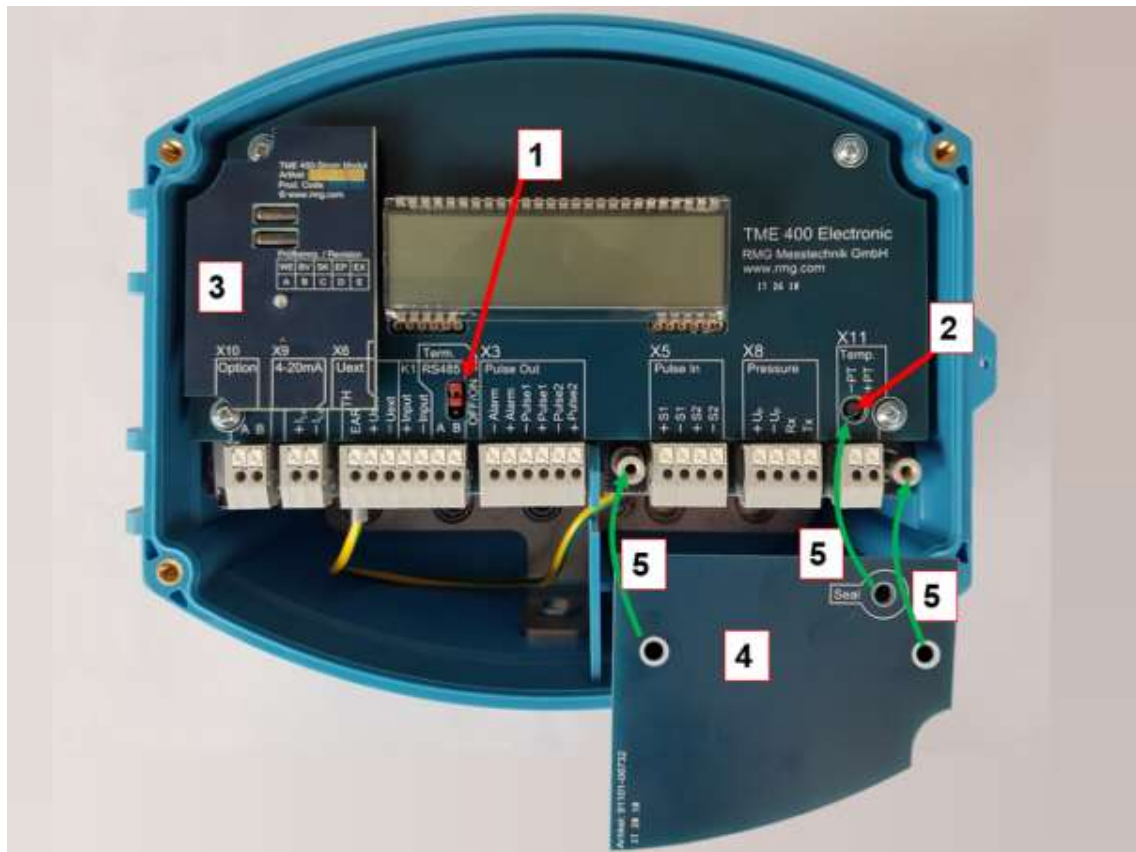

Figure 1: Electronic with power module

- 1 Jumper for RS 485 terminating resistor. Bridged: with 120 Ω; open: ∞ Ω
- 2 Calibration switch
- 3 Current module board
- 4 Cover plate for pressure and temperature sensor and calibration switch
- 5 Normal position, indicated by green arrows

Putting the power module into operation

After reconnecting the TME400 supply voltages, the current loop power supply must be connected to X9 and the current output parameterized.

Caution

The voltages of the current loop and the external supply must be electrically isolated (galvanically isolated see *chapter 2.1 Electrical connections*, especially the connection drawings in the Ex- /Non-Ex area at the end of the chapter).

Parameterization of the current module

To complete the installation, various parameters must be checked or configured. To do this, the parameter protection must be removed, either by entering the code word (see *chapter 4.3.3.10 Settings*) or by pressing the calibration button (see *Figure 1: Electronic with power module*).

1. First the date and time must be entered in the coordinates X1 and X2
2. The current output parameters F02, F03, F04, F05 (see *chapter 4.3.3.6 Current output*) must then be parameterized according to the application.

For example, a typical parameterization may look like this:

F02:	1	Without error
F03:	1	Operating flow rate
F04:	0	i.e. 4 mA = 0 m ³ /h
F05:	200	i.e. 20 mA = 200 m ³ /h

For testing, F03 can be set to 0 (default) and a current value in the range of 4 - 20mA can be selected with F06.

I Spare parts and accessories

Parts of the versions TME 400-VM and TME 400-VC

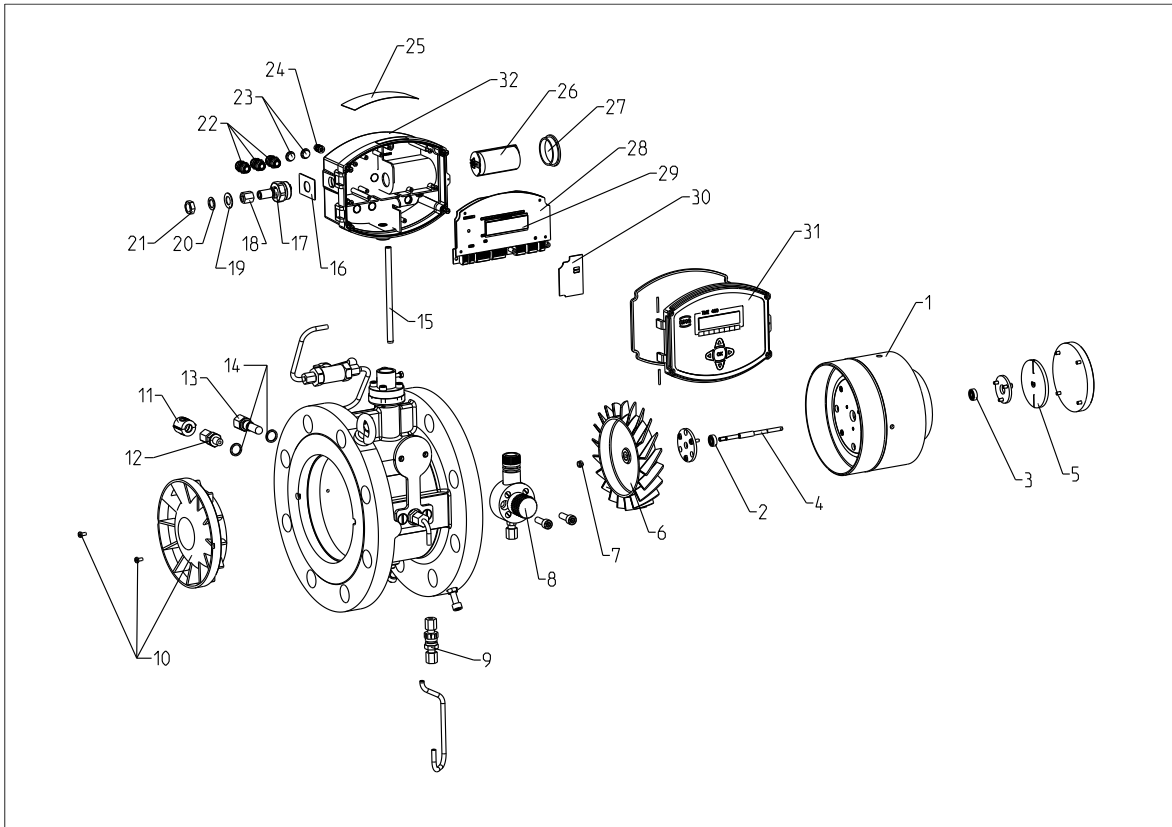

The spare parts marked in red in the following tables are intended exclusively for replacement by RMG service partners!

TME 400-VM/VC (DN 25-DN 100)

Dr.no.	Article description	DN25	DN40	DN50	DN80	DN100
1	Measuring chamber complete with lubrication	-	00.65.957.00	00.65.957.00	00.49.655.00	00.50.253.00
1	Measuring chamber complete without lubrication	00.65.961.00	00.65.959.00	00.65.959.00	00.52.945.00	00.53.409.00
2	front ball bearing	65.19.333.00	65.19.372.00	65.19.372.00	65.19.351.00	65.19.352.00
3	Rear ball bearing	65.19.332.00	30.00.399.00	30.00.399.00	65.19.372.00	65.19.380.00
4	Drive shaft	00.52.416.00	00.50.231.00	00.50.231.00	00.64.257.00	00.50.348.00
5	Disk and magnet (screw and ring included)	integrated in drive shaft dr.-pos. 4	integrated in drive shaft dr.-pos. 4	integrated in drive shaft dr.-pos. 4	integrated in drive shaft dr.-pos. 4	00.64.258.00 1x 66.64.515.00 1x
6	Turbine wheel 45° aluminium	-	00.47.680.00	00.47.680.00	00.46.745.00	00.46.471.00
	Turbine wheel 30° aluminium	-	-	-	00.48.224.00	00.48.046.00
	Turbine wheel 45° plastic	00.52.364.00	00.47.110.00	00.47.110.00	00.46.743.00	00.46.472.00
	Turbine wheel 30° plastic	-	-	-	00.49.528.00	00.49.529.00
	Turbine wheel bushing	-	-	-	00.46.811.00 1x	00.60.235.00 1x
	Screws turbine wheel aluminium	-	-	-	61.22.079.00 2x	61.24.152.00 3x
	Set screw turbine wheel aluminium	-	-	-	62.40.109.00 1x	62.40.109.00 1x
	Set screw turbine wheel plastic	-	-	-	-	64.34.012.00 1x
7	Nut turbine wheel	-	62.66.070.00	62.66.070.00	62.66.070.00	62.66.072.00
8	Lubrication pump	-	90.59.266.00	90.59.266.00	90.59.266.00	90.59.266.00
9	Check valve	84.08.021.00	84.08.021.00	84.08.021.00	84.08.021.00	84.08.021.00
10	Flow straightener with screws	00.52.369.00	00.55.533.00	00.47.170.00 1x 61.34.211.00 2x	00.48.650.00 1x 61.34.211.00 2x	00.47.339.00 1x 61.34.211.00 2x
11	Seal for screw connector	00.60.316.00	00.60.316.00	00.60.316.00	00.60.316.00	00.60.316.00
12	Screw-in connector (standard)	67.00.215.00	67.00.215.00	67.00.215.00	67.00.215.00	67.00.215.00
13	Thermowells	-	-	00.56.533.14	00.55.523.14	00.55.523.14
14	Sealing ring G1/4 Sealing ring G3/8	81.54.614.00	81.54.614.00	81.54.614.00	81.54.614.00	81.54.614.00
15	Sensor VM	01.64.368.00	01.64.368.00	01.64.368.00 or sandwich bodies 01.64.368.01 for ductile cast iron bodies 01.64.368.02 for steel cast bodies	01.64.368.06 for ductile cast iron and steel cast bodies 01.64.368.03 for round material bodies PN10/16 01.64.368.04 for round material bodies A300/600RF	01.64.368.07 for ductile cast iron bodies and steel cast bodies and round material bodies A300RF 01.64.368.05 for round material bodies PN10/16 01.64.368.08 for round material bodies A600RF

15	Sensor VC	01.64.368.30 01.64.368.60 class A	01.64.368.30 01.64.368.60 class A	01.64.368.30 for sandwich bodies 01.64.368.60 class A for sandwich bodies 01.64.368.31 for ductile cast iron bodies 01.64.368.61 class A for ductile cast iron bodies 01.64.368.32 for steel cast bodies 01.64.368.62 class A for steel cast bodies	01.64.368.36 for ductile cast iron and steel cast bodies 01.64.368.66 class A for ductile cast iron and steel cast bodies 01.64.368.33 for round material bodies PN10/16 01.64.368.63 class A for round material bodies PN10/16 01.64.368.34 for round material bodies A300/600RF 01.64.368.64 class A for round material bodies A300/600RF	01.64.368.37 for ductile cast iron and steel cast bodies and round material bodies A300RF 01.64.368.67 class A for ductile cast iron and steel cast bodies and round material bodies A300RF 01.64.368.35 for round material bodies PN10/16 01.64.368.65 class A for round material bodies PN10/16 01.64.368.38 for round material bodies A600RF 01.64.368.68 class A for round material bodies A600RF
16	Locking plate (only VC)	00.67.200.00	00.67.200.00	00.67.200.00	00.67.200.00	00.67.200.00
17	Pressure transmitter (only VC)	98800-17180 0.8-2.5 bar 98800-17190 0.8-6 bar 98800-17200 2-10 bar 98800-17210 4-20 bar 98800-17360 8-40 bar	98800-17180 0.8-2.5 bar 98800-17190 0.8-6 bar 98800-17200 2-10 bar 98800-17210 4-20 bar 98800-17360 8-40 bar	98800-17180 0.8-2.5 bar 98800-17190 0.8-6 bar 98800-17200 2-10 bar 98800-17210 4-20 bar 98800-17360 8-40 bar	98800-17180 0.8-2.5 bar 98800-17190 0.8-6 bar 98800-17200 2-10 bar 98800-17210 4-20 bar 98800-17360 8-40 bar	98800-17180 0.8-2.5 bar 98800-17190 0.8-6 bar 98800-17200 2-10 bar 98800-17210 4-20 bar 98800-17360 8-40 bar
18	Cap nut and compression ring for pressure transmitter (only VC)	67.08.655.00 67.08.132.00	67.08.655.00 67.08.132.00	67.08.655.00 67.08.132.00	67.08.655.00 67.08.132.00	67.08.655.00 67.08.132.00
19	Sealing ring pressure transmitter (only VC)	30.00.609.00	30.00.609.00	30.00.609.00	30.00.609.00	30.00.609.00
20	Adjusting washer pressure transmitter (only VC)	66.50.018.00	66.50.018.00	66.50.018.00	66.50.018.00	66.50.018.00
21	Counternut pressure transmitter (only VC)	67.97.090.00	67.97.090.00	67.97.090.00	67.97.090.00	67.97.090.00
22	Cable gland	87.06.090.00	87.06.090.00	87.06.090.00	87.06.090.00	87.06.090.00
23	Blind plug	87.05.092.00	87.05.092.00	87.05.092.00	87.05.092.00	87.05.092.00
24	Outer grounding	30.00.503.00 1x 62.80.611.00 3x 62.62.519.00 2x 30.00.382.00 1x	30.00.503.00 1x 62.80.611.00 3x 62.62.519.00 2x 30.00.382.00 1x	30.00.503.00 1x 62.80.611.00 3x 62.62.519.00 2x 30.00.382.00 1x	30.00.503.00 1x 62.80.611.00 3x 62.62.519.00 2x 30.00.382.00 1x	30.00.503.00 1x 62.80.611.00 3x 62.62.519.00 2x 30.00.382.00 1x

25	Name plate	order specific, specify device serial number	order specific, specify device serial number	order specific, specify device serial number	order specific, specify device serial number	order specific, specify device serial number
26	Battery (cable included)	98800-16560 92102-00200	98800-16560 92102-00200	98800-16560 92102-00200	98800-16560 92102-00200	98800-16560 92102-00200
27	Battery cover	30.00.597.00	30.00.597.00	30.00.597.00	30.00.597.00	30.00.597.00
28	Electronic (preconfigured) LCD display included	98800-16296	98800-16296	98800-16296	98800-16296	98800-16296
29	LCD display	91501-00370	91501-00370	91501-00370	91501-00370	91501-00370
30	Power module	98800-16590	98800-16590	98800-16590	98800-16590	98800-16590
31	Cover with spiral spring and sealing	00.66.083.00 1x 00.66.145.00 1x 30.00.374.00 2x	00.66.083.00 1x 00.66.145.00 1x 30.00.374.00 2x	00.66.083.00 1x 00.66.145.00 1x 30.00.374.00 2x	00.66.083.00 1x 00.66.145.00 1x 30.00.374.00 2x	00.66.083.00 1x 00.66.145.00 1x 30.00.374.00 2x
32	Electronic meter head complete	98800-17120 VM 98800-17130 0.8-2.5bar 98800-17140 0.8-6bar 98800-17160 2-10bar 98800-17170 4-20bar 98800-17370 4-40bar	98800-17120 VM 98800-17130 0.8-2.5bar 98800-17140 0.8-6bar 98800-17160 2-10bar 98800-17170 4-20bar 98800-17370 4-40bar	98800-17120 VM 98800-17130 0.8-2.5bar 98800-17140 0.8-6bar 98800-17160 2-10bar 98800-17170 4-20bar 98800-17370 4-40bar	98800-17120 VM 98800-17130 0.8-2.5bar 98800-17140 0.8-6bar 98800-17160 2-10bar 98800-17170 4-20bar 98800-17370 4-40bar	98800-17120 VM 98800-17130 0.8-2.5bar 98800-17140 0.8-6bar 98800-17160 2-10bar 98800-17170 4-20bar 98800-17370 4-40bar

TME 400-VM/VC (DN 150-DN 400)

Dr. no.	Article description	DN150	DN200	DN250	DN300	DN400
1	Measuring chamber complete with lubrication	00.52.960.00	00.50.310.00	00.51.937.00	00.52.868.00	00.51.921.00
1	Measuring chamber complete without lubrication	00.50.279.00	-	-	-	-
2	Front ball bearing	65.19.355.00	65.19.356.00	65.19.359.00	65.19.359.00	65.19.361.00
3	Rear ball bearing	65.19.355.00	65.19.353.00	65.19.356.00	65.19.356.00	65.19.359.00
4	Drive shaft	00.50.282.00	00.50.313.00	00.59.099.00	00.52.864.00	00.52.815.00
5	Disk and magnet (screw and ring included)	00.50.283.00 1x 62.41.111.00 2x 90.50.334.00 2x 66.64.530.00 1x	00.50.315.00 1x 90.50.334.00 2x 62.40.121.00 2x	00.51.929.00 1x 62.40.121.00 2x 90.50.334.00 2x	00.52.865.00 1x 62.38.905.00 2x 90.50.334.00 2x	00.51.920.00 1x 62.38.905.00 2x 90.50.334.00 2x
6	Turbine wheel 45° aluminium Turbine wheel 30° aluminium Turbine wheel 45° plastic Turbine wheel 30° plastic Turbine wheel bushing Screws turbine wheel aluminium Set screw turbine wheel aluminium Woodruff key	00.46.566.00 00.47.999.01 00.46.739.00 00.49.530.00 00.46.633.00 1x 61.24.221.00 3x 62.40.782.00 1x	00.46.567.00 00.46.877.00 00.52.934.00 00.52.952.00 00.47.270.00 1x 60.64.035.00 3x	00.46.565.00 00.46.878.00 - - 00.46.619.00 1x 60.64.066.00 4x	00.46.569.00 - 00.46.879.00 - 00.47.242.00 1x 60.64.066.00 4x	00.47.196.00 - 00.47.197.00 - 00.47.244.00 1x 60.64.066.00 4x
		-	64.58.030.00 1x	64.58.040.00 1x	64.58.040.00 1x	64.58.040.00 1x

7	Nut turbine wheel	62.66.074.00 90.59.266.00	62.66.078.00 90.59.266.00	62.66.082.00 90.59.266.00 for PN10,16,25,ANSI150 90.59.265.00 for PN40 and above	62.66.082.00 90.59.265.00	62.66.082.00 90.59.265.00
9	Rückschlagventil / check valve	84.08.021.00	84.08.021.00	84.08.021.00	84.08.021.00	84.08.021.00
10	Flow straightener with screws	80.30.003.00 1x 61.34.211.00 2x	00.47.264.00 1x 61.34.211.00 2x	00.47.536.00 1x 61.34.238.00 3x	00.47.528.00 1x 61.34.238.00 3x	00.64.650.00 1x 61.34.266.00 3x
11	Seal for screw connector	00.60.316.00	00.60.316.00	00.60.316.00	00.60.316.00	00.60.316.00
12	Screw-in connector (standard)	67.00.215.00	67.00.215.00	67.00.205.00	67.00.215.00	67.00.215.00
13	Thermowells	00.55.518.14	00.55.518.14	00.54.365.14	00.54.365.14	00.58.647.14
14	Sealing ring G1/4 Sealing ring G3/8	81.54.614.00 -	81.54.614.00 -	81.54.614.00 therm. 81.54.374.00 Pm	81.54.614.00 -	81.54.614.00 -
15	Sensor VM	01.64.368.06 for ductile cast iron and steel cast bodies 01.64.368.08 for round material bodies A600RF	01.64.368.08 for ductile cast iron and steel cast bodies PN10,16,A150 01.64.368.09 for round material bodies A300 and steel cast bodies PN25/40 01.64.368.10 for round material bodies A600	01.64.368.10 for welding bodies and round material bodies A300 01.64.368.13 for round material bodies A600	01.64.368.11 01.64.368.12	01.64.368.11 01.64.368.12
15	Sensor VC	01.64.368.36 for ductile cast iron and steel cast bodies 01.64.368.66 class A for ductile cast iron and steel cast bodies 01.64.368.38 for round material bodies A600RF 01.64.368.68 class A for round material bodies A600RF	01.64.368.38 for ductile cast iron and steel cast bodies PN10,16,A150 01.64.368.68 class A for ductile cast iron and steel cast bodies PN10,16,A150 01.64.368.39 for round material bodies A300 and steel cast bodies PN25/40 01.64.368.69 class A for round material bodies A300 and steel cast bodies PN25/40	01.64.368.40 for welding bodies and round material bodies A300 01.64.368.70 class A for welding bodies and round material bodies A300 01.64.368.43 for round material bodies A600 01.64.368.73 class A for round material bodies A600	01.64.368.41 01.64.368.71 class A	01.64.368.42 01.64.368.72 class A

15	Sensor VC			01.64.368.40 for round material bodies A600 01.64.368.70 class A for round material bodies A600			
16	Locking plate (only VC)	00.67.200.00	00.67.200.00	00.67.200.00	00.67.200.00	00.67.200.00	00.67.200.00
17	Pressure transmitter (only VC)	98800-17180 0.8-2.5 bar 98800-17190 0.8-6 bar 98800-17200 2-10 bar 98800-17210 4-20 bar 98800-17360 8-40 bar	98800-17180 0.8-2.5 bar 98800-17190 0.8-6 bar 98800-17200 2-10 bar 98800-17210 4-20 bar 98800-17360 8-40 bar	98800-17180 0.8-2.5 bar 98800-17190 0.8-6 bar 98800-17200 2-10 bar 98800-17210 4-20 bar 98800-17360 8-40 bar	98800-17180 0.8-2.5 bar 98800-17190 0.8-6 bar 98800-17200 2-10 bar 98800-17210 4-20 bar 98800-17360 8-40 bar	98800-17180 0.8-2.5 bar 98800-17190 0.8-6 bar 98800-17200 2-10 bar 98800-17210 4-20 bar 98800-17360 8-40 bar	98800-17180 0.8-2.5 bar 98800-17190 0.8-6 bar 98800-17200 2-10 bar 98800-17210 4-20 bar 98800-17360 8-40 bar
18	Cap nut and compression ring for pressure transmitter (only VC)	67.08.655.00	67.08.655.00	67.08.655.00	67.08.655.00	67.08.655.00	67.08.655.00
19	Sealing ring pressure transmitter (only VC)	67.08.132.00	67.08.132.00	67.08.132.00	67.08.132.00	67.08.132.00	67.08.132.00
20	Adjusting washer pressure transmitter (only VC)	30.00.609.00	30.00.609.00	30.00.609.00	30.00.609.00	30.00.609.00	30.00.609.00
		66.50.018.00	66.50.018.00	66.50.018.00	66.50.018.00	66.50.018.00	66.50.018.00
21	Counternut pressure transmitter (only VC)	67.97.090.00	67.97.090.00	67.97.090.00	67.97.090.00	67.97.090.00	67.97.090.00
22	Cable gland	87.06.090.00	87.06.090.00	87.06.090.00	87.06.090.00	87.06.090.00	87.06.090.00
23	Blind plug	87.05.092.00	87.05.092.00	87.05.092.00	87.05.092.00	87.05.092.00	87.05.092.00
24	Outer grounding	30.00.503.00 1x 62.80.611.00 3x 62.62.519.00 2x 30.00.382.00 1x	30.00.503.00 1x 62.80.611.00 3x 62.62.519.00 2x 30.00.382.00 1x	30.00.503.00 1x 62.80.611.00 3x 62.62.519.00 2x 30.00.382.00 1x	30.00.503.00 1x 62.80.611.00 3x 62.62.519.00 2x 30.00.382.00 1x	30.00.503.00 1x 62.80.611.00 3x 62.62.519.00 2x 30.00.382.00 1x	30.00.503.00 1x 62.80.611.00 3x 62.62.519.00 2x 30.00.382.00 1x
25	Typenschild / name plate	order specific, specify device serial number	order specific, specify device serial number	order specific, specify device serial number	order specific, specify device serial number	order specific, specify device serial number	order specific, specify device serial number
26	Battery (cable included)	98800-16560 92102-00200	98800-16560 92102-00200	98800-16560 92102-00200	98800-16560 92102-00200	98800-16560 92102-00200	98800-16560 92102-00200
27	Battery cover	30.00.597.00	30.00.597.00	30.00.597.00	30.00.597.00	30.00.597.00	30.00.597.00
28	Electronic (preconfigured) LCD display included	98800-16296	98800-16296	98800-16296	98800-16296	98800-16296	98800-16296
29	LCD display	91501-00370	91501-00370	91501-00370	91501-00370	91501-00370	91501-00370
30	Power module	98800-16590	98800-16590	98800-16590	98800-16590	98800-16590	98800-16590
31	Cover with spiral spring and sealing	00.66.083.00 1x 00.66.145.00 1x 30.00.374.00 2x	00.66.083.00 1x 00.66.145.00 1x 30.00.374.00 2x	00.66.083.00 1x 00.66.145.00 1x 30.00.374.00 2x	00.66.083.00 1x 00.66.145.00 1x 30.00.374.00 2x	00.66.083.00 1x 00.66.145.00 1x 30.00.374.00 2x	00.66.083.00 1x 00.66.145.00 1x 30.00.374.00 2x
32	Electronic meter head complete	98800-17120 VM 98800-17130 0.8-2.5bar 98800-17140 0.8-6bar 98800-17160 2-10bar 98800-17170 4-20bar	98800-17120 VM 98800-17130 0.8-2.5bar 98800-17140 0.8-6bar 98800-17160 2-10bar 98800-17170 4-20bar	98800-17120 VM 98800-17130 0.8-2.5bar 98800-17140 0.8-6bar 98800-17160 2-10bar 98800-17170 4-20bar	98800-17120 VM 98800-17130 0.8-2.5bar 98800-17140 0.8-6bar 98800-17160 2-10bar 98800-17170 4-20bar	98800-17120 VM 98800-17130 0.8-2.5bar 98800-17140 0.8-6bar 98800-17160 2-10bar 98800-17170 4-20bar	98800-17120 VM 98800-17130 0.8-2.5bar 98800-17140 0.8-6bar 98800-17160 2-10bar 98800-17170 4-20bar

Parts of the versions TME 400-VMF and TME 400-VCF

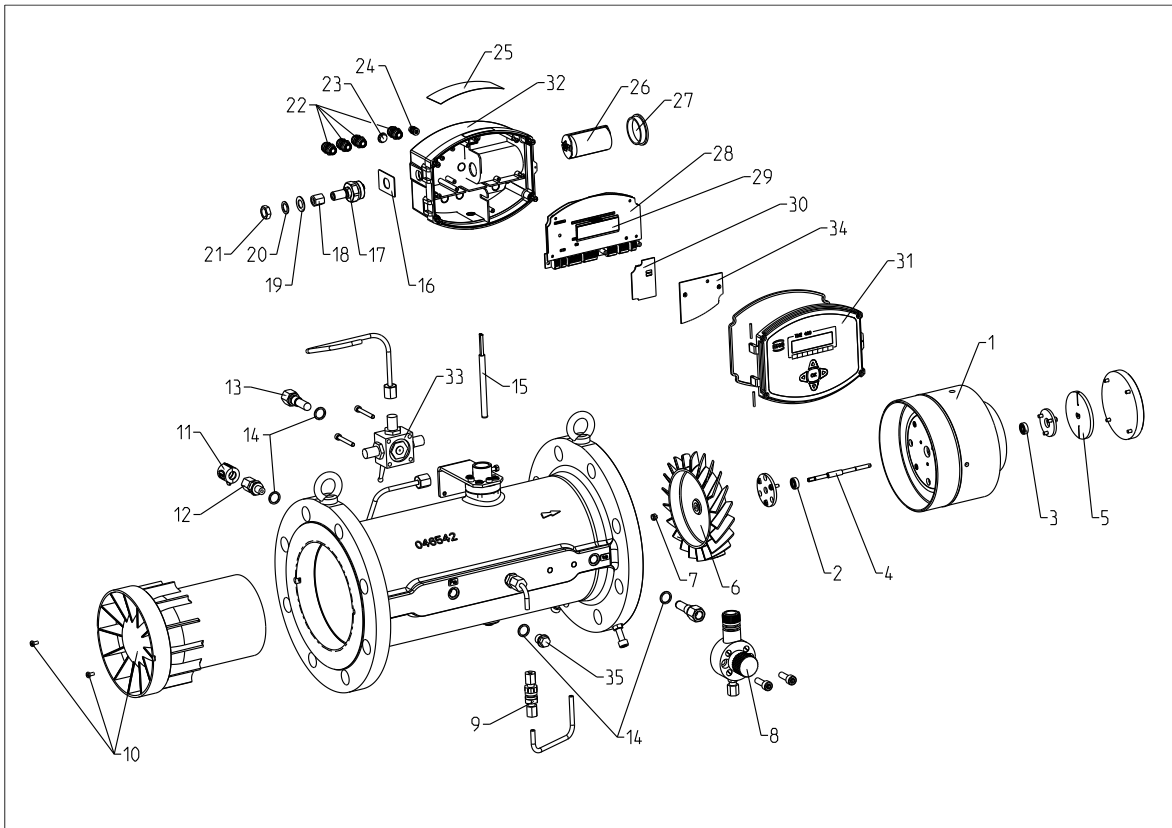

135

The spare parts marked in red in the following tables are intended exclusively for replacement by RMG service partners!

TME 400-VMF/VCF (DN 50-DN 150)

Dr.no.	Article description	DN50	DN80	DN100	DN150
1	Measuring chamber complete with lubrication	00.65.957.00	00.49.655.00	00.50.253.00	00.52.960.00
1	Measuring chamber complete without lubrication	00.65.959.00	00.52.945.00	00.53.409.00	00.50.279.00
2	Front ball bearing	65.19.372.00	65.19.351.00	65.19.352.00	65.19.355.00
3	Rear ball bearing	30.00.399.00	65.19.372.00	65.19.380.00	65.19.355.00
4	Drive shaft	00.50.231.00	00.64.257.00	00.50.348.00	00.50.282.00
5	Disk and magnet (screw and ring included)	Integrated in drive shaft dr.-pos. 4	Integrated in drive shaft dr.-pos. 4	00.64.258.00 1x 66.64.515.00 1x	00.50.283.00 1x 62.41.111.00 2x 90.50.334.00 2x 66.64.530.00 1x
6	Turbine wheel 45° aluminium	00.47.680.00	00.46.745.00	00.46.471.00	00.46.566.00
	Turbine wheel 30° aluminium	-	00.48.224.00	00.48.046.00	00.47.999.01
	Turbine wheel 45° plastic	00.47.110.00	00.46.743.00	00.46.472.00	00.46.739.00
	Turbine wheel 30° plastic	-	00.49.528.00	00.49.529.00	00.49.530.00
	Turbine wheel (aluminium) bushing	-	00.46.811.00 1x	00.60.235.00 1x	00.46.633.00 1x
	Screws turbine wheel aluminium	-	61.22.079.00 2x	61.24.152.00 3x	61.24.221.00 3x
	Set screw turbine wheel aluminium	-	62.40.109.00 1x	62.40.109.00 1x	62.40.782.00 1x
	Set screw turbine wheel plastic	-	-	64.34.012.00 1x	-
7	Nut turbine wheel	62.66.070.00	62.66.070.00	62.66.072.00	62.66.074.00
8	Lubrication pump	90.59.266.00	90.59.266.00	90.59.266.00	90.59.266.00
9	Check valve	84.08.021.00	84.08.021.00	84.08.021.00	84.08.021.00
10	Flow straightener with screws	00.47.170.00 1x 61.34.211.00 2x	00.46.628.00 1x 61.34.211.00 2x	00.46.494.00 1x 61.34.211.00 2x	00.46.543.00 1x 61.34.211.00 2x
11	Seal for screw connector	00.60.316.00	00.60.316.00	00.60.316.00	00.60.316.00
12	Screw-in connector (standard)	67.00.215.00	67.00.215.00	67.00.215.00	67.00.215.00
13	Thermowells	00.56.533.14	00.55.523.14	00.55.518.14	00.55.518.14
14	Sealing ring G1/4	81.54.614.00	81.54.614.00	81.54.614.00	81.54.614.00
15	Sensor VMF	01.64.492.00 for ductile cast iron bodies 01.64.492.01 for steel cast bodies	01.64.492.02 for ductile cast iron bodies 01.64.492.03 for steel cast bodies	01.64.492.04 for ductile cast iron bodies 01.64.492.05 for steel cast bodies	01.64.492.06 for ductile cast iron bodies 01.64.492.07 for steel cast bodies
15	Sensor VCF	01.64.492.32 for ductile cast iron bodies 01.64.492.62 class A for ductile cast iron bodies	01.64.492.30 for ductile cast iron bodies 01.64.492.60 class A for ductile cast iron bodies	01.64.492.34 for ductile cast iron bodies 01.64.492.64 class A for ductile cast iron bodies	01.64.492.36 for ductile cast iron bodies 01.64.492.66 class A for ductile cast iron bodies

15	Sensor VCF	01.64.492.02 alternative with PT1000 for ductile cast iron bodies 01.64.492.33 for steel cast bodies 01.64.492.63 class A for steel cast bodies 01.64.492.03 alternative with PT1000 for steel cast bodies	01.64.492.00 alternative with PT1000 for ductile cast iron bodies 01.64.492.31 for steel cast bodies 01.64.492.61 class A for steel cast bodies 01.64.492.01 alternative with PT1000 for steel cast bodies	01.64.492.04 alternative with PT1000 for ductile cast iron bodies 01.64.492.35 for steel cast bodies 01.64.492.65 class A for steel cast bodies 01.64.492.05 alternative with PT1000 for steel cast bodies	01.64.492.06 alternative with PT1000 for ductile cast iron bodies 01.64.492.37 for steel cast bodies 01.64.492.67 class A for steel cast bodies 01.64.492.07 alternative with PT1000 for steel cast bodies
16	Locking plate (only VCF)	00.67.200.00	00.67.200.00	00.67.200.00	00.67.200.00
17	Pressure transmitter (only VCF)	98800-17180 0.8-2.5 bar 98800-17190 0.8-6 bar 98800-17200 2-10 bar 98800-17210 4-20 bar 98800-17360 8-40 bar	98800-17180 0.8-2.5 bar 98800-17190 0.8-6 bar 98800-17200 2-10 bar 98800-17210 4-20 bar 98800-17360 8-40 bar	98800-17180 0.8-2.5 bar 98800-17190 0.8-6 bar 98800-17200 2-10 bar 98800-17210 4-20 bar 98800-17360 8-40 bar	98800-17180 0.8-2.5 bar 98800-17190 0.8-6 bar 98800-17200 2-10 bar 98800-17210 4-20 bar 98800-17360 8-40 bar
18	Cap nut and compression ring for pressure transmitter (only VCF)	67.08.655.00 67.08.132.00	67.08.655.00 67.08.132.00	67.08.655.00 67.08.132.00	67.08.655.00 67.08.132.00
19	Sealing ring pressure transmitter (only VCF)	30.00.609.00	30.00.609.00	30.00.609.00	30.00.609.00
20	Adjusting washer pressure transmitter (only VCF)	66.50.018.00	66.50.018.00	66.50.018.00	66.50.018.00
21	Counternut pressure transmitter (only VCF)	67.97.090.00	67.97.090.00	67.97.090.00	67.97.090.00
22	Cable gland	87.06.090.00	87.06.090.00	87.06.090.00	87.06.090.00
23	Blind plug	87.05.092.00	87.05.092.00	87.05.092.00	87.05.092.00
24	Outer grounding	30.00.503.00 1x 62.80.611.00 3x 62.62.519.00 2x 30.00.382.00 1x	30.00.503.00 1x 62.80.611.00 3x 62.62.519.00 2x 30.00.382.00 1x	30.00.503.00 1x 62.80.611.00 3x 62.62.519.00 2x 30.00.382.00 1x	30.00.503.00 1x 62.80.611.00 3x 62.62.519.00 2x 30.00.382.00 1x
25	Name plate	order specific, specify device serial number	order specific, specify device serial number	order specific, specify device serial number	order specific, specify device serial number
26	Battery (cable included)	98800-16560 92102-00200	98800-16560 92102-00200	98800-16560 92102-00200	98800-16560 92102-00200
27	Battery cover	30.00.597.00	30.00.597.00	30.00.597.00	30.00.597.00
28	Electronic (preconfigured) LCD display included	98800-16296	98800-16296	98800-16296	98800-16296
29	LCD display	91501-00370	91501-00370	91501-00370	91501-00370
30	Power module	98800-16590	98800-16590	98800-16590	98800-16590

31	Cover with spiral spring and sealing	00.66.083.00 1x 00.66.145.00 1x 30.00.374.00 2x	00.66.083.00 1x 00.66.145.00 1x 30.00.374.00 2x	00.66.083.00 1x 00.66.145.00 1x 30.00.374.00 2x	00.66.083.00 1x 00.66.145.00 1x 30.00.374.00 2x
32	Electronic meter head complete	98800-17120 VMF 98800-17130 0.8-2.5bar 98800-17140 0.8-6bar 98800-17160 2-10bar 98800-17170 4-20bar 98800-17370 4-40bar	98800-17120 VM 98800-17130 0.8-2.5bar 98800-17140 0.8-6bar 98800-17160 2-10bar 98800-17170 4-20bar 98800-17370 4-40bar	98800-17120 VM 98800-17130 0.8-2.5bar 98800-17140 0.8-6bar 98800-17160 2-10bar 98800-17170 4-20bar 98800-17370 4-40bar	98800-17120 VM 98800-17130 0.8-2.5bar 98800-17140 0.8-6bar 98800-17160 2-10bar 98800-17170 4-20bar 98800-17370 4-40bar
33	3-way-valve	84.01.908.14 steel galvanized 30.00.646.00 stainless steel	84.01.908.14 steel galvanized 30.00.646.00 stainless steel	84.01.908.14 steel galvanized 30.00.646.00 stainless steel	84.01.908.14 steel galvanized 30.00.646.00 stainless steel
34	Calibration cover with screws	91101-06732 91203-00600 61.76.017.00 2x	91101-06732 91203-00600 61.76.017.00 2x	91101-06732 91203-00600 61.76.017.00 2x	91101-06732 91203-00600 61.76.017.00 2x

TME 400-VMF/VCF (DN 200-DN 300)

Dr.no.	Article description	DN200	DN250	DN300
1	Measuring chamber complete with lubrication	00.50.310.00	00.51.937.00	00.52.868.00
1	Measuring chamber complete without lubrication	-	-	-
2	Front ball bearing	65.19.356.00	65.19.359.00	65.19.359.00
3	Rear ball bearing	65.19.353.00	65.19.356.00	65.19.356.00
4	Drive shaft	00.50.313.00	00.59.099.00	00.52.864.00
5	Disk and magnet (screw and ring included)	00.50.315.00 1x 90.50.334.00 2x 62.40.121.00 2x	00.51.929.00 1x 62.40.121.00 2x 90.50.334.00 2x	00.52.865.00 1x 62.38.905.00 2x 90.50.334.00 2x
6	Turbine wheel 45° aluminium Turbine wheel 30° aluminium Turbine wheel 45° plastic Turbine wheel 30° plastic Turbine wheel (aluminium) bushing Screws turbine wheel aluminium Set screw turbine wheel aluminium Set screw turbine wheel plastic Woodruff key	00.46.567.00 00.46.877.00 00.52.934.00 00.52.952.00 00.47.270.00 1x 60.64.035.00 3x - - 64.58.030.00 1x 62.66.078.00	00.46.565.00 00.46.878.00 - - 00.46.619.00 1x 60.64.066.00 4x - - 64.58.040.00 1x 62.66.082.00	00.46.569.00 - 00.46.879.00 - 00.47.242.00 1x 60.64.066.00 4x - - 64.58.040.00 1x 62.66.082.00
7	Nut turbine wheel	62.66.078.00	62.66.082.00	62.66.082.00

8	Lubrication pump	90.59.266.00	90.59.266.00 for PN10,16,ANSI150 90.59.265.00 for PN25 and above	90.59.265.00
9	Check valve	84.08.021.00	84.08.021.00	84.08.021.00
10	Flow straightener with screws	00.46.597.00 1x 61.34.211.00 2x	00.64.315.00 1x 61.34.238.00 3x	00.64.330.00 1x 61.34.238.00 3x
11	Seal for screw connector	00.60.316.00	00.60.316.00	00.60.316.00
12	Screw-in connector (standard)	67.00.215.00	67.00.215.00	67.00.215.00
13	Thermowells	00.54.365.14	00.54.365.14	00.54.365.14
14	Sealing ring G1/4	81.54.614.00	81.54.614.00	81.54.614.00
15	Sensor VMF	01.64.492.08	01.64.492.10	01.64.492.11
15	Sensor VCF	01.64.492.38 standard 01.64.492.68 class A 01.64.492.08 alternative with PT1000	01.64.492.40 standard 01.64.492.70 class A 01.64.492.10 alternative with PT1000	01.64.492.41 standard 01.64.492.71 class A 01.64.492.11 alternative with PT1000
16	Locking plate (only VCF)	00.67.200.00	00.67.200.00	00.67.200.00
17	Pressure transmitter (only VCF)	98800-17180 0,8-2,5 bar 98800-17190 0,8-6 bar 98800-17200 2-10 bar 98800-17210 4-20 bar 98800-17360 8-40 bar	98800-17180 0,8-2,5 bar 98800-17190 0,8-6 bar 98800-17200 2-10 bar 98800-17210 4-20 bar 98800-17360 8-40 bar	98800-17180 0,8-2,5 bar 98800-17190 0,8-6 bar 98800-17200 2-10 bar 98800-17210 4-20 bar 98800-17360 8-40 bar
18	Cap nut and compression ring for pressure transmitter (only VCF)	67.08.655.00 67.08.132.00	67.08.655.00 67.08.132.00	67.08.655.00 67.08.132.00
19	Sealing ring pressure transmitter (only VCF)	30.00.609.00	30.00.609.00	30.00.609.00
20	Adjusting washer pressure transmitter (only VCF)	66.50.018.00	66.50.018.00	66.50.018.00
21	Counternut pressure transmitter (only VCF)	67.97.090.00	67.97.090.00	67.97.090.00
22	Cable gland	87.06.090.00	87.06.090.00	87.06.090.00
23	Blind plug	87.05.092.00	87.05.092.00	87.05.092.00
24	Outer grounding	30.00.503.00 1x 62.80.611.00 3x 62.62.519.00 2x 30.00.382.00 1x	30.00.503.00 1x 62.80.611.00 3x 62.62.519.00 2x 30.00.382.00 1x	30.00.503.00 1x 62.80.611.00 3x 62.62.519.00 2x 30.00.382.00 1x
25	Name plate	order specific, specify device serial number	order specific, specify device serial number	order specific, specify device serial number
26	Battery (cable included)	98800-16560 92102-00200	98800-16560 92102-00200	98800-16560 92102-00200

27	Battery cover	30.00.597.00	30.00.597.00	30.00.597.00
28	Electronic (preconfigured) LCD display included	98800-16296	98800-16296	98800-16296
29	LCD display	91501-00370	91501-00370	91501-00370
30	Power module	98800-16590	98800-16590	98800-16590
31	Cover with spiral spring and sealing	00.66.083.00 1x 00.66.145.00 1x 30.00.374.00 2x	00.66.083.00 1x 00.66.145.00 1x 30.00.374.00 2x	00.66.083.00 1x 00.66.145.00 1x 30.00.374.00 2x
32	Electronic meter head complete	98800-17120 VM 98800-17130 0.8-2.5bar 98800-17140 0.8-6bar 98800-17160 2-10bar 98800-17170 4-20bar 98800-17370 4-40bar	98800-17120 VM 98800-17130 0.8-2.5bar 98800-17140 0.8-6bar 98800-17160 2-10bar 98800-17170 4-20bar 98800-17370 4-40bar	98800-17120 VM 98800-17130 0.8-2.5bar 98800-17140 0.8-6bar 98800-17160 2-10bar 98800-17170 4-20bar 98800-17370 4-40bar
33	3-way-valve	84.01.908.14 steel galvanized	84.01.908.14 steel galvanized	84.01.908.14 steel galvanized
34	Calibration cover with screws	30.00.646.00 stainless steel 91101-06732 91203-00600 61.76.017.00 2x	30.00.646.00 stainless steel 91101-06732 91203-00600 61.76.017.00 2x	30.00.646.00 stainless steel 91101-06732 91203-00600 61.76.017.00 2x

Order number	Description
--------------	-------------

Expendable materials

92102-00200	Power supply battery
38.11.148.01	Lubricant 2-4°E/20°C TRZ/DKZ 1L
38.11.148.05	Lubricant 2-4°E/20°C TRZ/DKZ 5L

141

Accessories

98800-16590	NonEx TME current module 4-20mA passive
38.02.016.00	EExi supply f.4-20mA current output
86.98.211.01	Power supply 24V/DC 1.4A surface mounted
86.98.249.00	Ex-i power supply 24 V
30.00.619.00	Transmitter power supply KFD2-STC5-1
30.00.733.00	Transmitter power supply KFD2-STC5-Ex1
35.00.013.00	Isolating amplifier TURCK IM1-12-T
30.00.019.00	Interface/pulse separating module Datcom K3
35.00.000.00	PS (230V/AC - 12V/DC) for K3 module
86.76.553.00	OMRON DC/DC adapter for Datcom K3

J Certificates and approvals

The **TME400** is approved for custody-transfer measurements. Approvals are available for operation in hazardous environments and for the Pressure Equipment Directive, which are provided as copies in the appendix.

1. EU Declaration of Conformity
2. NMI Evaluation Certificate
3. ATEX
4. IECEX
5. EU-Type Examination Certificate Directive 2014/34/EU
6. PED Module D
7. EU-Type Examination Certificate Module B Directive 2014/68/EU
8. Production Quality Assurance

Unfortunately, paper is not updated automatically, whereas technical development continuously advances. Therefore, we reserve the right to make technical changes in regard to the representations, specifications and certificates of these operating instructions. The latest version of this manual (and other devices) can be downloaded at your convenience from our Internet page:

www.rmg.com.

EU-Declaration of Conformity
EU-Konformitätserklärung



We **RMG Messtechnik GmbH**
 wir Otto – Hahn – Straße 5
 35510 Butzbach
 Germany

Declare under our sole responsibility that the product is in conformity with the directives. Product is labeled according to the listed directives and standards and in accordance with the Type-Examination.
 Erklären in alleiniger Verantwortung, dass das Produkt konform ist mit den Anforderungen der Richtlinien. Das entsprechend gekennzeichnete Produkt ist nach den aufgeführten Richtlinien und Normen hergestellt und stimmt mit dem Baumuster überein.

Product **Turbine Meter TME400VM / Volume Corrector TME400VC**
 Produkt **Turbinenradgaszähler TME400VM / Zustandsmengennummerwerter TME400VC**

Harmonisation Legislations <i>Harmonisierungsrechtsvorschriften</i>	EMV	ATEX	PED
EU- Directives <i>EU-Richtlinie</i>	2014/30/EU	2014/34/EU	2014/68/EU
Marking <i>Kennzeichen</i>	—	II 2G Ex ia IIC T4 Gb	—
Normative Documents <i>Normative Dokumente</i>	EN 61000-6-3:2012 EN 61000-4-2:2009 EN 61000-4-3:2011 EN 61000-4-4:2013 EN 61000-4-5:2015 EN 61000-4-6:2014 EN 61000-4-8:2010 EN 61000-6-29:2001	EN 60079-0:2012 + A11:2013 EN 60079-11:2012	AD 2000 – Merkblätter
EU Type-Examination issued by <i>EU-Baumusterprüfung ausgestellt durch</i>	Prüfbericht Test Report: 1-5557/17-01-03_A (Fa. CTC advanced)	Modul B TÜV 17 ATEX 207566 X TÜV Nord CERT GmbH Germany	Modul B ISG-22-12-1979_Rev. M TÜV Hessen Germany
Approval of a Quality System by <i>Anerkennung eines Qualitätssicherungssystems durch</i>	—	Modul D BVS 17 ATEX ZQS/E139 Notified Body: 0158 DEKRA EXAM Germany	Modul D 73 202 2839 Notified Body: 0091 TÜV Hessen Germany



The object of the declaration described above is in conformity with Directive 2011/65/EU of the European Parliament and of the Council of 8 June 2011 on the restriction of the use of certain hazardous substances in electrical and electronic equipment.
 Der oben beschriebene Gegenstand der Erklärung erfüllt die Vorschriften der Richtlinie 2011/65/EU des Europäischen Parlaments und des Rates vom 8. Juni 2011 zur Beschränkung der Verwendung bestimmter gefährlicher Stoffe in Elektro- und Elektronikgeräten.

RMG Messtechnik GmbH
 Butzbach, den 18.03.2022

Thorsten Dietz
 (CEO)

i.A.
 Sascha Körner
 (Technical Manager)

EU-Declaration of Conformity
EU-Konformitätserklärung



We **RMG Messtechnik GmbH**
 Wir Otto – Hahn – Straße 5
 35510 Butzbach
 Germany

Declare under our sole responsibility that the product is in conformity with the directives. Product is labeled according to the listed directives and standards and in accordance with the Type-Examination.
Erklären in alleiniger Verantwortung, dass das Produkt konform ist mit den Anforderungen der Richtlinien. Das entsprechend gekennzeichnete Produkt ist nach den aufgeführten Richtlinien und Normen hergestellt und stimmt mit dem Baumuster überein.

Product **Turbine Meter with optional EVCD, TME400VMF + TME400VCF**
 Produkt *Turbinenradgaszähler mit ohne Zustandsmengennumwerter, TME400VMF + TME400VCF*

Harmonisation Legislations <i>Harmonisierungsrechtsvorschriften</i>	EMV	ATEX	PED	MID
EU- Directives <i>EU-Richtlinie</i>	2014/30/EU	2014/34/EU	2014/68/EU	2014/32/EU
Marking <i>Kennzeichen</i>	---	II 2G Ex ia IIC T4 Gb	---	
Normative Documents <i>Normative Dokumente</i>	EN 61000-6-3:2012 EN 61000-4-2:2009 EN 61000-4-3:2011 EN 61000-4-4:2013 EN 61000-4-5:2015 EN 61000-4-6:2014 EN 61000-4-8:2010 EN 61000-6-29:2001	EN 60079-0:2018 EN 60079-11:2012	AD 2000 – Merkblätter	EN 12261:2018 EN 12405-1: 2006+A2:2010 Weimec-Guide 7.2
EC Type-Examination issued by <i>EU-Baumusterprüfung ausgestellt von</i>	Prüfbericht/ Test Report: 1-5557/17-01-03_A (Fa. CTC advanced)	Modul B TÜV 17 ATEX 207566 X TÜV Nord CERT GmbH Germany	Modul B ISQ-22-12-1978_Rev. F TÜV Hessen Germany	Modul B T11741 / T11742 NMI Netherlands
Approval of a Quality System by <i>Anerkennung eines Qualitätsicherungssystems durch</i>	---	Modul D BVS 20 ATEX ZOS/E139 Notified Body: 0158 DEKRA EXAM Germany	Modul D 73 202 2839 Notified Body: 0091 TÜV Hessen Germany	Modul D DE-M-AQ-PT8023 Notified Body: 0102 PTB Germany



The object of the declaration described above is in conformity with Directive 2011/65/EU of the European Parliament and of the Council of 8 June 2011 on the restriction of the use of certain hazardous substances in electrical and electronic equipment.
Der oben beschriebene Gegenstand der Erklärung erfüllt die Vorschriften der Richtlinie 2011/65/EU des Europäischen Parlaments und des Rates vom 8. Juni 2011 zur Beschränkung der Verwendung bestimmter gefährlicher Stoffe in Elektro- und Elektronikgeräten.

RMG Messtechnik GmbH
 Butzbach, den 18.03.2022

Thorsten Dietz
 (CEO)

I.A.
 Sascha Körner
 (Technical Manager)

Sitz der Gesellschaft Butzbach • Registergericht Friedberg HRB 2435
 Geschäftsführung Barbara Baumann, Thorsten Dietz
 Qualitätsmanagement DIN EN ISO 9001:2015



Evaluation Certificate

Number **TC11907** revision 4
Project number 3559303
Page 1 of 1

Issued by	NMi Certin B.V.,																		
In accordance with	<ul style="list-style-type: none"> - WELMEC 8.8, 2017 "General and Administrative Aspects of the Voluntary System of Modular Evaluation of Measuring Instruments under the MID" - European Standard EN 12405-1:2005+A2:2010 "Gas meters – Conversion devices – Part 1: volume conversion". 																		
Producer	RMG Messtechnik GmbH Otto-Hahn-Straße 5 35510 Butzbach Germany																		
Part	<p>A calculating and indicating device, intended to be used as part of an electronic gas-volume conversion device (EVCD) or gas meter</p> <table style="width: 100%; border: none;"> <tr> <td style="width: 60%;">Type</td> <td style="width: 20%;">: TME400-VCF</td> <td style="width: 20%;">(config. 1a/1b*)</td> </tr> <tr> <td></td> <td>: TME400-VMF</td> <td>(config. 2a/2b*)</td> </tr> </table> <table style="width: 100%; border: none;"> <tr> <td style="width: 60%;">Manufacturer's mark or name</td> <td style="width: 40%;">: RMG</td> </tr> <tr> <td>Conversion principle (config. 1a/1b*)</td> <td>: T, PT or PTZ</td> </tr> <tr> <td>Conversion principle (config. 2a/2b*)</td> <td>: None (* see description page 1)</td> </tr> <tr> <td>Ambient temperature range</td> <td>: -25 °C / +55 °C</td> </tr> <tr> <td>Designed for</td> <td>: Condensing and non-condensing humidity</td> </tr> <tr> <td>Environment classes</td> <td>: M2 / E2</td> </tr> </table> <p>The intended location for the instrument is open.</p> <p>Further properties are described in the annexes:</p> <ul style="list-style-type: none"> - Description TC11907 revision 4; - Documentation folder TC11907-3. 	Type	: TME400-VCF	(config. 1a/1b*)		: TME400-VMF	(config. 2a/2b*)	Manufacturer's mark or name	: RMG	Conversion principle (config. 1a/1b*)	: T, PT or PTZ	Conversion principle (config. 2a/2b*)	: None (* see description page 1)	Ambient temperature range	: -25 °C / +55 °C	Designed for	: Condensing and non-condensing humidity	Environment classes	: M2 / E2
Type	: TME400-VCF	(config. 1a/1b*)																	
	: TME400-VMF	(config. 2a/2b*)																	
Manufacturer's mark or name	: RMG																		
Conversion principle (config. 1a/1b*)	: T, PT or PTZ																		
Conversion principle (config. 2a/2b*)	: None (* see description page 1)																		
Ambient temperature range	: -25 °C / +55 °C																		
Designed for	: Condensing and non-condensing humidity																		
Environment classes	: M2 / E2																		
Remark	- This revision replaces the earlier versions except for its documentation folder.																		

Issuing Authority

NMi Certin B.V., Notified Body number 0122
6 September 2022

Certification Board

This document is issued under the provision that no liability is accepted and that the manufacturer shall indemnify third-party liability.

The designation of NMI Certin B.V., as Notified Body can be verified at <http://ec.europa.eu/growth/tools-databases/mandol>

Reproduction of the complete document only is permitted.

This document is digitally signed and sealed. The digital signature can be verified in the blue ribbon at the top of the electronic version of this certificate.



NMI Certin B.V.
 Thijsseweg 11
 2629 JA Delft
 The Netherlands
 T +31 88 636 2332
certin@nmi.nl
www.nmi.nl

		<h2>IECEX Certificate of Conformity</h2>	
<p>INTERNATIONAL ELECTROTECHNICAL COMMISSION IEC Certification System for Explosive Atmospheres <small>for rules and details of the IECEx Scheme visit www.iecex.com</small></p>			
Certificate No.:	IECEX TUN 18.0009X	Page 1 of 4	<u>Certificate history:</u>
Status:	Current	Issue No: 2	Issue 1 (2019-03-15) Issue 0 (2018-07-25)
Date of Issue:	2020-12-09		
Applicant:	RMG Messtechnik GmbH Otto-Hahn-Straße 5 35510 Butzbach Germany		
Equipment:	Electronic gas value corrector TME400 type VC, VM, VCF, VMF		
Optional accessory:	associated connection head		
Type of Protection:	Intrinsic Safety "I"		
Marking:	Ex ia IIC T4 Gb		
Approved for issue on behalf of the IECEx Certification Body:		Thomas Heinen	
Position:		Deputy Head of IECEx Certification Body	
Signature: (for printed version)		_____	
Date:		_____	
1. This certificate and schedule may only be reproduced in full. 2. This certificate is not transferable and remains the property of the issuing body. 3. The Status and authenticity of this certificate may be verified by visiting www.iecex.com or use of this QR Code.			
Certificate issued by:			
TÜV NORD CERT GmbH Hanover Office Am TÜV 1, 30519 Hannover Germany			



IECEX Certificate of Conformity

Certificate No.:	IECEX TUN 18.0009X	Page 2 of 4
Date of issue:	2020-12-09	Issue No: 2
Manufacturer:	RMG Otto-Hahn-Straße 5 35510 Butzbach Germany	
Additional manufacturing locations:		

This certificate is issued as verification that a sample(s), representative of production, was assessed and tested and found to comply with the IEC Standard list below and that the manufacturer's quality system, relating to the Ex products covered by this certificate, was assessed and found to comply with the IECEX Quality system requirements. This certificate is granted subject to the conditions as set out in IECEX Scheme Rules, IECEX 02 and Operational Documents as amended

STANDARDS :
 The equipment and any acceptable variations to it specified in the schedule of this certificate and the identified documents, was found to comply with the following standards

IEC 60079-0:2017 Edition:7.0	Explosive atmospheres - Part 0: Equipment - General requirements
IEC 60079-11:2011 Edition:6.0	Explosive atmospheres - Part 11: Equipment protection by intrinsic safety "I"

This Certificate **does not** indicate compliance with safety and performance requirements other than those expressly included in the Standards listed above.



TEST & ASSESSMENT REPORTS:
 A sample(s) of the equipment listed has successfully met the examination and test requirements as recorded in:

Test Report:
[DE/TUN/ExTR18.0018/02](#)

Quality Assessment Report:
[DE/BVSIQAR08.0011/10](#)

147

		<h2 style="text-align: right;">IECEX Certificate of Conformity</h2>	
Certificate No.:	IECEX TUN 18.0009X	Page 3 of 4	
Date of issue:	2020-12-09	Issue No. 2	
<p>EQUIPMENT: Equipment and systems covered by this Certificate are as follows:</p>			
<p>Description of product: The electronic gas value corrector TME400 type VC, VM, VCF, VMF is an apparatus for use in gas explosion hazardous areas. It is used for gas measuring, control and regulating purposes by detection of pressure, temperature and volume pulses.</p>			
<p>Type code: Electronic gas value corrector TME 400 type VC, VM, VCF,VMF</p>			
<p>Electrical data: See attachment for IECEx TUN 18.0009X issue 02.</p>			
<p>Thermal data: Ambient temperature range: -25 °C ≤ Ta ≤ +55 °C</p>			
<p>SPECIFIC CONDITIONS OF USE: YES as shown below:</p>			
<ol style="list-style-type: none"> 1. Electrostatic charge has to be avoided for all housing parts (TME400 and optional associated connection head). The warning label has to be observed. 2. The earth terminal (TME400 and optional associated connection head) has to be connected with the potential equalization in the explosion hazardous area. 			

		IECEX Certificate of Conformity
Certificate No: IECEX TUN 18.0009X	Page 4 of 4	
Date of issue: 2020-12-09	Issue No: 2	
DETAILS OF CERTIFICATE CHANGES (for issues 1 and above) Proof of conformity of the electronic gas value corrector TME 400 type VC, VM, VCF,VMF to the current version of the standard IEC 60079-0:2017 and evaluation of internal changes.		
Annex: IECEX TUN 18.0009X ISS 02.pdf		

149

TÜV NORD CERT GmbH
 Hannover Office
 Am TÜV 1
 30519 Hannover
 Germany



150

General product information:

Description of product:
 The electronic gas value corrector TME 400 type VC, VM, VCF,VMF is an apparatus for use in gas explosion hazardous areas. It is used for gas measuring, control and regulating purposes by detection of pressure, temperature and volume pulses.

Type code:
 Electronic gas value corrector TME 400 type VC, VM, VCF,VMF

Electrical data:

Supply circuit (Terminal X8; 2 and 3)	in type of protection Intrinsic Safety Ex ia IIC Only for connection to a certified intrinsically safe circuit Maximum values: $U_i = 10.7 \text{ V}$ $I_i = 219 \text{ mA}$ $P_i = 325 \text{ mW}$ Effective internal capacitance: $C_i = 7 \text{ nF}$ Effective internal inductance: $L_i = 300 \text{ }\mu\text{H}$
Supply circuit battery, internal (Plug connector X12; 1 and 2)	connection to internal battery Saft, type LS33600, 17 Ah or XENO, type XL 205-F, 19 Ah
Signal input (Terminals X8; 4 and 5)	in type of protection Intrinsic Safety Ex ia IIC Maximum values: $U_o = 5.9 \text{ V}$ $I_o = 3 \text{ mA}$ $P_o = 5 \text{ mW}$ Characteristic line: linear

Ex ia	IIC		
max. permissible external inductance	200 μH	100 μH	50 μH
max. permissible external capacitance	4100 nF	5000 nF	6200 nF

RS 485 and signal input
(Terminals X8; 6 and 7)

	in type of protection Intrinsic Safety Ex ia IIC Maximum values: $U_o = 5.9 \text{ V}$ $I_o = 60 \text{ mA}$ $P_o = 88 \text{ mW}$ Characteristic line: linear
--	---

Ex ia	IIC		
max. permissible external inductance	1700 μH	700 μH	200 μH
max. permissible external capacitance	2100 nF	2600 nF	3100 nF

P17-F-610

Rev. 01 / 06.18

TÜV NORD CERT GmbH
 Hannover Office
 Am TÜV 1
 30519 Hannover
 Germany



Page 2 of 4
 Attachment to IECEx TUN 18.0009X issue No.: 2

RS 485 and signal input (Terminals X8; 6 and 7)	in type of protection Intrinsic Safety Ex ia IIC Only for connection to a certified intrinsically safe circuit Maximum values: $U_i = 10.7 \text{ V}$ $I_i = 219 \text{ mA}$ $P_i = 325 \text{ mW}$ Effective internal capacitance: $C_i = 2.1 \text{ nF}$ Effective internal inductance: $L_i = 300 \mu\text{H}$		
Pulse output (Terminals X3; 1 ... 6)	in type of protection Intrinsic Safety Ex ia IIC Maximum values: $U_o = 5.9 \text{ V}$ $I_o = 2 \text{ mA}$ $P_o = 3 \text{ mW}$		
	Ex ia	IIC	
	max. permissible external inductance	200 μH	100 μH 50 μH
	max. permissible external capacitance	4100 nF	5000 nF 6200 nF
Pulse output (Terminals X3; 1 ... 6)	in type of protection Intrinsic Safety Ex ia IIC Only for connection to a certified intrinsically safe circuit Maximum values: $U_i = 30 \text{ V}$ $I_i = 120 \text{ mA}$ $P_i = 1.2 \text{ W}$ Effective internal capacitance: $C_i = 3 \text{ nF}$ The effective internal inductance is negligibly small.		
Current output (Terminals X9; 1 and 2)	in type of protection Intrinsic Safety Ex ia IIC Only for connection to a certified intrinsically safe circuit Maximum values: $U_i = 28 \text{ V}$ $I_i = 110 \text{ mA}$ $P_i = 805 \text{ mW}$ Effective internal capacitance: $C_i = 2 \text{ nF}$ Effective internal inductance: $L_i = 300 \mu\text{H}$		
Optional pulse output (Terminals X9; 1 and 2)	in type of protection Intrinsic Safety Ex ia IIC Maximum values: $U_o = 5.9 \text{ V}$ $I_o = 1 \text{ mA}$ $P_o = 1 \text{ mW}$		
	Ex ia	IIC	
	max. permissible external inductance	200 μH	100 μH 50 μH
	max. permissible external capacitance	4100 nF	5000 nF 6200 nF

TÜV NORD CERT GmbH
 Hannover Office
 Am TÜV 1
 30519 Hannover
 Germany



152

Page 3 of 4
 Attachment to IECEx TUN 18.0009X issue No.: 2

Impulse input Reed/Wiegand, internal (Terminals X5; 1 ... 4) in type of protection Intrinsic Safety Ex ia IIC
 Maximum values:
 $U_o = 5.9\text{ V}$
 $I_o = 8\text{ mA}$
 $P_o = 8\text{ mW}$
 Characteristic line: linear

Ex ia	IIC		
max. permissible external inductance	20000 μH	10000 μH	5000 μH
max. permissible external capacitance	1800 nF	1800 nF	2100 nF

Pressure sensor circuit, internal (Terminals X8; 1 ... 4) in type of protection Intrinsic Safety Ex ia IIC
 Maximum values:
 $U_o = 5.9\text{ V}$
 $I_o = 100\text{ mA}$
 $P_o = 148\text{ mW}$
 Characteristic line: linear

Ex ia	IIC	
max. permissible external inductance	30 μH	25 μH
max. permissible external capacitance	4100 nF	2000 nF
Sensor	UTC30	TI-1

Pt1000 temperature input, internal (Terminals X11; 1 and 2) in type of protection Intrinsic Safety Ex ia IIC
 Maximum values:
 $U_o = 5.9\text{ V}$
 $I_o = 9\text{ mA}$
 $P_o = 13\text{ mW}$
 Characteristic line: linear

Ex ia	IIC		
max. permissible external inductance	500 μH	200 μH	100 μH
max. permissible external capacitance	3200 nF	4000 nF	4900 nF

All maximum values L_o and C_o are also allowed to be utilized as concentrated capacitances and as concentrated inductances.

For safety reasons, all intrinsically safe circuits are galvanically interconnected with each other via GND potential and safely galvanically separated from earth potential.

At interconnection of intrinsically safe circuits, the rules for interconnection of intrinsically safe circuits have to be observed.

Thermal data:
 Ambient temperature range: $-25\text{ °C} \leq T_a \leq +55\text{ °C}$

P17-F-610

Rev. 01 / 06.18

TÜV NORD CERT GmbH
 Hannover Office
 Am TÜV 1
 30519 Hannover
 Germany



Page 4 of 4
 Attachment to IECEx TUN 18.0009X issue No. : 2

153

Details of Change:

Proof of conformity of the electronic gas value corrector TME 400 type VC, VM, VCF, VMF to the current version of the standard IEC 60079-0:2017 and evaluation of internal changes. The conformity of the TME 400 electronic gas volume corrector type VC, VM, VCF, VMF with the current version of the IEC 60079-11:2011 standard has already been confirmed in the previous issue.

Specific Conditions of Use

1. Electrostatic charge has to be avoided for all housing parts (TME400 and optional associated connection head). The warning label has to be observed.
2. The earth terminal has to be connected with the potential equalization in the explosion hazardous area (TME400 and optional associated connection head).

Translation

(1) **EU-Type Examination Certificate**

(2) Equipment and protective systems intended for use in potentially explosive atmospheres, **Directive 2014/34/EU**



(3) **Certificate Number** TÜV 17 ATEX 207566 X **issue:** 02

(4) **for the product:** Electronic gas valve corrector TME 400 type VC, VM, VCF, VMF

(5) **of the manufacturer:** **RMG Messtechnik GmbH**

(6) **Address:** Otto-Hahn-Straße 5
35510 Butzbach
Germany

Order number: 8003020989
Date of issue: 2020-11-02

(7) The design of this product and any acceptable variation thereto are specified in the schedule to this EU-Type Examination Certificate and the documents therein referred to.

(8) The TÜV NORD CERT GmbH, Notified Body No. 0044, in accordance with Article 17 of the Directive 2014/34/EU of the European Parliament and the Council of 26 February 2014, certifies that this product has been found to comply with the Essential Health and Safety Requirements relating to the design and construction of products intended for use in potentially explosive atmospheres given in Annex II to the Directive.
The examination and test results are recorded in the confidential ATEX Assessment Report No. 20 203 273833.

(9) Compliance with the Essential Health and Safety Requirements has been assured by compliance with:

EN IEC 60079-0:2018 **EN 60079-11:2012**

except in respect of those requirements listed at item 18 of the schedule.

(10) If the sign "X" is placed after the certificate number, it indicates that the product is subject to the Specific Conditions for Use specified in the schedule to this certificate.

(11) This EU-Type Examination Certificate relates only to the design, and construction of the specified product. Further requirements of the Directive apply to the manufacturing process and supply of this equipment. These are not covered by this certificate.

(12) The marking of the product shall include the following:

II 2 G Ex ia IIC T4 Gb

TÜV NORD CERT GmbH, Langemarkstraße 20, 45141 Essen, notified by the central office of the countries for safety engineering (ZLS), Ident. Nr. 0044, legal successor of the TÜV NORD CERT GmbH & Co. KG Ident. Nr. 0032

The deputy of the head of the notified body

Heinen Digital unterschrieben
von Heinen Thomas
Datum: 2020.11.02
19:01:06 +01'00'

Hanover office, Am TÜV 1, 30519 Hannover, Tel. +49 511 998-61455, Fax +49 511 998-61590

This certificate may only be reproduced without any change, schedule included.
Excerpts or changes shall be allowed by the TÜV NORD CERT GmbH.

(13) **SCHEDULE**

(14) **EU-Type Examination Certificate No. TÜV 17 ATEX 207566 X issue 02**

(15) **Description of product:**

The electronic gas value corrector TME 400 type VC, VM, VCF,VMF is an apparatus for use in gas explosion hazardous areas. It is used for gas measuring, control and regulating purposes by detection of pressure, temperature and volume pulses.

Type code:

Electronic gas value corrector TME 400 type VC, VM, VCF,VMF

Electrical data:

Supply circuit (Terminal X6; 2 and 3)	in type of protection Intrinsic Safety Ex ia IIC Only for connection to a certified intrinsically safe circuit Maximum values: U _i = 10.7 V I _i = 219 mA P _i = 325 mW Effective internal capacitance: C _i = 7 nF Effective internal inductance: L _i = 300 µH
--	--

Supply circuit battery, internal (Plug connector X12; 1 and 2)	connection to internal battery Saft, type LS33600, 17 Ah or XENO, type XL 205-F, 19 Ah
---	--

Signal input (Terminals X6; 4 and 5)	in type of protection Intrinsic Safety Ex ia IIC Maximum values: U _o = 5.9 V I _o = 3 mA P _o = 5 mW Characteristic line: linear
---	--

Ex ia	IIC		
	max. permissible external inductance	200 µH	100 µH
max. permissible external capacitance	4100 nF	5000 nF	6200 nF

RS 485 and signal input (Terminals X6; 6 and 7)	in type of protection Intrinsic Safety Ex ia IIC Maximum values: U _o = 5.9 V I _o = 60 mA P _o = 88 mW Characteristic line: linear
--	--

Ex ia	IIC		
	max. permissible external inductance	1700 µH	700 µH
max. permissible external capacitance	2100 nF	2600 nF	3100 nF

Schedule to EU-Type Examination Certificate No. TÜV 17 ATEX 207566 X issue 02

RS 485 and signal input
(Terminals X6; 6 and 7)

in type of protection Intrinsic Safety Ex ia IIC
Only for connection to a certified intrinsically safe circuit
Maximum values:
 $U_i = 10.7 \text{ V}$
 $I_i = 219 \text{ mA}$
 $P_i = 325 \text{ mW}$
Effective internal capacitance: $C_i = 2.1 \text{ nF}$
Effective internal inductance: $L_i = 300 \text{ }\mu\text{H}$

Pulse output
(Terminals X3; 1 ... 6)

in type of protection Intrinsic Safety Ex ia IIC
Maximum values:
 $U_o = 5.9 \text{ V}$
 $I_o = 2 \text{ mA}$
 $P_o = 3 \text{ mW}$

Ex ia	IIC		
max. permissible external inductance	200 μH	100 μH	50 μH
max. permissible external capacitance	4100 nF	5000 nF	6200 nF

Pulse output
(Terminals X3; 1 ... 6)

in type of protection Intrinsic Safety Ex ia IIC
Only for connection to a certified intrinsically safe circuit
Maximum values:
 $U_i = 30 \text{ V}$
 $I_i = 120 \text{ mA}$
 $P_i = 1.2 \text{ W}$
Effective internal capacitance: $C_i = 3 \text{ nF}$
The effective internal inductance is negligibly small.

Current output
(Terminals X9; 1 and 2)

in type of protection Intrinsic Safety Ex ia IIC
Only for connection to a certified intrinsically safe circuit
Maximum values:
 $U_i = 28 \text{ V}$
 $I_i = 110 \text{ mA}$
 $P_i = 805 \text{ mW}$
Effective internal capacitance: $C_i = 2 \text{ nF}$
Effective internal inductance: $L_i = 300 \text{ }\mu\text{H}$

Optional pulse output
(Terminals X9; 1 and 2)

in type of protection Intrinsic Safety Ex ia IIC
Maximum values:
 $U_o = 5.9 \text{ V}$
 $I_o = 1 \text{ mA}$
 $P_o = 1 \text{ mW}$

Ex ia	IIC		
max. permissible external inductance	200 μH	100 μH	50 μH
max. permissible external capacitance	4100 nF	5000 nF	6200 nF

Schedule to EU-Type Examination Certificate No. TÜV 17 ATEX 207566 X issue 02

Impulse input Reed/Wiegand, internal
(Terminals X5; 1 ... 4)

in type of protection Intrinsic Safety Ex ia IIC
Maximum values:
 $U_o = 5.9 \text{ V}$
 $I_o = 6 \text{ mA}$
 $P_o = 8 \text{ mW}$
Characteristic line: linear

Ex ia	IIC		
max. permissible external inductance	20000 μH	10000 μH	5000 μH
max. permissible external capacitance	1800 nF	1900 nF	2100 nF

Pressure sensor circuit, internal
(Terminals X8; 1 ... 4)

in type of protection Intrinsic Safety Ex ia IIC
Maximum values:
 $U_o = 5.9 \text{ V}$
 $I_o = 100 \text{ mA}$
 $P_o = 148 \text{ mW}$
Characteristic line: linear

Ex ia	IIC	
max. permissible external inductance	30 μH	25 μH
max. permissible external capacitance	4100 nF	2000 nF
Sensor	UTC30	TI-1

Pt1000 temperature input, internal
(Terminals X11; 1 and 2)

in type of protection Intrinsic Safety Ex ia IIC
Maximum values:
 $U_o = 5.9 \text{ V}$
 $I_o = 9 \text{ mA}$
 $P_o = 13 \text{ mW}$
Characteristic line: linear

Ex ia	IIC		
max. permissible external inductance	500 μH	200 μH	100 μH
max. permissible external capacitance	3200 nF	4000 nF	4900 nF

All maximum values L_o and C_o are also allowed to be utilized as concentrated capacitances and as concentrated inductances.

For safety reasons, all intrinsically safe circuits are galvanically interconnected with each other via GND potential and safely galvanically separated from earth potential.

At interconnection of intrinsically safe circuits, the rules for interconnection of intrinsically safe circuits have to be observed.

Thermal data:

Ambient temperature range: $-25 \text{ }^\circ\text{C} \leq T_a \leq +55 \text{ }^\circ\text{C}$

(16) Drawings and documents are listed in the ATEX Assessment Report No. 20 203 273833

Schedule to EU-Type Examination Certificate No. TÜV 17 ATEX 207566 X issue 02

(17) **Specific Conditions for Use**

1. Electrostatic charge has to be avoided for all housing parts (TME400 and optional associated connection head). The warning label has to be observed.
2. The earth terminal has to be connected with the potential equalization in the explosion hazardous area (TME400 and optional associated connection head).

(18) **Essential Health and Safety Requirements**

No additional ones

- End of Certificate -



CERTIFICATE

for a management system as per

Pressure Equipment Directive 2014/68/EU Module D

Evidence of conformity has been furnished.



ONE STEP AHEAD

RMG Messtechnik GmbH
Otto-Hahn-Straße 5
35510 Butzbach
Germany

scope:

Production of gas meters and
associated items of equipment

Certificate registration No. 73 202 2839

Certificate valid from 2021-07-26 to 2024-07-15

Audit report No. 4383 6173



Darmstadt, 2021-07-26
Certification Body of TÜV Hessen
- Head of Certification body -

PAGE 1 OF 1

*pressure certificate has valid until 2021-09-15

This certificate confirms the introduction and maintenance of the Management system specified above and is monitored regularly. The manufacturer is entitled to provide in the context of the scope of pressure equipment devices with CE marking with the identification number 2001 of the notified body of TÜV Hessen. The current validity is verifiable at www.proficert.com. Original certificates contain a glued hologram.
TUV Technische Überwachung Hessen GmbH, Robert-Bosch-Straße 1A, D-64293 Darmstadt, Germany Phone: +49 615 5102331 Rev-GS-2007



1 Production Quality Assurance Notification

2 Equipment and Protective Systems intended for use in potentially explosive atmospheres
 Directive 2014/34/EU
 Annex IV - Module D: Conformity to type based on quality assurance of the production process
 Annex VII - Module E: Conformity to type based on product quality assurance

3 Notification number: **BVS 20 ATEX ZQS/E139**

4 Product category: **Equipment and components
 equipment-group II, category 2G: Manufacturing and sale of Volume Meters,
 Electronic Correctors and Gas Analysers, Electrical equipment and devices**



5 Manufacturer: **RMG Messtechnik GmbH**

6 Address: **Otto-Hahn-Strasse 5, 35510 Butzbach, Germany**

Site(s) of manufacture: **RMG Messtechnik GmbH, Otto-Hahn-Strasse 5, 35510 Butzbach, Germany
 RMG Messtechnik GmbH, Heinrich-Lanz-Strasse 9, 67259 Beindersheim, Germany**

7 The certification body of DEKRA Testing and Certification GmbH, Notified Body No 0158 in accordance with Article 17 of the Council Directive 2014/34/EU of 26 February 2014 notifies that the manufacturer has a production quality system, which complies with Annex IV of the Directive. This quality system in compliance with Annex IV of the Directive also meets the requirements of Annex VII. In the updated annex all products covered by this notification and their type examination certificate numbers are listed.

8 This notification is based on audit report ZQS/E139/20 issued 2020-11-20. Results of periodical re-assessments of the quality system are a part of this notification.

9 This notification is valid from 2020-10-28 until 2023-10-28 and can be withdrawn if the manufacturer does not satisfy the production quality assurance surveillance according to Annex IV and VII.

10 According to Article 16 (3) of the Directive 2014/34/EU the CE marking shall be followed by the identification number 0158 of DEKRA Testing and Certification GmbH as notified body involved in the production control phase.

DEKRA Testing and Certification GmbH
 Bochum, 2020-11-20



Managing Director

This is a translation from the German original.
 In the case of arbitration only the German wording shall be valid and binding.

Page 1 of 1 - Jobnumber 342009000
 This notification may only be reproduced in its entirety and without any change.
 DEKRA Testing and Certification GmbH, Handwerkstr. 10, 70565 Stuttgart, Germany
 Certification body: Dinnendahlstr. 9, 44609 Bochum, Germany
 Phone +49.234.3696-400, Fax +49.234.3696-401, e-mail DTC-Certification-body@dekra.com

Contact

Subject to technical changes

More information

If you would like to learn more about the products and solutions from RMG, visit our website:

www.rmg.com

or contact your local sales representative

RMG Messtechnik GmbH

Otto-Hahn-Straße 5

35510 Butzbach, Germany

Phone: +49 (0) 6033 897 – 0

Fax: +49 (0) 6033 897 – 130

Email: service@rmg.com

