

ULTRASONIC FLOW METER FOR GAS

RSM 200

Ultrasonic Flow Meter RSM 200 with the same mechanical installation as the turbine gas meter, but technically superior. Maintenance-free, battery-operated and many electronic interfaces with integrated volume corrector.



FUNCTIONING AND STRUCTURE

Introduction

The RSM 200 (RMG Sonic Meter) ultrasonic gas meter is based on innovative ultrasonic transit time technology, which has been increasingly replacing mechanical gas meters for high-precision natural gas flow measurements for several years. The RSM 200 is officially approved for calibration and, in the version with an integrated volume converter and associated pressure and temperature measurement, allows the determination of operating and standard volume flow.

The RSM 200 records and archives current flow values, which can be transmitted either directly via pulses or via digital interfaces. In addition, the RSM 200 offers a fully-fledged corrector including pressure and temperature measurement, so that in

addition to the actual flow rate and actual volume, the standard volume flow and standard volume can also be determined. An external corrector is not required. A long life backup battery ensures operational reliability even if an external power supply fails. Self-sufficient battery operation is possible for the calibration period, i.e. for more than 5 years.

RSM 200

RSM 200 designates an officially approved operating volume meter for gases. It is the little brother of the long-established high-precision ultrasonic gas meters for natural gas measurement in high-pressure networks.

Features

- The RSM 200 is officially approved for calibration according to MID 2014/34/EU
- Execution according to DIN ISO 17089
- No moving parts
- No upstream or downstream piping requirement*
- Integrated, officially approved state quantity converter according to EN 12405
- Pressure and temperature measurement, display, output and archiving
- K-factor calculation according to SGERG88, AGA8 GROSS M1/M2 and AGA NX19
- Local display for, among others, Actual volume, standard volume, instantaneous and maximum flow
- Pressure and temperature can be sealed separately from other electronics
- Battery or external power supply (power failure-proof) for the entire calibration period (min. five years)
- Explosion protection: The RSM200 is intrinsically safe and can be used in zones 1 and 2
- Pulse output LF, HF, alarm output, current output (4-20 mA, optional)
- DSfG F instance, serial RS 485 interface for Modbus connection
- Peak value storage (Qb)
- Integrated fail-safe archive of parameters, events and measured values
- RMGViewRSM: Supplied software for convenient parameterization and management of the device and the stored data as well as for remote diagnosis

* with minor and moderate disturbances

FEATURES

Working principle

The RSM 200 is designed for unidirectional flow measurement of dry gases with a hydrogen content of up to 10 mol%. The RSM 200 works by determining the difference in transit time of an ultrasonic pulse with and against the flow. The transducers TD1 and TD2 stand for the measurement opposite and form a measurement path with the distance L. An ultrasonic pulse covers the measurement path from sensor TD1 to transducer TD2 faster with the flow than vice versa against the flow. Physically, this is caused by the entrainment effect of the gas flow, the arrow above the \bar{v} indicates the flow direction.

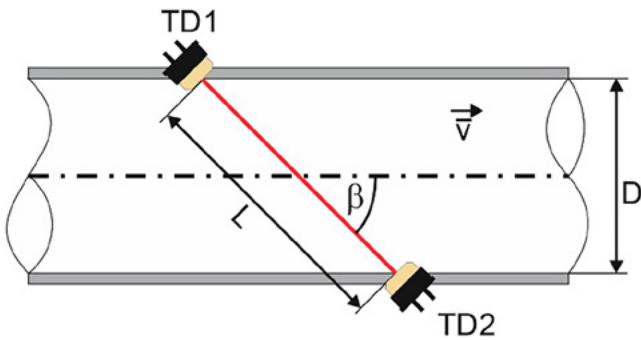

The propagation times of the ultrasonic pulse are determined with the ultrasonic electronics. With t_{TD12} (running times from TD1 to TD2) and t_{TD21} (running times from TD2 to TD1) the average speed \bar{v} along the measuring path can be determined.

$$\bar{v} = \frac{L}{2 \cdot \cos\beta} \cdot \left(\frac{1}{t_{TD12}} - \frac{1}{t_{TD21}} \right)$$

All parameters that depend on the gas are omitted.

The interior of the RSM 200 consists of 3 sections, an inlet for conditioning the flow, a measuring cell and an outlet with an integrated temperature sensor. The inlet with the integrated flow conditioner was optimized using CFD to generate the most laminar flow possible.

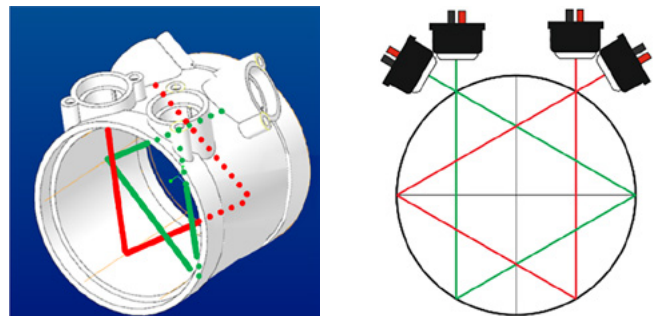

Inside the RSM 200 is the measuring cell with the ultrasonic sensors. In order to determine the velocity averaged over the pipe cross-section, the measuring path is implemented as a Gaussian integration using a double reflection. A second measurement path covers further cross-sectional areas and also records a swirl flow reverse influence on the measurement signal. In total, the influence of a swirl flow is compensated.

The measurement path arrangement determines the mean velocity in the pipe. The volume flow results from the average of the two velocities along the respective measuring paths multiplied by the pipe cross-section A:

$$Q_{measured} = \frac{\bar{v}_1 + \bar{v}_2}{2} \cdot A$$

MEASURING RANGES, PRESSURE LOSS

Measuring ranges

Nominal size mm / inch	Flow rate				Gas velocity in the pipeline ¹⁾			
	Q _{max} [m ³ /h] [cf/h]	Q _t [m ³ /h] [cf/h]	Q _{min} [m ³ /h] [cf/h]	Q _{bco} ²⁾ [m ³ /h] [cf/h]	v (Q _{max}) [m/s] [ft/s]	v (Q _t) [m/s] [ft/s]	v (Q _{min}) [m/s] [ft/s]	v (Q _{bco}) [m/s] [ft/s]
DN 50 / 2"	160 5,650	16 565	1.6 56	0.25 9	22.64 74.28	2.26 7.41	0.14 0.46	0.035 0.11
DN 80 / 3"	400 14,126	40 1,413	2.5 88	0.63 22	22.10 72.51	2.21 7.25	0.14 0.46	0.035 0.11
DN 100 / 4"	650 22,955	65 2,295	3.2 113	1.25 44	22.99 75.43	2.30 7.55	0.11 0.36	0.028 0.09
DN 150 / 6"	1600 56,504	160 5,650	8.0 283	2.00 71	25.15 82.51	2.52 8.27	0.13 0.43	0.033 0.11
DN 200 / 8"	2500 88,287	250 8,829	13.0 459	3.25 115	22.10 72.51	2.21 7.25	0.11 0.36	0.028 0.09

1) To simplify things, the inner diameter Di of the incoming pipe was equated with the value of the nominal values; that means Di (DN50 / 2") = 50 mm = 0.05 m, etc.

2) The recommended setting for the cut-off flow was selected here (Q_{bco} = 0.25 x Q_{min}); Q_{bco} = Measurement cut off rate of the meter

Note: The specified measuring ranges apply to all operating pressures. Metrological testing in air at atmospheric pressure is sufficient to comply with the custody transfer error limits of a Class 1.0 meter. Additional tests with natural gas and/or at higher pressures can increase measurement accuracy. Currently available high-pressure test benches (as of March 2025) are not approved for the entire measuring range of the RSM 200 in the small nominal diameters (DN 50 to DN 100). Therefore, the meters can only be tested at high pressure starting at a Q_{min} of 3 m³/h in natural gas or 5 m³/h in air.

Measurement accuracy

The RSM 200 passed the performance tests according to OIML R137-1&2, Class 1 with light and severe flow disturbance.

Accuracy:	Accuracy class 1.0
Q _t to Q _{max}	≤ ± 1 %
Q _{min} to Q _t	≤ ± 2 %
	Typical error limits after high pressure calibration ≤ ± 0.3 % at test pressure; otherwise:
Q _t to Q _{max}	≤ ± 0.5 %
Q _{min} to Q _t	≤ ± 1 %
Reproducibility:	≤ ± 0,1 %

Pressure loss

The pressure loss of the RSM 200 is lower than that of a comparable turbine. The pressure loss Δp [mbar] is calculated using the following formula:

$$\Delta p_B = Z_p \cdot \rho_B \cdot \left(\frac{Q_B^2}{DN^4} \right)$$

with:

Δp_B = Pressure loss at actual conditions (p_B , Q_B) in mbar

Z_p = Pressure drop coefficient

ρ_B = Operating density in kg/m^3

Q_B = Operating volume flow in m^3/h

DN = Nominal diameter of meter in mm

The pressure loss coefficient Z_p for turbines is typically around 5000, while the RSM 200 has a value of less/approx. 3000.

Approvals

EU type examination according to

- Approved by the calibration authority according to MID 2014/32/EU
- Pressure Equipment Directive PED 2014/68/EU according to certificate
- Explosion protection directive ATEX 2014/34/EU according to certificate Identification: II 2 G Ex ia IIC T4 Gb
- EMC Directive 2014/30/EU according to the test report

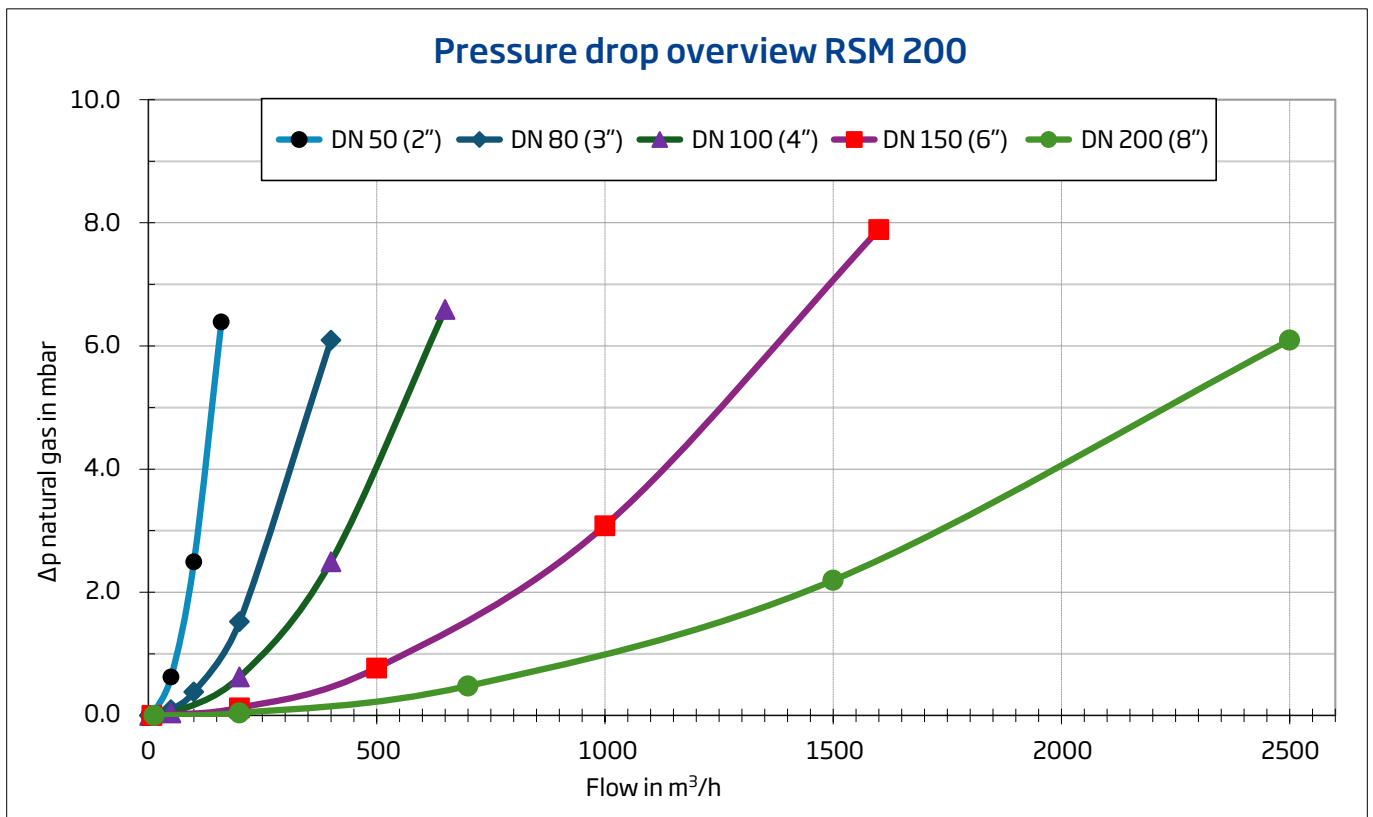

TECHNICAL DATA, GAS TYPES, MATERIALS

Technical Data

Explosion protection	II 2G Ex ia IIC T4 Gb
Protection degree	IP 66
Ambient temperature	-40 °C - +80 °C -40 °F - 176 °F
Temperature range	-40 °C - +70 °C -40 °F - 158 °F
Temperature sensor	Digital temperature sensor EDT 87
Pressure range	0 bar (g) - 20 bar (g) 0 psi (g) - 290 psi (g)
Pressure levels	Flange design PN10, PN16, ANSI150
Pressure sensor	Digital pressure sensor EDT 96
Power supply	Standard Lithium batteries 3.6 V (life cycle > 5 years, calibration period) or external power supply
Output	4 x Digital output: 1 x DO or serial encoder protocol 1 x DO or inverted DO 1 2 x DO: Pulse, status, alarm 1 x Analog output 4 - 20 mA (only with external power supply)
Interfaces	RS 485 (Modbus protocol) / Infrared

Gas types

The components of the gases must be within the concentration limits according to EN 437:2009 for test gases. The gas to be measured must not form any condensates in the working range of the RSM 200 (flow rate, pressure and temperature range) and must be free of corrosive and aggressive

components, liquids and solids. The RSM 200 can be used in hydrogen-containing natural gas. The RSM 200 is suitable for use in natural gases with a maximum hydrogen content of 10 mol% in accordance with the TR-G19 applicable in Germany, with the accuracies specified above.

Materials

Designation	Material
Body	Aluminium or Fine-grained steel (P355QH1)
Flow straightener	Epoxy (3D print)
Measuring cell	Aluminium
Counter header	Aluminium

DIMENSIONS, MOUNTING OPTION

Dimensions

DN 50

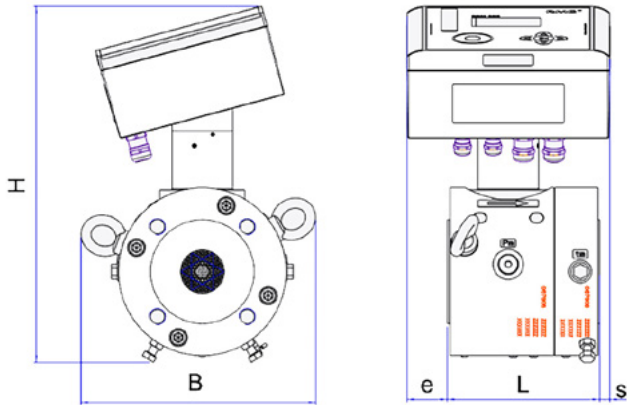

Nominal diameter		Dimensions [mm]					Weight aluminium design
mm	inch	L	B	H	e	s	kg
50	2"	150	231	351	40	10	16

DN 80 - DN 200

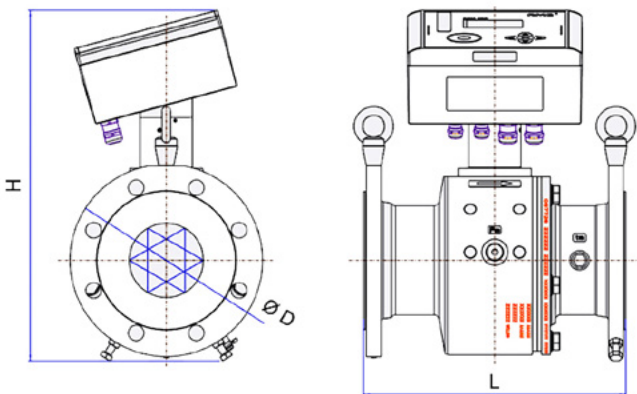

Nominal diameter		Dimensions [mm]			Weight aluminium design
mm	inch	L	D	H	kg
80	3"	240	200	383	18
100	4"	300	220	402	24
150	6"	450	285	464	41
200	8"	600	340	512	65

Electronis housing: 200 mm x 180 mm x 100 mm

Mounting option

The RSM 200 can be supplied with DIN and ANSI flange connections. In principle, the measuring device can be installed in any position for dry, clean gases. In order to reduce the influence of condensate deposits (which should not occur in dry gas), a horizontal installation position is preferable.

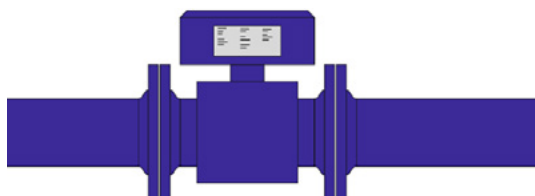

Rotate display

The RSM 200's display faces the viewer and is slightly tilted forwards and downwards; this allows rainwater to run off and improves readability. The orientation of the display can be easily changed and thus adapted to the direction of flow. With this change, the device loses neither its calibration nor its parameterization.

ARCHIVES, OPERATING SOFTWARE

Archives

Parameter changes, flow rate, meter readings, pressure, temperature and events are stored in the archives. The storage depth is (see table on the right):

The measurement period can be set to 15, 30 or 60 minutes.

Event archive	200 entries
Parameter archive (calibrated)	300 entries
Parameter archive (not custody transfer)	300 entries
Monthly archive	25 entriese
Daily archive	100 entries
Period archive	8800 entries

Operating software RMGView^{RSM}

The supplied software RMGViewRSM enables direct access to the measuring electronics with a PC. The most important functions are:

- Reading of all parameters
- Changing parameters (when the calibration switch is open)
- Graphic display of measured values
- Creation of test certificates and data sheets and their issue in pdf format
- Reading out the archives
- Export of parameters and archive data in Excel-readable format

Operation is easy, all values are displayed systematically in graphic form or in clear tables. It is also possible to compile selected measured values and parameters in user-defined tables.

Screenshots (examples):

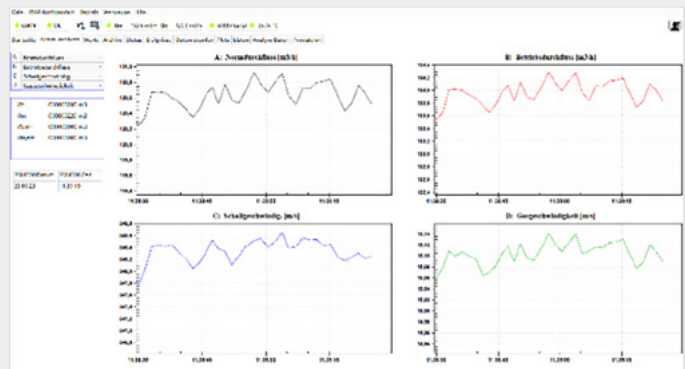
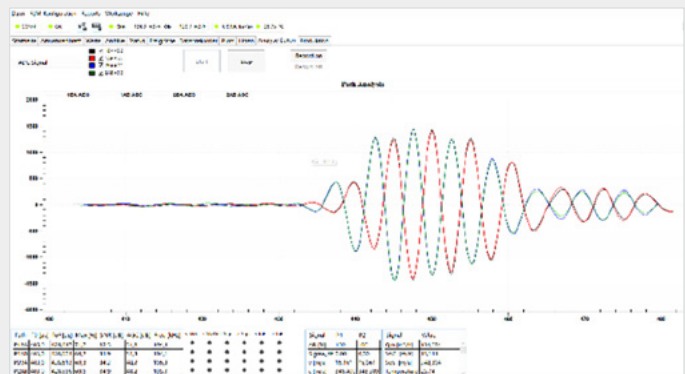



RMG Messtechnik GmbH

Otto-Hahn-Straße 5
35510 Butzbach
Germany

Phone +49 (0) 6033 897-0
Fax +49 (0) 6033 897-130
Email info@rmg.com

www.rmg.com

For more informationen

To learn more about RMG's advanced gas solutions, contact your RMG account manager or visit www.rmg.com