

Operating manual

RGC 7-M – Measuring unit

Issued: September 30th, 2024
Version: 07.1

Manufacturer Contact our customer service department for technical information.

Address	RMG Messtechnik GmbH Otto-Hahn-Straße 5 D-35510 Butzbach (Germany)
Main office	+49 6033 897 – 0
Service-Hotline	+49 6033 897 – 897
Fax	+49 6033 897 – 130
Email	service@rmg.com

Translation of the original document **RGC7-M_manual_de_07.1** is the original manual of September 30th, 2024 for the measuring unit RGC 7-M of the gas chromatograph RGC 7. This document is a template for translations in other languages.

Note The latest version of this manual (and manuals other devices) can be downloaded at your convenience from our Internet page:

www.rmg.com

Created	July	2021
Revision: 01	October	2021
Revision: 02	April	2022
Revision: 03	February	2023
Revision: 04	April	2023
Revision: 05	June	2023
Revision: 06	February	2024
Revision: 07	September	2024

Document version and language	Document version	RGC7-M_manual_en_07.1 September 30th, 2024
	Language	EN

Table of contents

1 ABOUT THIS MANUAL	1	
1.1 Structure of the manual	1	_____
1.2 Purpose of the manual	2	_____
1.2.1 Abbreviations	2	_____
1.2.2 Symbols	3	_____
1.2.3 Structure of notices	3	_____
1.2.4 Working with the device	4	_____
1.2.5 Qualification of personnel	9	_____
1.2.6 Risk assessment and minimization	9	_____
1.2.7 Applicability of the manual	11	_____
1.2.8 Transport	12	_____
1.2.9 Scope of delivery	13	_____
1.2.10 Disposal of packaging material	13	_____
1.2.11 Storage	13	_____
1.3 Explosion-proof design	14	_____
1.3.1 General information	14	_____
1.3.2 Pressure-proof housing	15	_____
1.3.3 Connection housing with elevated safety	15	_____
2 BRIEF INSTRUCTIONS	16	
2.1 Mechanical connection	16	
2.2 Electrical connection	18	
2.3 Commissioning	19	
3 GAS CHROMATOGRAPH RGC 7	20	
3.1 Type designation	20	
3.2 Mode of operation	21	
3.3 Configuration of the measuring unit	24	
3.4 Modularity of the measuring unit system	27	
3.5 Gas distribution	27	
3.6 Gas chromatograph	28	
3.7 Analysis process	30	
3.7.1 Detector	30	
3.7.2 Injection	30	
3.7.3 Back-Flush configuration	31	
3.8 The column module	32	

3.9	Area of application	33
3.10	Data recording and evaluation	33
3.10.1	Basic principles of the analysis	33
3.11	Used gases and gas consumption.....	34
3.11.1	Carrier gas	34
3.11.2	Internal calibration gas	35
3.11.3	Measuring gas.....	36
4	CONNECTION AND COMMISSIONING	37
4.1	Electrical connections	37
4.1.1	Grounding.....	39
4.1.2	PT100 for ambient temperature measurement	40
4.2	Gas connections	41
4.2.1	Carrier gas connection	42
4.2.2	Measuring gas / calibration gas / reference gas.....	42
4.3	Column supply pressure and column temperature.....	43
1.1	Further process	44
1.2	Interruption of the carrier gas supply.....	44
1.3	Inspection and maintenance tasks	46
1.3.1	General information.....	46
1.3.2	Draining condensate from the measuring element.....	48
1.3.3	Changing carrier gas cylinders	49
1.3.4	Replacing the carrier gas filter.....	53
1.3.5	Additional protection from moisture of RGC 704.....	55
2	MEASURING ELEMENT OPERATING MODES	56
2.1	Automatic analysis mode / autorun.....	56
2.2	Stop mode.....	56
2.3	Normal calibration.....	56
2.4	Reference gas analysis.....	56
2.5	Basic calibration.....	57
5	APPENDIX 1: TECHNICAL DATA.....	58
6	APPENDIX 2: ERROR MESSAGES	71
6.1	Appendix 2 A: Error in continuous analysis mode.....	71
6.2	Appendix 2 B: Errors during recalibration	72
6.3	Appendix 2 C: Mains failure of the RGC 7-C	72

7 APPENDIX 3: PRE-FILTER FLUSHING UNIT	73
8 APPENDIX 4: CERTIFICATES	79

1 About this manual

1.1 Structure of the manual

The introduction of this manual essentially comprises three parts. The first part of the introduction lists general specifications, the symbols used in the manual and the structure of notices are presented and a risk assessment is provided. It also includes specifications for transport and storage of the gas chromatograph RGC 7-M.

The RGC 7-M can be operated in explosion-protected zones. The second part of the introduction covers the conditions that must be observed for operation in such areas and describes the explosion protection.

The third part of the introduction describes recurrent inspection and maintenance tasks. Since the RGC 7-M "consumes" gases in order to be able to conduct an analysis of the gas components, these regular maintenance tasks are necessary for the proper function of the RGC 7-M.

The second chapter is a quick guide to connecting the RGC 7-M. In particular, the electrical and mechanical connection is outlined. The "correct" commissioning then takes place together with the controller of the RGC 7-C and is described in the manual.

The method of operation and the intended use of the RGC 7 are described in the third chapter. The fourth chapter describes the electrical and mechanical connections and relevant conditions for further operation. Automated operation and the various calibrations during operation are covered in chapter 5.

The appendix contains the technical data, error messages, information about a flushing unit pre-filter, sample circuit diagrams and a summary of the approvals.

1.2 Purpose of the manual

This manual provides information that is necessary for fault-free and safe operation.

The gas chromatograph RGC 7 was designed and produced according to the state of the art and generally recognized safety standards and directives. However, its use can entail dangers that are avoidable by complying with this manual. The gas chromatograph RGC 7 must only be used as intended and in technically sound condition.

Caution

Unintended use voids all warranty claims and the gas chromatograph RGC 7 can also lose its approvals.

1.2.1 Abbreviations

The following abbreviations are used:

RGC 7	RMG Gas Chromatograph System
RGC 7-M	Measuring unit of RGC 7
RGC 7-C	Controller of RGC 7
approx.	approximately
if applicable	if applicable
max.	maximum
min.	minimum
e.g.	for example
MID	Measurement Instruments Directive
PED	Pressure Equipment Directive
DSfG	Digital interface for gas measuring devices written under the supervision of DVGW
DVGW	German Association for gas and multiples
MessEG	Measurement and Calibration Act Law on the marketing and provision of measuring devices in the market, their use and calibration, valid since 4/19/2016
MessEV	Measurement and Calibration Regulation Regulation on the marketing and provision of measuring devices in the market and on their use and calibration; 12/11/2014

PTB	Physikalisch-Technische Bundesanstalt [German National Test Authority]
-----	--

1.2.2 Symbols

The following symbols are used:

1, 2, ...	Identifies steps for work tasks
..	

1.2.3 Structure of notices

The following notices are used:

 Danger
This warning notice informs you of imminently threatening dangers that can arise due to misuse/operator error. If these situations are not avoided, death or severe injuries can occur.

 Warning
This warning notice informs you of potentially dangerous situations that can arise due to misuse/operator error. If these situations are not avoided, minor injuries can occur.

 Caution
This notice informs you of potentially dangerous situations that can arise due to misuse/operator error. If these situations are not avoided, damage to the device or nearby property can occur.

Note
This notice provides you with helpful tips to make your work easier. This notice also provides you with further information about the device or the work process in order to prevent operator error.

1.2.4 Working with the device

Safety notices Danger, Warning, Caution and Note

Danger

All of the following safety notices must be observed!

Disregard of the safety notices can result in danger to the life and limb or environmental and property damage.

Bear in mind that the safety warnings in this manual and on the device cannot cover all potential dangerous situations, because the interaction of various conditions can be impossible to foresee. Merely following the instructions may not suffice for correct operation. Always remain attentive and consider potential consequences.

- Read this operating manual and especially the following safety notices carefully before working with the device for the first time.
- Warnings are provided in the operating manual for unavoidable residual risks for users, third parties, equipment or other property. The safety instructions used in this manual do not refer to unavoidable residual risks.
- Only operate the device in fault-free condition and in observance of the operating manual.
- Compliance with local statutory accident prevention, installation and assembly regulations is also mandatory.

⚠ Caution
<p>All notices in the manual must be observed.</p> <p>Use of the gas chromatograph RGC 7 is only permitted in accordance with the specifications in the operating manual.</p> <p>RMG assumes no liability for damages arising due to disregard of the operating manual.</p>

⚠ Danger
<p>Service and maintenance tasks or repairs that are not described in the operating manual must not be carried out without prior consultation with the manufacturer.</p>

Observe the following, in particular:

- Changes to the gas chromatograph RGC 7 are not permitted.
- The technical specifications must be observed and followed for safe operation (*Appendix 1: Technical data*). Performance limits must not be exceeded.
- For safe operation, the gas chromatograph RGC 7 must only be used in the scope of the intended use (Chapter 3 *Gas chromatograph RGC 7* and 3.9 *Area of application*)
- The RGC 7 complies with current standards and regulations. However, danger can arise with misuse and the measuring element of the RGC 7 can be destroyed due to operator error.

Dangers during commissioning

Initial commissioning

The initial commissioning must only be carried out by specially trained personnel (training by RMG) or RMG service personnel.

Note

In accordance with Article 15 of the German Ordinance on Industrial Safety and Health (BetrSichV), Article 5 of German Social Accident Insurance (DGUV) REGULATION 3 "Electrical systems and equipment" and generally recognized good engineering practices, particularly the VDE standards VDE 0100-100 "Construction of low-voltage systems" and VDE 0165 "Electrical explosion protection", an inspection of the measuring system must be carried out before the device is commissioned. An acceptance test certificate and corresponding test report must be created for this commissioning. These, the operating manual and the CE Declaration of Conformity must be stored so that they are always readily available. In the process, the entire documentation, including the conformity declarations and certificates must be checked for completeness.

**Danger**

This symbol is used in the manual as a warning of the danger of explosion; observe the instructions following the symbol.

With the danger of explosion, the following must be in particular observed:

- Install the device as specified in the operating manual. If the device is not installed as specified in the operating manual, there may be a risk that other connected devices have adequate explosion protection.

The explosion protection is lost!

- Inadequately qualified persons working on the equipment are unable to correctly estimate dangers. Explosions can be triggered. Only work on the equipment if you have the appropriate qualifications.
- Components can be damaged if you do not use suitable tools and materials. Use tools that are recommended for the respective work in the operating manual.

Mechanical installation	Mechanical installation must only be performed by appropriately qualified technicians.
Electrical installation	Installation on electrical components must only be carried out by qualified electricians.
Mechanical and/or electrical installation	These qualified personnel require training specifically for work in explosion-prone areas. Qualified personnel are persons who have training / education in accordance with DIN VDE 0105, IEC 364 or comparable standards.

⚠ Caution

Before connecting the voltage supply, ensure that all gas lines to the measuring element and the measuring element itself have been flushed. If there is still air in the line system or the measuring element, the measuring element will be destroyed.

⚠ Danger

Connection of pressurized pipelines must only be carried out by trained qualified personnel.

Observe the following:

- Proof of competence of trained qualified personnel and the RMG test report of solder-free pipe fittings must be submitted by the installation company for the commissioning.
- All lines carrying gas must be inspected for tightness and documented in a test report prior to commissioning.

Minimum test pressure of 1.1 times the operating pressure.

- The measuring system must be checked for completeness prior to commissioning.
- Anchor the RGC 7-M on the floor to ensure that it is stable. To do this, use the fixing holes located in the area of the feet.
- Connection of the gas chromatograph RGC 7-M must only take place in an explosion-free, pressure-free atmosphere. The descriptions in the operating manual must be observed for the installation process.
- In general, the setup, connection, or replacement of a gas chromatograph RGC 7-M must only be carried out by RMG Service.

- A leak test must be carried out after work on pressurized components.
- All the above points also apply to repair and maintenance tasks and in general when connection or disconnection of the gas chromatograph RGC 7 is necessary.
- Flange fastening elements, fastening screw couplings and check valves, the oil supply, pressure relief connections, valves, protective pipes and swivel adapters must **not** be loosened during operation.

Dangers during maintenance and repair

Operating personnel	The operating personnel use and operate the device in the scope of the intended use.
Maintenance personnel	Work on the device must only be carried out by qualified personnel who can carry out the respective tasks based on their technical training, experience and familiarity with the applicable standards and requirements. These qualified personnel are familiar with the applicable statutory regulations for accident prevention and can independently recognize and avoid potential dangers.
Maintenance and cleaning	Maintenance and cleaning must only be performed by appropriately qualified technicians.



Danger

Inadequately qualified persons working on the equipment are unable to correctly estimate dangers. Explosions can be triggered. If work on live equipment must be conducted in explosion-prone areas, sparks that are created can trigger an explosion.

Only work on the equipment if you have the appropriate training and qualifications.

⚠ Caution

The device can be damaged if it is not cleaned as specified in the operating manual. Only clean the device as specified in the operating manual.

- Only clean the device with a slightly damp cloth!

⚠ Danger

The gas chromatograph RGC 7 must only be used as intended! (Chapter 3 *Gas chromatograph RGC 7* and 3.9 *Area of application*).

⚠ Danger

Prevent use of the gas chromatograph RGC 7 as a potential climbing aid or use of attachments of the RGC 7 as potential handles!

1.2.5 Qualification of personnel

In general, the following is recommended for all persons working with or on the gas chromatograph RGC 7:

- Training / education for work in explosion-prone areas.
- The capacity to be able to correctly estimate dangers and risks when working with the gas chromatograph RGC 7 and all connected devices. Possible dangers include components that are under pressure and consequences of incorrect installation.
- Recognition of dangers that can arise from the flow medium that is used.
- Training / education by RMG for work with gas measuring devices.
- Education / instruction in all national standards and directives to be complied with for the work to be carried out on the RGC 7-C analytical computer.

1.2.6 Risk assessment and minimization

According to assessment by qualified employees of RMG, the gas chromatograph RGC 7 is subject to risks during its use. Risks can arise due to high pressures and occasionally due to pressures that are too low. Work outside of the permissible temperature range can also lead to dangers. Impermissible current and voltage

values can trigger explosions in explosion-prone areas. The risk assessment requires an emptying and ventilation of the pipeline for connection of a RGC 7. Then and only then is it assured that there is not an explosion-prone gas mixture in the pipeline. Naturally, work must only be carried out by trained personnel (see *chapter 1.2.5 Qualification of personnel*), who are also trained to recognize suitable tools and use them exclusively. These risks were summarized alongside development and measures were taken to minimize these risks.

Measures for risk minimization:

- The maximum operating pressure and the permissible temperature range are specified on the type plate of the device. Operation of the device is only permitted within these specified ranges.

 Danger
 Work in explosion-prone areas

The following applies for work in explosion-prone areas (all zones):

- Only tools that are approved for Ex Zone 1 are permitted for maintenance and repair tasks. Components can be damaged if you do not use suitable tools.

The explosion protection is lost.

- Otherwise, work must only be carried out when there is not an explosive atmosphere.
- The risk of ignition due to impact or friction must be avoided.
- The wiring from and installation of the gas chromatograph RGC 7 in explosion-prone areas must only be carried out by trained personnel in accordance with EN60079-14 and in observance of national regulations.
- Qualified persons must satisfy the definitions in accordance with DIN EN 0105 or IEC 364 or directly comparable standards.
- Only trained and instructed personnel are permitted. Work on the measuring system must only be carried out from qualified persons and inspected by responsible qualified supervisors.
- Qualified persons have been authorized by the person responsible for safety of personnel to carrying out such work on the basis of their training, experience or instruction and familiarity with applicable standards, provisions, accident prevention regulations and system conditions. It is essential that these persons are able to recognize and avoid potential dangers in good time.

1.2.7 Applicability of the manual

This manual describes the gas chromatograph RGC 7. The gas chromatograph RGC 7 is only part of a complete system. The manuals of the other components of the system must be observed. If you find contradictory instructions, contact RMG and/or the manufacturers of the other components.

<p>⚠ Caution</p>
<p>Ensure that the power data of the current connection matches the specifications on the type plate. Observe any applicable national regulations in the country of use. Use cables that are appropriate for the cable fittings (see chapter 4.1. <i>Electrical connections</i>).</p>

Danger during operation

Observe the specifications of the system manufacturer and/or system operator.

Dangers of operation in EX areas

<p>⚠ Danger</p>
<ul style="list-style-type: none"> • Only use the gas chromatograph RGC 7 in its original condition.

- Only operate the gas chromatograph RGC 7 in fault-free and complete condition. If you make technical changes to the device, safe operation can no longer be guaranteed.
- When connecting additional measuring components or additional equipment in explosion-prone areas, ensure that the appropriate explosion protection is provided for these components.
- They are intrinsically safe devices for which galvanic isolation must be provided with connection of these devices.

The gas chromatograph RGC 7 is permitted for operation in Ex Protection Zone 1, but only within the permissible temperature range (*Appendix 1: Technical data*).

Responsibility of the operator

As the operator, you must ensure that only adequately qualified personnel work on the device. Ensure that all employees who work with the device have read and understood this manual. You are also obligated to train personnel regularly and inform them of the dangers. Ensure that all work on the device is carried out ex-

clusively by qualified persons and inspected by responsible qualified supervisors. The responsibilities for installation, operation, fault rectification, maintenance and cleaning must be clearly regulated. Instruct your personnel with regard to the risks involved with working with the device.

Suitable personal protective equipment that you, as the operator, must provide must be used for work on the RGC 7. This also applies even though all sharp edges have been removed on the device as far as possible.

1.2.8 Transport

Warning

The RGC 7 is a highly technical, quality device with glass tubes and delicate connections that partially contain flammable, explosive gases.

Therefore, any transport of the chromatograph must be carried out carefully and cautiously!

The device is packaged specific to the transport requirements for each customer. Ensure safe packaging that absorbs light impact and vibrations is used for any further transport. Nevertheless, inform the transport company that all types of impact and vibrations should be avoided during transport.

The following applies especially for transport:

- Impact and vibrations must be avoided.
- Protect the RGC 7 from moisture.
- Transport must only take place with the device lying on its back.
- Transport the RGC 7 secured on a pallet with wedges and tensioning belts, secured against movement and toppling over.
- If you suspect that transport has taken place incorrectly or that damage has occurred during transport, please contact the RMG service department immediately.

Danger

Risk of injury during transport

- Only use support and frame elements to lift the RGC 7.
- Please observe the relevant permissible loads for the lifting equipment (see chapter *Appendix 1: Technical data*).
- Prior to lifting, ensure that the load is securely fastened.
- Do not stand under suspended loads.
- The device can slip, topple over or fall down when being lifted and set down. The device can fall over if the bearing capacity of the lifting equipment is disregarded. There is a risk of severe injury for nearby persons.
- If the device is delivered on a Euro pallet, the device can be transported on the pallet using a pallet truck or forklift.

1.2.9 Scope of delivery

The scope of delivery can differ depending on the optional orders. "Normally" the following is included in the scope of delivery (of the pure RGC 7's):

Part	Quantity
Measuring unit RGC 7-M	1
Analysis computer RGC 7-C	1
Manual of measuring unit	1
Manual of analysis computer	1
...	...

1.2.10 Disposal of packaging material

Dispose of the material in an environmentally friendly manner in accordance with national standards and directives.

1.2.11 Storage

Avoid extended periods of storage. The RGC 7 is a high-precision measuring device that should not be stored for an extended time. A new factory calibration may be necessary after an extended period of storage (longer than 4 weeks). Inspect the gas chromatograph RGC 7 for damage and correct function after storage. Contact the RMG service department to arrange for inspection of the device after a storage period of longer than one year. For this purpose, send the device to RMG.

However, if storage is necessary, the following must be observed:

- The RGC 7 must be positioned upright after it has been unloaded.
- The RGC 7 must be secured against movement and tipping over.
- *Storage in an air-conditioned and dry environment is required due to the sensitivity to moisture.*
- All supply and discharge lines for gas must be sealed during storage (condition as delivered). If applicable, seal the lines with sealing plugs or dummy plugs.
- Installation must be carried out by qualified personnel only.
- If storage times of longer than 4 weeks are necessary, a permanent carrier gas flush must be provided.
- *An alternative storage is described in chapter 1.2 Interruption of the carrier gas supply.*
- Any form of improper storage can result in damage and necessitate a new factory calibration.

1.3 Explosion-proof design

1.3.1 General information

The process gas chromatograph RGC 7 in Ex version is an explosion-proof , electrical device with ignition protection type "pressure-proof enclosure" with connection housing of the ignition protection type "elevated safety".

Code:  II 2G Ex db eb IIB+ H2 T4 Gb

The device conforms to the requirements of Directive 94/9/EC.

Danger

The RGC 7 is permitted for installation in explosion-prone areas in Zone 1 that are endangered by gas and vapor group IIB+H₂ and temperature class T4.

The applicable regulations and provisions must be observed for installation and operation. The device is approved for operation in explosion-prone areas. The permissible electrical data and specifications for the temperature range are listed in *Appendix 1: Technical data*.

⚠ Caution

The device must be protected from direct weather influences.

1.3.2 Pressure-proof housing

15

⚠ Danger

The pressure-proof housing has no interlocking switch. Before opening the housing, ensure that the voltage has been switched off and observe a wait time of one minute.

(See information on the type plate)

1.3.3 Connection housing with elevated safety**⚠ Danger**

Ensure the correct voltage supply for electrical connection of the device (see specifications on the type plate).

⚠ Danger

Only certified cable connections with a male thread of M20 x 1.5 are permitted for use. The cable diameter of the supply lines must lie within the clamping range of the cable gland.

Unused openings for cable input must be sealed with shockproof sealing plugs secured from independently loosening and turning.

When sealing, it must be ensured that the seals remain effective in order to maintain the IP 65 protection rating.

2 Brief instructions

This chapter does not replace the rest of the operating manual. It only provides a brief abstract of the necessary steps to commission the device.

Danger

This chapter is only intended for experienced users!

It does not replace all safety instructions that are primarily listed in the first part of the manual but can also be found in the remaining chapters.

Moreover, use of this chapter "Brief instructions" requires that the experienced user is familiar with all these safety instructions and implements them when working with the device.

RMG rejects liability for any damage to the device or other connected devices if a user disregards even one of the safety notices in the overall manual because of this chapter "Brief instructions". This also applies to safety instructions to which reference was only made in this manual but were not explicitly listed.

2.1 Mechanical connection

The supply lines for connections A - M (*Figure 4: Gas chromatograph RGC 7*) are designed as 1/8" pipelines with a clamping ring screw connection. Appropriate particle filters are arranged upstream from the analytical device. The lines should be stainless steel and free from soiling, grease, solvents, etc.

The gases must be connected to the process gas in compliance with the rules for working with pure gases (VDI 3490 page 3, Dec. 1980).

A connection with 12 mm clamping ring is provided for the exhaust pipe.

Carrier gas connection

The connection of the carrier gas according to the aforementioned guidelines should take place with the ball valve closed first.

It must be ensured that a pressure of 4.5 bar is provided.

After connection, the supply lines must be flushed by opening the clamping ring screw connections on the inlet filters.

The voltage supply to the measuring unit can be re-established after the ball valve is opened and a wait time of **at least 15 min** is observed.

Monitoring of the carrier gas pressure now takes place with the internal pressure transducer and analytical computer. The pressure at the analytical computer can be read on the "Status" screen and fine adjustments can be made when checking the display value. Max. two carrier gas pressures are monitored. Carrier gas pressure I is the carrier gas pressure in column module 1 and 2 and carrier gas II in column module 4.

Connection values: 4,5 barhp ($\pm 5\%$)

Measuring gas (1 and 2) / Calibration gas / Reference gas

Connection of these gases must take place in the same manner as connection of the carrier gas.

The input pressure should line in the range between 1.5 – 3 barhp.

The work pressure of the measuring unit is set to 1 bar. The inlet pressure is regulated so that the working pressure is 1 bar with a tolerance of $\pm 10\%$ at the measuring unit. This pressure is monitored in the RGC7.

The pressure monitoring takes place with an integrated pressure transducer in a manner that is similar to that of the carrier gas. The measurements are also available at the bottom of the "Status" screen of the analytical computer. For pressure adjustment of the analysis gas input, the measured input pressure can be read on the RGC 7-C (marked in green) and also the pressure of the streams which have not been measured (marked in blue). Each inlet has its own pressure detector before the gases reach the measuring unit.

Column supply pressure and column temperature

If the column pressure and the column temperature are not correct, the meter goes into the "not ready" status and no measurement is taken. No error message is generated.

Further process

The "Normal Calib." operating mode must be selected after compensation of the input pressures. The chromatograph performs a calibration cycle consisting of several calibration runs.

The RGC 7 automatically switches to "Autorun" mode after successful calibration.

Please read chapter 1.2 *Interruption of the carrier gas supply* for details about interrupting the carrier gas supply.

2.2 Electrical connection

18

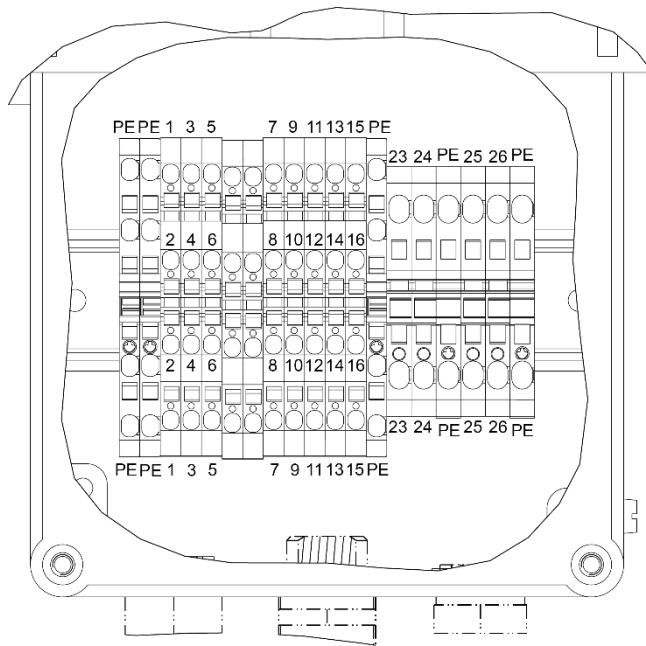

Figure 1: Electrical compartment

Clamping ranges of cable screw connections (permissible cable diameter):

Quantity	Inner casing	Outer casing
Ex-RGC 7		
1	3.1 – 8.0 mm	–
1	8.7 mm	6.1 – 13.1 mm
2	6.1 – 11.7 mm	

You can find the recommended cable types, also for earthing in *Chapter 4.1 Electrical connections*.

Terminal assignment:

Measuring unit	Signal	RGC 7-C
PE	GND	
PE	GND	
1		n.c.
2		n.c.
3		n.c.
4		n.c.
5	TxD+	Ethernet
6	TxD-	Ethernet
–	–	–
–	–	–
7	RxD+	Ethernet
8	RxD-	Ethernet
9	++	PT 100 (environment)
10	+	
11	-	
12	--	
13		n.c.
14		n.c.
15		n.c.
16		n.c.
PE	GND	
23	+24 V	Heater
24	-24 V	
PE	GND	
25	+24 V	Measuring unit
26	-24 V	
PE	GND	

2.3 Commissioning

Commissioning normally takes place together with the controller. For this purpose, read the manual of the RGC 7-C.

As a rule, commissioning should be performed according to the following steps:

1. Connect the outflow line and the bypass outflow line
2. Pipe the carrier gas cylinder, calibration gas cylinder and sample gas line to the RGC 7-M (see chapter Mechanical connections).
3. Flush the carrier gas line and the calibration gas lines.
4. Check the gas lines for leaks.
5. Connect RGC 7-M and RGC 7-C to 24 V DC.
6. Connection of the measuring unit with the controller via LAN 1.
If the distance between the measuring station and the controller is greater than 50 meters, a VDSL modem must be connected.
7. Enter the setpoint values of the calibration gas in the controller.
8. Execute the automatic baking out function by starting the function in the controller according to the instructions. Duration → 12 hours
9. Perform normal calibration and evaluate results. Here, special attention must be paid to the response factor and retention time deviation from the factory calibration. If everything is correct, a basic calibration should be started for the market launch.
10. Select the "BASIC CALIBRATION" operating mode in the RGC 7-C under 01 RGC7-C mode of option 1.0.1.

3 Gas chromatograph RGC 7

The process gas chromatograph RGC 7 of RMG analyzes natural gas and biogas and determines the quantities of individual components from which the energy content, compressibility factor and other parameters can be calculated. The RGC 7-C analysis computer used for this purpose serves as the evaluation unit and control computer for the analysis process. Here the measurement results are stored and are ready for output. The RGC 7-M is always operated together with the RGC 7-C.

3.1 Type designation

The variants of the RGC 7 differ depending on the application. The designation RGC 7 is used as a collective term in this manual. If differentiation must be made between the variants, they are listed separately.

RGC 704

This type enables determination of additional gas components in "normal" natural gas.

It works with 3 column modules (1, 2 and 4). With the column modules 1 and 2, it can determine the same gas components as the RGC 711; with the 3rd column module 4, it can also determine hydrogen (H₂), oxygen (O₂), helium (He) and nitrogen (N₂).

Table 1 below summarizes the properties again.

TYPE	Area of application	Channels (column modules)	Measured components *
RGC 704	Natural gas extended, with helium measurement and increased measuring range for H ₂	1 (helium carrier gas) 2 (helium carrier gas) 4 (argon carrier gas)	C ₁ , CO ₂ , C ₂ C ₃ to C ₆₊ He, H ₂ , O ₂ , N ₂

* The chronological sequence of the components corresponds to the sequence of the list.

Table 1

3.2 Mode of operation

A gas sample is taken from the process line with a sampling probe. Filtration and pressure reduction take place in an inlet pressure regulating unit before the sample is delivered to the measuring element. An optional gas dryer can be provided. *Figure 2: Gas chromatograph block diagram* shows the typical layout of the chromatograph in a block diagram.

21

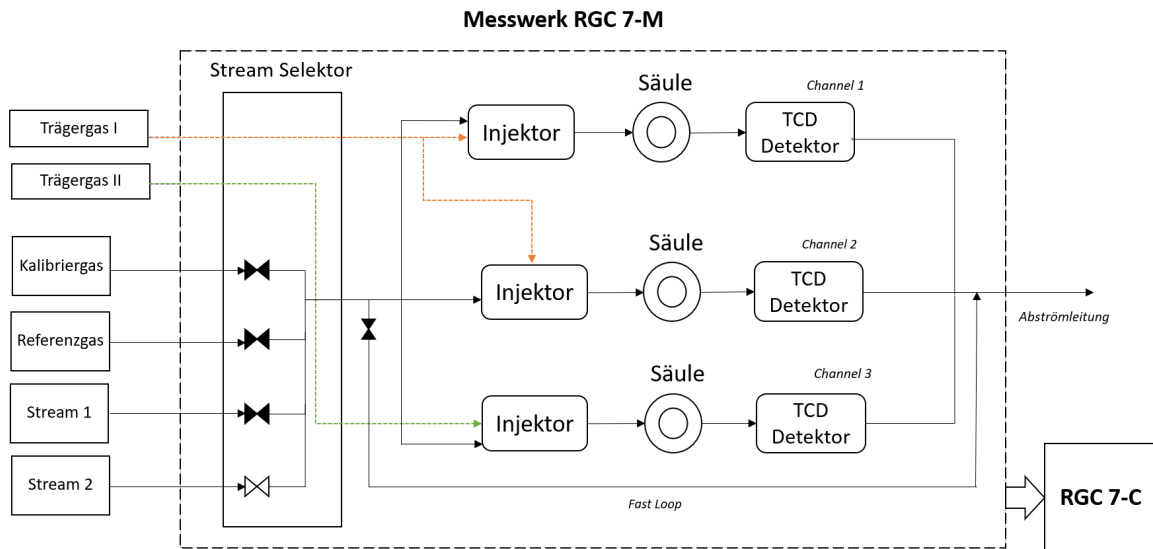

Figure 2: Gas chromatograph block diagram

One of the four inputs (sample gas 1+2, reference gas and calibration gas) is switched by the stream selector inside the analyser. A precisely defined quantity of the gas to be analyzed is supplied to the separating columns by means of the injector. This quantity is delivered through the separating columns with a carrier gas, which represents a so-called mobile phase.

The separation of the gas mixture is based on the interaction between the stationary phase, the coating and/or filling of columns and the components of the gas that flows past. With adsorption and a strong interaction of the individual components with the stationary phase, the individual components are selectively delayed in their passage in the stationary phase, moving at different speeds through the column. As a result, all the components arrive at the end of the column at different times.

A thermal conductivity detector detects the emergence of the components. Therefore, a signal varying in length and height, a so-called peak, is generated for each component. The surface under the signal curve is a measurement for the corresponding amount of substance.

In the measuring unit, helium is used as the carrier gas and, if column module 4 is installed, argon is also used. Three columns that operate in parallel are used for the separation.

The further evaluation of the surface shares takes place in the analytical computer RGC 7-C.

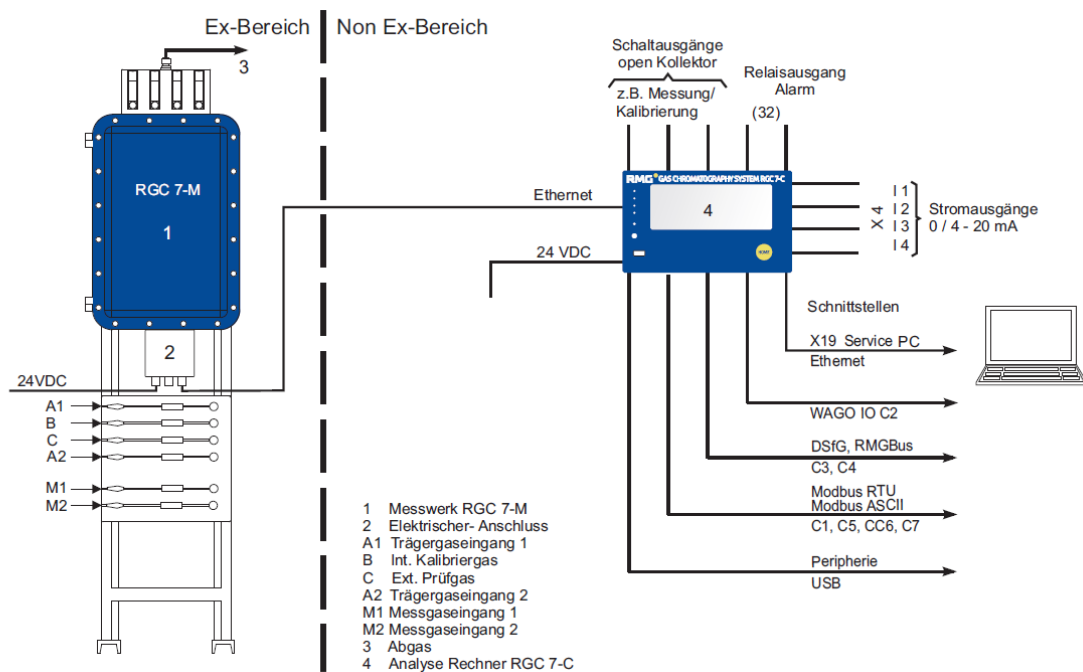

- | | | | |
|----|--------------------------|----|------------------------------------|
| 1. | Measuring unit RGC 7-M | A2 | Carrier gas input argon |
| 2. | Electrical connection | M1 | Measurement gas input 1 |
| A1 | Carrier gas input helium | M2 | Measurement gas input 2 (optional) |
| B | Calibration gas input | 3 | Bypass and exhaust gas |
| C | Reference gas input | 4 | Analytical computer RGC 7-C |

Figure 3: Separation of Ex zones

The analytical computer RGC 7-C is the controller for the process gas chromatograph RGC 7 and controls the analysis process in the measuring unit RGC 7-M and its analysis module. In normal operation, an analysis begins as soon as the preceding analysis is finished, wherein each analysis lasts about 45-60 seconds, depending on the variant.

The series of analyses proceeds without interruption by automatic calibration. A calibration normally comprises 10 calibration gas analyses (or can be adjusted for more) and lasts about 15 minutes. The number of calibration runs is specified in the approval.

The PTB approval specifies that this calibration must be repeated once per day (calibration interval = 1 day), but other intervals can be adjusted, too.

The RGC 7 can be designed as a **single stream unit** for analysis of the gas from one extraction point or as a **multi-stream unit** for up to 2 extraction points.

Note

With multi-stream units, the measured gases change with each analysis in the standard setting.

If different measuring gases are measured in a multi-stream unit, the setting should be changed so that multiple measurements of the same gas take place in succession. This reduced a potential influence of mixture.

Please observe the corresponding legal calibration specifications for measurements directed by the calibration authority.

3.3 Configuration of the measuring unit

Figure 4: Gas chromatograph RGC 7 shows the measuring element unit in its Ex d housing. The unit can be broken down into four primary components.

- The electrical connection socket (2) with appropriate connections for the analytical computer RGC 7-C. (Data exchange, voltage supply).
- A pressure-proof encapsulated unit (1) containing parts of the voltage supply and valve control.
- The gas distribution with carrier gas inputs A1 and A2 and inputs for the various gas streams (B, C, M1, ...).

These inputs are connected to the chromatograph via a "Double Block and Bleed" valve assembly. The valve circuit is integrated in the measuring unit. The analytical computer RGC 7-C controls the switching.

Furthermore, four pressure transducers (measuring gas 1+2, reference gas, calibration gas) are integrated to monitor the analysis gas pressure.

The carrier gas pressure is measured in the measuring unit and also controlled in the RGC 7-C analysis computer.

- The actual chromatograph is located in a pressure-proof encapsulated housing (1).

This compact unit comprises the separating columns, heating, injectors, detectors, pressure regulation, data recording hardware and communication hardware. The housing is heated in order to maintain the necessary internal temperature.

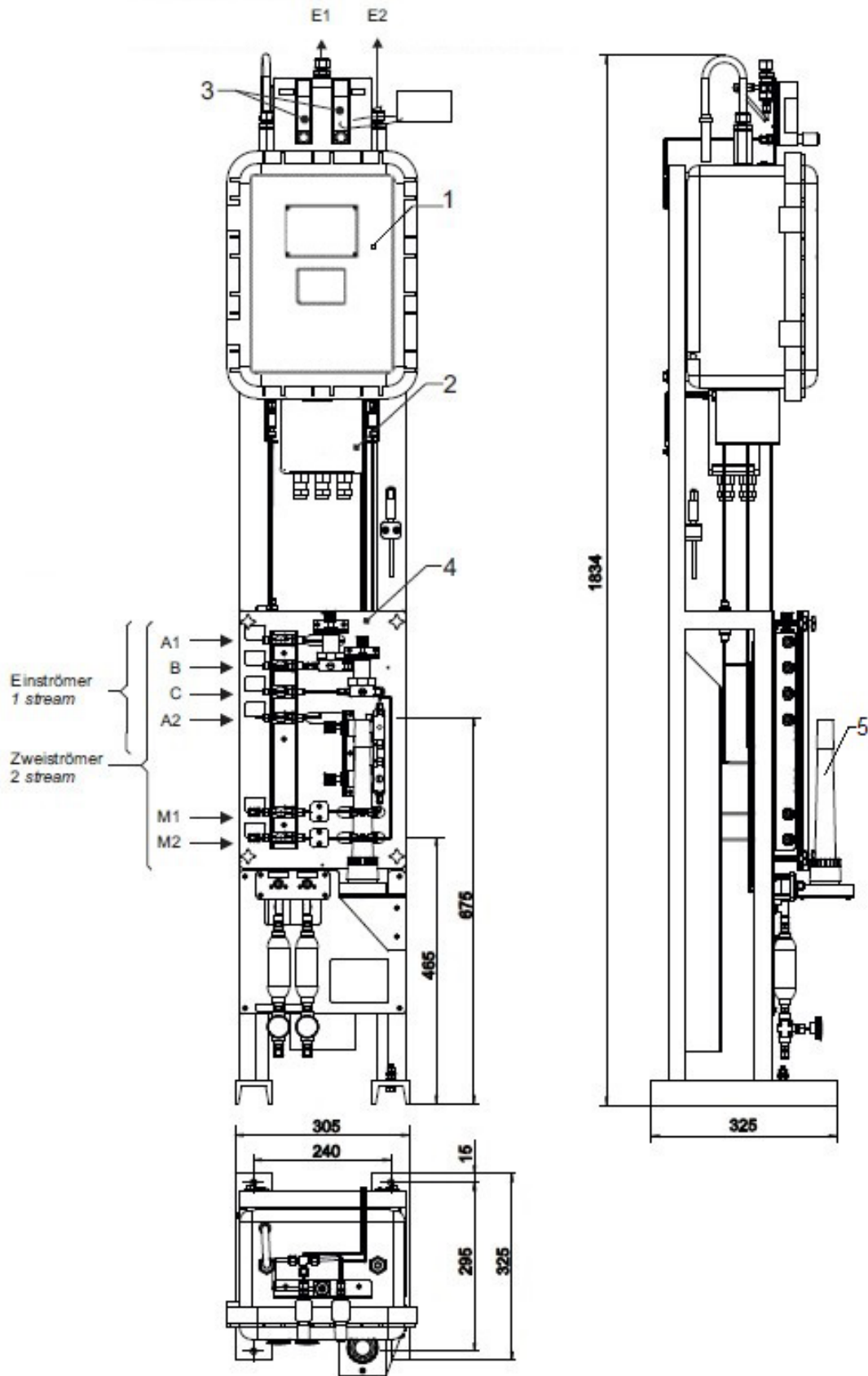

1. Chromatograph, type 03550 with valve control pressure-tight encapsulated
 2. Ex(e) connection socket
 3. Variable area flowmeter for bypass and sample gases
 4. Gas input module with filter
(Gas input either on the left side or on the right side)
 5. Molecular sieve filter
 - E1. Outflow line bypass
 - E2. Outflow line measuring gas
 - A1. Gas input carrier gas (Input pressure 4,5 bar)
 - B. Gas input calibration gas (Input pressure 1,5-3 bar)
 - C. Gas input ext. Test gas (Input pressure 1,5-3 bar)
 - A2. Gas input carrier gas 2 opt. (Input pressure 4,5 bar)
 - M1 Gas input measuring gas 1 (Input pressure 1,5-3 bar)
 - M2 Gas input measuring gas 2 opt. (Input pressure 1,5-3 bar)
- } Single stream unit
} Double stream unit
- Fastening hole $\varnothing 11 \times 4$
 - Fasten the device to the wall with the enclosed mounting brackets
 - Supply lines for ports A, B, C:
1/8" tube on compression fitting
 - Supply lines for M1-2:
6 mm tube on compression fitting
 - Supply lines for connections E1, E2:
12 mm tube on compression fitting
 - Total weight approx. 60 kg

Figure 4: Gas chromatograph RGC 7

3.4 Modularity of the measuring unit system

The arrangement of the measuring unit can be modular. In most cases, the two main components (analysis unit (measuring unit) & gas input module) are arranged on a common rack as in Figure 6: Gas chromatograph RGC 7 shown. Alternatively, however, the main components can each be mounted on back panels, which can then be mounted on the wall or arranged side by side on a rack.

3.5 Gas distribution

The purpose of the gas distribution is two gas streams to the analyzer and to supply the carrier gas.

In order to avoid contamination of the selected gas stream due to potential leakage of the valves, a so-called "Double Block and Bleed" arrangement of valves was selected.

Figure 5: Gas distribution (principle diagram) shows a corresponding arrangement in which gas stream 1 is selected.

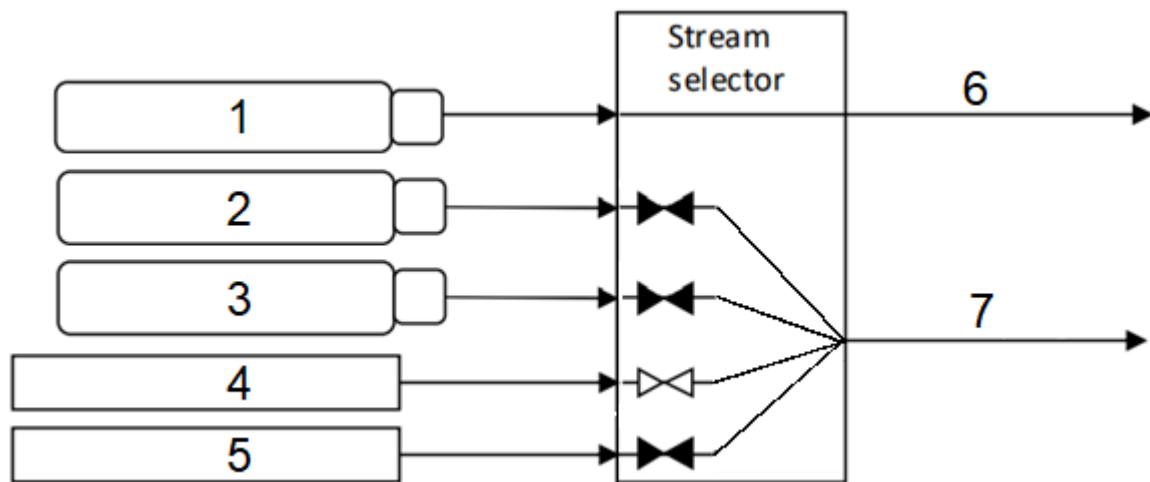

- | | | | |
|---|------------------------|---|---------------|
| 1 | Carrier gas bottle | 6 | Carrier gas |
| 2 | Calibration gas bottle | 7 | Measuring gas |
| 3 | Reference gas bottle | | |
| 4 | Measuring gas 1 | | |
| 5 | Measuring gas 2 | | |

Figure 5: Gas distribution (principle diagram)

3.6 Gas chromatograph

Figure 6: Design of the analysis unit shows the layout of the analysis unit located in the pressure-proof housing (Pos. 6).

28

The analysis module is divided into two main units:

Column cassette (Cartridge) - Support with up to three column modules
A column module comprises an injector, a reference and measurement column, heat conductivity detectors, column heating, injector heating and a back flush unit.

Basic modules (Host) - pneumatic components and gas distribution as well as electronic control elements

The host consists of electronics with computing power, pneumatic components and a gas distribution manifold. Via dedicated firmware, it handles control of the microchips, column heaters, sample injectors, and readout of thermal conductivity detector (TCD) signals. It also controls valves to route incoming gases to the cassette and provides electrical connections to the cassette.

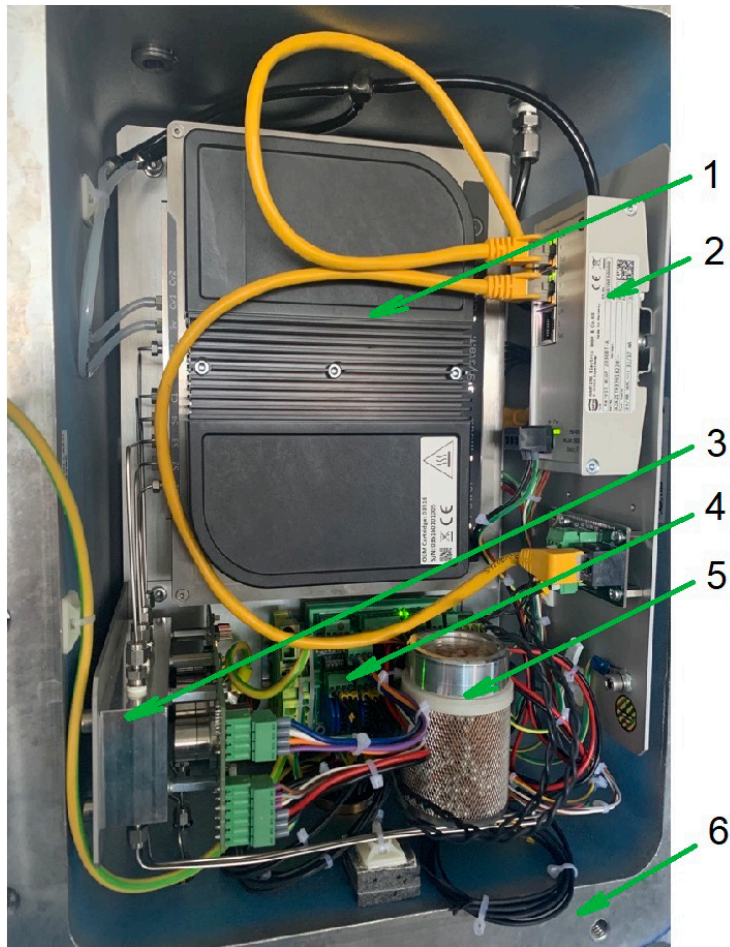

- 1 Analysis module
- 2 VDSL Modem (Option)
- 3 Sensor block (measurement of the measuring gas pressure)
- 4 Filter PCB
- 5 Dry agent cartridge
- 6 Ex d housing

Figure 6: Design of the analysis unit

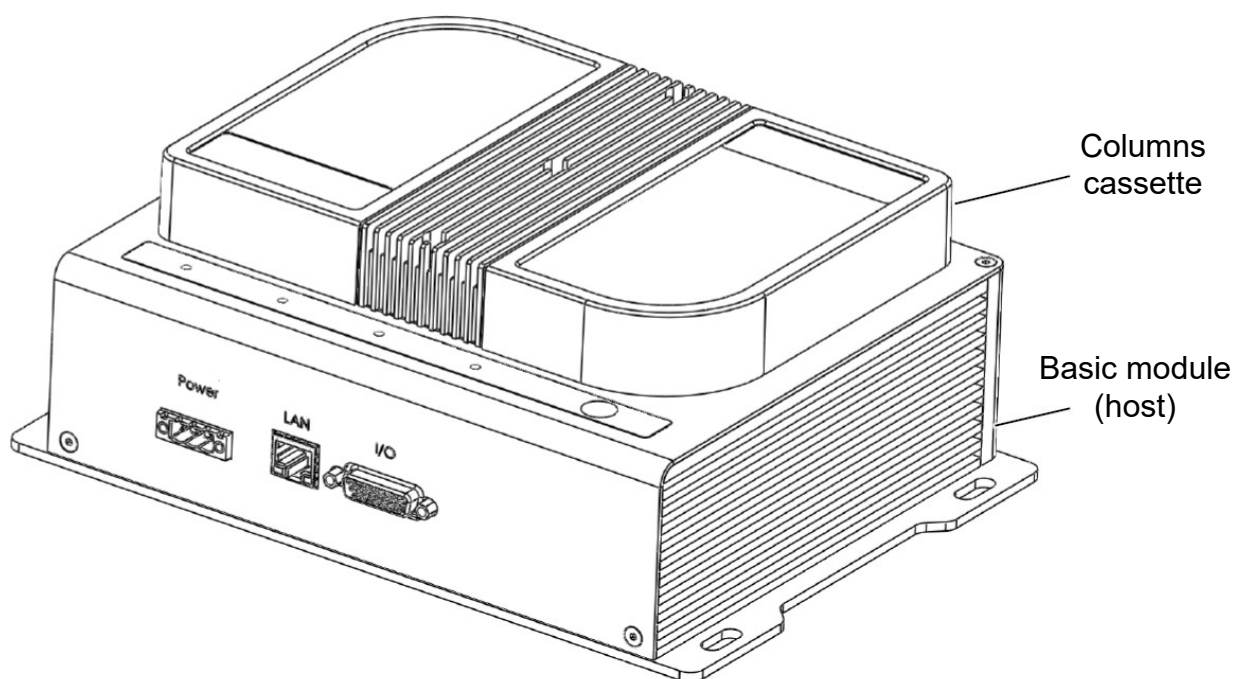

Figure 7: Function blocks of the analysis module

3.7 Analysis process

3.7.1 Detector

The thermal conductivity detector (TCD) used, is a universal detector for gas chromatography. This detector detects changes in the thermal conductivity of the column effluent and compares it to a reference flow of carrier gas. The main advantages of TCD are its simplicity, its wide dynamic range, its general response to both organic and inorganic components, and its non-destructive nature.

3.7.2 Injection

In principle, both the sample gas and the carrier gas flow continuously into the GC and through the chips of all GC channels. Inside these chips is a small chamber, the sample loop, through which the sample gas flows continuously. During injection, this sample loop is sealed, pressurized with the carrier gas, and then relieved toward the columns. The advantage of this principle is that the sample gas is injected at a controlled carrier gas pressure and thus there is no measurement error due to pressure fluctuations. The amount of sample injected depends on the injection time. A schematic diagram of the microinjector is shown in the following figure.

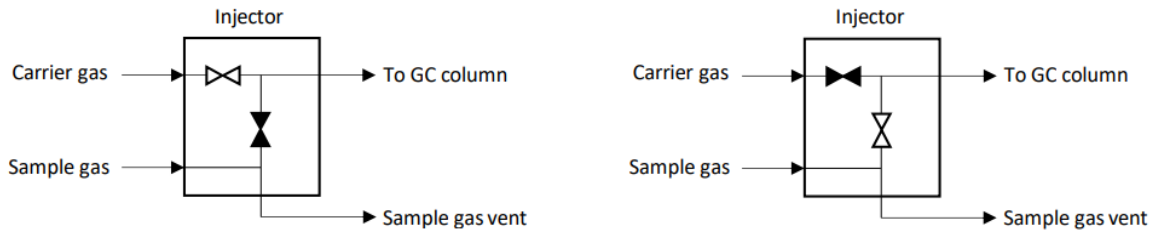

Figure 8: Illustration of the microinjector. Left: no injection, right: during injection of the column module.

3.7.3 Back-Flush configuration

The RGC 7 is operated in a back-flush configuration for all columns. In this case, a precolumn is added before the analytical column. After a defined time following injection, the flow in the precolumn is reversed and flushed back to a second detector (TCD BF). At the same time, the peaks that have already left the precolumn are passed through the analytical column to the first detector (TCD FF). There are two purposes for this configuration:

1. The lifetime of the analytical column is increased as the entry of contaminating/reactive components into the column is prevented.
2. By using a second detector, both fore-flush and back-flush chromatograms run in parallel, reducing the overall analysis time, which is discussed in more detail below.

At the start of an analysis, the carrier gas directs the sample in the so-called Fore-Flush (FF) state to the precolumn and to the analytical column, as shown in the figure below. The injected sample is separated in the precolumn, and the separated components can enter the analytical column.

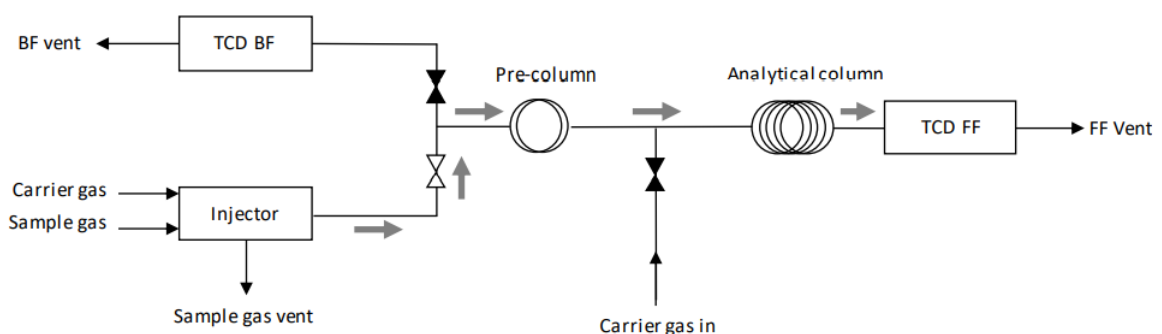

Figure 9: Fore-flush (FF) flow diagram representation - the gas flows only from left to right.

After a certain time, the flow is switched to the Back-Flush (BF) state. The 'Carrier Gas In' valve between the columns is opened and the gas flows backwards in the

precolumn and simultaneously the gas flows backwards in the precolumn and further forwards in the analytical column. The reverse flow of the precolumn is directed to the backflush TCD (TCD BF) and the backflush valve (BF vent).

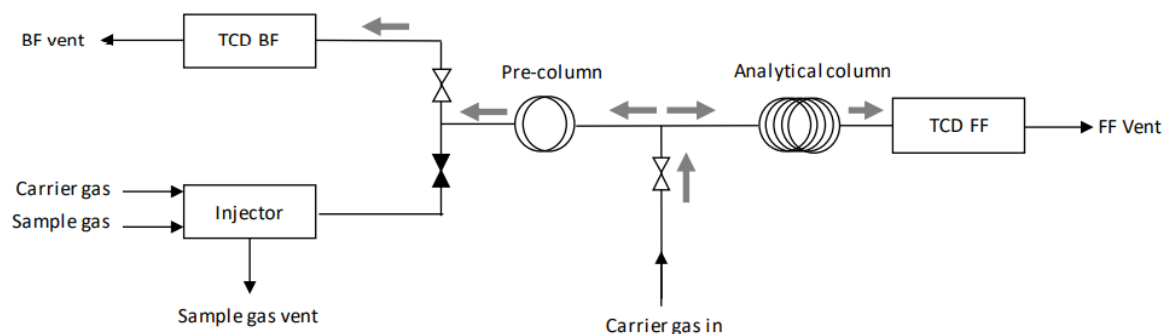

Figure 10: Illustration of the back-flush (BF) flow diagram - .
at the precolumn the gas flows backwards to the TCD BF detector and at the analytical column the gas continues to flow forward to the TCD FF detector.

In this way, unwanted components that move slowly through the precolumn are prevented from entering the analytical column; in principle, the precolumn back-flush thus acts like a filter. Note that separated sample components in the pre-column will regroup during backflushing and consequently result in a single so-called backflush peak at the backflush detector.

3.8 The column module

The column module generally consists of 3 components: Injector, column oven and detector, which are schematically shown in the figure below. Figure 10: Flushing (default position).

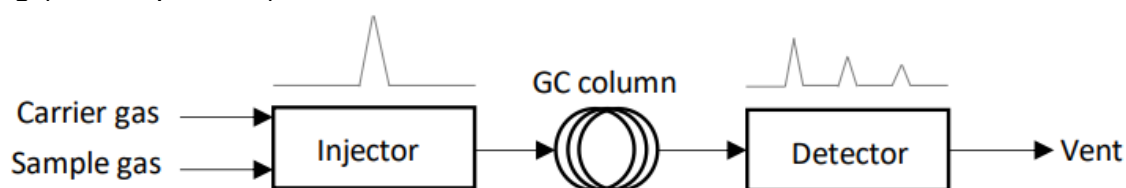

Figure 11: Schematic representation of the column module with injector, GC column and detector

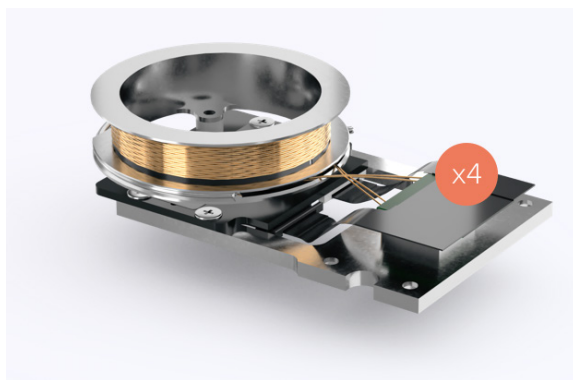

Figure 12: Column module (picture)

The **column modules** each contain **injectors**, **columns** and **thermal conductivity detectors TCD**

3.9 Area of application

The RGC 7 is normally operated in an Ex d housing in Ex Zone 1.

Safety classification:

II 2G Ex db eb IIB+ H2 T4 Gb

3.10 Data recording and evaluation

The essential points of data recording and evaluation are outlined in the separate manual RGC7-C. Only a few points that are relevant for the gas chromatograph are covered here.

3.10.1 Basic principles of the analysis

The basic factory setting assures good separation of the individual gas components when passing through the columns. The corresponding parameter set is identified as a **method**. Part of these settings is displayed and checked via the analytical computer. Physical bases of the analysis process that have a direct influence on the analysis result are defined in the **method**:

- The Column temperatures

The column temperatures have a **direct** influence on the separating performance and analysis times. The temperature of the columns is therefore kept constant and displayed on the analytical computer.

- The Running time

The running time determines the time period for which the data recording and evaluation of the Temperature Conductivity Detector (TCD) signals take place.

- Column pressure

The column pressure is a parameter that influences the separation efficiency of each column and is defined in the method at the factory. This pressure is also shown by the analytical computer.

3.11 Used gases and gas consumption

3.11.1 Carrier gas

The used helium and argon carrier gases must correspond to at least class 5.0 (99.999%). The following inlet pressure must be correctly adjusted for proper function of the measuring element:

$$p_T = 4.5 \text{ bar } (\pm 5\%)$$

Pressure monitoring takes place with a pressure transducer arranged in the gas distribution. The analytical computer monitors the output signal of the pressure transducer.

The total carrier gas consumption varies as follows depending on the column pressure and variant:

$$Q_T = 1.6 \text{ NI/h} - 4.1 \text{ NI/h}$$

Note

Since helium, in particular, escapes through the smallest leaks, careful sealing and inspection of the system is very important.

3.11.2 Internal calibration gas

The following composition is used for the internal calibration gas:

Component	Concentration (mol%)
	Natural gas extended RGC 704 (Typ13K)
Nitrogen	4.00
Methane	87.45
Carbon dioxide	1.50
Ethane	4.00
Propane	1.00
Iso-butane	0.20
n-butane	0.20
neo-pentane	0.05
iso-pentane	0.05
n-pentane	0.05
n-hexane	0.05
Oxygen	0.50
Hydrogen	1.00

35

Note

Calibration gases must never cool down below the permissible minimum temperature specified on the corresponding certificate.

The usability of calibration gases is subject to a time limit; the expiration date is also specified on the certificate.

The inlet pressure at the RGC 7-M for the calibration gas is 1.5 - 3 barhp.

In the measuring unit, the calibration gas pressure is regulated to:

$$p_e = 1.0 \text{ bar (internal)}$$

This value is monitored and displayed in the controller.

It must be specified before the basic calibration. Changes at a later time are not permitted. The permissible deviations during operation are:

$$d_{pe} = \pm 10\%$$

Permanent consumption of gas takes place during the entire calibration time. With a pressure at the inlet of the measuring unit (after pressure control) of $p_e = 1.0$ bar, the total flow rate is:

$$Q = 3 \text{ NI/h} - 5 \text{ NI/h}$$

3.11.3 Measuring gas

⚠ Caution

The probe to be analyzed must be in a gaseous aggregate state and dry. Liquid components and other impurities are not permitted.

The values specified under 3.11.1 and 3.11.2 apply for the inlet pressure and gas consumption. The working range of the modules is within the following limit values:

Component	Concentration (mol%)
	Officially calibrated metering
RGC 7	
Nitrogen	≤30,0
Methane	≥50,0
Carbon dioxide	≤20,0
Ethane	≤15,0
Propane	≤15,0
Iso-butane	≤4,0
n-butane	≤1,8
neo-pentane	≤0,1
iso-pentane	≤0,5
n-pentane	≤0,5
C6+	≤0,3
Oxygen	≤3,8
Hydrogen	≤20

Note

The limit values on the type plate apply in calibrated operation.

4 Connection and commissioning

4.1 Electrical connections

⚠ Caution

The voltage supply of the measuring element must not be connected until the carrier gas flow has been connected and applied for at least 15 minutes!

37

The electrical connections must be made as specified in the accompanying circuit documents for both the analytical computer and the measuring element. The following connection assignment applies.

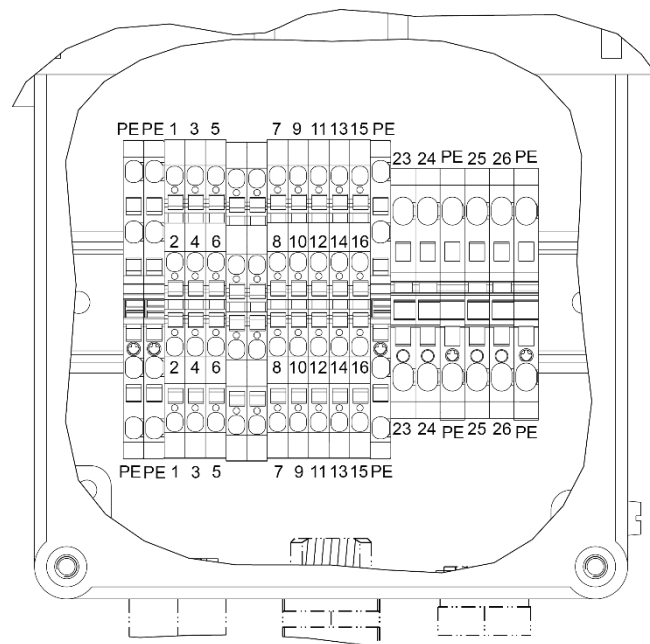

Figure 13: Connection assignment

Terminal assignment:

Measuring unit	Signal	RGC 7-C	Recommended cable type
PE	GND		
PE	GND		
1		n.c.	
2			
3		n.c.	
4			
5	TxD+	Ethernet	Herkulat, 600 A S/FTP 7 RxD+ 4 x 2 AWG23
6	TxD-		
–	–	–	–
–	–	–	–
7	RxD+	Ethernet	Herkulat, 600 A S/FTP 7 RxD+ 4 x 2 AWG23
8	RxD-		
9	++	PT 100 (environment)	
10	+		
11	-		
12	--		
13		n.c.	
14		n.c.	
15		n.c.	
16		n.c.	
PE	GND		
23	+24 V	Heater	NYY-J 3G 2.5 mm ²
24	-24 V		
PE	GND		
25	+24 V	Measuring unit X2 / 1	NYY-J 3G 2.5 mm ²
26	-24 V		
PE	GND		

 Cables with this indication must be twisted

The cable type NYY-J 3G 4 mm² should be used for the voltage supply (17-18) for distances greater than 50 m between the control cabinet and RGC.

Clamping ranges of cable screw connections (permissible cable diameter):

Quantity	Inner casing	Outer casing
Ex-RGC 7		
1	3.1 – 8.0 mm	–
1	8.7 mm	6.1 – 13.1 mm
2	6.1 – 11.7 mm	–

Note

Some parameters for specifications are set to default values after switching the analytical computer on for the first time.

These values must be checked and changed as necessary (refer to the manual for the analytical computer RGC 7-C)!

The changed values are saved and then remain available after the computer has been shut down.

4.1.1 Grounding

Most grounding is done at the factory and is therefore not described further. However, customer grounding must also be performed; the entire rack must be grounded.

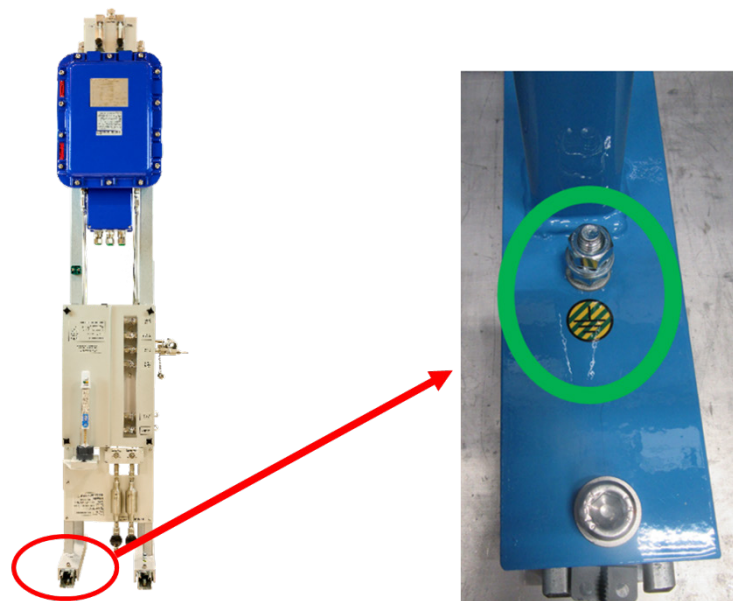

Figure 14: Grounding

Note

Please carry out the grounding at the screw provided for this purpose in the area marked in green.

The thickness of the grounding cable should be at least 4 mm².

40

4.1.2 PT100 for ambient temperature measurement

A PT 100 is installed on the frame of the RGC 7 to measure the ambient temperature and thus check the conditions required for the proper operation of the RGC 7. The PT100 cable consisting of four wires is connected to terminals 9 to 12 in the junction box (see section 4.1 Electrical connections). The temperature values supplied by the PT100 are read "digitally" by the sensor board and transmitted to the measuring unit of the RGC 7-M via the filter board. The measuring unit forwards the values to the controller via a TCP/IP connection (see *Figure 15: PT100 signal path*).

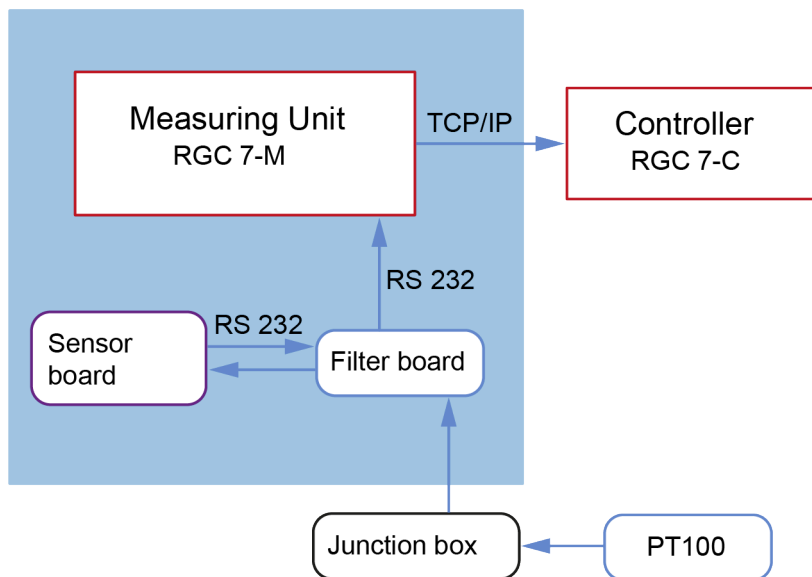

Figure 15: PT100 signal path

To be able to process the temperature values correctly, the "digital" encoder type must be selected in the Controller menu **Details** at level 15.13 Inputs and outputs, temperature 1.

For more details on the selection, please refer to the RGC 7-C operating instructions.

4.2 Gas connections

The supply lines for connections A - M (*Figure 3: Separation of Ex zones*) are designed as 1/8" pipelines with a clamping ring screw connection. Appropriate particle filters are arranged upstream from the analytical device. The connection lines to RGC 7 should be stainless steel and free from soiling, grease, solvents, etc.

41

Note

To prevent contamination with dirt or environmental air, the supply lines, must be gas-tight in the relevant pressure range.

If it is necessary to seal threads or screw connections, only use Teflon tape for this purpose.

(Of course, this does not apply for compression fitting!)

Avoid using liquid leak detecting agents.

The tightness of all connections is extremely important for a proper analysis.

The gases must be connected to the process gas chromatograph in compliance with the rules for working with pure gases (VDI 3490 page 3, Dec. 1980).

Note

It must be ensured prior to commissioning that the gases that are used correspond to the specified requirements.

The gas discharge line must have a minimum inside diameter of 4 mm. A 6 mm clamping ring connection must be provided.

⚠ Caution

No additional devices can be connected to the line.

The outflow pipes of the measuring unit must be executed separately and must not be combined! The outflow pipes of the bypass are combined.

⚠ Danger

An overpressure must not develop in the line.

4.2.1 Carrier gas connection

Note

The connection of the carrier gas according to the aforementioned guidelines should take place with the ball valve closed first.

It must be ensured that a pressure of 4.5 bar is provided.

After connection, the supply lines must be flushed by opening the clamping ring screw connections on the inlet filters.

The voltage supply to the measuring unit can be re-established after the ball valve is opened and a wait time of at least 15 min is observed.

Monitoring of the carrier gas pressure now takes place with the internal pressure transducer and analytical computer. The pressure at the analytical computer can be read on the "Status" screen and fine adjustments can be made when checking the display value.

Connection values: 4,5 bar ($\pm 5\%$)

4.2.2 Measuring gas / calibration gas / reference gas

Connection of these gases must take place in the same manner as connection of the carrier gas. The inlet pressure at the RGC 7 can be between **1,5 – 3 bar**. Subsequently, the inlet pressure for the measuring unit at the gas inlet module is regulated to $1\text{bar} \pm 10\%$. The specification of a specific inlet pressure must take place before the basic calibration of the device. If this pressure has been defined, changes are no longer permitted.

Note

The pressure must be identical for all four inputs. The permissible tolerance is $\pm 10\%$.

These pressure values can be checked in the RGC 7-C. The measurements are also available at the bottom of the "Status" screen of the analytical computer. The measured input pressure at the RGC 7-C can be read for pressure equalization of the analysis gas input. The pressure adjustment must be performed separately for each stream as well as for calibration gas and reference gas.

4.3 Column supply pressure and column temperature

The column temperatures and carrier gas pressure at the injectors can be defined with the factory calibration of the device.

The corresponding limit values can be accessed on the analytical computer by pressing the "Measuring unit" button (Manual RGC 7_AC_manual_en).

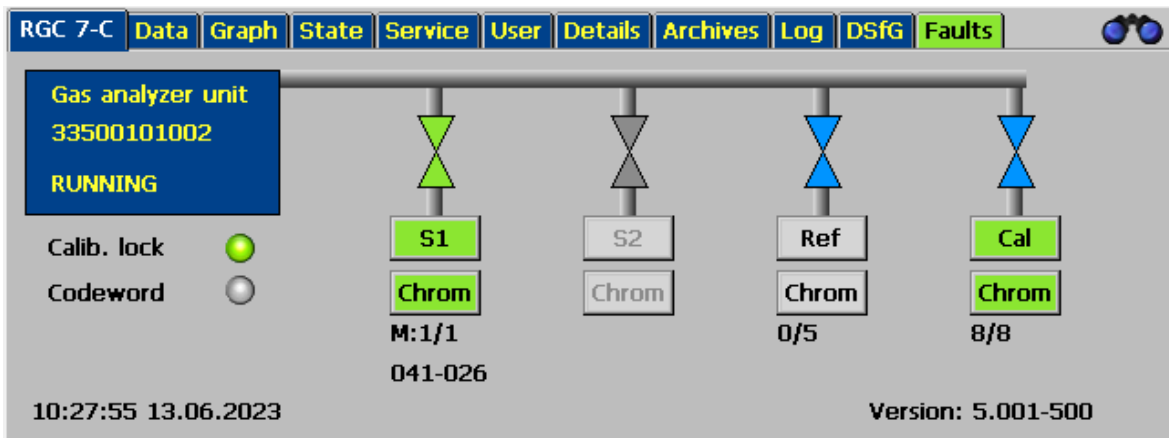

Figure 16: Start screen and status

		Channel 1	Channel 2	Channel 3	Channel 4
Instrument State					
RUNNING					
Column Temp	°C	70.00	70.00	0.00	79.99
Injector Temp	°C	119.98	119.99	0.00	119.98
Column Pressure	bar	1.00	1.70	0.00	2.25
		OK	OK	OFF	WAIT
Sample gas S1	Sample gas S2	ref. gas	cal. gas	Carrier gas 1	Carrier gas 2
0.32	0.06	0.04	1.02	4.53	4.47

Figure 17: Column temperatures and carrier gas pressure

4.4 Further process

The "Normal Calib." operating mode must be selected after compensation of the input pressures according to the description above. The chromatograph will now conduct a calibration cycle.

If the first calibration is faulty, the RGC 7 will start another calibration after a few minutes. If the second calibration is also faulty, the RGC 7 automatically switches to the operating mode "Stop".

The RGC 7 automatically switches to "Autorun" mode after successful calibration.

4.5 Interruption of the carrier gas supply

With an interruption of the carrier gas supply, e.g. during a change of the carrier gas cylinder without use of the switchover unit, the analysis must be interrupted by selecting the mode "STOP" on the analytical computer.

If the analytical computer has "STOP" status, – in other words, the running analysis was ended – all inlet valves on the gas distribution (*Figure 4: Gas chromatograph RGC 7 / A - M*) are closed. When the carrier gas pressure at the measuring unit has fallen far enough, the measuring unit goes into "Stabilising" mode. Then the measuring unit can be switched off.

If the supply with carrier gas has been ensured (regular flushing of pressure regulators and supply lines!), the inlet pressure should be checked after the measuring unit is switched on.

After the inlet valve (*Figure 4: Gas chromatograph RGC 7 / A1 and A2*) has been opened, a further check can take place on the analytical computer ("Status" screen). The device must remain in this state **for at least 15 min.**

After a waiting time of an additional 15 min, the remaining inlet valves (*Figure 4: Gas chromatograph RGC 7 / B, C and M*) can be opened again. The analytical computer must now be switched to the mode "Normal calib.". After successful calibration, the analytical computer automatically switches over to "Autorun" mode.

Note

If the voltage supply was disconnected for more than 0.5 h, an additional calibration should take place after about 1-2 h.

If error messages appear on the initial calibration or at the beginning of the analysis, it may be due to the remains of foreign gases.

These messages should be acknowledged within 2 h after operation.

If the measuring element should be decommissioned for an extended period, the device should be shut down.

For this purpose, the measuring element must first be disconnected from the voltage supply as described above. If possible, the supply of the measuring element with carrier gas should continue for the duration of the downtime by opening the inlet valve for helium after the measuring element has been shut down. If this is not possible, the exhaust gas line should be provided with a gas-tight seal with a dummy plug after shutting down the measuring element and interrupting the carrier gas supply until the time of re-commissioning. In principle, the exhaust gas lines must be sealed gas-tight if they are to be taken out of service for a longer period of time.

For a longer period of storage, the RGC 7 can be prepared by flushing the device with nitrogen (5.0) at 3 bar for at least 15 minutes at all inlets. Then all inlet valves must be closed and then the two outflow lines must also be provided with a gas-tight seal with dummy plugs.

⚠ Caution

The discharge lines must be re-connected after re-commissioning and the device must be flushed with the carrier gas (helium) for at least 15 minutes before the device is switched on again.

Note

Chapter 1.2.11 Storage provides further information about storage of the RGC 7.

Re-commissioning must then take place according to the process above.

⚠ Caution

The dummy plugs must be removed first. Otherwise an excessively high pressure is established in the measuring element!

Disregarding this can result in irreparable damage to the measuring element!

The versions with column module 4 also include a replaceable filter cartridge between the shut-off valve and housing feedthrough for the carrier gas line.

4.6 Inspection and maintenance tasks

4.6.1 General information

Note

Explosion-proof electrical control units must be maintained on a regular basis.

The time intervals for this inspection depend on the operating and environmental conditions. We recommend at least one inspection per year (e.g. in connection with the annual calibration of the RGC 7).

The following **recurrent** maintenance tasks require knowledge that is described in the further course of the manual. Therefore, please read the entire manual or search for the appropriate chapter in the table of contents.

All maintenance intervals and tasks are listed in the **accompanying** book of maintenance logs. The measures described there are prerequisite for the calibration of the device and any warranty claims.

Note

Manual, maintenance book, acceptance inspection certificate and test logs must remain accessible within the vicinity of the RGC 7 and always readily available (see also chapter 0 *Dangers during commissioning*).

All measures must be documented, particularly maintenance tasks.

⚠ Danger

If it is necessary to open a pressure-proof housing, suitable measures must be taken to assure that the housing is not exposed to an explosion-prone atmosphere.

47

⚠ Danger

Work on live equipment in explosion-prone areas is prohibited as a fundamental principle (except for intrinsically safe power circuits).

In special cases, work can also be carried out on live equipment in explosion-prone areas if it has been assured that an explosion-prone atmosphere is not present. This must only take place with approved, explosion-proof measuring devices.

⚠ Danger

If access to electrical assemblies of the analytical computer or measuring element is necessary, the following precautionary measures must be taken:

- The entire device must be disconnected from the voltage supply.
- When working with electronic assemblies, a connection between a grounded object and the body must be established.
- To interrupt the carrier gas supply, refer to *chapter 1.2 Interruption of the carrier gas supply*.

Note

Pay attention to accumulation of water in the housing, because the explosion-proof housing is only conditionally protected from water by the gap protecting against ignition sparks (IP65).

Rusted or corroded gaps must not be cleaned with grinding materials or wire brushes; chemical means must be used, such as reducing oils. Then acid-free anti-corrosive agents, such as ESSO RUST BAN 397, Mobil Oil Tecrex 39 or equivalent products must be applied to the gaps for protection.

Note

In order for the products of the RGC 7 family to comply with protection class IP65, they must be protected against the penetration of dirt and rain by connecting a gooseneck pipe or by attaching suitable piping to the outlet of the vent valve.

When setting up the unit, it must be ensured that this function is available.

! Danger

The seal for the Ex-e housing must be inspected for damage and replaced as necessary.

Check cable connections and sealing plugs for tight seating.

Damage to the housing can negate the Ex protection!

If part of the device that is essential for Ex protection is repaired, the device cannot be re-commissioned until it has been inspected by a recognized qualified expert (Chapter 1.2.5 *Qualification of personnel*).

If repairs are carried out by the manufacturer, acceptance by a qualified expert is not necessary.

4.6.2 Draining condensate from the measuring element

There is a diaphragm filter on the measuring element with a condensate collection container (*Figure 3: Separation of Ex zones*, Pos. 6, one per gas stream, optional for natural gas). From time to time it is necessary to drain condensate from the drain valves under the containers.

For this purpose, first **close the corresponding inlet valve on the measuring element** and open the respective drain valve for about 10 seconds.

! Danger

The line contains explosive gas under a line pressure of approx. 3 bar.

The interval is determined by the humidity of the measuring gas. The optimal interval is determined by initially draining the condensate in short intervals (e.g. weekly). With lower quantities of emerging condensate, the interval can be extended

until the amount of condensate is approximately half of the volume of the collecting container.

⚠ Caution
Do not open drain valves while an analysis is in progress, because this causes a pressure drop in the measuring element and disturbs the analysis. Instead, set the operating mode to "STOP" and wait for the end of the current analysis.

49

4.6.3 Changing carrier gas cylinders

An inlet pressure of 4.5 bar for the carrier gas is required for operation of the RGC 7. This value must not be undercut by more than 5%; any values below that level will trigger an alarm. Since the carrier gas also has a protective function and protects the measuring element from the penetration of oxygen, this situation should never arise!

Note
If the carrier gas pressure reports an error, measurement is not carried out, and measurement is only carried out when the pressure is correct again.

⚠ Caution
If no changeover unit is available for purging, i.e. when operating with only one carrier gas cylinder. The measuring unit must be switched off before changing the cylinder.
The measuring element must be flushed for at least 15 minutes after cylinder replacement. If an alarm message is issued after recommissioning, a service call by RMG is required.

⚠ Caution

If the carrier gas pressure falls below 3 bars, it must be taken into consideration that air may have penetrated into the measuring unit. In this case the measuring unit must be switched off before changing the cylinder.

The measuring element must be flushed for at least 15 minutes after cylinder replacement. If an alarm message is issued after recommissioning, a service call by RMG is required.

Cylinder replacement should take place on notification of an empty cylinder from the contact manometer.

⚠ Caution

The instructions on the cylinder frame must be observed for cylinder replacement.

Air must be prevented from entering the system during cylinder replacement!

Switchover unit for uninterrupted operation

The switchover unit guarantees uninterrupted carrier gas supply when two filled carrier gas cylinders are connected. A cylinder is selected for extraction during operation. Once this cylinder undercuts the minimum cylinder pressure (switchover pressure) setting, the unit automatically switches to the other (still full) cylinder so that the empty cylinder can be replaced. The selector switch located in the middle determines the cylinder from which gas is extracted (if neither of the two cylinders is below the minimum pressure setting).

See also **Figure 27: Gas supply unit**

Cylinder replacement

Carry out the following steps in the specified sequence in order to replace a gas cylinder. The same procedure must also be used for commissioning in order to connect and flush two cylinders in succession. These instructions describe the procedure for the exchange of the left cylinder identified with the letter A. To exchange the right cylinder B, replace A with B in the description.

1. Set the selector switch to cylinder B (arrow points to cylinder B) to replace cylinder A!
2. Close the cylinder valve of A and extraction valve 2A.

3. Open vent valve 1A and close it again after pressure equalization.

⚠ Caution
ATTENTION: (Carrier) gas emerges at the cylinder pressure!

4. Remove the empty cylinder A and connect the full replacement cylinder A.
5. Open vent valve 1A and then open the cylinder valve from A and then close it again.
6. Close 1A again after pressure equalization.

51

⚠ Caution
ATTENTION: (Carrier) gas emerges at the cylinder pressure!

7. Carry out steps (5.) and (6.) two additional times in order to flush the air out of the high-pressure area.
8. Open cylinder valve A and then extraction valve 2A.

At the time of commissioning or if both cylinders must be replaced, carry out steps (1.) to (9.) for cylinder A and for cylinder B in succession. If the line between the switchover unit and valve 2A or valve 2B has not been vented (e.g. with a cylinder replacement during normal operation), the procedure is now finished. Otherwise (e.g. during commissioning), the following steps must be carried out afterwards in order to flush the air out of the entire system.

9. While the carrier gas inlet valve is closed, unscrew the screwed connection at the carrier gas inlet of the RGC 7 until the carrier gas can escape unimpeded. In the process, do not completely unscrew the cap nut.
10. At the secondary pressure regulator of the switchover unit, adjust the extraction pressure as close to 4.5 bar as possible
11. Allow the carrier gas to flow out under extraction pressure for about 2 minutes.
12. Switch the selector switch to the opposite position (cylinder) and allow the carrier gas to flow out for an additional 2 minutes in order to ensure that the air is flushed out of both sides of the switchover unit.
13. Re-tighten the screw connection on the carrier gas inlet of the RGC.
14. Check all lines to ensure that there are no leaks.
15. Use the selector switch to select the cylinder that should be used for extraction during operation.

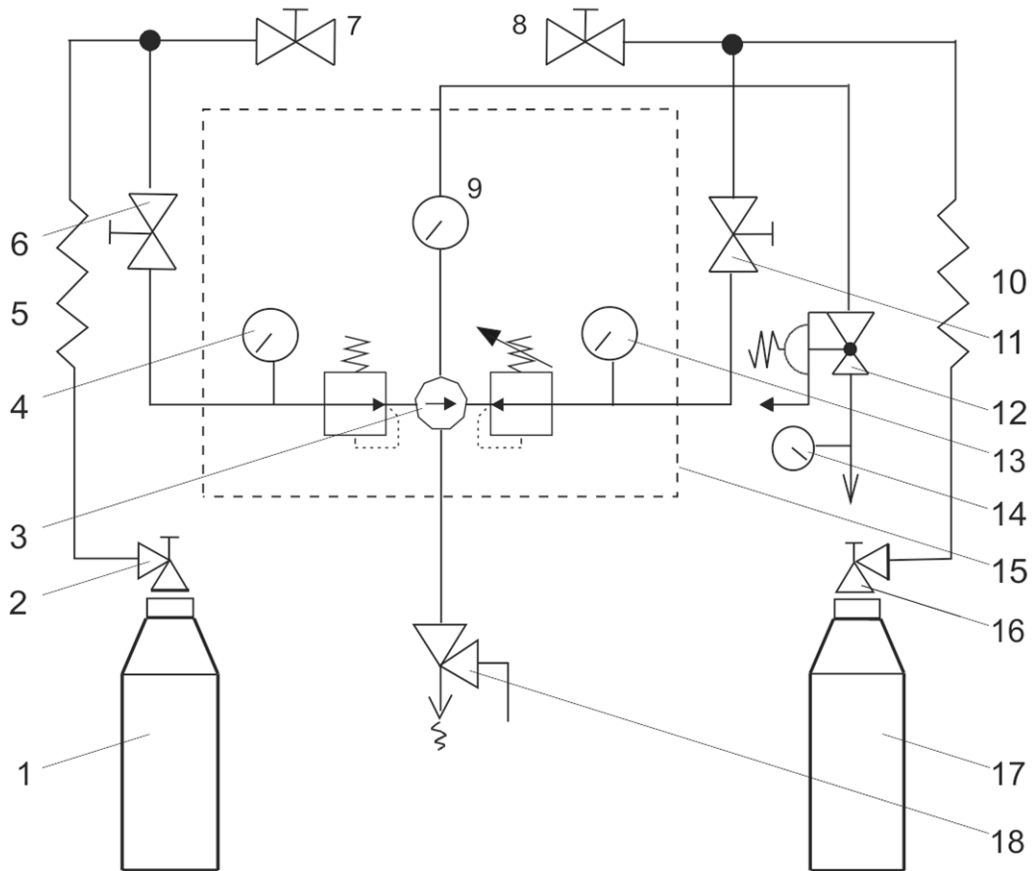

- | | | | |
|---|--|----|--|
| 1 | Carrier gas bottle A
filled with helium max. 200 bar | 10 | High-pressure spiral |
| 2 | Cylinder valve A | 11 | Venting valve 2B |
| 3 | Selector switch | 12 | Pressure regulator |
| 4 | Contact manometer | 13 | Secondary pressure regulator |
| 5 | High-pressure spiral | 14 | Output carrier gas with 4,5 bar |
| 6 | Extraction valve 2A | 15 | Automatic switch block, switch
pressure: 7- 10 bar |
| 7 | Venting valve 1A | 16 | Cylinder valve B |
| 8 | Venting valve 1B | 17 | Carrier gas bottle B
filled with helium max. 200 bar |
| 9 | Output manometer | 18 | SBV opening pressure 13 bar |

Figure 18: Automatic switchover unit type USE-3A block circuit diagram

4.6.4 Replacing the carrier gas filter

⚠ Caution
The molecular sieve column (column module 4) is very sensitive to moisture.

53

Therefore, an additional filter is installed at the carrier gas inlet for all measuring elements with oxygen / hydrogen measurement (*Figure 4: Gas chromatograph RGC 7, Pos. 5*). It is a moisture filter that filters water out of the carrier gas. The filter can be obtained from RMG as spare part; the type designation is:

Gas Clean Moisture Filter

Note
A color indicator shows whether the filter must be replaced. Fields with corresponding colors for ORIGINAL and SATURATED are printed on the filter cap. The filter must be changed when the display field begins to change color. If the indicator completely changes color to SATURATED, damage to the measuring element is possible. The service department must be contacted in this case.

⚠ Caution
We urgently recommend contacting RMG customer service to replace the filter on the RGC 7 to minimize the risk of damage to the measuring element.

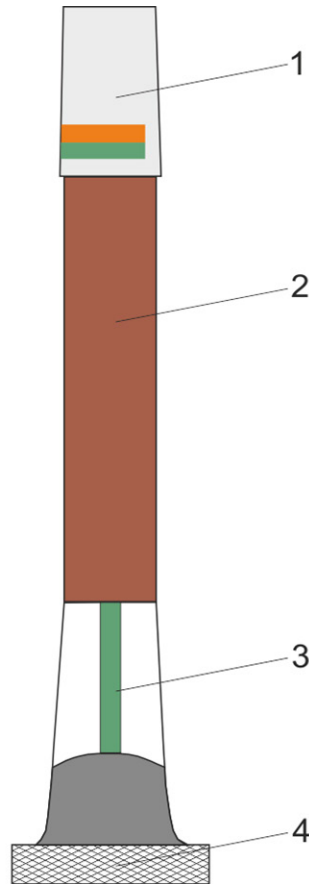

- 1 Filter cap with color codes
- 2 Filter granulate
- 3 Color indicator for moisture
- 4 Knurled fitting

Figure 19: Carrier gas filter

Filter replacement must take place as follows:

Instructions for replacement/disposal

1. Decommission the device as specified in section 6.5 and switch off the measuring element. Observe a possible PGC timeout on the downstream / corrector.
2. An additional shut-off valve behind the filter is used to flush the filter after replacement. Close this valve before changing the filter. Vent the carrier gas line by opening the compression fitting at the valve inlet.
3. Loosen the knurled screw connection and unscrew the filter. Since residual pressure may still be present in the filter, hold the filter firmly with your other hand.

4. Replace O-ring seals on the filter base according to the manual accompanying the filter.
5. Slide the knurled screw connection over the new filter.
6. Remove the metal plug on the new filter.
7. Insert a new filter until it is seated in its guide.
8. Re-tighten the knurled screw connection.
9. Unscrew the clamping ring screw connection on the outlet of the filter base to install the filter by jetting.
10. Start the supply of carrier gas Carrier gas then streams under high pressure at the loosened screw connection.
11. Flush the filter(s) for at least 20 minutes in this manner.
12. Close the screw connection again under flow.
13. The screw connection and area of the knurled screw connection must be checked for leaks with a tracing device.
14. Wait at least 15 minutes until the measuring element has been flushed.

⚠ Caution

An inadequate flushing time can result in irreparable damage to the measuring element!

15. Re-commission the device as specified in 6.5.
16. Enter filter replacement in the maintenance log.

Note

The saturated filter is special waste and must be disposed of according to statutory specifications.

Appendix 3: Pre-filter flushing unit describes how simple replacement with reduced maintenance times can be realized with 2 filter units.

4.6.5 Additional protection from moisture of RGC 704

To protect the RGC 704 from moisture, the housing is purged with argon. For this purpose, the outflow line of the argon carrier gas is led directly into the housing. In addition, a dry agent cartridge is placed in the housing to absorb ambient moisture. See figure 8: Design of the analysis unit gas distribution, Pos. 5.

5 Measuring element operating modes

56

The measuring element operating modes can be adjusted in the "Details" screen of the analytical computer under RGC 7-C mode/operating mode (refer to the manual for RGC7-manual_en).

5.1 Automatic analysis mode / autorun

Automatic analysis mode ("autorun") is the normal operating mode of the measuring element. A cyclical sampling and analysis of the measuring gas are carried out. This process is only interrupted by the automatic recalibration ("Details" screen under calibration parameters).

5.2 Stop mode

This mode is activated in order to switch off the analysis mode. After the current analysis is finished, the continuous operation is interrupted.

5.3 Normal calibration

A switchover to the calibration gas inlet and implementation of a calibration cycle according to the defined data ("Details" screen under calibration parameters) are carried out. After the calibration is finished, the valves are switched back to the measuring gas inlet and a continuous analysis of the measuring gas is conducted. The timing of the next automatic recalibration is not changed.

5.4 Reference gas analysis

The reference gas inlet (for test gas) is switched on and a continuous analysis is conducted. However, the maximum number of analyses that can be carried out are specified in "Detail--> 01 operating mode Refgas--> Number of runs (max 500). Then an automatic switch to "Autorun" occurs.

After re-calibration, the external calibration gas is analyzed via the reference gas inlet. This is a normal analysis and the correction factors from the last automatic or manual calibration remain unchanged.

5.5 Basic calibration

57

A calibration cycle is triggered and the determined factors are stored in the computer as response factors of the basic calibration together with the retention times. A basic calibration must not be performed during normal analysis operation. This function is located under the calibration lock.

After the calibration cycle, the system switches to "Autorun".

Retention times and response factors (RT, RF) are also determined during normal calibration.

The difference is that in the basic calibration, the times and factors found are additionally stored as retention times at zero (RTZ) and response factors at zero (RFZ). The monitoring of the drift of these values is reset and with each normal calibration only RT and RF are determined and compared with RTZ and RFZ. Exceeding the limit values (according to the approval) leads to an alarm.

Appendix 1: Technical data

58

Voltage supply:	20 V DC - 28 V DC
Power consumption:	Measuring element: max. 75 W
Housing heating	50 W
Typical:	150 W
Start-up current:	10 A in the first 3 minutes
in normal operation	approx. 1.5 A
Air humidity:	5% - 95% relative humidity
Condensation not permitted.	
Safety classification:	 II 2G Ex db eb IIB+ H2 T4 Gb

Note

The room temperature at the installation site must be between -20 °C and 55 °C. The temperature limits specified in the calibration gas certificate apply to the calibration gas cylinder and the calibration gas supply lines.

Dimensions:	see <i>Figure 4: Gas chromatograph RGC 7</i>
Weight:	60 kg

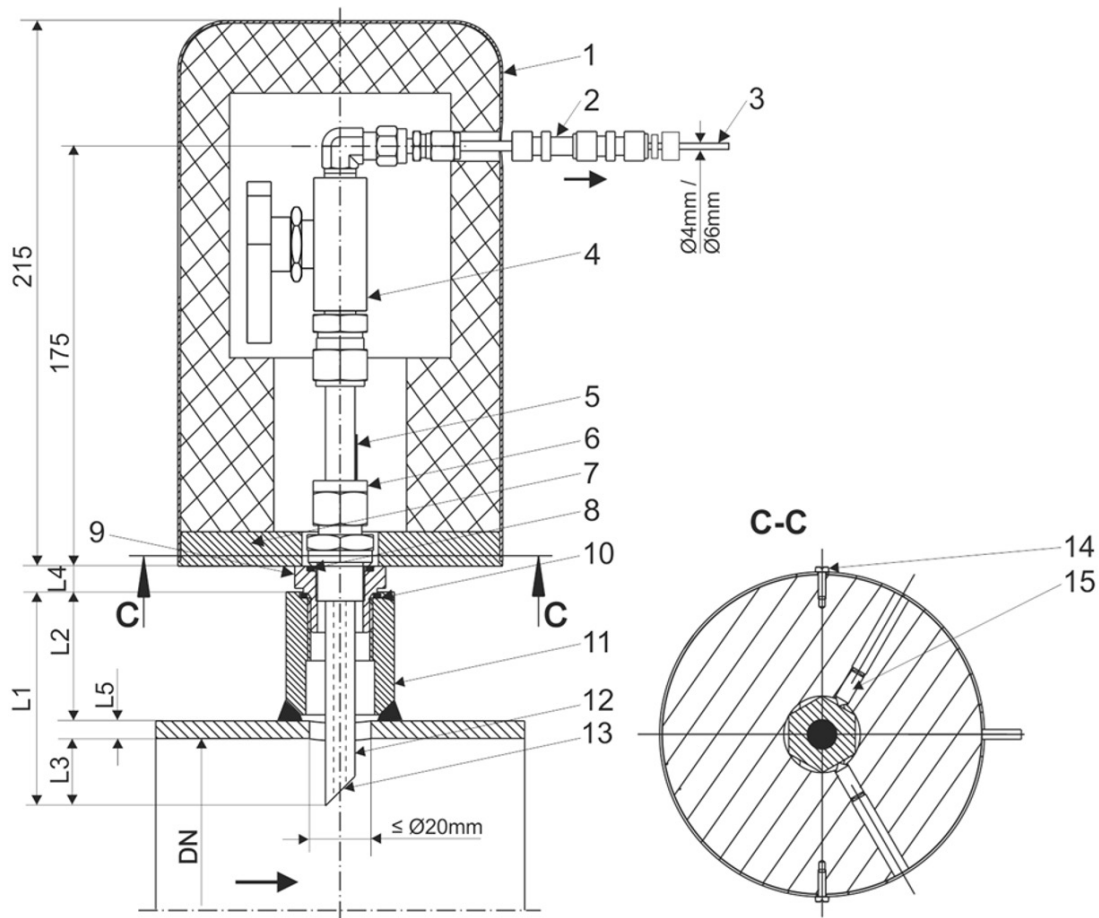

- | | |
|---|--|
| <ul style="list-style-type: none"> 1 Aluminum insulated protective hood with bottom disk (option) 2 Insulating gland for electrical isolation (option) 3 Connection tube 4 Ball valve 5 Red mark 6 Threaded fitting G1/2" 7 Bottom plate 8 Sealing ring according to DIN7603 made of aluminum for screw-in fitting G1/2". 9 Adapter for G3/4" and G1" sleeve 10 Sealing ring according to DIN7603 made of aluminum for adapter G3/4" and G1". | <ul style="list-style-type: none"> 11 Sleeve G1/2", G3/4" or G1" with screw-in hole according to DIN 3852-2 form X or Y. Available on site. 12 Probe tube (tube Ø12 x 4) 13 The slope of the probe must be against the direction of flow. Alignment by red color marking on the probe. 14 Cross-hole screw with sealing option (option with protective hood) 15 Threaded pin with tip for fastening the bottom washer to the 6-sided screw fitting (option for protective hood) |
|---|--|

- | | | |
|--------------------------|-------------------------|------------------------------|
| L1 Probe tube length | L2 Height of the sleeve | L3 Insertion depth (Pos. 12) |
| L4 Height of the adapter | L5 Pipe wall thickness | |

Figure 20: Sampling probe PES 50S

Technical description

Operating pressure max.150 bar at
Operating temperature: -40°C to +93°C. Other temperature ranges upon request.

60

All probe components are made of stainless steel. Fittings / stopcocks from Swagelok.

Preferably use sleeve with G1/2" thread. The adapter (Pos. 9) is not necessary.

Recommended sleeve height L2=50mm

L4 for a 1/2" sleeve = 0mm

L4 for a 3/4" sleeve = 25mm

L4 for a 2" sleeve = 11mm

Recommended insertion depth L3 at:

(DN50-DN100) L3=1/3DN

(DN150-DN600) L3=1/3DN, (min.50mm)

It should be noted that the hole in the pipeline must be centric to the socket and have a diameter of min. 20mm.

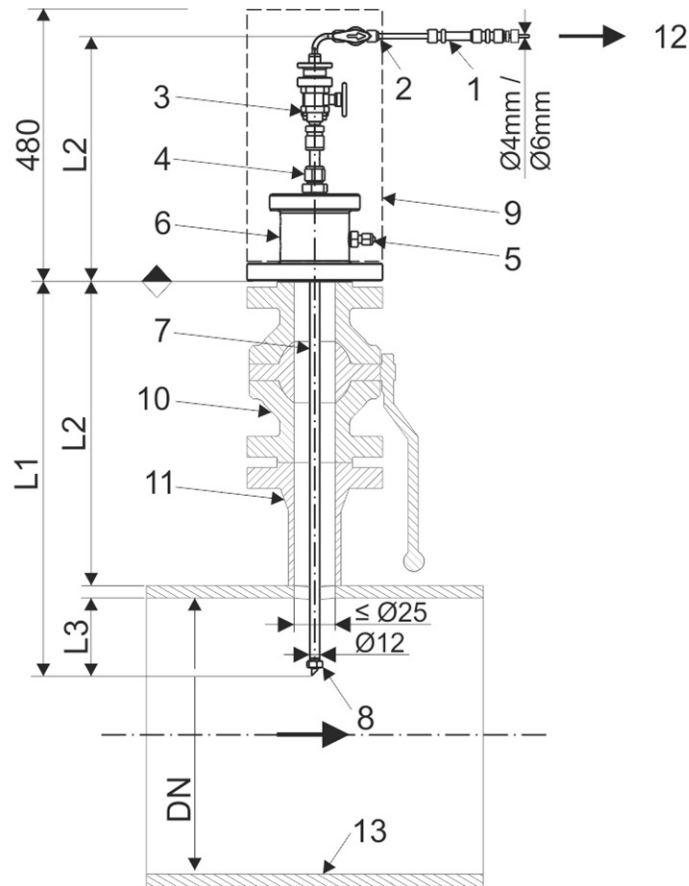

- | | |
|--|--|
| 1 Insulating gland for electrical isolation (option) | 8 Ball valve (provided by customer) |
| 2 Stopcock | 9 Weld-on socket (provided by customer) |
| 3 Stopcock with support ring for retraction tool | 10 Extension stop (nut M10) |
| 4 Straight-through fitting | 11 Gas line |
| 5 Venting valve | 12 Sample output |
| 6 Connection head with flange connection | 13 Stainless steel insulation cover (optional) |
| 7 Probe tube Ø12 mm | |

Figure 21: Sampling probe Type PPS 02-R

Technical description

Operating pressure (PN) max. 100 bar

Operating temperature: -28°/+65°C

62

All probe components are made of stainless steel

O-rings made of 72 NBR 872

Fittings / stopcocks from Swagelok.

Connection head with flange connection according to ASME B16.5:

Flange ANSI 2":

ANSI 150 RF, ANSI 150 RTJ, ANSI 300 RF, ANSI 300 RTJ

ANSI 600 RF and ANSI 600 RTJ.

The immersion depth L1 can be adjusted between 430-530mm during initial assembly. The probe height L2 is between 300-400mm depending on the set immersion depth L1. The immersion depth L3= 1/3DN, (min. 50mm)

The pipe section to be welded on, the ball valve, the seals, screw bolts and nut between the probe and the ball valve are not included in the scope of delivery.

It should be noted that the hole in the pipeline must be centric to the socket and have a diameter of min. 25mm.

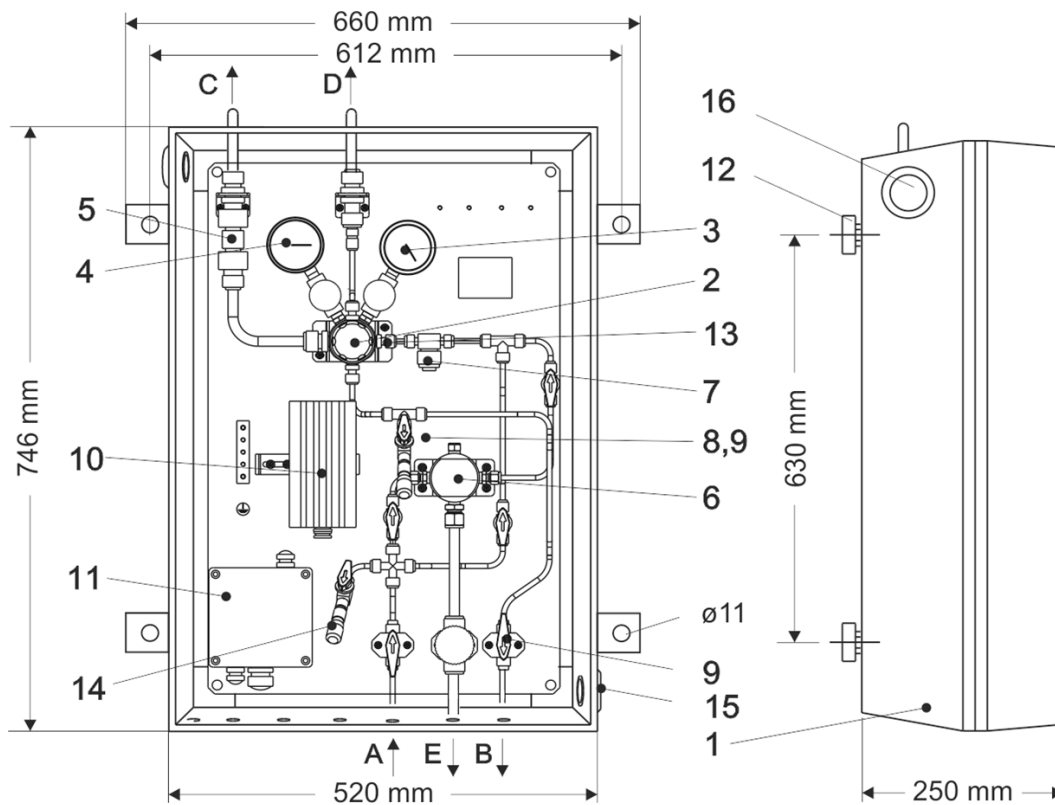

- | | |
|---|--|
| <ul style="list-style-type: none"> 1 Insulating protection box with window 2 Pressure reducer
Input pressure max. 100 bar
Output pressure 0,14-7 bar 3 Pre-pressure manometer,
selectable 0-160, 0-100, 0-40 bar 4 Back pressure manometer,
selectable *0-6, 0-10 bar 5 SBV with 3 bar opening pressure 7 Sintered metal filter 8 Test port inlet pressure range with shut-off
valve
(mini measuring coupling series 1215) 9 Stopcock 10 Ex-heater 100W with 30°C fixed thermo-
stat in connection cable-frost-free down to
-25°C 11 Ex(e)(i) terminal box for item no. 10 and
heating analysis line 12 Wall mounting bracket 13 Limiting aperture \varnothing 0,4mm | <p>Options:</p> <ul style="list-style-type: none"> 6 Coalescence filter with bypass line 14 Test port inlet pressure range with shut-off
valve
(mini measuring coupling series 1215) 4 *With limit value signal transmitter (adjustable) <p>A. Measurement input
B. Measurement output
C. Blow-off line from SBV (12mm tube)
D. Breathing line from pressure regulator (12mm
tube)
E. Condesate output (12mm tube)</p> <p>Supply line for ports A, B:
Standard – 4 mm tube,
Options - 1/8"-, 6 mm tube.
Customer connections in the
Swagelok system (stainless steel)</p> <p>Total weight approx. 30kg</p> |
|---|--|

Figure 22: DRS 200 pressure reducing stage (wall mounting)

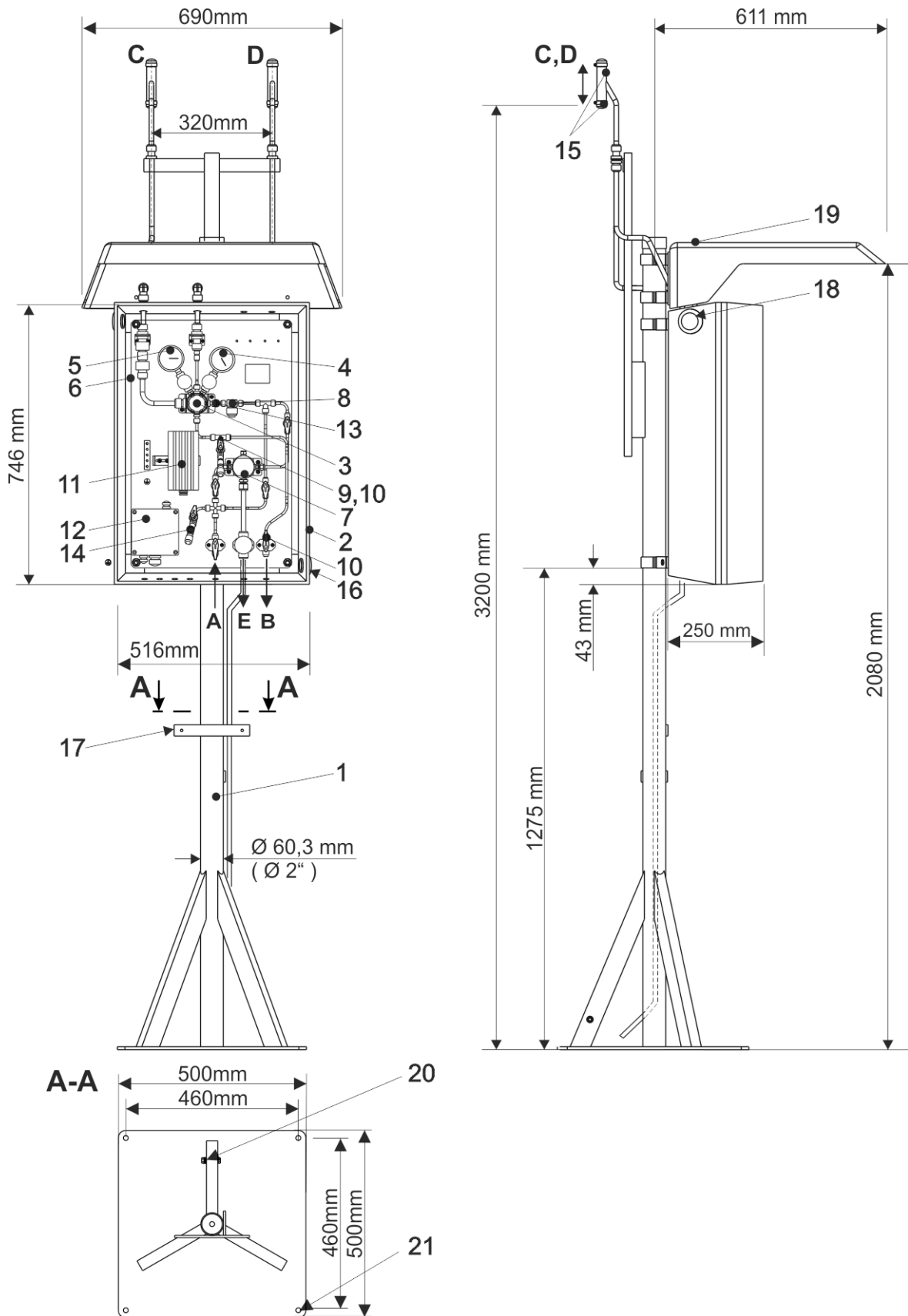

<ul style="list-style-type: none"> 1 Support (stainless steel) 2 Insulating protection box with window 3 Pressure reducer Input pressure max. 100 bar Output pressure 0,14-7 bar 4 Pre-pressure manometer, selectable 0-160, 0-100, 0-40 bar 5 Back pressure manometer, selectable *0-6, 0-10 bar 6 SBV with 3 bar opening pressure 8 Sintered metal filter 9 Test connection -low pressure range with shut-off valve (Miniature coupling series 1215) 10 Stopcock 11 Ex-heater 100W with 30°C Fixed value thermostat in the connection cable - Frost-free up to -25°C 12 Ex(e)(i) terminal box für Pos. no.11 and Heater analysis line 13 Limiting aperture $\varnothing 0,4$ mm 15 Insect protection mesh 16 Ventilation 17 Cable support rail 18 Ventilation 19 Protective canopy 20 PE-screw 21 Bore $\varnothing 11$mm 	<p>Options:</p> <ul style="list-style-type: none"> 7 Coalescence filter with bypass line 14 Test port pre-pressure range with Shut-off valve (Miniature coupling series 1215) 5 With limit value signal transmitter (adjustable) A Measurement input B Measurement output C Blow-off line from SBC (12mm tube) D Breathing line from pressure regulator (12 mm tube) E Condensate output (12 mm tube) Supply line for ports A, B: Standard - 4mm tube, Options - 1/8"-, 6 mm tube. Customer connections in the Swagelok system (stainless steel). Total weight approx. 70 kg 	<hr style="width: 100%;"/> <div style="border: 1px solid black; width: 30px; margin: 0 auto; text-align: center;">65</div> <hr style="width: 100%;"/>
--	--	---

Figure 23: DRS 200 pressure reducing stage (stand version)

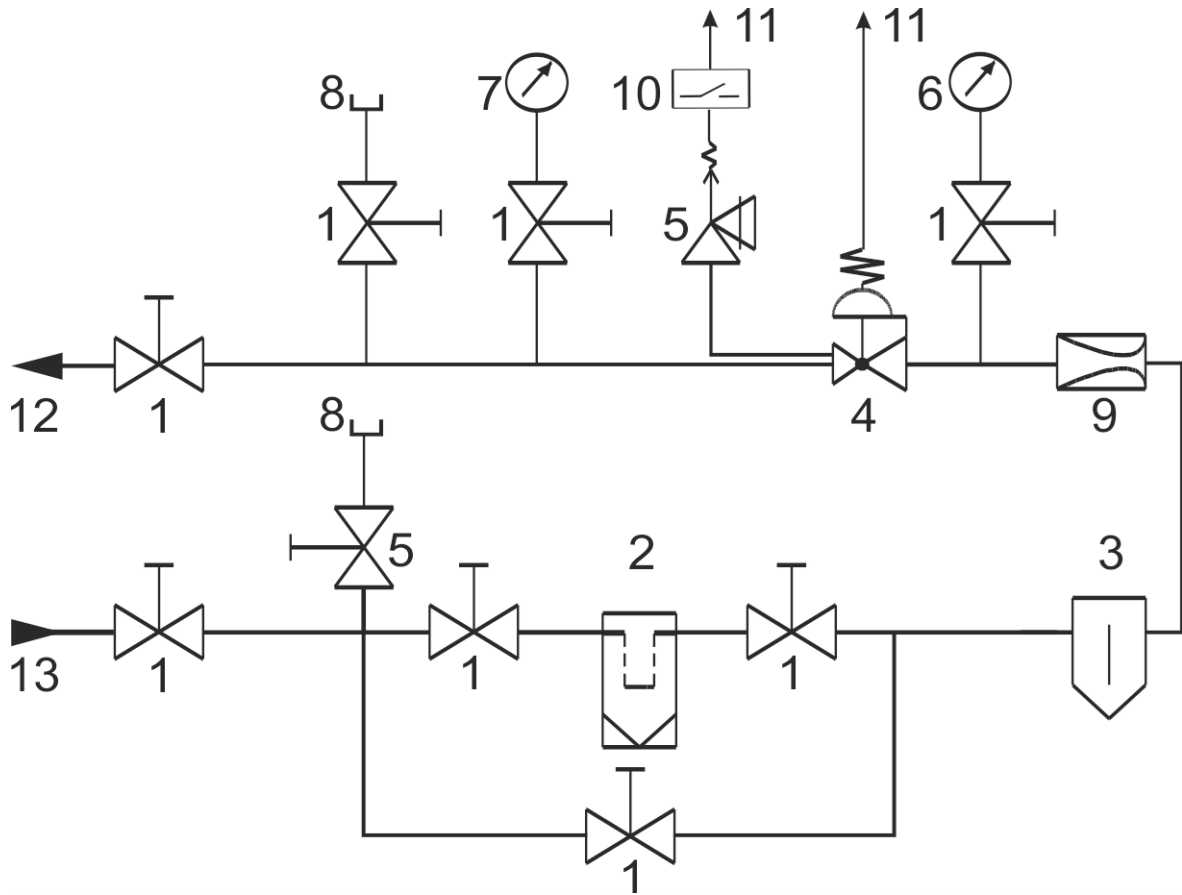

- | | |
|----------------------------|-----------------------------------|
| 1 Shut-off valve | 8 Mini measuring coupling |
| 2 Coalescence filter | 9 Limiting blind |
| 3 Filter | 10 Flow monitor SBV (option) |
| 4 HD-Pressure reducer | 11 To the open air |
| 5 SBV | 12 Output pressure = 0,14-7 bar |
| 6 Pre-pressure manometer, | 13 Input pressure = 100 bar (max) |
| 7 Back pressure manometer, | |

Figure 24: DRS 200 pressure reducing stage (Functional diagram)

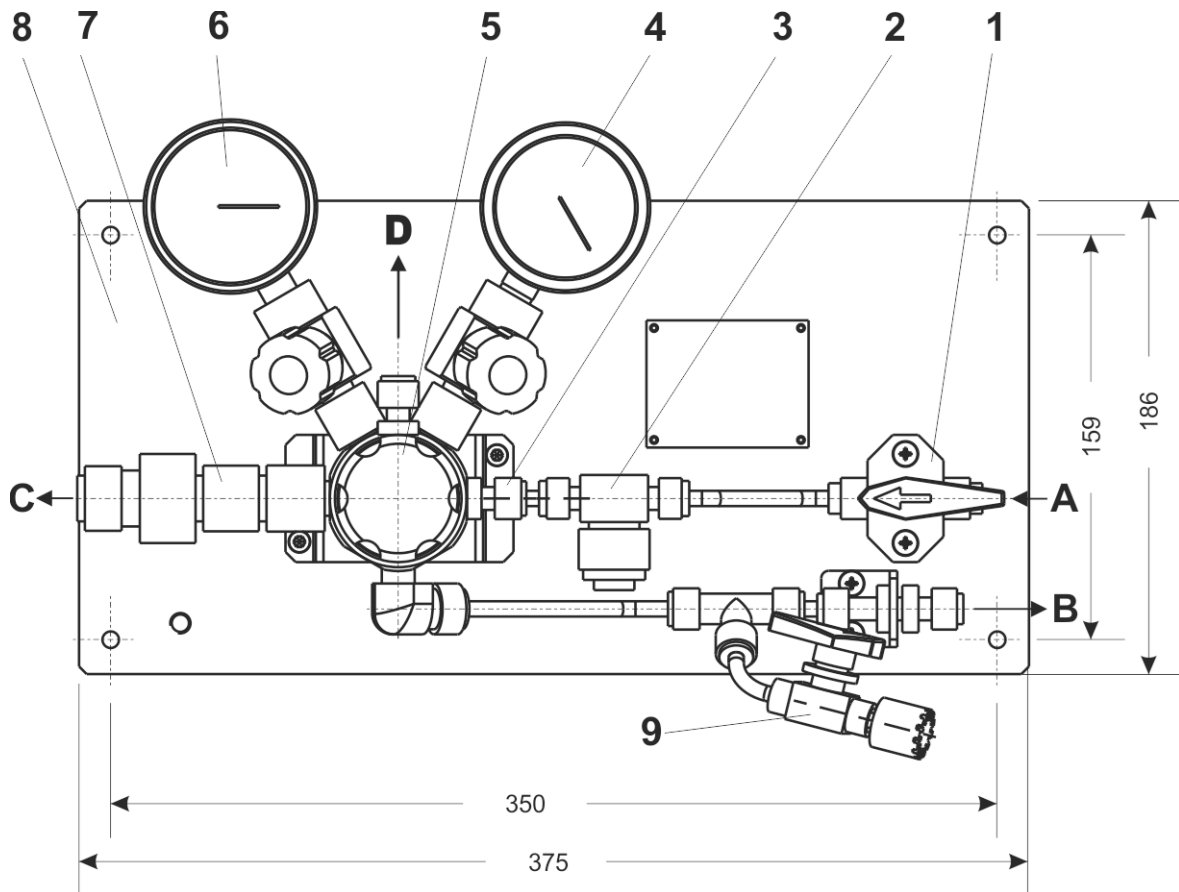

- 1 Shut-off valve
- 2 Filter
- 3 Limiting blind
- 4 Input manometer 0-160 bar
optionally 0-100 bar, 0-40 bar
- 5 High-pressure reducer
Input: max. 100 bar
Output: 0.14- 7 bar
- 6 Output manometer 0-6 bar
optionally with reed contact sensor
optionally 0-10 bar
- 7 Safety shut-off valve (SBV)
with 3 bar opening pressure
- 8 Assembly plate (Al)
- 9 Test connection
(Miniature coupling series 1215)

Connections:

- A Measurement input
6 mm tube on Swagelok
Fittings
(Option 1/8", 3 mm, 4 mm)
- B Measurement output
6mm tube on Swagelok.
Fittings
(Option 1/8", 3mm, 4mm)
- C Blow-off line SBV
12mm tube on Swagelok
Fittings
- D Breathing line regulator
12mm tube on Swagelok.
Fittings

Option:

Wall mounting

Figure 25: DRS 100 pressure reducing stage

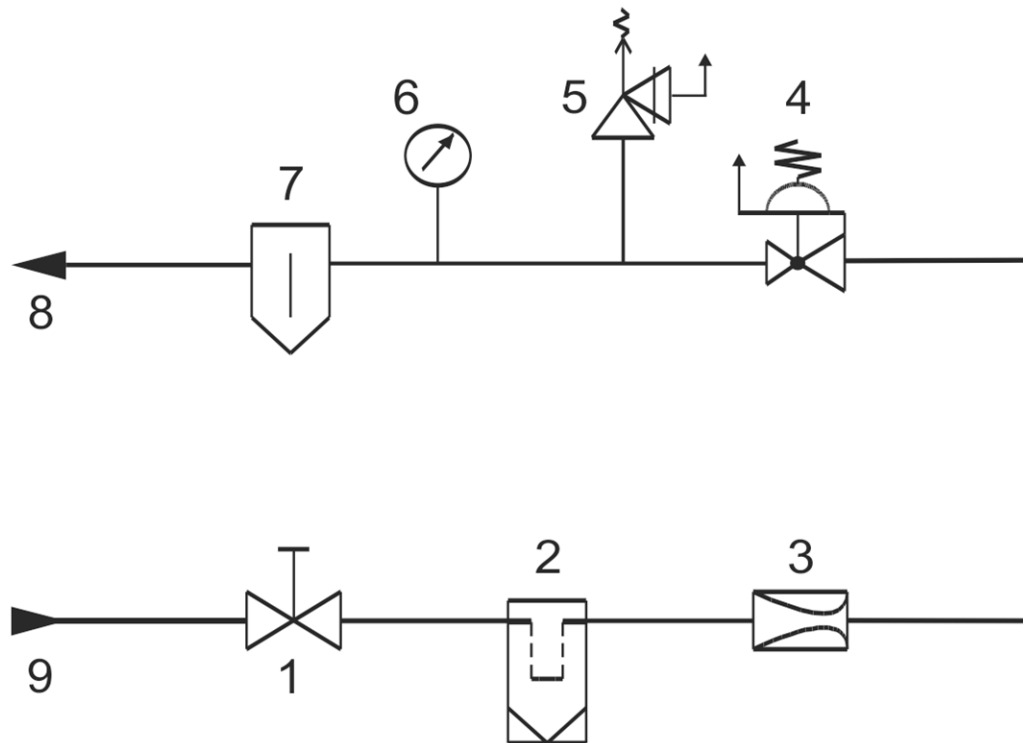

- | | |
|-----------------------------------|-------------------------------------|
| 1 Shut-off valve | 6 Back pressure manometer, 0-16 bar |
| 2 Filter | 7 Dryer |
| 3 Choke | 8 Output pressure = 0-8 bar |
| 4 Pressure reducer 100/ 8 bar | 9 Input pressure = 100 bar |
| 5 SBV with 8 bar opening pressure | |

Figure 26: DRS 100 pressure reducing stage (Functional diagram)

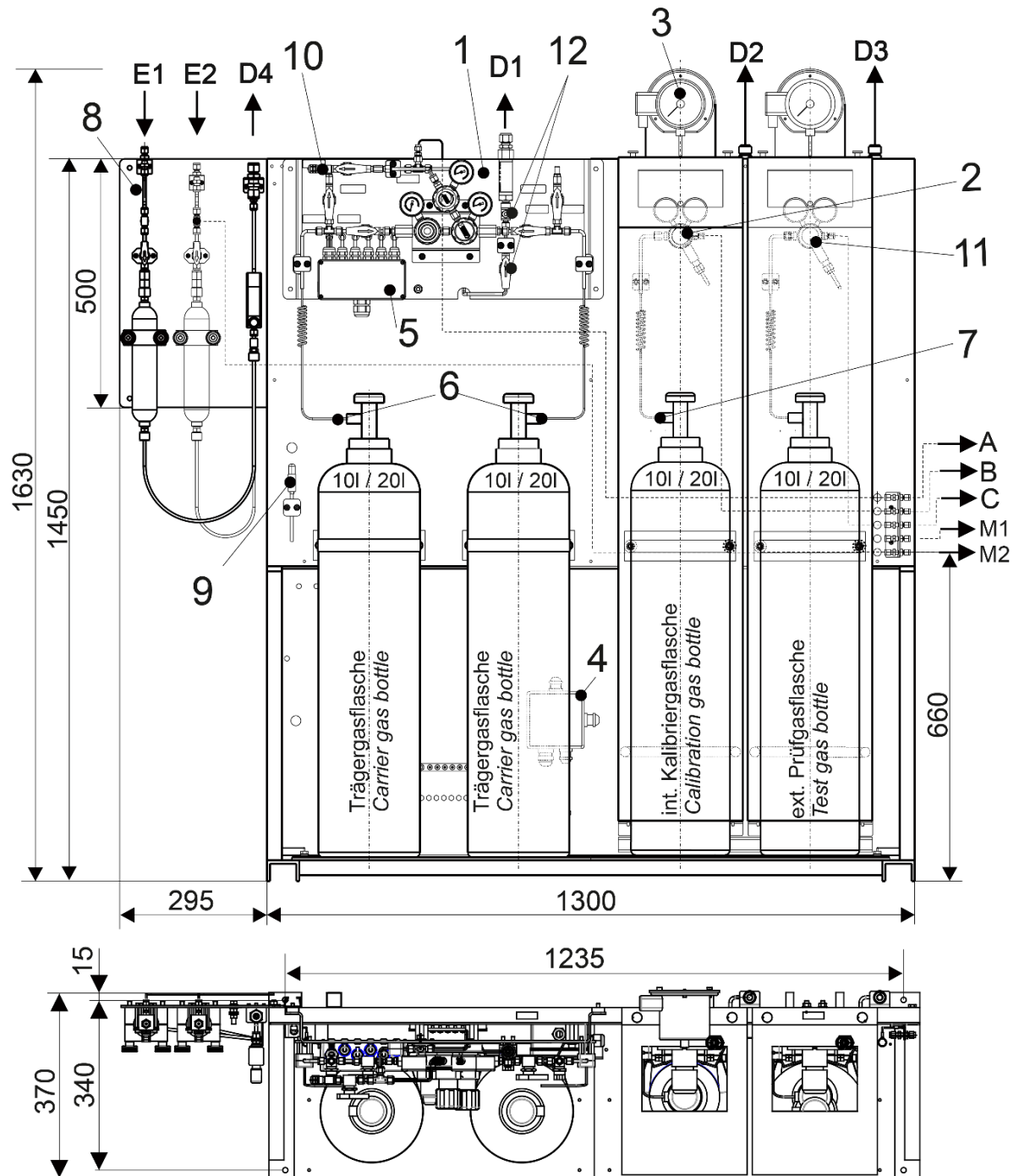

- | | |
|---|---|
| <p>1 Switching unit automatic HP255 for two carrier gas bottles 10l / 20l</p> <p>2 int. calibration gas bottle 10l / 20l (heated) with high pressure reducer and relief valve</p> <p>3 Thermometer for bottle temperature</p> <p>4 Ex(e) connection box for ex-bottle-heating</p> <p>5 Ex(i) connection box for contact gauge (carrier gas bottles) and bottle and ambient thermometer</p> <p>6 High pressure spiral (stainless steel) with Bottle connection acc. to DIN 477 No. 6 or acc. to BS 341, no. 3</p> <p>7 High pressure spiral hose (stainless steel) with bottle connection acc. to DIN 477, No. 14 or BS 341, no. 4</p> <p>8</p> <p>9</p> | <p>Option:</p> <p>8 Manual sample taking (inlet pressure max. 3 bar) 300 ml Testing cylinder Ø 50 mm (by customer)</p> <p>9 Ambient thermometer</p> <p>10 Test connection with coupling</p> <p>11 Test gas bottle 10l / 20l (heated) with high pressure reducer and relief valve</p> <p>12 Functional test relief valve</p> <p>Connections:</p> <p>A Carrier gas outlet</p> <p>B Calibration gas outlet</p> <p>C Test gas outlet</p> <p>M1/2 Sample gas outlet</p> <p>D1 Vent line (carrier gas)</p> <p>D2 Vent line of relief (test gas)</p> <p>D3 Vent line of relief (test gas)</p> <p>D4 Vent line sample gas flowmeter</p> <p>E1 Sample gas inlet 1</p> <p>E2 Sample gas inlet 2, option</p> <p>1/8" tube for connections A, B, C, M
 Ø 4 mm tube for connections E1, E2
 Ø 12 mm tube for connections D1-D4</p> <p>Weight without bottles approx. 94 kg</p> |
|---|---|

All tube fittings and connections with clamping-system made of stainless steel

Figure 27: Gas supply unit
 With switching unit for two carrier gas cylinders 10/20l

Appendix 2: Error messages

Errors are output by the analytical computer as a text message with a specific number. The error numbers are output in the print logs.

A complete list is provided in chapter 5.7 of the RGC 7-C manual.

Only the error messages directly related to the analysis should be addressed here.

Appendix 2 A: Error in continuous analysis mode

Number	Text	Description	Cause
14 - 17	Current output - # alarm limits	Current < 0/2 mA and/or > 21mA	- Check of limit values in the "Detail" screen under "inputs and outputs"
50	Measuring element timeout	The measuring element no longer provides valid data.	- Communication error - Error in the measuring element
		<u>Communication error</u> The measuring element works correctly, but there are no measurements received by the analytical computer.	- Wire break - Incorrectly specified TCP/IP address in the analytical computer
120	Ana: Retention time	The retention time of one or multiple gas components deviates impermissibly from the base values. (Retention times in the "Detail" screen for the individual components, permissible deviation under "Computing parameters / limit values ana.,cal.")	- Faulty pressure/temperature values (with error 50) - Impermissible gas composition (with error 121, 122) - defective column module
121	Ana: abnormal sum.	With standardization to 100%, the limit value is exceeded ("Calibration results/surface totals" and "Calibration parameters/limit values cal.").	- impermissible gas composition - Pressure/temperature error (50) - defective column module
122	Ana: Concentration	Working range of the modules exceeded and/or undercut	- impermissible gas composition
123, 82, 124, 127	Ana: Ho min/max CO ₂ min/max Ana: Wo min/max Ana: Rho,n min/max	Measuring range exceeded and/or undercut	- Check of limit values in the "Detail" screen under "Components and parameters"
130	Sample gas pressure for Injection	Depending on the inlet that is switched on, the inlet pressure of the measuring/calibrating or reference gas is outside of the tolerance.	- Incorrect setting - Cylinder pressure - Check "Status" screen
131	Carrier gas pressure -I	The carrier gas inlet pressure is outside of the tolerance.	- Incorrect setting - Cylinder pressure - Check "Status" screen

Appendix 2 B: Errors during recalibration

The following errors are only issued during the recalibration and/or basic calibration. If one of these errors occurs, the calibration is invalid. The previous response factors are retained. All of the subsequent measurements are marked as faulty.

These errors cannot be acknowledged and are not reset until a valid recalibration takes place.

Number	Text	Description	Cause
100	Cal: Retention time	The newly determined retention times (current and/or stream values under "Times") deviate impermissibly from the specified values ("Computing parameters / Ana., Cal. limit values")	<ul style="list-style-type: none"> - Pressure / temperature error during recalibration. - Calibrating gas supply - Incorrect specification of the calibration gas concentration (Screen "Detail" under "Calibration Parameters") - defective column module
101	Cal: Response factor	The newly calculated response factors show an impermissible deviation ("Detail" screen under "Calibration results" and "Calibration parameters / Cal. limit values")	- see 100
103	Cal: Total surface	The total surface determined in the calibration deviates by more than 30% from the value of the basic calibration.	- see 100

Appendix 2 C: Mains failure of the RGC 7-C

After a mains failure of the analytical computer (Error 02 - Mains failure), a self-test is carried out by the device after a restart. When this process is completed and the measuring element is ready, a calibration is initiated automatically (after a specified wait time). The analysis operation resumes after the calibration.

Appendix 3: Pre-filter flushing unit

The optionally available pre-filter flushing unit allows a carrier gas moisture filter to be changed while the downstream RGC 7 is in operation. This significantly reduces interruptions to operating times due to filter replacement work.

To ensure the continuous operation of the RGC 7, two carrier gas humidity filters with associated inlet, outlet and vent valves are arranged redundantly in the pre-filter purge unit. The carrier gas flow can always be fed to the RGC 7 via one filter with the corresponding valve position, while the second filter is changed and then flushed.

The pre-filter flushing unit must be installed in the carrier gas line upstream of the RGC 7 (see *Figure 28: Installation diagram*).

Simple assembly

In order to enable easy replacement of the original pre-filter unit with the optional pre-filter flushing unit, the components were mounted on a base plate of the same size.

The external dimensions, the hole pattern of the wall mounting and the position of the carrier gas connections are identical to the original version. This means that when the pre-filter unit types are changed, they can be replaced without any problems.

Installation diagram

The following figure shows the functional arrangement of the pre-filter flushing unit in the carrier gas line.

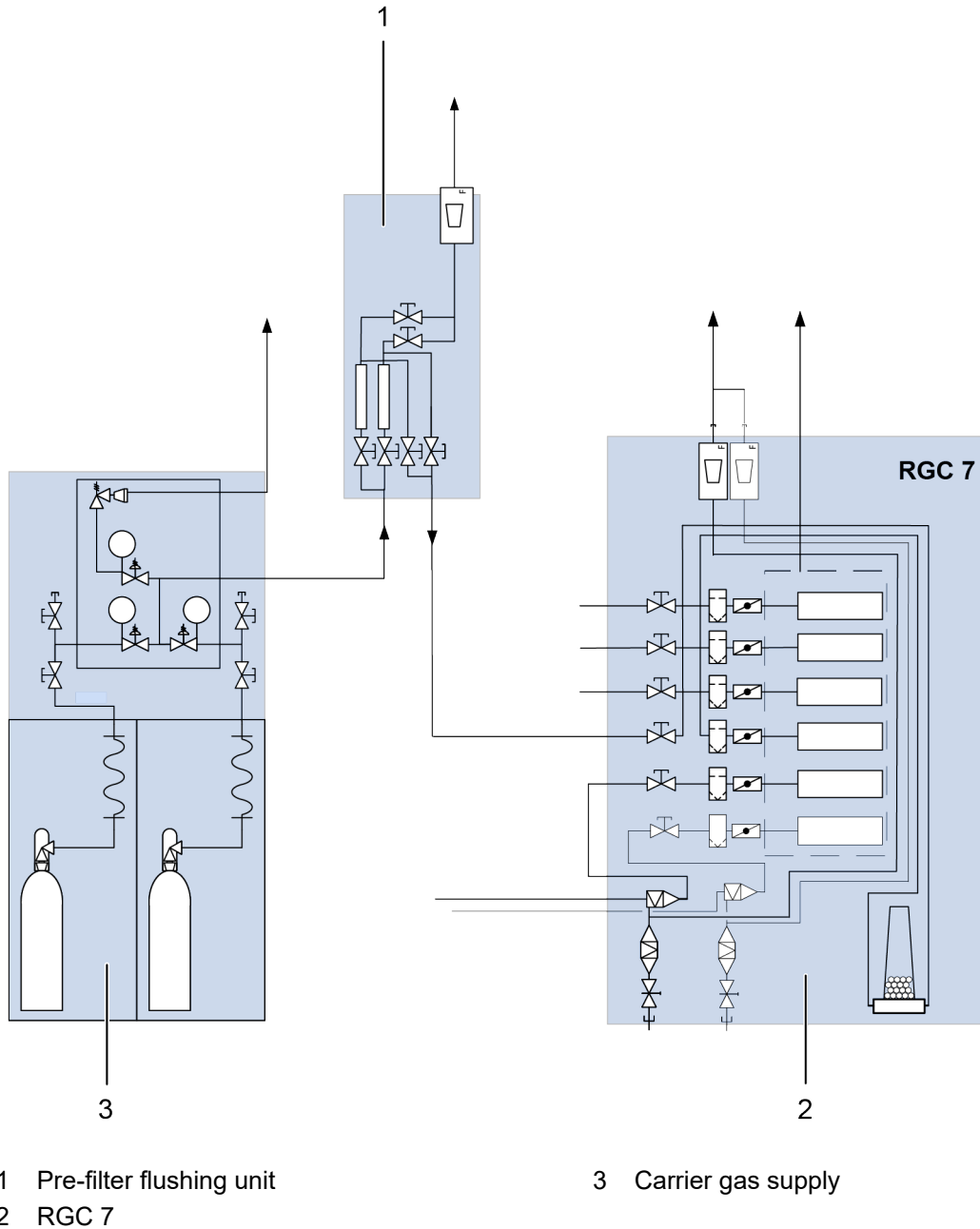
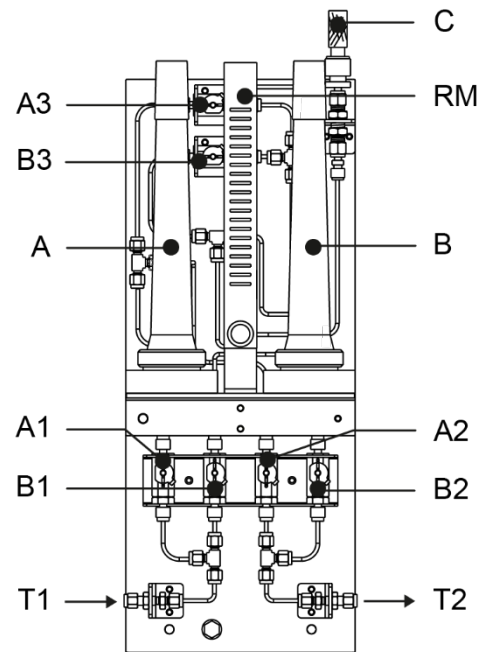
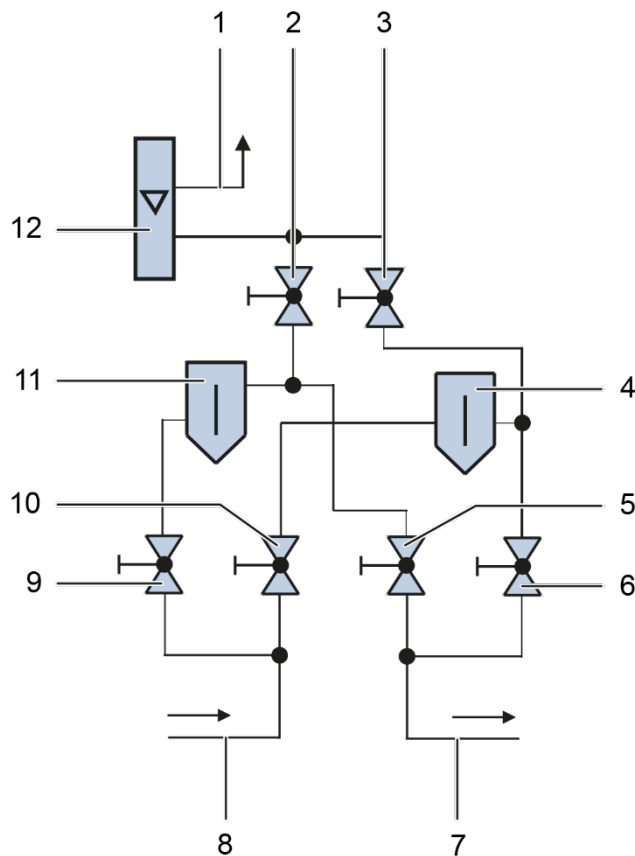

Figure 28: Installation diagram

Functional diagram

The *Figure 29: Functional diagram and technical drawing* shows the components of the pre-filter flushing unit and their functional and actual arrangement. The *Figure 30: Pre-filter flushing unit without filter equipment* shows the photo of a prototype of the unit.



Item P&I	Item Drwg	Description	Item P&I	Item Drwg	Description
1	C	Connection to the blow-out pipe	7	T2	Outlet connection of the carrier gas to the RGC 7
2	A3	Shut-off valve Rinsing outlet filter A	8	T1	Inlet connection of the carrier gas from the gas supply
3	B3	Shut-off valve Rinsing outlet filter B	9	A1	Shut-off valve inlet filter A
4	B	Filter B (right filter)	10	B1	Shut-off valve inlet filter B
5	A2	Shut-off valve outlet filter A	11	A	Filter A (left filter)
6	B2	Shut-off valve outlet filter B	12	RM	Rotameter, adjustable

Figure 29: Functional diagram and technical drawing

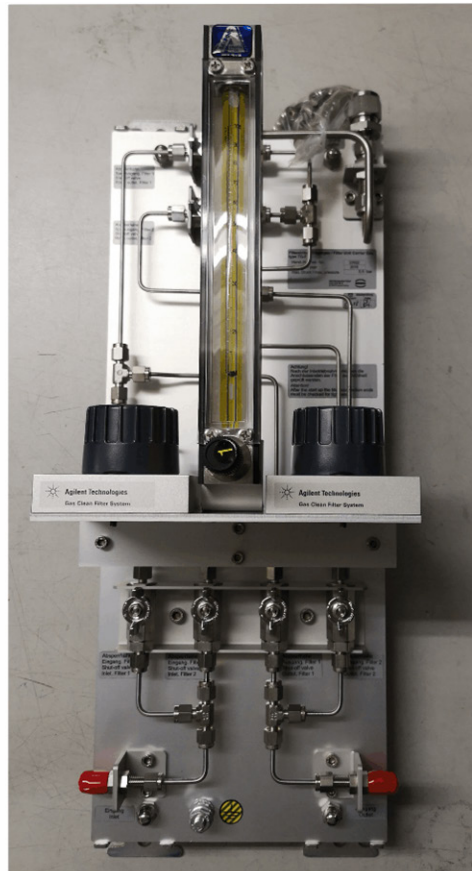

Figure 30: Pre-filter flushing unit without filter equipment

Pre-filter flushing unit brief operating instructions

Initial startup:

1. All valves are closed, no filter is used.
2. Switch HE filter to Pos. A.
3. Open valve A1.
4. Open valve A3.
5. Adjust rotameter RM for flushing operation to 10-15 ml.
Flush 24 h.
6. Close valve A3.
7. Open valve A2 (Filter A in operation).

 77

Use new Filter B, Filter A is in operation:

1. Switch HE filter to Pos. B.
2. Open valve B1.
3. Open valve B3.
4. Adjust rotameter RM for flushing operation to 10-15 ml.
Flush 24 h.
5. Close valve B3.
6. Close valve A2.
7. Open valve B2.
8. Close valve A1.
9. Open valve A3 for ventilation and close again.
10. Filter A can be removed.

Use new Filter A, Filter B is in operation:

1. Switch HE filter to Pos. A.
2. Open valve A1.
3. Open valve A3.
4. Adjust rotameter RM for flushing operation to 10-15 ml.
Flush 24 h.
5. Close valve A3.
6. Close valve B2.
7. Open valve A2.
8. Close valve B1.
9. Open valve B3 for ventilation and shut again.
10. Filter B can be removed.

Appendix 4: Certificates

The RGC 7 is approved for custody transfer measurements. Approvals are available for operation in hazardous environments, which are provided as copies in the appendix.

1. EU Declaration of conformity
2. ATEX-Certificate: EU type examination Certificate
3. IECEx-Certificate: Certificate of conformity
4. MessEV, Annex 4 Modul B: Type examination Certificate

79

Note

EU declaration of conformity

The declaration of conformity presented reflects the situation on the data when the operating manual was issued. The latest version of the EU declaration of conformity is available from our website www.rmg.com.



EU-Declaration of Conformity
EU-Konformitätserklärung



We **RMG Messtechnik GmbH**
Wir Otto – Hahn – Straße 5
35510 Butzbach
Germany

Declare under our sole responsibility that the product is in conformity with the directives. Product is labeled according to the listed directives and standards and in accordance with the Type-Examination.

Erklären in alleiniger Verantwortung, dass das Produkt konform ist mit den Anforderungen der Richtlinien. Das entsprechend gekennzeichnete Produkt ist nach den aufgeführten Richtlinien und Normen hergestellt und stimmt mit dem Baumuster überein.

Product **Process Gas Chromatograph RGC 704**
Produkt **Prozess- Gaschromatograph RGC 704**

Directive <i>Richtlinie</i>	EMV	ATEX
EC- Directives <i>EG-Richtlinie</i>	2014/30/EU	2014/34/EU
Product marking <i>Produktkennzeichnung</i>	0158	II 2G Ex db eb IIB+H ₂ T4 Gb
Standards <i>Normen</i>	EN 61326-1:2013 OIML R 140:2007 IEC 61000-4-2: IEC 61000-4-3: IEC 61000-4-4: IEC 61000-4-5: IEC 61000-4-6: IEC 61000-4-8: 1993 EN 61000-4-11	EN IEC 60079-0:2018 EN 60079-1:2014 EN IEC 60079-7:2015 + A1:2018
EC Type-Examination <i>EG-Baumusterprüfung</i>	Prüfbericht / Test Report: 1-1289/20-01-02 CTC advanced GmbH	BVS 22 ATEX E 045 X
Accredited certification <i>Überwachungsinstanz</i>	--	DEKRA Testing and Certification GmbH (0158) Germany

The RGC 704 also has a type-examination Certificate with the Certificate No.: DE-21-M-PTB-0076
Der RGC 704 verfügt zusätzlich über eine Baumusterprüfbescheinigung mit der Bescheinigungsnummer: DE-21-M-PTB-0076

The object of the declaration described above is in conformity with Directive 2011/65/EU of the European Parliament and of the Council of 8 June 2011 on the restriction of the use of certain hazardous substances in electrical and electronic equipment.

Der oben beschriebene Gegenstand der Erklärung erfüllt die Vorschriften der Richtlinie 2011/65/EU des Europäischen Parlaments und des Rates vom 8. Juni 2011 zur Beschränkung der Verwendung bestimmter gefährlicher Stoffe in Elektro- und Elektronikgeräten.

RMG Messtechnik GmbH
Butzbach, den 11.07.2023

Thorsten Dietz, Managing director

i.A.

Sascha Körner, Engineering Manager



1 **Translation**
EU-Type Examination Certificate

2 **Directive 2014/34/EU of the European Parliament and of the Council of 26 February 2014**

3 EU-Type Examination Certificate Number: **BVS 22 ATEX E 045 X** Issue: **00**

4 Equipment: **Process gas chromatograph type RGC7**-M**

5 Manufacturer: **RMG Messtechnik GmbH**

6 Address: **Otto-Hahn-Straße 5, 35510 Butzbach, Germany**

7 This product and any acceptable variations thereto are specified in the appendix to this certificate and the documents referred to therein.

8 DEKRA Testing and Certification GmbH, Notified Body number 0158, in accordance with Article 17 of Directive 2014/34/EU of the European Parliament and of the Council, dated 26 February 2014, certifies that this product has been found to comply with the Essential Health and Safety Requirements relating to the design and construction of products intended for use in potentially explosive atmospheres given in Annex II to the Directive.
 The examination and test results are recorded in the confidential Report No. BVS PP 22.2090 EU.

9 Compliance with the Essential Health and Safety Requirements has been assured by compliance with:

EN IEC 60079-0:2018 **General requirements**
EN 60079-1:2014 **Flameproof enclosure "d"**
EN IEC 60079-7:2015 + A1:2018 **Increased Safety "e"**

10 If the sign "X" is placed after the certificate number, it indicates that the product is subject to the "Specific Conditions of Use" listed under item 17 of this certificate.

11 This EU-Type Examination Certificate relates only to the technical design of the specified product in accordance to the Directive 2014/34/EU. Further requirements of the Directive apply to the manufacturing process and supply of this product. These are not covered by this certificate.

12 The marking of the product shall include the following:

 **II 2G Ex db eb IIB+H₂ T4 Gb**

DEKRA Testing and Certification GmbH
 Bochum, 2022-10-12

Signed: Dr. Rolf Krökel

Managing Director



Page 1 of 3 of BVS 22 ATEX E 045 X issue 00 – Jobnumber A 20210985 / 342474300
 This certificate may only be reproduced in its entirety and without any change.

DEKRA Testing and Certification GmbH, Handwerkstr. 15, 70565 Stuttgart, Germany
 Certification body: Dinnendahlstr. 9, 44809 Bochum, Germany
 Phone +49.234.3696-400, Fax +49.234.3696-401, e-mail DTC-Certification-body@dekra.com



13 **Appendix**
 14 **EU-Type Examination Certificate**
BVS 22 ATEX E 045 X issue 00

15 **Product description**

15.1 **Subject and type**

Process gas chromatograph type RGC 7**-M

Asterix	Description	Value
1	Carrier gas	0 Helium and Argon
		1 Helium
2	Measuring gas	1 Natural gas without H ₂
		3 Natural gas with max. 10 % H ₂
		4 Natural gas with max. 20 % H ₂
		7 Gas with max 90 to 100 % H ₂

15.2 **Description**

The Process gas chromatograph type RGC 7**-M serves as analyser of normally non-explosive gaseous substances. The maximum oxygen content of combustible gas mixtures is 5 % and thus below the limiting oxygen concentration.

Helium or Argon is used as carrier gas.

For the electrical connection of the Process gas chromatograph a separately tested and certified terminal box type SA-141410 in type of protection Increased Safety "e" is used.

The analyser (thermal conductivity detector) together with other electrical is housed in a separately tested and certified enclosure type EJB-4B in type of protection Flameproof Enclosure "d".

Before start-up of the detector, it has to be ensured by purging with carrier gas, that no explosive gas mixture is contained in the analyser.

The Process gas chromatograph is included in the periodical pressure test of the system.

15.3 **Parameters**

15.3.1 Electrical parameters

Rated voltage (gas analyser)	DC	20 – 28	V
Rated current		6.25	A
Rated power (gas analyser)		75	W
Rated power (heater)		50	W
Rated power (control)		25	W
Maximum total power		150	W

15.3.2 Thermal parameters

Ambient temperature range $-20\text{ °C} \leq T_{\text{amb}} \leq 60\text{ °C}$



Page 2 of 3 of BVS 22 ATEX E 045 X issue 00 – Jobnumber A 20210985 / 342474300
 This certificate may only be reproduced in its entirety and without any change.

DEKRA Testing and Certification GmbH, Handwerkstr. 15, 70565 Stuttgart, Germany
 Certification body: Dinnendahlstr. 9, 44809 Bochum, Germany
 Phone +49.234.3696-400, Fax +49.234.3696-401, e-mail DTC-Certification-body@dekra.com



16 Report Number

BVS PP 22.2090 EU, as of 2022-10-12

17 Specific Conditions of Use

The process gas chromatograph type RGC 7**-M only serves the purpose for analysing normally non-explosive gaseous substances.

The maximum concentration of oxygen shall be below 5 % in the gas mixture.

Before power on the process gas chromatograph, the analyser shall be surely purged with the carrier gas.

18 Essential Health and Safety Requirements

Met by compliance with the requirements mentioned in item 9.

19 Remarks and additional information

Drawings and documents are listed in the confidential report.

We confirm the correctness of the translation from the German original.
In the case of arbitration only the German wording shall be valid and binding.

DEKRA Testing and Certification GmbH
Bochum, 2022-10-12
BVS-Kir/Mu A 20210985 / 342474300



Managing Director

83



Page 3 of 3 of BVS 22 ATEX E 045 X issue 00 – Jobnumber A 20210985 / 342474300
This certificate may only be reproduced in its entirety and without any change.

DEKRA Testing and Certification GmbH, Handwerkstr. 15, 70565 Stuttgart, Germany
Certification body: Dinnendahlstr. 9, 44809 Bochum, Germany
Phone +49.234.3696-400, Fax +49.234.3696-401, e-mail DTC-Certification-body@dekra.com

		<h2>IECEX Certificate of Conformity</h2>	
INTERNATIONAL ELECTROTECHNICAL COMMISSION IEC Certification System for Explosive Atmospheres <small>for rules and details of the IECEx Scheme visit www.iecex.com</small>			
Certificate No.:	IECEX BVS 22.0041X	Page 1 of 4	Certificate history:
Status:	Current	Issue No: 0	
Date of Issue:	2022-10-21		
Applicant:	RMG Messtechnik GmbH Otto-Hahn-Str. 5 35510 Butzbach Germany		
Equipment:	Process gas chromatograph type RGC 7**-M		
Optional accessory:			
Type of Protection:	Flameproof Enclosures "d", Increased Safety "e"		
Marking:	Ex db eb IIB+H₂ T4 Gb		
Approved for issue on behalf of the IECEx Certification Body:		Jörg Koch	
Position:		Head of Certification Body	
Signature: (for printed version)			
Date: (for printed version)		21.10.2022	
<ol style="list-style-type: none"> 1. This certificate and schedule may only be reproduced in full. 2. This certificate is not transferable and remains the property of the issuing body. 3. The Status and authenticity of this certificate may be verified by visiting www.iecex.com or use of this QR Code. 			
Certificate issued by:			
DEKRA Testing and Certification GmbH Certification Body Dinnendahlstrasse 9 44809 Bochum Germany		DEKRA On the safe side.	

		<h2 style="margin: 0;">IECEX Certificate of Conformity</h2>	
Certificate No.:	IECEX BVS 22.0041X	Page 2 of 4	
Date of issue:	2022-10-21	Issue No: 0	
Manufacturer:	RMG Messtechnik GmbH Otto-Hahn-Str. 5 35510 Butzbach Germany		
Manufacturing locations:	RMG Messtechnik GmbH Otto-Hahn-Str. 5 35510 Butzbach Germany		
<p>This certificate is issued as verification that a sample(s), representative of production, was assessed and tested and found to comply with the IEC Standard list below and that the manufacturer's quality system, relating to the Ex products covered by this certificate, was assessed and found to comply with the IECEx Quality system requirements. This certificate is granted subject to the conditions as set out in IECEx Scheme Rules, IECEx 02 and Operational Documents as amended</p>			
<p>STANDARDS : The equipment and any acceptable variations to it specified in the schedule of this certificate and the identified documents, was found to comply with the following standards</p>			
<p>IEC 60079-0:2017 Explosive atmospheres - Part 0: Equipment - General requirements Edition:7.0</p>			
<p>IEC 60079-1:2014-06 Explosive atmospheres - Part 1: Equipment protection by flameproof enclosures "d" Edition:7.0</p>			
<p>IEC 60079-7:2017 Explosive atmospheres - Part 7: Equipment protection by increased safety "e" Edition:5.1</p>			
<p>This Certificate does not indicate compliance with safety and performance requirements other than those expressly included in the Standards listed above.</p>			
<p>TEST & ASSESSMENT REPORTS: A sample(s) of the equipment listed has successfully met the examination and test requirements as recorded in:</p>			
<p>Test Report: DE/BVS/ExTR22.0037/00</p>			
<p>Quality Assessment Report: DE/BVS/QAR08.0011/10</p>			



IECEX Certificate of Conformity

Certificate No.: **IECEX BVS 22.0041X**

Page 3 of 4

Date of issue: **2022-10-21**

Issue No: **0**

EQUIPMENT:
Equipment and systems covered by this Certificate are as follows:

General product information:

Subject and type
Process gas chromatograph type RGC 7**-M

Asterix	Description	Value
1	Carrier gas	0 Helium and Argon
		1 Helium
2	Measuring gas	1 Natural gas without H ₂
		3 Natural gas with max. 10 % H ₂
		4 Natural gas with max. 20 % H ₂
		7 Gas with max 90 to 100 % H ₂

Listing of all separately certified products used with older standards

Subject and type	Certificate	Standards
Empty flameproof enclosure type EJB-4B	IECEX CES 14.0017U iss. 01 ¹	IEC 60079-0:2011, Ed. 6.0 IEC 60079-1:2014, Ed. 7.0 IEC 60079-31:2013, Ed. 2.0
Terminal box type SA-141410	IECEX CES 13.0001 iss. 02 ¹	IEC 60079-0:2017, Ed. 7.0 IEC 60079-7:2015, Ed. 5.0 IEC 60079-11:2011, Ed. 6.0 IEC 60079-31:2013, Ed. 2.0
Bushing type NPS 38... or TP 38	IECEX CES 10.0003U iss. 02 ¹	IEC 60079-0:2011, Ed. 6.0 IEC 60079-1:2014, Ed. 7.0 IEC 60079-31:2013, Ed. 2.0

¹ No applicable technical differences

² Technical differences evaluated and found satisfactory

SPECIFIC CONDITIONS OF USE: YES as shown below:
The Process gas chromatograph type RGC 7**-M only serves the purpose for analysing normally non-explosive gaseous substances.

The maximum concentration of oxygen shall be below 5 % in the gas mixture.

Before power on the Process gas chromatograph, the analyzer shall be surely purged with the carrier gas.



IECEX Certificate of Conformity

Certificate No.: **IECEX BVS 22.0041X**

Date of issue: **2022-10-21**

Page 4 of 4

Issue No: 0

Equipment (continued):

Description

The Process gas chromatograph type RGC 7**-M serves as an analyser of normally non-explosive gaseous substances. The maximum oxygen content of combustible gas mixtures is 5 % and thus below the limiting oxygen concentration.

Helium or Argon is used as carrier gas.

For the electrical connection of the Process gas chromatograph a separately tested and certified terminal box type SA-141410 in type of Protection Increased Safety "e" is used.

The analyser (thermal conductivity detector) together with other electrical, is housed in a separately tested and certified enclosure type EJB-4B in Type of Protection Flameproof Enclosure "d".

Before start-up of the detector, it has to be ensured by purging with carrier gas, that no explosive gas mixture is contained in the analyser.

The Process gas chromatograph is included in the periodical pressure test of the system.

Parameters

Electrical parameters

Rated voltage (gas analyser)	DC	20 – 28	V
Rated current		6.25	A
Rated power (gas analyser)		75	W
Rated power (heater)		50	W
Rated power (control)		25	W
Maximum total power		150	W

Thermal parameters

Ambient temperature range	-20 °C ≤ T _{amb} ≤ 60 °C
---------------------------	-----------------------------------



Physikalisch-Technische Bundesanstalt
Nationales Metrologieinstitut

KBS

Konformitätsbewertungsstelle

88



Baumusterprüfbescheinigung

Type-examination Certificate

Ausgestellt für: <i>Issued to:</i>	RMG Messtechnik GmbH Otto-Hahn-Str. 5 35510 Butzbach	
gemäß: <i>In accordance with:</i>	Anlage 4 Modul B der Mess- und Eichverordnung vom 11.12.2014 (BGBl. I S. 2010) <i>Annex 4 Modul B of the Measures and Verification Ordinance dated 11.12.2014 (Federal Law Gazette I, p. 2010)</i>	
Geräteart: <i>Type of instrument:</i>	Gasbeschaffenheitsmessgerät <i>Device to determine the gas quality</i> Prozessgaschromatograph (PGC)	
Typbezeichnung: <i>Type designation:</i>	RGC 704	
Nr. der Bescheinigung: <i>Certificate No.:</i>	DE-21-M-PTB-0076	
Gültig bis: <i>Valid until:</i>	10.07.2033	
Anzahl der Seiten: <i>Number of pages:</i>	45	
Geschäftszeichen: <i>Reference No.:</i>	PTB-3.31-4107344	
Nr. der Stelle: <i>Body No.:</i>	0102	
Zertifizierung: <i>Certification:</i>	Braunschweig, 11.07.2023	Bewertung: <i>Evaluation:</i>
Im Auftrag <i>On behalf of PTB</i>	Siegel <i>Seal</i>	Im Auftrag <i>On behalf of PTB</i>
 Dr. Bert Anders		 Helga Bettin

Baumusterprüfbescheinigungen ohne Unterschrift und Siegel haben keine Gültigkeit. Diese Baumusterprüfbescheinigung darf nur unverändert weiterverbreitet werden. Auszüge bedürfen der Genehmigung der Physikalisch-Technischen Bundesanstalt.
Type-examination Certificates without signature and seal are not valid. This Type-examination Certificate may not be reproduced other than in full. Extracts may be taken only with the permission of the Physikalisch-Technische Bundesanstalt.

R3-0010

Contact

Subject to technical changes

More information

If you would like to receive more information about the products and solutions of RMG visit our website:

www.rmg.com

or contact your local sales representative

RMG Messtechnik GmbH

Otto-Hahn-Straße 5

35510 Butzbach, Germany

Phone: +49 (0) 6033 897 – 0

Fax: +49 (0) 6033 897 – 130

Email: service@rmg.com

