

RMG FLOW COMPUTER

RFC 7

Operating Manual

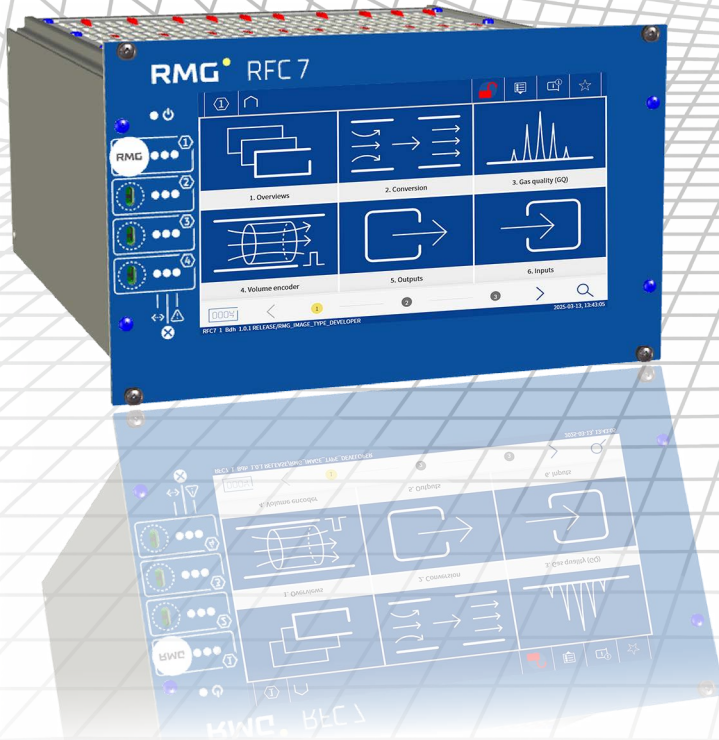
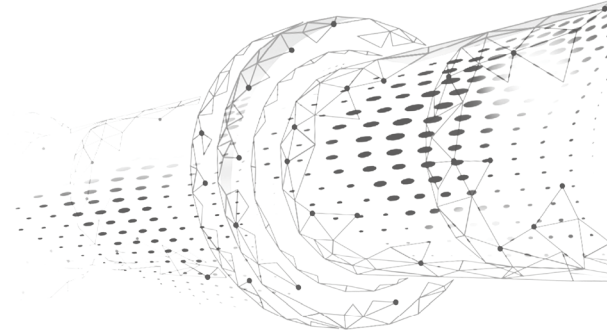

Contact details

Manufacturer information

Address: RMG Messtechnik GmbH
 Otto-Hahn-Straße 5
 D-35510 Butzbach

Phone, central: +49 6033 897-0
 Phone, service: +49 6033 897-897
 Phone, spare parts: +49 6033 897-897
 Fax: +49 6033 897-130
 Email: service@rmg.com
 Website: www.rmg.com

Document information

This document is a translation of the original German operating instructions.

We reserve the right to make changes to the content. Minor and editorial errors not caused by gross negligence or wilful misconduct shall not give rise to any liability or indemnification claims. RMG Messtechnik GmbH assumes that the documentation and operating instructions are used by competent personnel.

The latest version of this manual and the manuals of other devices can be downloaded conveniently from our website.

Version	Version date	Changes
V00	November 2024	Initial creation
V01	April 2025	Addition further contents
V02	April 2026	Addition further contents

Protection notice pursuant to DIN ISO 16016

Any transmission or reproduction of this document or exploitation or sharing of its content is prohibited unless expressly permitted. Any infringements shall result in liability for damages. All rights reserved in the event of patent, utility model or design registrations.

© RMG Messtechnik GmbH, 2024-2026

Preface

Dear Customer,

Thank you for deciding to purchase a product from RMG Messtechnik GmbH.

We would like to ask you to take the time to read this manual carefully, paying special attention to the safety information provided throughout the text and the section on 'safety information'.

This is essential for handling and working with the product safely.

Our products are continuously developed, so there may be some minor differences between the product you have received and the depictions provided in this operating manual.

If you have any questions that are not answered by this manual, please contact us; we will be happy to help.

If you have any suggestions for improvements we could make, please let us know.

RMG Messtechnik GmbH

Table of contents

Contact details	2
Preface	3
1 About this manual	8
1.1 Scope of the manual	8
1.2 Abbreviations	8
1.3 Symbols	9
1.4 Structure of the safety information	10
2 General information	11
2.1 Intended use	11
2.2 Foreseeable misuse	11
2.3 Liability disclaimer	12
2.4 Conformity	12
2.5 Type label	13
2.5.1 Nameplate, basic device	13
2.5.2 Nameplate, stream	14
2.6 Personnel qualifications	15
2.7 Responsibility of the owner	16
2.8 Scope of delivery	17
3 Safety information	18
3.1 Risk assessment and risk minimisation	18
3.2 General safety information	18
3.3 Safety information for installation and initial start-up	19
3.4 Safety information for normal operation	20
3.5 Safety information for servicing, maintenance and cleaning	20
3.6 Special types of hazard – explosion protection	21
4 Product description	22
4.1 Structure of the RFC 7	22
4.1.1 Housing variants	22
4.1.2 Front panel	24
4.1.3 Components in the housing	26
4.1.4 Components of a stream	27
4.1.5 Connections	28
4.2 Function of the RFC 7	30
5 Transport and storage	31
5.1 Inspection following delivery	31
5.2 Disposing of packaging material	31
5.3 Storing RFC 7	31
5.4 Transporting RFC 7	31
6 Installation	32
6.1 Mechanical installation	32

6.1.1	Place of installation and ambient conditions	32
6.1.2	Unit dimensions and weight	33
6.1.3	Installation	33
6.2	Electrical installation	34
6.2.1	Connections of the RFC 7	35
6.2.2	Terminal assignments of the terminal strips	36
6.2.3	Pin configuration of the serial interfaces Ser1 – Ser3 (RS-485)	41
6.2.4	Power supply and fuse protection	43
6.2.5	Connecting the temperature measurement	43
6.2.6	Connecting pressure measurement	46
6.2.7	Connecting mechanical gas meters	48
6.2.8	Connecting an ultrasonic gas meter	50
6.2.9	Connecting gas quality measurement device	51
7	User Interface Operation	53
7.1	Operation from the touchscreen	53
7.1.1	Structure of the menu pages (touchscreen)	54
7.1.2	Navigating between the menus	55
7.2	Operation from PC	57
7.2.1	Structure of the menu pages	58
7.2.2	Navigating between the menus	59
7.3	Controls in the header	60
7.3.1	User log-in	61
7.3.2	Set language	65
7.3.3	Messages	66
7.3.4	Favourites	67
7.4	Controls in the display field	68
7.5	Overview of the available menu pages	73
8	Commissioning	81
8.1	General commissioning instructions	81
8.2	Prerequisites for commissioning	82
8.3	Carrying out commissioning	82
8.3.1	Establishing a network connection	82
8.3.2	User login	87
8.4	Entering user data	88
8.4.1	Entering measurement location details	88
8.5	Volume conversion – defining parameters	89
8.5.1	Defining units	89
8.5.2	Defining formats	91
8.5.3	Gas pressure – defining parameters	93
8.5.4	Gas temperature – defining parameters	95
8.5.5	Flow rate – defining parameters	96
8.5.6	Flow rate at measured conditions – defining parameters	99
8.5.7	Corrected flow rate at measured conditions – defining parameters	100
8.5.8	Compressibility factor calculation – defining parameters	100
8.5.9	Flow rate at base conditions – defining parameters	104
8.5.10	Energy flow – defining parameters	106
8.5.11	Counter mode – defining parameters	106
8.6	Gas quality (GQ) – defining parameters	108

8.6.1	GQ setting	108
8.6.2	GQ lower and upper warning limits	111
8.6.3	GQ default values	112
8.6.4	Main GQ Modbus client	113
8.6.5	Backup GQ Modbus client	119
8.6.6	Main / backup GQ Modbus server	119
8.6.7	GQ DSfG	120
8.6.8	Main GQ DSfG	121
8.6.9	Backup GQ DSfG	121
8.7	Volume encoder – defining parameters	122
8.7.1	Meter factor	122
8.7.2	Characteristic curve	123
8.7.3	Modbus client for USM	125
8.7.4	Counter readings (Modbus client)	128
8.7.5	Synchronisation monitoring	129
8.8	Inputs – defining parameters	131
8.8.1	Digital inputs 1 and 2 – defining parameters	131
8.8.2	Analogue inputs – defining parameters	131
8.8.3	PT100 – defining parameters	133
8.8.4	Frequency and pulse input – defining parameters	135
8.8.5	Encoder settings	136
8.9	Outputs – defining parameters	137
8.9.1	Digital outputs – defining parameters	137
8.9.2	Analogue outputs – defining parameters	141
8.10	Check – carrying out a functional test	144
8.10.1	Freeze – defining parameters	144
8.10.2	Functional test – defining parameters and carrying out the test	145
8.10.3	Results of the functional test	147
8.11	System settings	148
8.11.1	Software update	149
8.11.2	Formatting the SD card	151
8.11.3	Customising the Modbus user list	152
8.11.4	DSfG settings	153
8.11.5	Downloading / importing the device configuration	157
9	Operation	161
9.1	Maximum load display and registration	161
9.2	Data storage in DSfG archives	163
9.3	Deleting archives	164
10	Maintenance and regular checks	165
11	Potential errors and repairs	166
11.1	Error messages	166
11.2	Repairs	166
12	Dismantling and disposal	167
12.1	Dismantling	167
12.2	Disposal	167
13	Technical data	168

Annex A	Lead seal plan	173
Annex A.1	Single-Stream variant	173
Annex A.2	Multi-Stream variant	174
Annex B	Declaration of conformity	175
Annex C	Approvals	176
Annex C.1	Measuring Instruments Directive 2014/32/EU – Volume conversion device for gas	176
Annex C.2	Measures and Verification Ordinance – Energy conversion device	177
Annex C.3	Measures and Verification Ordinance – Load Recorder and indicating device for the maximum load	178
Annex C.4	Directive 2014/34/EU – Electronic Assembly type IOC-Ex-IO	179

1 About this manual

The Flow Computer RFC 7 is a device from the universal device concept developed by RMG Messtechnik, referred to as the platform for 19" device technology.

This operating manual contains essential information on operating the Flow Computer RFC 7 safely, reliably and as intended.

It forms an integral part of the RFC 7 and must be kept close to the device in a place where it can be accessed by the personnel easily at any time.

The manual is intended for technically qualified personnel who have been trained for installation, operation, maintenance and repair.

The personnel must have carefully read and understood this manual before commencing any work. Compliance with all the specified safety information and instructions is essential for safe work.

Illustrations provided in this manual are intended to provide a general understanding and may not correspond precisely to the actual product.

1.1 Scope of the manual

This manual applies to the variants of the RFC 7 listed below:

- Single-Stream (one stream – data from one measurement point are processed in the RFC 7)
- Multi-Stream (two to four streams – data from up to four independent measurement points are processed in the RFC 7)

The above-mentioned variants are available in the following versions, with different software and parameterisation:

- -Vol: Volume corrector
- -Energy: Energy corrector

The Flow Computer RFC 7 is used as an individual component in an overall system. The manuals of the other components used therefore apply in addition to this manual. In the event of the manuals containing contradictory instructions, please contact RMG Messtechnik GmbH and/or the manufacturers of the other components.

NOTE

Information on the Multi-Stream version

The Multi-Stream version listed will only be released at a later date. At present, no devices of this variant are available.

1.2 Abbreviations

This manual uses the following abbreviations:

RFC	RMG Flow Computer
MID	Measurement Instruments Directive 2014/32/EU
PED	Pressure Equipment Directive 2014/68/EU

Table 1: Abbreviations

DVGW	D eutscher V erein des G as- und W asserfaches (German Association for Gas and Water)
ATEX	Explosion protection in accordance with ATEX Product Directive 2014/34/EU (A Tmosphères E Xplosives)
MessEG	M ess- und E ichgesetz (German Weights and Measures Act)
MessEV	M ess- und E ichverordnung (German Weights and Measures Ordinance)
PTB	P hysikalisch T echnische B undesanstalt (German National Metrology Institute)
CoM	C omputer o n M odule
IOC	I nput O utput C ontroller
GUI	G raphical u ser i nterface
DSfG	D igitale S chnittstelle für G asmessgeräte (Digital Interface for Gas Measurement Equipment)
TCP/IP	T ransmission C ontrol P rotocol/ I nternet P rotocol Family of network protocols (Internet protocol family)
IP (address)	Address based on the Internet protocol (IP) and assigned to devices in the network so that they can be addressed and accessed.
LAN	L ocal A rea N etwork – a local computer network.
Eth	Ethernet interface Ethernet technology enables data to be exchanged between connected devices in the local network.
SNTP	(S imple) standard (NTP = N etwork T ime P rotocol) for synchronising clocks in computer systems
SNR	S ignal to n oise ratio
VOS or SoS	S peed o f s ound
TD	T ransducer (ultrasonic transmitter and receiver)
USM (USZ)	Ultrasonic flowmeter
Vo	Original counter
ENCO	Encoder for digital transmission of the original counter
HART	H ighway A ddressable R emote T ransducer protocol: standardised digital communication superimposed over the 4–20 mA analogue signal for data exchange with transmitter devices

Table 1: Abbreviations

1.3 Symbols

This manual uses the following symbols:

1., 2., etc.	Indicates steps that are to be performed in the specified sequence.
▶	Indicates a measure or an activity that is to be carried out.
➔	Indicates the sequences of a performed measure or a step
▪	Indicates a general collection of information
	Indicates a reference to a specific section of this manual

Table 2: Symbols used

1.4 Structure of the safety information

In this manual, safety information is labelled with symbols and introduced with signal words.

The safety information specifies the type and the source of the danger and describes the consequences of failing to observe the safety information.

The safety information concludes by describing the measures and actions required to avoid the hazard.

The safety information in this manual is structured as follows:

⚠ DANGER

Imminent threat

Potential consequences of failing to observe the safety information: death or extremely severe injury

- ▶ Preventive measure or action
-

⚠ WARNING

Dangerous situation

Potential consequences of failing to observe the safety information: severe or irreversible injury

- ▶ Preventive measure or action
-

⚠ CAUTION

Potentially dangerous situation

Potential consequences of failing to observe the safety information: slight or minor injury

- ▶ Preventive measure or action
-

NOTE

Warning of property damage, and instructions for use

Instructions for use and useful or important information

2 General information

2.1 Intended use

The Flow Computer RFC 7 is used to collect and evaluate signals and measurements from gas meters and gas analysis devices and from pressure and temperature sensors from up to four measurement points in order to determine standard flow rates and energy volumes, for example. The measurement results and calculated output variables can be monitored and archived with the RFC 7. It can be used in a variety of applications, as:

- Volume corrector to determine the K number¹⁾ and the volume at base conditions of gas mixtures such as natural gas and biogas (version: -Vol)
- Calorific value corrector to determine the K number¹⁾ and the volume at base conditions and, in combination with the calorific value, the gas quality in order to determine the energy content of gas mixtures such as natural gas and biogas (version: -Energy)

¹⁾ Compressibility coefficient: correction factor for the difference between how the gas behaves in the actual situation at hand and the ideal gas behaviour

When the device is placed on the market for the first time, the settings that are required for approval in applications involving official calibration are made before delivery and secured against substantial alteration with lead seals and software and hardware locking.

The Flow Computer RFC 7 is **not** intended for use in potentially explosive atmospheres. Nevertheless, devices and sensors may be connected to the RFC 7 that are located in a potentially explosive atmosphere.

The RFC 7 was designed and manufactured in accordance with the latest technological developments and recognised safety standards and guidelines. Nevertheless, hazards or damage to the device or other property may occur during its use. The RFC 7 may only be used as intended as in a perfect technical condition.

Observe the operating manual and follow the instructions and installation, start-up, operation and maintenance guidelines.

Perform cleaning and care of the device on a regular basis and observe the guidelines for wearing personal protective equipment (e.g. safety helmet, safety goggles, safety boots).

2.2 Foreseeable misuse

Foreseeable misuse refers to any use for purposes other than those named above, in particular:

- Personnel who have not been given instructions engaging in activities on the device.
- Failure to follow the operating instructions issued by the owner.
- Failure to observe the operating manual.
- Using the RFC 7 in a potentially explosive atmosphere.
- Removing or damaging the lead seals or software or hardware locks in devices intended for applications involving official calibration.
- Unauthorised changes being made to the device settings, especially in the case of devices used for applications involving official calibration.

NOTE**Use other than as intended**

Use other than as intended voids any guarantee claims and the Flow Computer RFC 7 may lose its approvals.

2.3 Liability disclaimer

All specifications and notes provided in this manual were compiled in accordance with the application standards and guidelines, the latest technological developments and many years of knowledge and experience.

RMG Messtechnik GmbH assumes no liability for loss or damage caused by:

- failure to observe this manual
- use other than as intended
- deployment of untrained personnel
- operating errors
- unauthorised modifications
- technical alterations
- use of non-permitted spare parts

The obligations arranged in the supply agreement, the general terms and conditions and the statutory regulations that applied at the time the agreement was concluded apply.

2.4 Conformity

The Flow Computer RFC 7 was approved and placed on the market in accordance with the following directives:

- Measurement Instruments Directive 2014/32/EU
- EMC Directive 2014/30/EU
- RoHS Directive 2011/65/EU

Variants of the RFC 7 that have an input card that enables the secure separation of signals of intrinsically safe field devices (Ex-i) are also approved and placed on the market in accordance with the following directive:

- ATEX Directive 2014/34/EU

For operation in applications involving official calibration in Germany, approval is being sought in accordance with the following laws and regulations:

- German Weights and Measures Act (MessEG) – dated 25 July 2013
- German Weights and Measures Ordinance (MessEV) – dated 11 Dec. 2014

In accordance with the individual device variants, the required harmonised standards have been applied. The following list contains all standards that could be applied:

- EN ISO 6976:2016
- DIN EN 12405-1:2021
- DIN EN 12405-2:2012
- DIN EN 12405-3:2015
- EN IEC 61000-6-2:2019

- EN IEC 61000-6-4:2019
- EN IEC 61000-4-2:2009
- EN 60068-2-2:2007
- EN 60068-2-78:2013
- EN 60068-2-30:2005
- EN IEC 60079-0:2018
- EN 60079-11:2012
- DIN EN 60751/IEC 751

The EU declaration of conformity is provided in the annex.

The device bears the following mark:



Devices that also have ATEX directive approval bear the following additional mark:



IIC-Ex-IO
 II (2)G [Ex ib Gb] IIC
 BVS 23 ATEX E 027 X, IECEx BVS 23.0017X
 T_a = -25 °C to +60 °C

For queries or for additional information, please contact RMG Messtechnik GmbH.

2.5 Type label

Depending on the approval, number of streams and intended function, the Flow Computer RFC 7 is given various nameplates, which are arranged on the front panel. The nameplates can fundamentally be split into two types:

- Nameplate, basic device RFC 7
- Nameplate for each stream

2.5.1 Nameplate, basic device

Depending on the version, the basic device RFC 7 is given the following nameplates (examples).

Approval in accordance with Measuring Instruments Directive (MID)

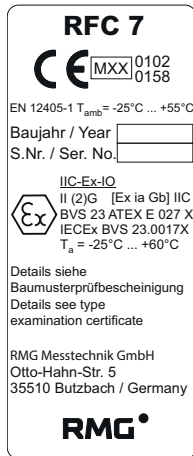

Fig. 1: Name plate with Ex equipment (example)

Approval in acc. with MessEG and MesseV

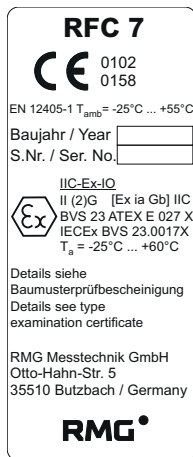

Fig. 2: Name plate with Ex equipment (example)

2.5.2 Nameplate, stream

In accordance with the completed approval and the function, each stream is given the nameplates listed below (examples).

Approval in accordance with Measuring Instruments Directive (MID)

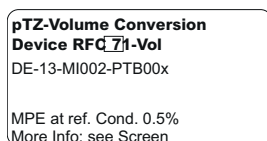

Fig. 3: Nameplate, condition volume corrector (stream 1, example)

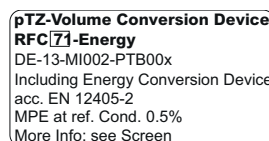

Fig. 4: Nameplate, calorific value volume corrector (stream 1, example)

Approval in acc. with MessEG and MessEV

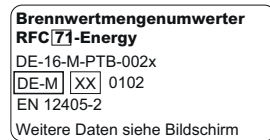

Fig. 5: Nameplate, calorific value volume corrector (stream 1, example)

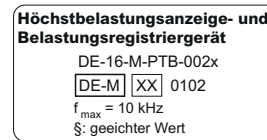

Fig. 6: Nameplate, peak load display and load registration device (stream 1, example)

2.6 Personnel qualifications

DANGER

Danger of death arising from insufficiently qualified personnel

If unqualified personnel perform work such as mechanical and/or electrical installation, and in initial start-up, in potentially explosive atmospheres hazards arise that could cause extremely severe injury or death.

- ▶ All activities must only be performed by personnel who have received training and instruction for work in potentially explosive atmospheres.
- ▶ Keep unqualified personnel away from the hazard zones.
- ▶ Have any work that has been performed checked by responsible experts.
- ▶ Mechanical installation must also only be performed by persons with the corresponding qualifications, who have the knowledge required for the activities to be performed and the tools to be used.

NOTE

Recommend qualifications for the personnel

In general the following qualifications are recommended for all persons working with or on the Flow Computer RFC 7:

- ▶ Education/training relating to work in potentially explosive atmospheres.
- ▶ Ability to correctly assess hazards and risks in handling the RFC 7 and all connected devices.
- ▶ Education/training provided by RMG Messtechnik GmbH for work with gas measuring instruments.
- ▶ Training/instruction in relation to all national standards and guidelines that need to be complied with for the work to be performed at the RFC 7.

The following personnel qualifications have been defined for the various activities in involving the RFC 7:

- Operation: The operating personnel use and operate the device within the scope of its intended use. The owner instructs the operating personnel regarding the tasks assigned to them and potential dangers.
- Cleaning and care: Cleaning and care of the device must only be performed by specialists with the corresponding qualifications.

Maintenance and repair:	Maintenance and repair work must only be performed by specialists who have received training from RMG in relation to the advanced operation and parameterisation of the device and the performance of preventive maintenance work. They are also able to perform the tasks assigned to them as the result of their specialist training and experience and knowledge of the relevant standards and provisions. These specialists are aware of the applicable legal regulations concerning accident prevention and are able to recognise and avoid potential hazards.
Installation and Electrical work:	Installation and electrical work must only be performed by a specialist electrician. A specialist electrician must have a specialist training, knowledge and experience in electrical engineering and be aware of the relevant standards and regulations (DIN VDE 0105, IEC 364, etc.). The specialist electrician is aware of the applicable legal regulations concerning accident prevention and is able to recognise and avoid potential hazards.

2.7 Responsibility of the owner

The device is used in the industrial sector. The owner of the device is therefore subject to the legal obligations relating to occupational health and safety.

In addition to the safety information provided in this manual, the safety, accident prevention and environmental regulations that apply to the device's field of application must be observed.

The following also applies in particular:

- As owner, ensure that only personnel with sufficient qualifications work on the device.
- Ensure that all employees who handle the device have read and understood this manual.
- Furthermore, you are obliged to train the personnel on a regular basis and to inform them of the risks and hazards involved in handling the device.
- Arrange for work performed by qualified personnel to be checked by responsible specialists.
- Clearly specify the responsibilities for installation, operation, troubleshooting, maintenance and cleaning.
- Make the required personal protective equipment available to the personnel.

2.8 Scope of delivery

The actual scope of delivery may differ from the explanations and depictions provided here in the case of custom designs or additional options being ordered or because of recent technical developments.

Nevertheless, the following table depicts the standard scope of delivery:

Component	Quantity
Flow Computer RFC 7	1
Connector set, complete	1
Operating manual	1

Table 3: Scope of delivery



For further information on the variants, see section 4 'Product description'.

3 Safety information

3.1 Risk assessment and risk minimisation

The RFC 7 was manufactured in accordance with the latest technical developments and recognised safety rules and standards, but its use does nevertheless pose some risks. Throughout the development process, these risks were identified and assessed by qualified employees. A corresponding risk analysis was compiled and used as a basis for developing and implementing structural measures in order to minimise the risks.

This manual draws attention, through safety information and instructions, to any remaining residual risks.

3.2 General safety information

⚠ DANGER

Danger – personal injury and property damage!

Failing to observe the safety information may result in danger to human life or health and environmental and property damage.

- ▶ Observe all the following safety information!

Bear in mind that the safety information in this manual and on the device is not able to cover all potential hazardous situations, as it is not possible to foresee how all the ways in which different circumstances may interact.

Exclusively observing the instructions provided may not be sufficient to ensure proper operation.

- ▶ Always remain attentive and think for yourself.
- ▶ Before working with the device for the first time, read this operating manual carefully, especially the safety information it contains.
- ▶ This operating manual provides warnings of unavoidable residual risks for users, third parties, devices and other property in its safety information.
- ▶ Only operate the device in a perfect technical condition, in compliance with the operating manual and in accordance with its intended use.
- ▶ In addition, observe the local legal regulations concerning accident prevention, installation and assembly.

NOTE**Applications involving official calibration**

If the Flow Computer RFC 7 is to be used for applications involving official calibration, it will be preset before delivery in accordance with the approval and secured with lead seals, software and hardware locks to prevent unauthorised alteration. If these protective measures are removed or damaged, the RFC 7 will lose its approval and may no longer be used in applications involving official calibration.

- ▶ Never remove or damage the lead seals or other protective measures!
- ▶ If a protective measure is removed or damaged, however, the device must be inspected by a state-approved body or a calibration official and the further settings must also be checked at the factory. The calibration official must reseal the opened lead seals to enable the RFC 7 to be used for applications involving official calibration once again.

3.3 Safety information for installation and initial start-up

⚠ DANGER**Risk of explosion arising from unauthorised installation of the RFC 7 in potentially explosive atmospheres**

The Flow Computer RFC 7 is **not** approved or designed for use in potentially explosive atmospheres. Using the RFC 7 in a potentially explosive atmosphere could, for example, cause it to become an ignition source as the result of sparking and trigger an explosion.

- ▶ Do not install the RFC 7 in a place where there is a potentially explosive atmosphere.
- ▶ Only install the RFC 7 in its original, complete and fault-free condition.
- ▶ Equalise the potential of the housing by connecting an earthing cable to the housing.
- ▶ When connecting auxiliary devices and sensors in potentially explosive atmospheres, ensure that corresponding explosion protection is provided for these components.
- ▶ For intrinsically safe components, provide secure isolation if they are connected to the RFC 7.
- ▶ Only allow devices and sensors to be connected to the RFC 7 by specialist personnel in accordance with EN 60079-14, in accordance with national regulations.
- ▶ Initial start-up must only be carried out by expert personnel or by RMG service personnel.
- ▶ To clean the housing, always use a slightly damp cloth to avoid static charging as the result of friction.

⚠ CAUTION**Danger – cutting injury**

Although all sharp edges on the device have been removed as far as possible, there is a risk of minor cutting injuries.

- ▶ Wear appropriate personal protective equipment when performing any work on the device.
 - ▶ Remove any burs that are still present on the device or on fastening points.
-

3.4 Safety information for normal operation

As a basic rule, the instructions of the owner of the system in which the RFC 7 is installed must be observed.

In addition, the safety information listed below must be observed:

⚠ WARNING**Risk of injury arising from incorrect operation**

Incorrect operation or modifications being made to the Flow Computer may give rise to hazards that could cause severe injury.

- ▶ Read this operating manual carefully to avoid incorrect operation and only use the RFC 7 in accordance with its intended use (see section 2.1 "Intended use").
 - ▶ For safe operation, observe the power limits specified in the technical data (see section 13 "Technical data") and ensure that they are not exceeded.
 - ▶ Do not use the Flow Computer as a step to climb on or as a handrail to steady yourself with!
-

3.5 Safety information for servicing, maintenance and cleaning

Service and maintenance work or repairs that are not described in this operating manual must not be carried out without prior consultation with the manufacturer.

Tampering with or modifying the Flow Computer in ways not described in this operating manual is not permitted.

⚠ DANGER**Danger of death arising from electrical voltage**

Before servicing, maintenance and cleaning work, it is essential to switch off the device or disconnect it from the mains power supply. Failing to do so may lead to extremely severe injury or death.

- ▶ Before any work is commenced, switch off the device's power supply or disconnect it from the mains.
 - ▶ Only carry out work on the device as described in this manual. Ensure that the device is not live while the work is being performed.
-

⚠ WARNING

Risk of injury arising from inappropriate servicing, maintenance and cleaning

If servicing, maintenance or cleaning work is performed incorrectly or if use of the device is resumed despite it being defective, damaged or unsafe, this may result in severe injury.

- ▶ Arrange for servicing, maintenance and cleaning work to be performed exclusively by specialists who have the required knowledge for the activities to be performed and the tools to be used.
- ▶ If a device is damaged or unsafe, it must be removed from circulation immediately and labelled accordingly to prevent it from being used accidentally.
- ▶ In general, it is recommended to have repairs or the exchange of a defective device performed only by RMG Service.

3.6 Special types of hazard – explosion protection

The Flow Computer RFC 7 is **not** approved or designed for use in potentially explosive atmospheres. However, auxiliary devices and sensors connected to the RFC 7 may be installed in potentially explosive atmospheres.



This symbol warns you of an explosive atmosphere; observe the information provided next to the symbol.

⚠ DANGER

Risk of explosion during installation and operation of devices and sensors in potentially explosive atmospheres

If devices and sensors connected to the RFC 7 are installed and operated in a potentially explosive atmosphere, even very low levels of ignition energy can result in an explosion that could cause extremely severe injury and death.

- ▶ Observe all applicable national regulations for installing devices and sensors in potentially explosive atmospheres (e.g. IEC 60079-10, IEC 60079-14, IEC 80079-20-1).
- ▶ When connecting auxiliary devices and sensors in potentially explosive atmospheres, ensure that corresponding explosion protection is provided for these components.
- ▶ For intrinsically safe components, provide secure isolation if they are connected to the RFC 7.
- ▶ Check the safety data of the RFC 7 and the connected intrinsically safe components and log the check in a corresponding Verification of Intrinsic Safety document.

4 Product description

The device concept – the platform – is a universal system intended to cover a large number of application cases and the connection of all individual RMG Messtechnik devices.

The Flow Computer RFC 7, as a volume corrector and an individual device from the platform, is available in the following variants:

- Single-Stream (one stream – data from one measurement point are processed in the RFC 7)
- Multi-Stream (two to four streams – data from up to four independent measurement points are processed in the RFC 7)

A **stream** means that the signals and measurement data of one measurement point are measured, registered, saved, converted and output. Each stream has its own hardware, but all streams share the same touchscreen and the power supply from the power pack. The individual streams are designated as follows:





Designation	Design	Display on the touchscreen
RFC 71	Flow Computer Stream 1	
RFC 72	Flow Computer Stream 2	
RFC 73	Flow Computer Stream 3	
RFC 74	Flow Computer Stream 4	

Table 4: Designation of the individual streams

NOTE

Information on the Multi-Stream version

The Multi-Stream version listed will only be released at a later date. At present, no devices of this variant are available.

4.1 Structure of the RFC 7

4.1.1 Housing variants

The RFC 7 is a Flow Computer that is encased in the housing of the following sizes, in accordance with the chosen number of streams:

- 19" housing for 1–2 streams, cf. fig. 7
- 19" housing for 3–4 streams, cf. fig. 8

Both sizes comprise the housing itself (no. 3), a housing cover (no. 1) with venting slits, a housing base (no. 4), a front panel for control (no. 5) and a back panel with connections (no. 2).

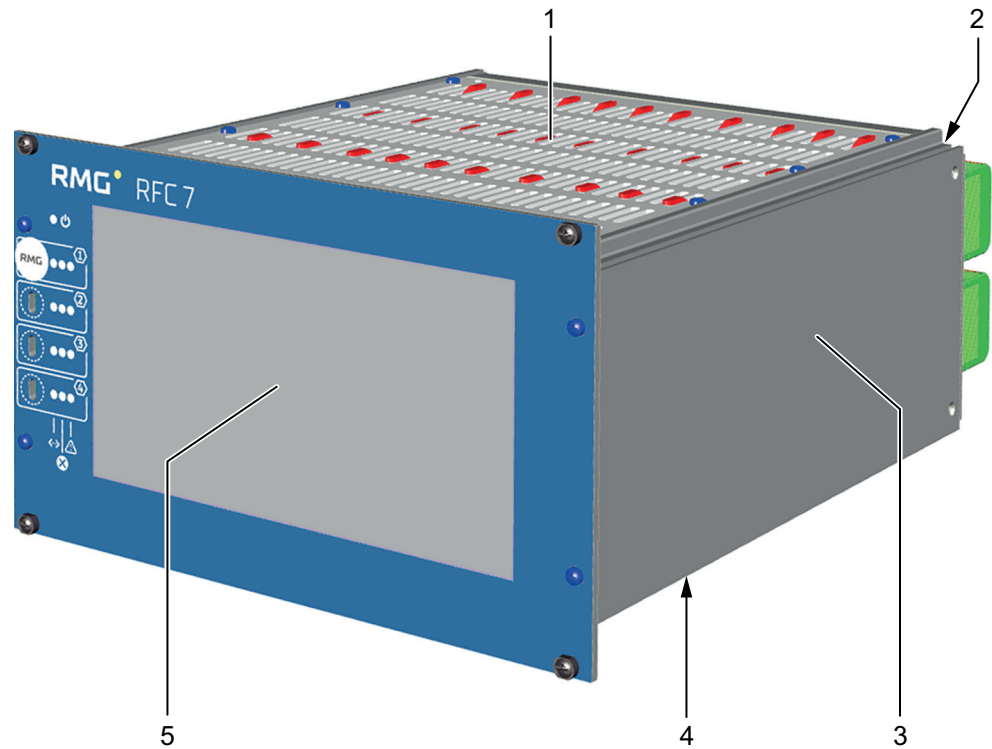

Fig. 7: RFC 7 – 19" housing for 1 to 2 streams

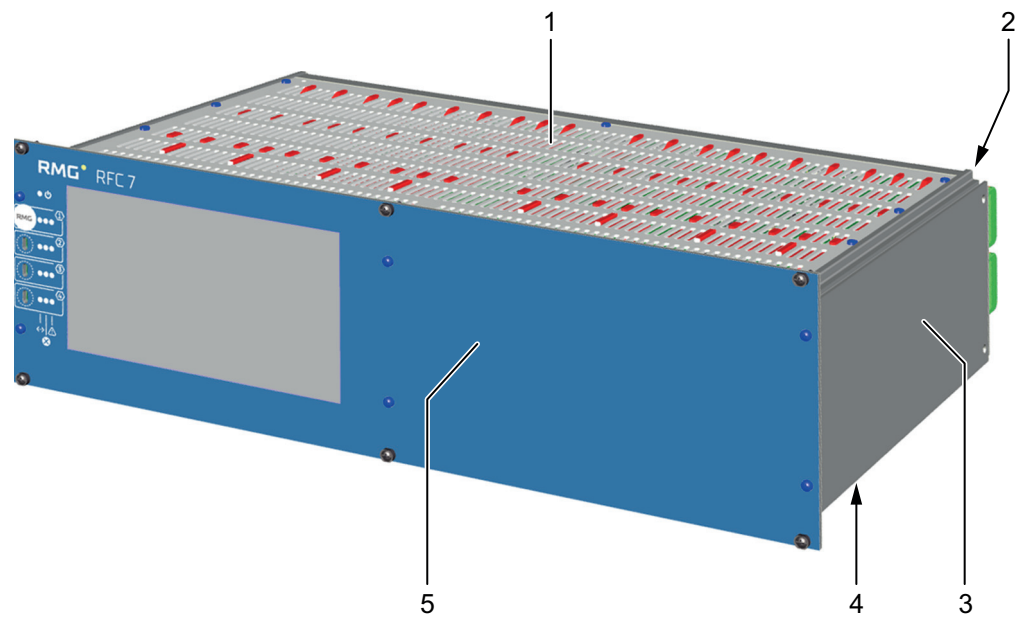

Fig. 8: RFC 7 – 19" housing for 3 to 4 streams

No.	Designation	No.	Designation
1	Housing cover with venting slits	2	Rear panel with connections
3	19" housing	4	Housing base
5	Front panel		



For the precise dimensions of both housing variants, please refer to section 6.1.2 "Unit dimensions and weight" or section 13 "Technical data".

4.1.2 Front panel

The front panels of both housing variants comprise:

- 7" touchscreen (1x)
- Status LEDs (3x) and calibration switch (1x) for each stream
- LED power supply (1x)

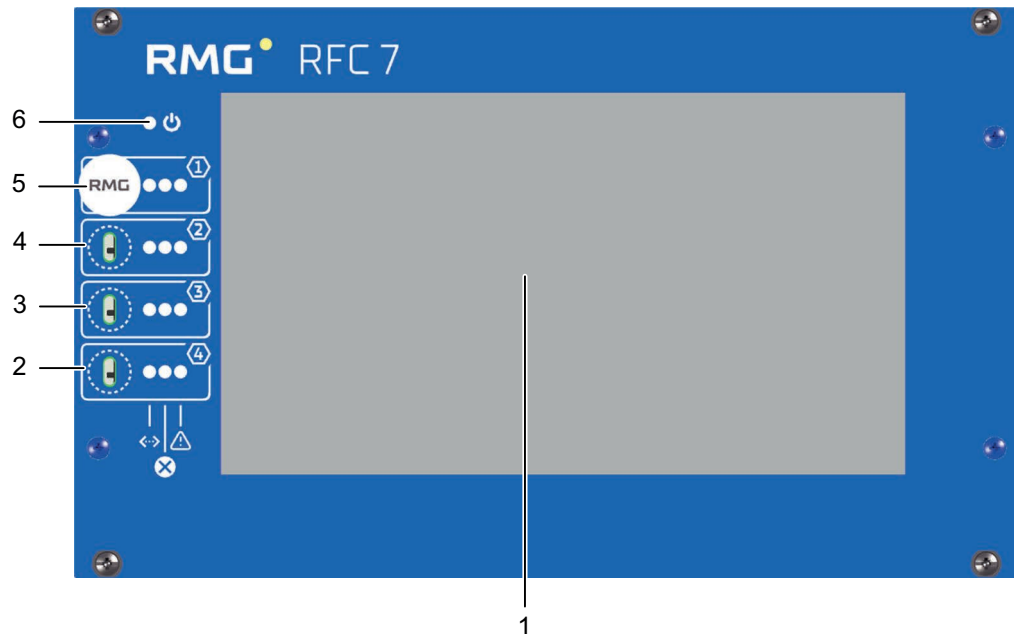

Fig. 9: Front panel RFC 7 – ½ 19" housing

No.	Designation	No.	Designation
1	7" touchscreen	2	Status LEDs and calibration switch for stream 4
3	Status LEDs and calibration switch for stream 3	4	Status LEDs and calibration switch for stream 2
5	Status LEDs and calibration switch for stream 1	6	LED power supply on (blue)

Each stream has its own calibration switch a separate status LEDs that signal the following operating statuses:

- Measurement in progress (green), cf. fig. 10, no. 1
- Warning (yellow), cf. fig. 10, no. 2
- Alarm/error/fault (red), cf. fig. 10, no. 3

The calibration switch (cf. fig. 10, no. 4) is used to lock the official calibration settings that have been set for the corresponding stream. It can be moved up and down in a vertical direction by means of an additional tool and is secured with a calibration seal (lead seal) for official calibration applications.

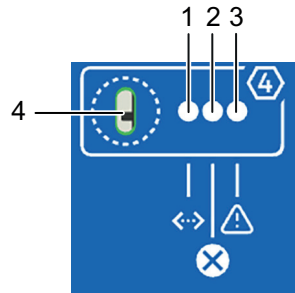

Fig. 10: Status LEDs and calibration switch, example for stream 4

No.	Designation	Function
1	Measurement in progress LED (green)	<ul style="list-style-type: none"> ■ Lights up continuously: measurement in progress
2	Warning LED (yellow)	<ul style="list-style-type: none"> ■ Lights up continuously: There is a warning.
3	Error/fault LED (red)	<ul style="list-style-type: none"> ■ Not lit up: There is no error/fault ■ Flashing: There is a current error/fault ■ Lights up continuously: There has been an error/fault
4	Calibration switch	<ul style="list-style-type: none"> ■ Locking of the official calibration parameters and functions. The calibration switch can be moved up and down by means of an additional tool. <p>The position of the calibration switch also indicates its operating state:</p> <ul style="list-style-type: none"> - Down: Calibration switch open - Up: Calibration switch closed



The status of the calibration switch is also displayed on the touchscreen interface and the web interface of a PC. For detailed information on this, please refer to the section 7.3.1 "User log-in".

4.1.3 Components in the housing

Regardless of the number of streams, each housing variant contains a power pack (24 V DC). The multi-stream variants also contain an intercom circuit board. The components for each stream are arranged side by side in the housing – cf. fig. 11 and fig. 12.

Each stream has the same components, i.e. identical hardware, as described in detail in the following section, 4.1.4 "Components of a stream".

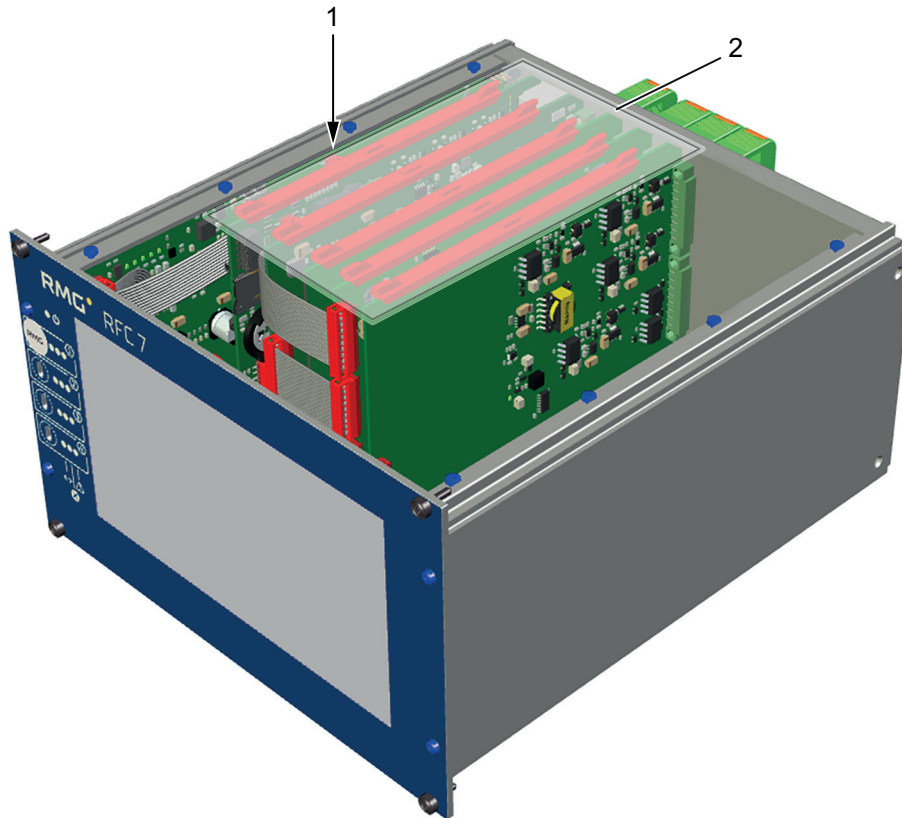

Fig. 11: Single-Stream: arrangement of components for one stream in the housing

No.	Designation	No.	Designation
1	Power pack 24 V DC	2	Stream unit

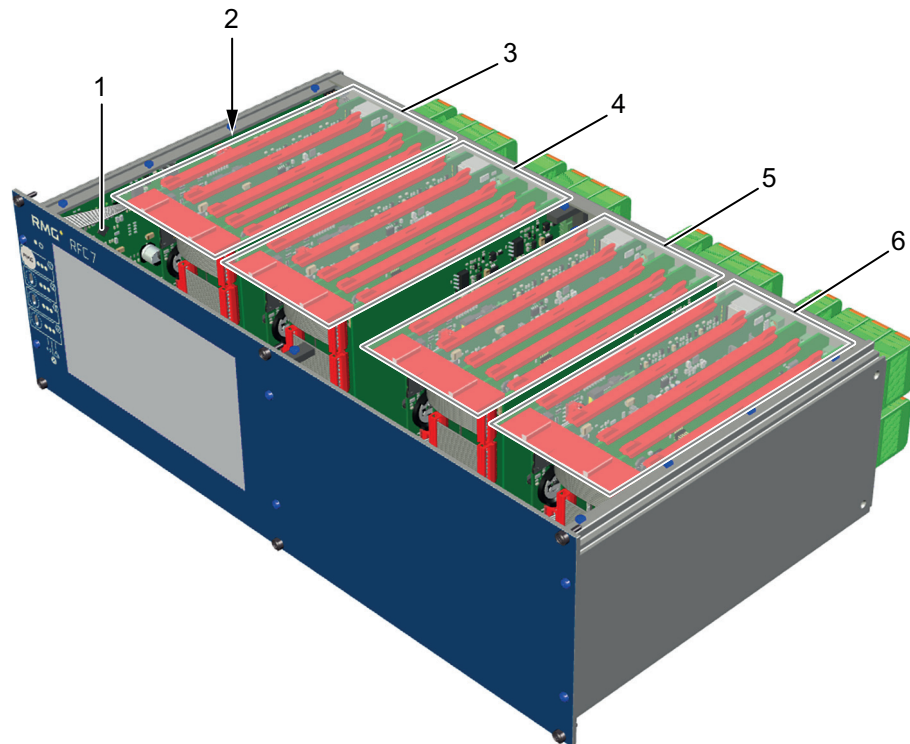

Fig. 12: Multi-Stream: arrangement of components for four streams in the housing

No.	Designation	No.	Designation
1	Intercom	2	Power pack 24 V DC
3	Stream unit 1	4	Stream unit 2
5	Stream unit 3	6	Stream unit 4

4.1.4 Components of a stream

The hardware (components) of a stream comprise a total of five plug-in circuit boards, which fulfil different functions:

- **CoM-Basis** for communication and computing (fig. 13, no. 1)
- **IO-System** comprising the following circuit boards:
 - **IOC-EX-IO** as interface to Ex zone with securely separated inputs and outputs (fig. 13, no. 2)
 - **IOC-Digital-IO** as interface for digital inputs and outputs outside of the Ex zone (fig. 13, no. 3)
 - **IOC-CPU** to process all analogue and digital inputs and outputs (fig. 13, no. 4)
 - **IOC-Analog-Out** as interface for analogue outputs outside of the Ex zone (fig. 13, no. 5)

With these plug-in circuit boards, all the intended functions can be executed. The hardware is not designed for expansion with plug-in circuit boards for additional functions.

The **CoM-Basis** (Computer on Module) is used for communication, including with a web server, provides the computing power for the volume conversion and manages archives.

The **IO-System** manages the entire measurement technology with actuators and sensors.

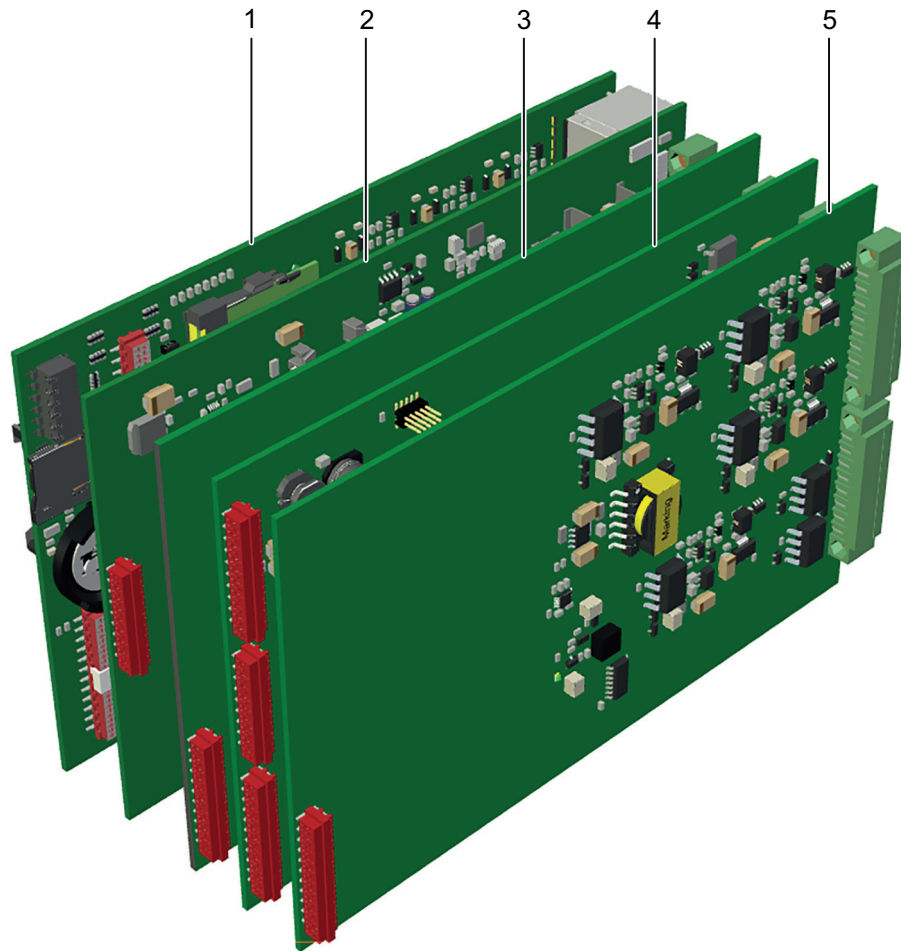

Fig. 13: Components of a stream (view from front)

No.	Designation	No.	Designation
1	CoM-Basis	2	IOC-EX-IO
3	IOC-Digital-IO	4	IOC-CPU
5	IOC-Analog-Out		

4.1.5 Connections

The connections of the RFC 7 are located on the device back panel. Each variant, Single- or Multi-Stream, has the following connections (cf. fig. 14 and fig. 15):

Power pack connections:

- Power supply 24 V DC
- USB port (not for use for official calibration applications, as lead-sealed)
- Fuse

Connections per stream (COM-Basis and IO-System):

- 5 analogue inputs, with 2 analogue inputs securely separated
- 4 analogue outputs
- 2 alarm and 2 warning outputs (comprising one NO and one NC in each case)
- 4 digital inputs, with 2 pulse inputs
- 6 digital outputs, with 4 pulse outputs
- 2 pulse inputs (reed/Namur) and 1 encoder input, securely separated

- 4-conductor connection for PT100, securely separated
- 3 serial interfaces RS485
- 4 Ethernet ports

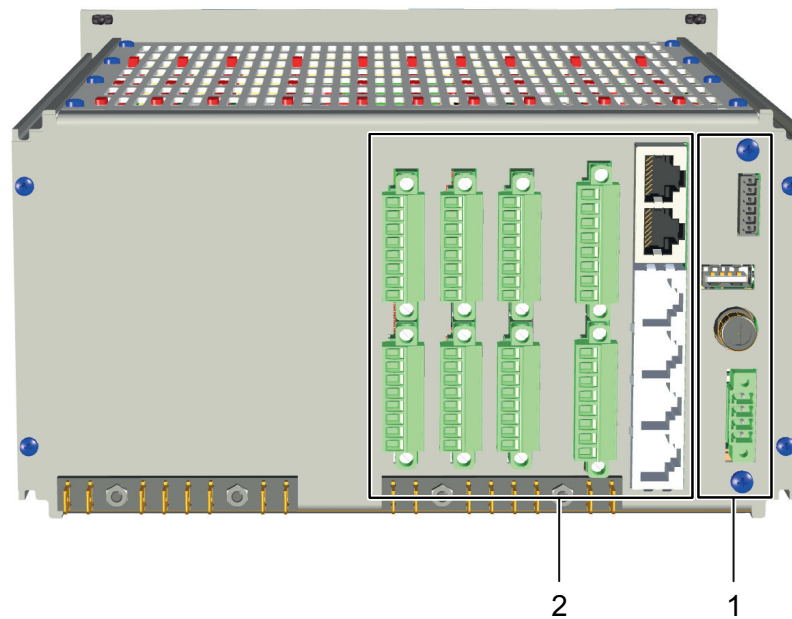

Fig. 14: Single-Stream: arrangement of connections on the back panel

No.	Designation	No.	Designation
1	Power pack connections	2	Connections and terminal strips, stream 1

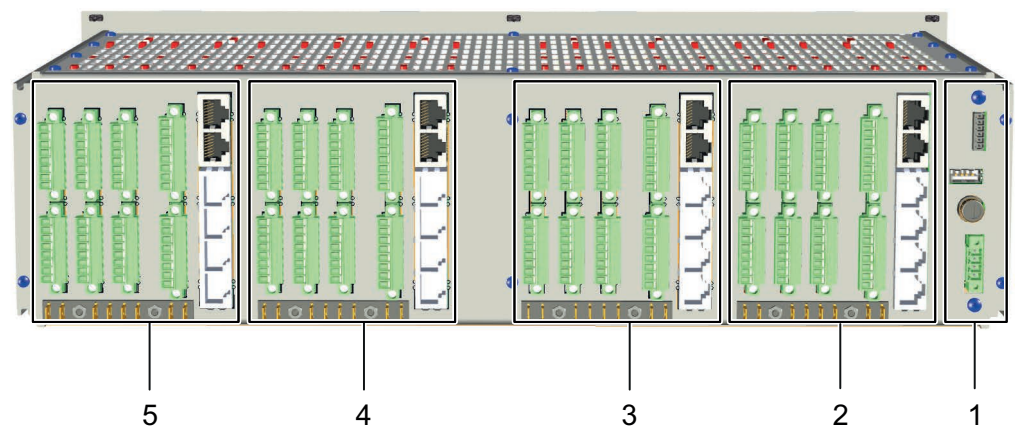

Fig. 15: Multi-Stream: arrangement of connections on the back panel

No.	Designation	No.	Designation
1	Power pack connections	2	Connections and terminal strips, stream 1
3	Connections and terminal strips, stream 2	4	Connections and terminal strips, stream 3
5	Connections and terminal strips, stream 4		



For the assignment of the individual terminal strips and additional information on the connection options, please refer to section 6.2 "Electrical installation".

4.2 Function of the RFC 7

The Flow Computer RFC 7 fulfils the following three key functions:

- Collecting the measurement data of gas meters, gas analysis devices and pressure and temperature sensors and monitoring the collection of measurement data.
- Processing the measurement data and calculating process variables such as standard flow rate, K number and energy volumes on the basis of appropriate calculation methods for various gas models.
- Archiving and outputting the measurement values and calculates process variables / depicting them in graphic form, and setting alarm and warning messages when limits are breached.

Depending on the connected devices and the recorded measurement data, the Flow Computer can be used with different software and parameterisation for the following applications:

- -Vol: Volume corrector to determine the K number¹⁾ and the volume at base conditions of gas mixtures such as natural gas and biogas
- -Energy: Calorific value corrector to determine the K number¹⁾ and the volume at base conditions and, in combination with the calorific value, the gas quality in order to determine the energy content of gas mixtures such as natural gas and biogas

¹⁾Compressibility coefficient: correction factor for the difference between how the gas behaves in the actual situation at hand and the ideal gas behaviour.

To calculate the K number, the following calculation methods are available in both applications:

- k = constant
- Complete analysis:
 - AGA 8 DC92
 - AGA 8:2017
 - GERG-2004
 - GERG-2008
- Gross values:
 - GERG-88 S
 - GERG-88 S Set B
 - GERG-88 S Set C
 - AGA NX-19 L
 - AGA NX-19 H
 - AGA Gross Meth. 1
 - AGA Gross Meth. 2
 - SGERG-mod-H2
- Pure substances:
 - Van der Waals
 - Beattie & Bridgeman



For a detailed description of operation, the individual menus of the user interface and the options for setting parameters, please refer to section 7 "User Interface Operation" and section 8 "Commissioning".

5 Transport and storage

5.1 Inspection following delivery

The Flow Computer RFC 7 is delivered in packaging that meets the customer's specific transport requirements. Nevertheless, the delivery should first be checked for completeness and damage. The device must be removed from its packaging for this check. The device is then installed (see section 6 "Installation") or placed in storage (see section 5.3 "Storing RFC 7").

- ▶ If damage has occurred, please contact RMG Messtechnik without delay.

5.2 Disposing of packaging material

Dispose of device components and packaging material in an environmentally sound manner in accordance with the applicable waste management and national waste disposal regulations and standards of the region or country to which the device is delivered.

NOTE

Reusing the packaging

Where possible, retain the packaging, as it provides optimal protection if the device is ever transported again (e.g. if the place of installation is changed or if the device is sent off for repair).

5.3 Storing RFC 7

If it is necessary to store the Flow Computer RFC 7, observe the following:

- ▶ Avoid long storage periods.
- ▶ After storage, check the RFC 7 for damage and correct functioning.
- ▶ After a storage period exceeding one year, have the device checked by RMG Service. Send the device to RMG or arrange an appointment with the RMG Service organisation.
- ▶ Maintain the storage conditions listed below:
 - Packaged in clean, dry rooms
 - Temperature range -20 °C to 50 °C
 - Agitation (vibrations) must not occur during the storage period.
 - The device must not be stored under tension.

5.4 Transporting RFC 7

For transport, it is essential for the device to be given secure packaging that can absorb minor impacts and agitation.

- ▶ Nevertheless, inform the transport company that impacts and vibrations of any type must be avoided during transport.
- ▶ Ensure that the device is not exposed to any extreme fluctuations in temperature.

6 Installation



For installation, observe the safety information provided in section 3.3!

6.1 Mechanical installation

⚠ WARNING

Danger arising from incorrect mechanical installation

If the RFC 7 is not installed or mounted correctly, this may result in hazards to persons and property.

- ▶ Only specialists are permitted to perform the installation work.
- ▶ Only install the RFC 7 in accordance with the stipulations of this manual.
- ▶ For the installation, obtain permission from the system owner.

6.1.1 Place of installation and ambient conditions

The Flow Computer RFC 7 is intended for installation in a non-explosive atmosphere (safe area). It is connected via corresponding connection cables to gas meters, gas analysis devices, pressure sensors and/or temperature sensors that may be installed in an explosive atmosphere.

The following diagram illustrates the separation of the places of installation in a gas station into explosive zone and non-explosive zone.

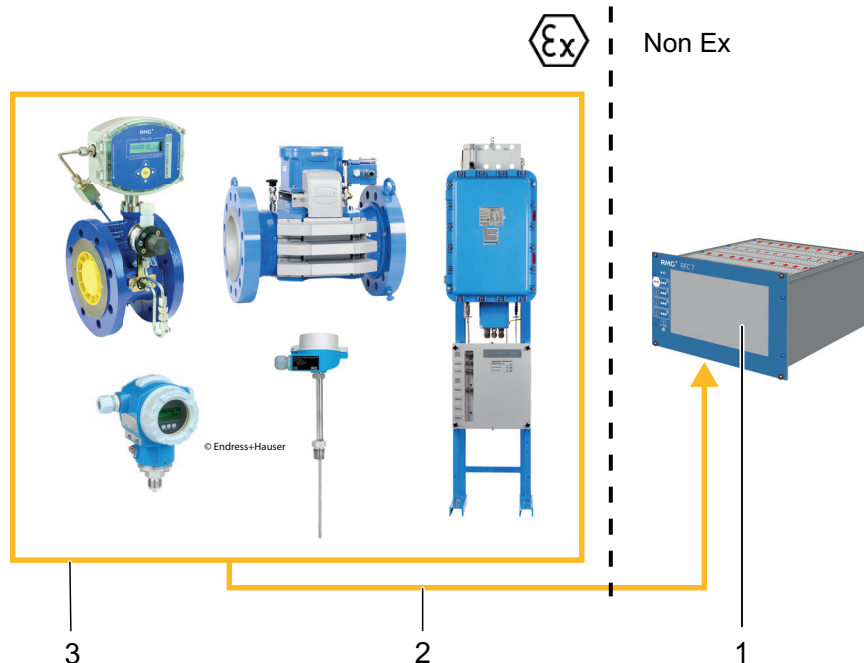

Fig. 16: Separation of the places of installation in a gas station

No.	Designation	No.	Designation
1	Flow Computer RFC 7	2	Connection cables
3	Gas meter, gas analysis device, pressure sensor and temperature sensor		

The following ambient conditions must be maintained at the place of installation:

Condition	Value
Humidity	0–95% relative humidity, non-condensing
Exposure to direct sunlight	Should be avoided where possible.
Ambient temperature	-20 to 55 °C
Temperature fluctuations	Large and rapid fluctuations in temperature should be avoided where possible.

Table 5: Ambient conditions for the RFC 7

6.1.2 Unit dimensions and weight

The Flow Computer RFC 7 is intended for installation in a rack inside a switch cabinet (non-explosive zone). Alternatively, it can be installed under other installation conditions. Depending on the device variant, it has the following dimensions:

- 19" housing (1–2 streams):
213.36 mm (42 HP) x 133.35 mm (3 RU) x 230 mm (W x H x D) (without connector on the back)
- 19" housing (3–4 streams):
426.72 mm (84 HP) x 133.35 mm (3 RU) x 230 mm (W x H x D) (without connector on the back)

The weight also varies, depending on the device, between approx. 1.75 kg (1 stream) and 2.25 kg (2 streams).

NOTE

Information on the Multi-Stream version

The Multi-Stream version listed will only be released at a later date. At present, no devices of this variant are available.

6.1.3 Installation

The RFC 7 in the Single-Stream version is supplied with four screws for installation in a rack.

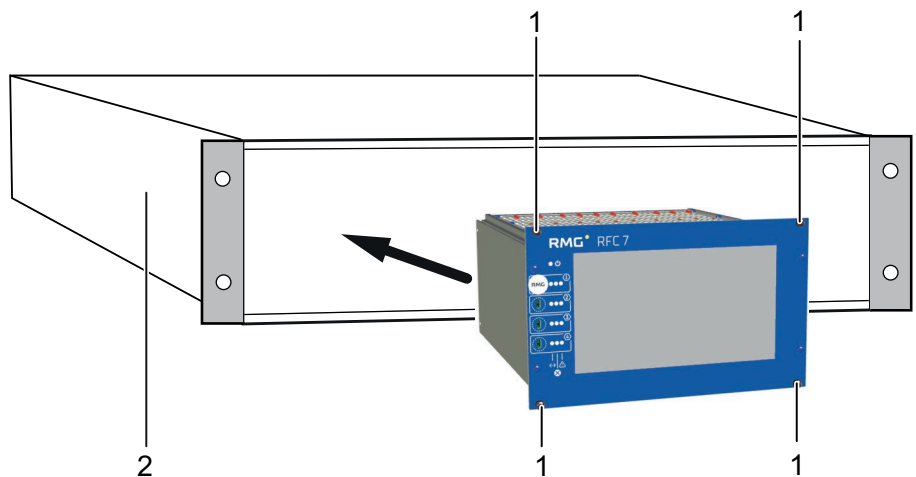

Fig. 17: Position of the screws on the front panel of the RFC 7 – Single-Stream

No.	Designation	No.	Designation
1	Screws, type M2.5x10	2	Rack

The RFC 7 in the Multi-Stream version is supplied with six screws for installation in a rack.

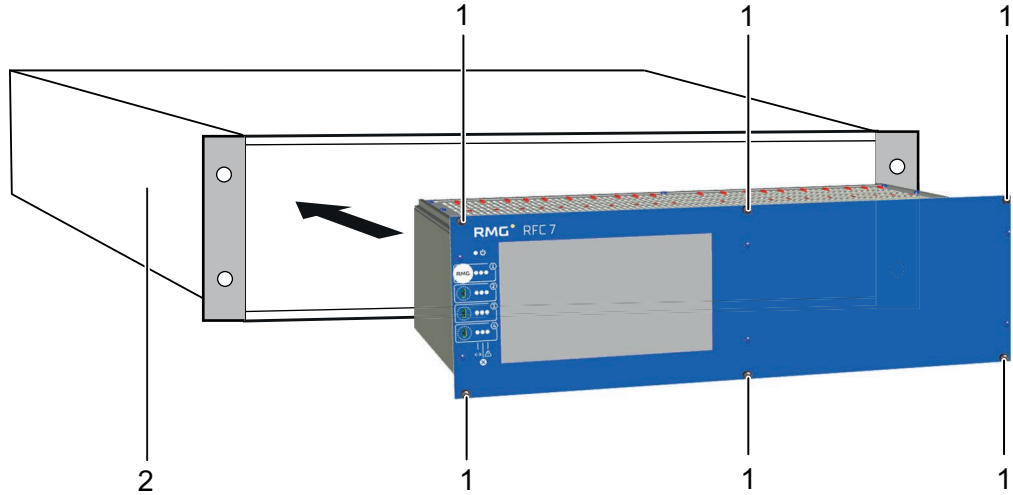

Fig. 18: Position of the screws on the front panel of the RFC 7 – Multi-Stream

No.	Designation	No.	Designation
1	Screws, type M2.5x10	2	Rack

Procedure for installation:

1. Insert the RFC 7 into the rack with the front panel facing forwards.
2. Place the RFC 7 in the required position and slightly tighten the screws (fig. 17 and fig. 18, no. 1) with a cross-head screwdriver.

6.2 Electrical installation

Before commencing work, ensure that all information and warnings from the above sections, in particular those from 3 ‘Safety information’ are observed and complied with. Ensure that the device is de-energised (power supply and signals) before any changes are made to the wiring. During work, it is essential to comply with the specifications given in the sections below.

⚠ DANGER

Danger of death arising from electrical voltage

Work that is not carried out correctly or on a de-energised device may result in extremely severe injury or death.

- ▶ Only have the electrical installation carried out by a specialist electrician, or a specialist electrician for specific activities, who can ensure that the installation is performed safely and correctly.
- ▶ Before any work is performed on the electrical installation, de-energise the device.
- ▶ Work on the device may only be performed after corresponding instruction with regard to the device has been provided.
- ▶ Ensure that the power data of the power supply connection corresponds to the specifications on the device's type label.
- ▶ Only use cables that correspond to the specifications and match the available cable glands.
- ▶ Equalise the potential of the housing by connecting an earthing cable to the housing.
- ▶ During installation, observe any national, regional and regulatory standards that may apply at the location of the device for electrical installation and explosion protection (e.g. EN, DIN, VDE).

6.2.1 Connections of the RFC 7

The RFC 7 has various electrical and signal connections for each stream, located on the device's back panel. The connections are described below, on the basis of the device Single-Stream device variant (cf. fig. 19).

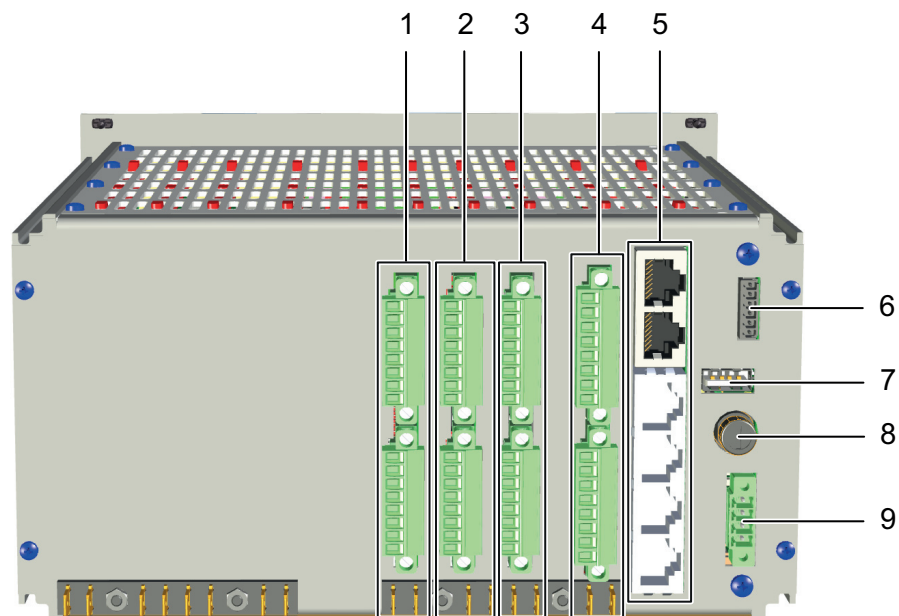

Fig. 19: Connections on the device's back panel (example: Single-Stream device variant)

No.	Designation	No.	Designation
1	IOC-Analog-Out connections with terminal strips X1 and X2	2	IOC-CPU connections with terminal strips X3 and X4

No.	Designation	No.	Designation
3	IOC-Digital-IO connections with terminal strips X5 and X6	4	IOC-EX-IO connections with terminal strips X7 and X8, intrinsically safe
5	CoM-Basis connections with X9A/B and X10A-D	6	Reserve
7	USB port	8	Fuse
9	Power supply 24 V DC		

6.2.2 Terminal assignments of the terminal strips

All connections / terminal strips on the device’s back panel are labelled as follows (cf. fig. 20).

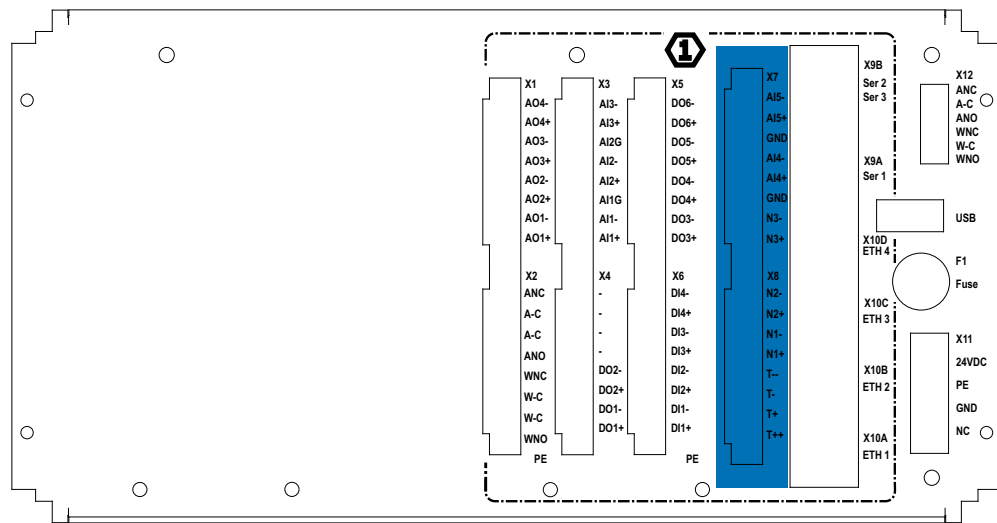

Fig. 20: Labelling of the connections on the device’s back panel (example: Single-Stream device variant)

The terminal connections of the individual cores of terminal strips X1 to X12 are listed below. Terminal numbers depicted with a light red background represent the coding for the corresponding connector (Phoenix).

- If it has not yet been done, please remove the strips from the connector (fig. 21, no. 1) with a wire cutter at the required position (see table 6 to table 9) to allow the connector to be inserted into the corresponding terminal strip.

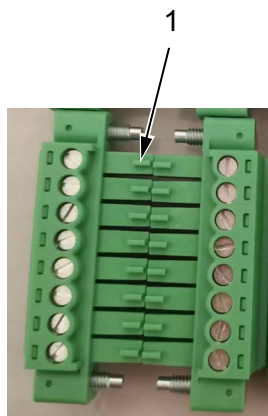

Fig. 21: Strip on connector (Phoenix)

IOC-Analog-Out, terminal strips X1 and X2

Terminal no.	Des. short	Designation long	Function
Terminal strip X1			
8	AO4-	Analogue output 4	The analogue outputs 1 to 4 can be used to output measured values. To enable this, each analogue output must be assigned a measurement value or a default value in menu 5. Outputs in the UI.
7	AO4+		
6	AO3-	Analogue output 3	
5	AO3+		
4	AO2-	Analogue output 2	
3	AO2+		
2	AO1-	Analogue output 1	
1	AO1+		
Terminal strip X2			
8	ANC	Alarm output NC	Contact closed in event of alarm.
7	A-C		
6	A-C	Alarm output NO	Contact open in event of alarm. (de-energise to trip)
5	ANO		
4	WNC	Warning output NC	Contact closed in event of a warning.
3	W-C		
2	W-C	Warning output NO	Contact open in event of a warning. (de-energise to trip)
1	WNO		

Table 6: Terminal connections, IOC-Analog-Out

IOC-CPU, terminal strips X3 and X4 (non-Ex)

Terminal no.	Des. short	Designation long	Function
Terminal strip X3			
8	AI3-	Analogue input 3	Analogue input 3 can be used to capture analogue measurement signals (4–20 mA). To enable this, the input in menu 6. Inputs must be parameterised accordingly.
7	AI3+		
6	AI2G	Analogue input 2 (with HART interface)	Analogue input 2 can be used to capture both analogue measurement signals (4–20 mA) and digital signals. (Use for temperature measurement is recommended.)
5	AI2-		
4	AI2+		
3	AI1G	Analogue input 1 (with HART interface)	Analogue input 1 can be used to capture both analogue measurement signals (4–20 mA) and digital signals. (Use for pressure measurement is recommended.)
2	AI1-		
1	AI1+		
Terminal strip X4			
8	T1--	4-wire PT100 (without line break monitoring)	Connecting a PT100 with 4-wire technology for precise temperature measurement.
7	T1-		
6	T1+		
5	T1++		
4	DO2-	Digital output 2	
3	DO2+		
2	DO1-	Digital output 1	
1	DO1+		

Table 7: Terminal connections, IOC-CPU

IOC-Digital-IO, terminal strips X5 and X6

Terminal no.	Des. short	Designation long	Function
Terminal strip X5			
8	DO6-	Digital output 6 (pulse output)	The digital outputs 3 to 6 can be used to output various calculation values. To enable this, the outputs in menu 5. Outputs must be parameterised accordingly.
7	DO6+		
6	DO5-	Digital output 5 (pulse output)	
5	DO5+		
4	DO4-	Digital output 4 (pulse output)	
3	DO4+		
2	DO3-	Digital output 3 (pulse output)	
1	DO3+		
Terminal strip X6			
8	DI4-	Digital input 4	Digital input 4 can be used for monitoring, for example, door switches.
7	DI4+		
6	DI3-	Digital input 3	Digital input 3 can be used to switch the route.
5	DI3+		
4	DI2-	Digital/pulse input 2 (PI4)	The digital inputs 1 and 2 can be used to process frequencies/pulses. To enable this, the inputs in menu 6. Inputs must be parameterised accordingly.
3	DI2+		
2	DI1-	Digital/pulse input 1 (PI3)	
1	DI1+		

Table 8: Terminal connections IOC-Digital-IO

IOC-Ex-IO, terminal strips X7 and X8 (intrinsically safe Ex I input card)

Terminal no.	Des. short	Designation long	Function
Terminal strip X7			
8	AI5-	Analogue output 5 (with HART interface)	Analogue input 5 can be used to capture both analogue measurement signals (4–20 mA) and digital signals. (Use for temperature measurement is recommended.)
7	AI5+		
6	GND		
5	AI4-	Analogue output 4 (with HART interface)	Analogue input 4 can be used to capture both analogue measurement signals (4–20 mA) and digital signals. (Use for pressure measurement is recommended.)
4	AI4+		
3	GND		
2	N3-	Encoder	Digital encoder input
1	N3+		

Table 9: Terminal connections, IOC-Ex-IO

Terminal no.	Des. short	Designation long	Function
Terminal strip X8			
8	N2-	Pulse input 2	Digital pulse input for reed or Namur
7	N2+	Reed/Namur (PI2)	
6	N1-	Pulse input 1	Digital pulse input for reed or Namur
5	N1+	Reed/Namur (PI1)	
4	T--	4-wire PT100-Ex (without line break monitoring)	Connecting a PT100 with 4-wire technology for precise temperature measurement.
3	T-		
2	T+		
1	T++		

Table 9: Terminal connections, IOC-Ex-IO

CoM-Basis, terminal strips X9 A/B and X10 A-D

Terminal no.	Des. short	Designation long	Function/protocols
Terminal X9B (type RJ45)			
	Ser2	Serial interface 2 RS485	ModbusClient for GBH / ModbusClient for USZ / ModbusServer RTU / ModbusServer ASCII
	(Ser3 optional)	(Serial interface 3 RS485 optionally via adapter)	ModbusClient for GBH / ModbusClient for USZ / ModbusServer RTU / ModbusServer ASCII
Terminal X9A (type RJ45)			
	Ser1	Serial interface 1 RS485	ModbusClient / ModbusClient for GBH / ModbusClient for USZ / ModbusServer RTU / ModbusServer ASCII / DSfG-A
Terminal X10D (type RJ45)			
	ETH 4	Ethernet 4	To connect a PC or local network, RJ45 port for Ethernet (DHCP client or fixed IP address) Protocols: - Modbus TCP/IP - http - SNTp
Terminal X10C (type RJ45)			
	ETH 3	Ethernet 3	See Ethernet 4
Terminal X10B (type RJ45)			
	ETH 2	Ethernet 2	See Ethernet 4

Table 10: Terminal connections, CoM-Basis

Terminal no.	Des. short	Designation long	Function/protocols
Terminal X10A (type RJ45)			
	ETH 1	Ethernet 1	See Ethernet 4

Table 10: Terminal connections, CoM-Basis

Power pack, terminal strips X11 and X12, USB port, fuse

Terminal no.	Des. short	Designation long	Function
Terminal strip X12			
6	ANC	Reserve	
5	A-C		
4	ANO		
3	WNC	Reserve	
2	W-C		
1	WNO		
USB			
	USB	Universal Serial Bus	Optional
F1			
	Fuse	Fuse	To protect the RFC 7 from excess current
Terminal strip X11			
1	24VDC	Power supply +24 V	Power supply of the RFC 7
2	PE	Equipotential bonding	
3	GND	0 V	
4	NC	Not assigned	

Table 11: Terminal connections, power pack

6.2.3 Pin configuration of the serial interfaces Ser1 – Ser3 (RS-485)

Adapter RJ45 plug to DE-9 connector (D-Sub, 9-pin)

The adapter can be used on the following terminals:

- X9A, Ser1
- X9B, Ser2

The following pin assignment applies (see also fig. 22):

RJ45, pin number	signal	DE-9 connector, pin number
1	485_A	3
2	485_B	8
4	VDD	1
5	Gnd	2, 5, 6, 7

Table 12: Pin assignment for adapter RJ45 plug – DE-9 connector (D-Sub, 9-pin)

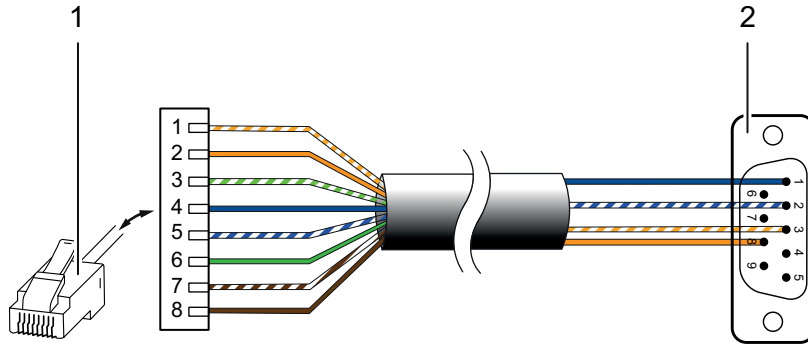

Fig. 22: Pin assignment for adapter RJ45 plug – DE-9 connector (D-Sub, 9-pin)

No.	Designation	No.	Designation
1	RJ45 plug	2	DE-9 connector

Y-Adapter RJ45 plug to 2 x DE-9 connector (D-Sub, 9-pin)

The Y-adapter is an accessory and is used to expand the system to three serial interfaces.

It can be used on the following terminal:

- X9B, Ser2

The following pin assignment applies (see also fig. 23):

RJ45, pin number	signal	DE-9 connector, pin number
1	485_A	3
2	485_B	8
4	VDD	1
5	Gnd	2, 5, 6, 7
3	485_A	3
6	485_B	8
7	VDD	1
8	Gnd	2, 5, 6, 7

Table 13: Pin assignment for Y-Adapter RJ45 plug – DE-9 connector (D-Sub, 9-pin)

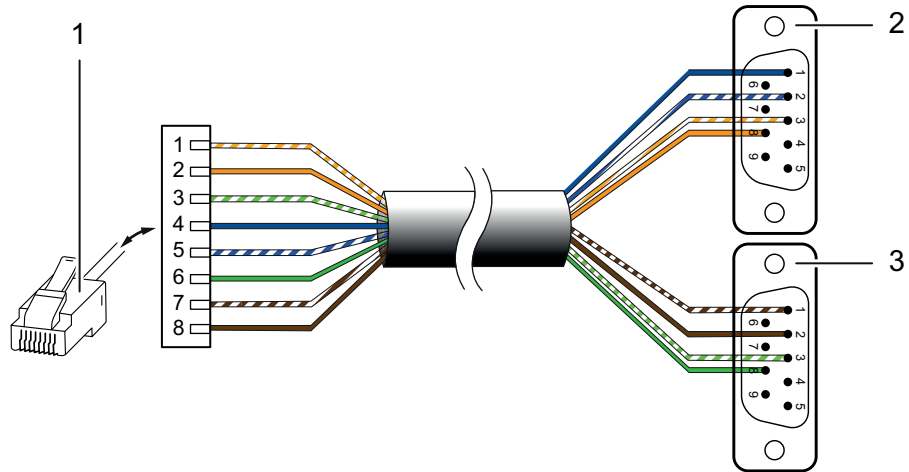

Fig. 23: Pin assignment for Y-Adapter RJ45 plug – DE-9 connector (D-Sub, 9-pin)

No.	Designation	No.	Designation
1	RJ45 plug	2	DE-9 connector for Ser2
3	DE-9 connector for Ser3		

6.2.4 Power supply and fuse protection

The RFC 7 must be supplied with a supply voltage of 24 V (DC). The terminal strip X11 is intended to be used for this.

To provide protection from excess current, the device has a fuse (F1) that is triggered at 4 amps.

The voltage available at the place of use must be checked for correctness and usability. The following criteria must be observed:

- Voltage range: 24 V DC ($\pm 10\%$)
- The safety device with the above-mentioned properties must be functional.

6.2.5 Connecting the temperature measurement

To measure the current operating temperature of the measured gas, the following forms of temperature measurement may be used:

- PT100 sensor: A PT100 is a platinum resistance thermometer that changes its resistance in accordance with the temperature. At 0 °C it has a resistance of 100 ohms. If a 4-wire circuit is used for connection, this circuit will fully compensate for the line resistance and provide maximum precision. A PT100 is used **without** line break resistors.
- Temperature transmitter: A temperature transmitter converts a signal from a temperature sensor (such as a PT100) into a standardised analogue or digital output signal that can easily be processed by the Flow Computer RFC 7 (4–20 mA and/or HART).

Both the PT100 and the temperature transmitter are typically located in a potentially explosive atmosphere and therefore need to be operated with the correct protection class when connected to the Flow Computer.

Fundamentally, a temperature transmitter could be connected to any of the analogue inputs of the RFC 7. However, when selecting the connection, the protection class of the temperature transmitter must be taken into account.

Transmitters of protection class Ex i can be used exclusively via the IOC-EX-IO card (terminal strips 7 and 8 on the device's back panel).

If transmitters with HART protocol are used, it must be borne in mind that not all analogue inputs support the HART protocol (cf. section 6.2.2 "Terminal assignments of the terminal strips"). For HART transmitters for applications involving official calibration (MID), a Welmec type certificate is also necessary.

NOTE

Observe temperature sensor/transmitter operating instructions!

As a wide variety of temperature sensors/transmitters may be used in combination with the Flow Computer RFC 7, only the wiring at the Flow Computer is discussed below.

- ▶ For detailed information on connecting the specific temperature sensor/transmitter, please refer to the operating instructions of the corresponding manufacturer.

Connecting a PT100 with 4-wire technology with protection class Ex i to terminal strip X8, terminal no. 1–4

A PT100 is to be connected to the above-mentioned terminals in accordance with fig. 24.

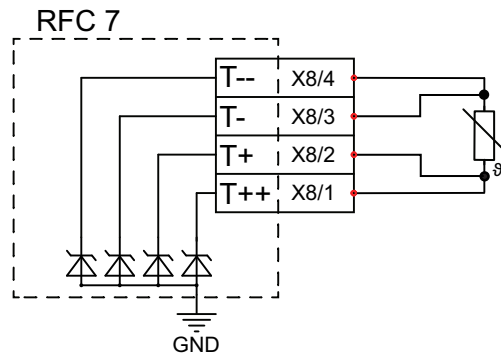

Fig. 24: El. connection PT100, protection class Ex i

In order to use the PT100, it must be connected as shown and parameterised accordingly on the menu page **6.121 PT100 Ex** (cf. section 8.8.3 "PT100 – defining parameters").

Connecting a PT100 with 4-wire technology with protection class Ex d to terminal strip X4, terminal no. 5–8

A PT100 is to be connected to the above-mentioned terminals in accordance with fig. 25.

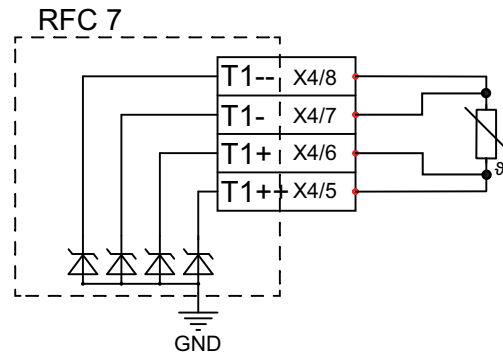

Fig. 25: El. connection PT100, protection class Ex d

In order to use the PT100, it must be connected as shown and parameterised accordingly on the menu page **6.120 PT100 Non-Ex** (cf. section 8.8.3 "PT100 – defining parameters").

Connecting an analogue or digital temperature transmitter with protection class Ex i to analogue input 5, terminal strip X7, terminal no. 6–8

If a temperature transmitter is connected to analogue input 5, it is important to note whether the transmitter has its own power supply (active sensor) or whether it needs to be supplied with power via the Flow Computer (passive sensor). The connection must then be implemented accordingly – cf. fig. 26 and fig. 27.

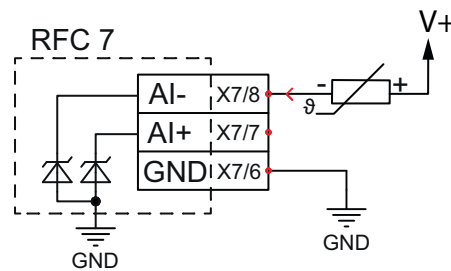

Fig. 26: Connecting an active temperature transmitter

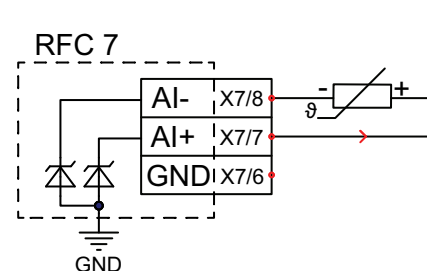

Fig. 27: Connecting a passive temperature transmitter

In order to use analogue input 5 for a digital temperature transmitter, the transmitter must be connected as shown and parameterised accordingly on the menu page **6.115 Analogue input 5 with HART** (cf. section 8.8.2 "Analogue inputs – defining parameters").

Connecting an analogue or digital temperature transmitter with protection class Ex d to analogue input 2, terminal strip X3, terminal no. 4–6

If a temperature transmitter is connected to analogue input 2, it is important to note whether the transmitter has its own power supply (active sensor) or whether it needs to be supplied with power via the Flow Computer (passive sensor). The connection must then be implemented accordingly – cf. fig. 28 and fig. 29.

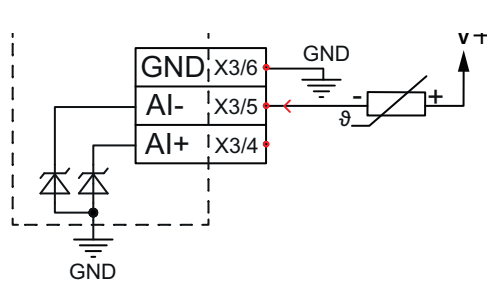

Fig. 28: Connecting an active temperature transmitter

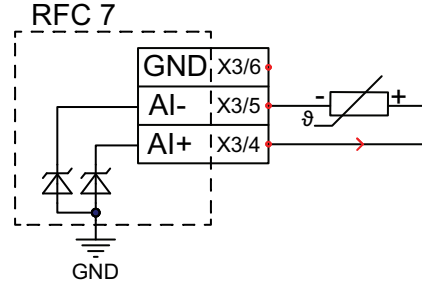

Fig. 29: Connecting a passive temperature transmitter

In order to use analogue input 2 for a digital temperature transmitter, the transmitter must be connected as shown and parameterised accordingly on the menu page **6.101 Analogue input 1 with HART** (cf. section 8.8.2 "Analogue inputs – defining parameters").

6.2.6 Connecting pressure measurement

To measure the current operating pressure of the measured gas, a pressure transmitter is used. The pressure transmitter’s measuring range and level precision are determined by the specific operating conditions.

The pressure transmitter is typically located in a potentially explosive atmosphere and therefore needs to be operated with the correct protection class when connected to the Flow Computer.

Fundamentally, a pressure transmitter could be connected to any of the analogue inputs of the RFC 7. However, when selecting the connection, the protection class of the pressure transmitter must be taken into account.

Transmitters of protection class **Ex i** can be used exclusively via the **IOC-EX-IO card** (terminal strips X7 and 8 on the device’s back panel).

If transmitters with HART protocol are used, it must be borne in mind that not all analogue inputs support the HART protocol (cf. section 6.2.2 "Terminal assignments of the terminal strips"). For HART transmitters for applications involving official calibration (MID), a Welmec type certificate is also necessary.

NOTE

Observe the pressure transmitter operating instructions!

As a wide variety of pressure transmitters may be used in combination with the Flow Computer RFC 7, only the wiring at the Flow Computer is discussed below.

- ▶ For detailed information on connecting the specific pressure transmitter, please refer to the operating instructions of the corresponding manufacturer.

Connecting an analogue or digital pressure transmitter to analogue input 4, terminal strip X7, terminal no. 3–5

If a pressure transmitter is connected to analogue input 4, it is important to note whether the transmitter has its own power supply (active sensor) or whether it needs to be supplied with power via the Flow Computer (passive sensor). The connection must then be implemented accordingly – cf. fig. 30 and fig. 31.

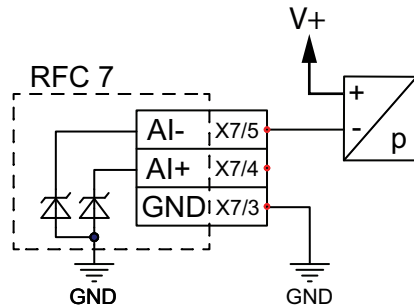

Fig. 30: Connecting an active pressure transmitter

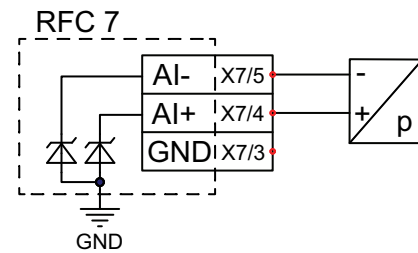

Fig. 31: Connecting a passive pressure transmitter

In order to use analogue input 4 for a digital pressure transmitter, the transmitter must be connected as shown and parameterised accordingly on the menu page **6.114 Analogue input 4 with HART** (cf. section 8.8.2 "Analogue inputs – defining parameters").

Connecting an analogue or digital pressure transmitter to analogue input 1, terminal strip X3, terminal no. 1–3

If a pressure transmitter is connected to analogue input 1, it is important to note whether the transmitter has its own power supply (active sensor) or whether it needs to be supplied with power via the Flow Computer (passive sensor). The connection must then be implemented accordingly – cf. fig. 32 and fig. 33.

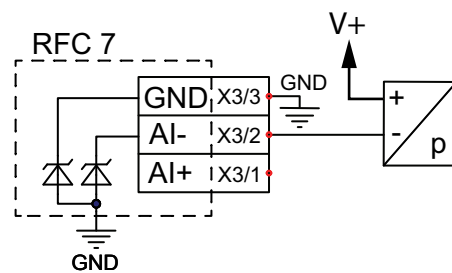

Fig. 32: Connecting an active pressure transmitter

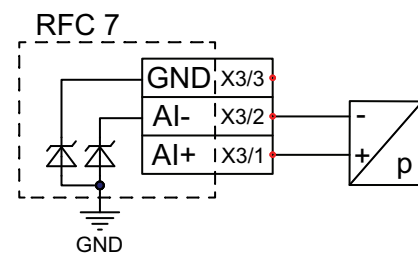

Fig. 33: Connecting a passive pressure transmitter

In order to use analogue input 1 for a digital pressure transmitter, the transmitter must be connected as shown and parameterised accordingly on the menu page **6.100 Analogue input 1 with HART** (cf. section 8.8.2 "Analogue inputs – defining parameters").

6.2.7 Connecting mechanical gas meters

Mechanical gas meters that may be used include turbine meters, for example. The operating principle of a turbine gas meter involves using a turbine wheel to measure the gas speed. The rotational speed of the turbine wheel is (approximately) proportional to the mean gas speed and therefore to the flow within the measuring range (Q_{min} – Q_{max}). The number of rotations can thus be used to determine the flow rate of the gas.

To measure the rotational speed, various signal transmitters/pulse generators are available, which transmit low-frequency (LF) or high-frequency (HF) pulses to the Flow Computer. The following diagram gives an example overview of how they could be arranged in a turbine gas meter (cf. fig. 34).

In principle, the processing of the low-frequency (reed) or high-frequency (Namur, open collector) pulses in the RFC 7 is independent from the measurement principle used by the connected gas meter; even rotary piston gas meters and other flow meters with frequency output may be connected to the Flow Computer.

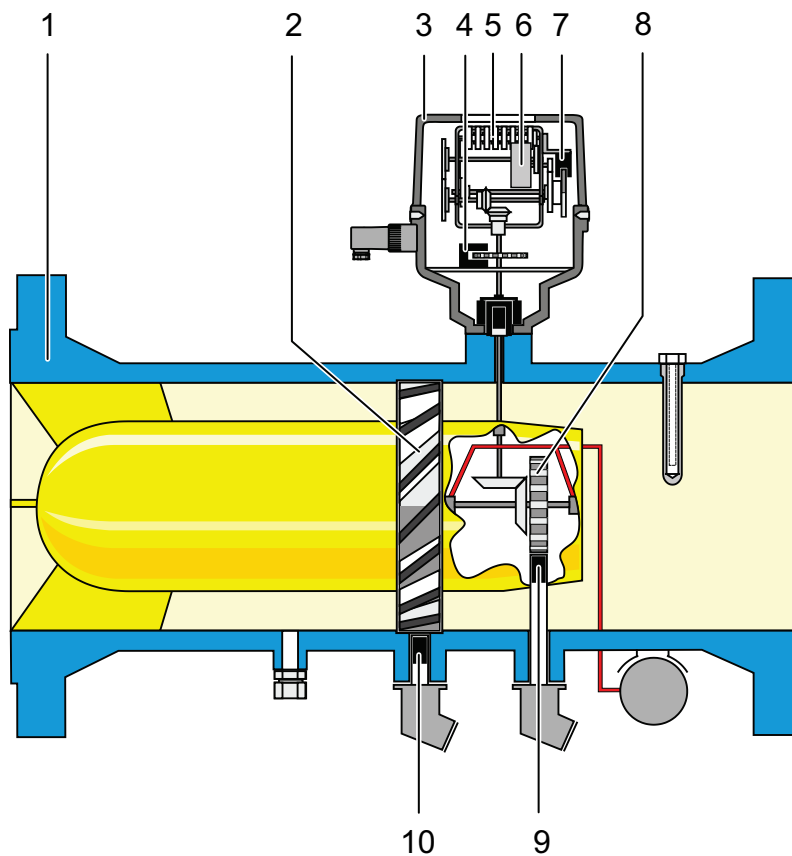

Fig. 34: Section drawing of a turbine gas meter (example)

No.	Designation	No.	Designation
1	Housing, turbine gas meter	2	Turbine wheel
3	Counter head	4	Pulse generator 3 (adjustment gear)
5	Mechanical counter	6	Encoder
7	Pulse generator 4 (mechanical counter)	8	Reference wheel
9	Pulse generator 2 (reference wheel)	10	Pulse generator 1 (turbine wheel)

The choice as to which pulse generator should be connected to the Flow Computer should be based on the individual requirements.

NOTE

Observe the mechanical gas meter operating instructions!

As a wide variety of mechanical gas meters may be used in combination with the Flow Computer RFC 7, only the wiring at the Flow Computer is discussed below.

- ▶ For detailed information on connecting the specific mechanical gas meter, please refer to the operating instructions of the corresponding manufacturer.

The mechanical gas meter is typically installed in a potentially explosive atmosphere, so it therefore needs to be securely separated when connected to the Flow Computer.

Accordingly, the Flow Computer RFC 7 provides the following connections at the IOC-EX-IO card – cf. the illustrations provided below:

- Pulse input reed/Namur 1, **terminal strip X8, terminal no. 5 and 6**
- Pulse input reed/Namur 2, **terminal strip X8, terminal no. 7 and 8**
- Encoder input, **terminal strip X7, terminal no. 1 and 2**

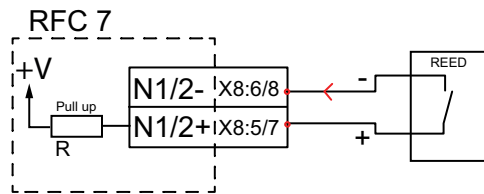

Fig. 35: Connection of mech. counter via reed

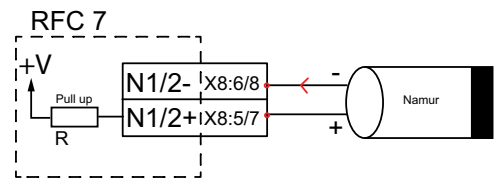

Fig. 36: Connection of mech. counter via Namur

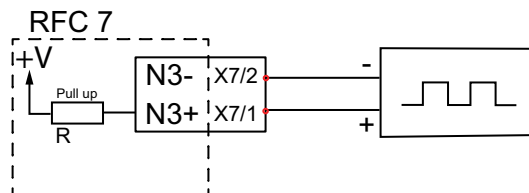

Fig. 37: Connection of encoder

Pulse inputs 1 and 2 are used to capture the rotational speed / frequency regardless of the turbine wheel's direction of travel, which serves as the basis for determining the operational flow rate. The result is written to the counters. In addition, pulse inputs 1 and 2 are used for synchronisation monitoring when two different pulse generators are connected.

The encoder input is used to transmit the counter reading of the mechanical counter to the Flow Computer digitally. It also captures whether the turbine wheel, i.e. the gas meter, is running forwards or backwards. In addition, the encoder provides the original counter reading in the event of a fault. However, during a fault, the fault counters run in place of the volume counters.

In order to use the pulse inputs and the encoder input, they must be connected as shown above and parameterised accordingly on the relevant menu pages (cf. sections 8.8.4 "Frequency and pulse input – defining parameters" and 8.8.5 "Encoder settings"):

- 6.200 Frequency and pulse input 1
- 6.201 Frequency and pulse input 2
- 6.300 Encoder settings

6.2.8 Connecting an ultrasonic gas meter

An ultrasonic gas meter determines the flow rate on the basis of the physical principle that an ultrasonic pulse is able to spread more quickly in a gas’s direction of flow than in the opposite direction. A travel-time measurement of the ultrasonic pulses between two ultrasonic transducers arranged opposite one another can be used to determine the flow speed and thus the flow rate. To achieve greater accuracy, several pairs of ultrasonic transducers are typically used, arranged opposite one another at various levels of the gas meter cross-section, forming so-called measurement paths (cf. fig. 38).

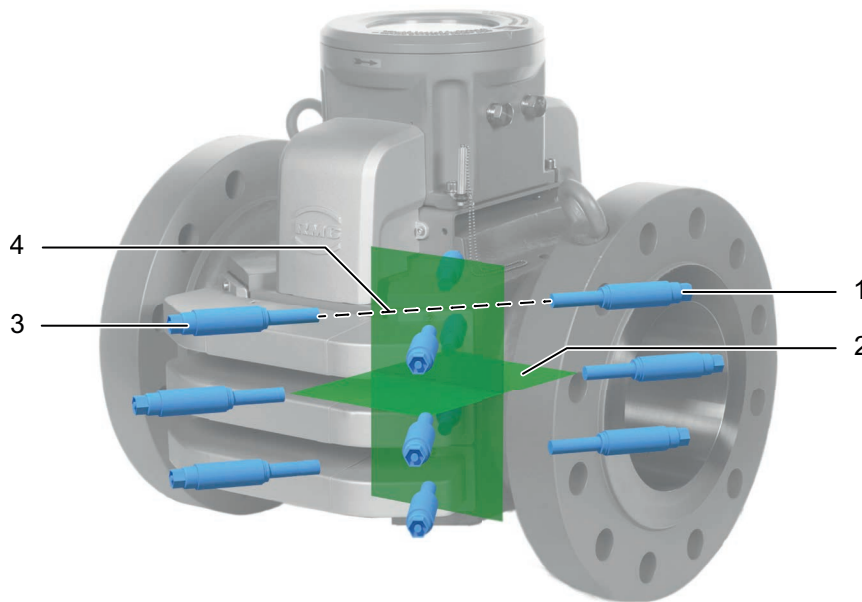

Fig. 38: Principle diagram of the arrangement of ultrasonic transducers

No.	Designation	No.	Designation
1	Ultrasonic transducer	2	Measurement level
3	Ultrasonic transducer	4	Measurement path

To connect an ultrasonic gas meter, the Flow Computer RFC 7 provides the following connections at the CoM-Basis in the device’s back panel:

- Serial interface RS485 (Ser 1), **terminal strip X9A, type RJ45**
- Serial interface RS485 (Ser 2), **terminal strip X9B, type RJ45**
- (Optionally via adapter: serial interface RS485 (Ser 3), **terminal strip X9B, type RJ45**)
- Ethernet interfaces 1–4 (Eth1–Eth4), **terminal strip X10A-D, type RJ45**

To realise the connection, proceed as follows:

- ▶ Connect a patch cable with an RJ45 plug from the ultrasonic gas meter to the desired serial or Ethernet interface. Please note that the serial and Ethernet interfaces do not have an intrinsically safe design.

The following pin assignment applies:

RJ45, pin number	wire colour	signal
1	orange-white	485_A
2	orange	485_B
4	blue	VDD
5	blue-white	Gnd

Table 14: Pin assignment of RJ45 plug for serial interface

In order to use the serial interfaces, they must be parameterised accordingly on the relevant menu page **9.7 Serial interfaces**.

In order to use the Ethernet ports, they must be parameterised on the relevant menu pages **9.11–9.14 Ethernet 1–4**.

In total, two interfaces can be used as USM client.

NOTE

Observe the operating instructions of the ultrasonic gas meter!

As a wide variety of ultrasonic gas meters may be used in combination with the Flow Computer RFC 7, only the connection at the Flow Computer is discussed here.

- ▶ For detailed information on connecting the specific ultrasonic gas meter, please refer to the operating instructions of the corresponding manufacturer.

6.2.9 Connecting gas quality measurement device

A gas quality measurement device serves to analyse the composition and quality of a gas, such as natural gas, biogas and other gas mixtures. To do this, gas chromatographs are used to identify and quantify the various components of the gas. A controller uses the measured percentages to calculate key characteristics such as the calorific value, standard density and Wobbe index.

To enable the various types of data to be retrieved by the gas quality measurement device's controller, the Flow Computer RFC 7 provides the following connections at the CoM-Basis in the device's back panel:

- Serial interface RS485 (Ser 1), **terminal strip X9A, type RJ45**
- Serial interface RS485 (Ser 2), **terminal strip X9B, type RJ45**
- (Optionally via adapter: serial interface RS485 (Ser 3), **terminal strip X9B, type RJ45**)
- Ethernet interfaces 1–4 (Eth1–Eth4), **terminal strip X10A-D, type RJ45**

To realise the connection, proceed as follows:

- ▶ Connect a patch cable of the gas quality measurement device's controller to the desired serial interface or Ethernet port.

In order to use the serial interfaces, they must be parameterised accordingly on the relevant menu page **9.7 Serial interfaces**.

In order to use the pulse inputs and the encoder input, they must be connected as shown above and parameterised as accordingly on the relevant menu pages **9.11–9.14 Ethernet 1–4**:

The serial and Ethernet interfaces do not have an intrinsically safe design.

In total, two interfaces can be used as gas quality client.

NOTE

Observe the operating instructions of the gas quality measurement device's controller!

As a wide variety of controllers may be used in combination with the Flow Computer RFC 7, only the connection at the Flow Computer is discussed here.

- ▶ For detailed information on connecting the specific controller, please refer to the operating instructions of the corresponding manufacturer.

7 User Interface Operation

The Flow Computer RFC 7 can be operated either from the touchscreen or from a PC.

Both options essentially provide the same functionality. There are some differences in how the menu pages are structured and how you navigate between the menus, however. Some functions such as the functional test can only be carried out from a PC!



The differences between the two forms of operation are described in detail below in sections 7.1 "Operation from the touchscreen" and 7.2 "Operation from PC". Functions and symbols that are identical for the two forms of operation are described in sections 7.3 "Controls in the header" and 7.4 "Controls in the display field".

7.1 Operation from the touchscreen

Operating the RFC 7 from the touchscreen enables simple operation via a graphic user interface and straightforward menus. After the device has started up, the start menu is displayed on the touchscreen automatically.

NOTE

Damage to the touchscreen

Handling the touchscreen incorrectly could cause it to become damaged.

- ▶ Operate the touchscreen with your fingers or use a suitable plastic stylus.
- ▶ Never use a hard or sharp-edged object such as a screwdriver or pencil, as this could scratch or fracture the touchscreen film.

NOTE

Display deactivation during inactivity

If the touchscreen is inactive for a certain period, the display may switch off automatically. The time interval before deactivation can be configured individually.

- ▶ Navigate to menu 9.410 Screen/Screensaver (see section 7.1.2 "Navigating between the menus"). Set the desired time interval in coordinate 9.410.20 Screensaver Timeout.
- ▶ If the display has switched off, touch the touchscreen to switch it back on. The display will automatically return to the menu "1.40 Counter".

7.1.1 Structure of the menu pages (touchscreen)

All the menu pages have an identical structure (cf. fig. 39).

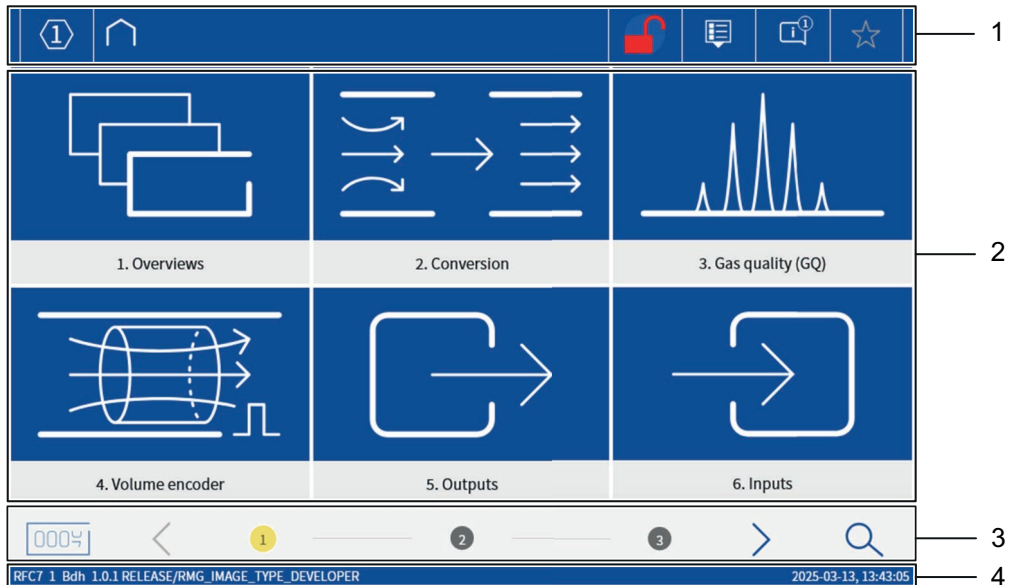

Fig. 39: Start menu – touchscreen

No.	Designation	No.	Designation
1	Header	2	Display field
3	Footer	4	Info line

Header (no. 1)

The header is available on every menu page and always has the same structure. It is used to jump back to a higher menu level (cf. section 7.2.2 "Navigating between the menus") and has various buttons; the functions of these buttons are described in detail in section 7.3 "Controls in the header".

Display field (no. 2)

The displayed content and the functions that can be executed in the display field change depending on which menu is currently selected.

Footer (no. 3)

The footer is used to navigate between the individual menu pages within a level. In addition, corresponding button can be used to switch to menu 1.40 Counters at any time (cf. section 7.2.2 "Navigating between the menus").

Info line (no. 4)

The info line displays the app version, the device designation and the date and time.

7.1.2 Navigating between the menus

The operation menus are arranged in three levels (cf. fig. 40).

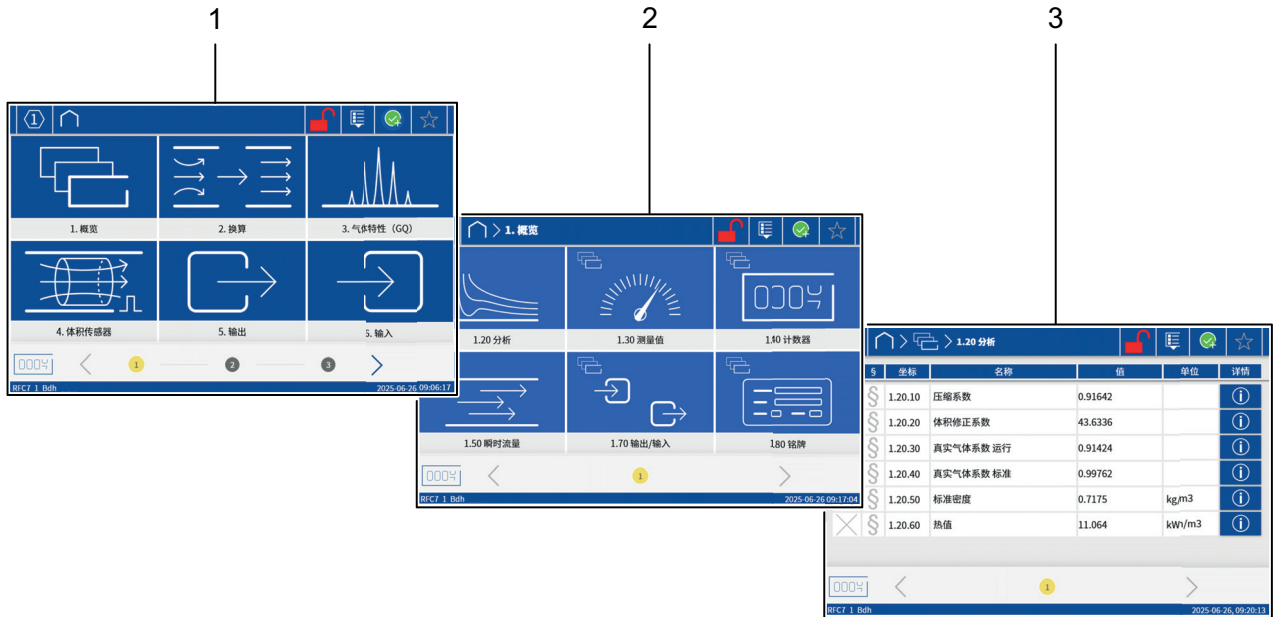

Fig. 40: Menu levels

No.	Designation	No.	Designation
1	Section level (top level)	2	Subsection level (middle level)
3	Parameter level (bottom level)		

Section level (no. 1)

This level provides an overview of the available topic areas, referred to as sections. It may contain multiple menu pages. The first page of the section level is also the **start menu**, which is displayed when the RFC 7 starts up.

Each section is designed as a **button** with an easy-to-understand icon (cf. fig. 41, example). Pressing the button opens the corresponding subsection level.

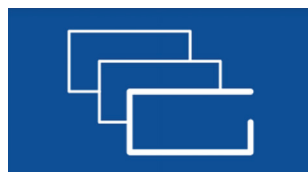

Fig. 41: Section button (1. Overviews, example)

Subsection level (no. 2)

This level provides an overview of the available subsections. This level may also contain multiple menu pages.

Each subsection is designed as a **button** with both the icon for the higher section level (cf. fig. 42, no. 1) and an easy-to-understand icon representing its topic area (cf. fig. 42, no. 2). Pressing the button opens the corresponding parameter level.

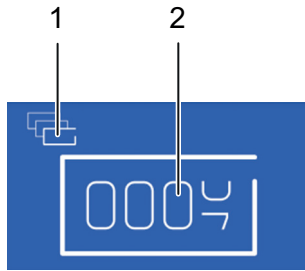

Fig. 42: Subsection button (1.40 Counters, example)

No.	Designation	No.	Designation
1	Section level icon	2	Subsection level icon

Parameter level (no. 3)

This level contains the required data for the individual parameters, arranged in lines in a table. This table may cover multiple menu pages.

Navigating between the menu levels and pages

You can navigate from the start menu (section level) to the parameter level as described above by clicking the corresponding buttons in the display field.

To navigate back to the next higher menu level, you can use the header and its buttons on any menu page (cf. fig. 43, nos. 1–3). You can navigate between the individual menu pages within a level by clicking the buttons in the footer (cf. fig. 43, nos. 5–8).



Fig. 43: Navigating between the menu levels and pages

No.	Designation	Function
1	Home button	<ul style="list-style-type: none"> Change back to the start menu in the section level
2	Section level button	<ul style="list-style-type: none"> Display the opened section level Change from the open parameter level back to the corresponding subsection level
3	Subsection level display	<ul style="list-style-type: none"> Display the opened subsection level
4	Search button	<ul style="list-style-type: none"> Open the input window for text or coordinate search
5	Right arrow button	<ul style="list-style-type: none"> Change to next menu page: <ul style="list-style-type: none"> Coloured grey: change is not possible Coloured blue: change is possible
6	Position indicator	<ul style="list-style-type: none"> Displays the position of the opened menu page within the current level. Pressing a free position field causes the indicator to jump to the selected position and the corresponding menu page opens.
7	Left arrow button	<ul style="list-style-type: none"> Change to prior menu page: <ul style="list-style-type: none"> Coloured grey: change is not possible Coloured blue: change is possible
8	Counters button	<ul style="list-style-type: none"> Change to menu 1.40 Counters

- ▶ You can press the various buttons in the display field and in the header and footer to navigate to any menu, open it and make changes there.

7.2 Operation from PC

For operation from the PC, the RFC 7 must be connected to a PC or an Ethernet network and the device's IP address must be entered in the internet browser (cf. section 8.3.1 "Establishing a network connection").

You can use the PC's keyboard and mouse to operate the device from the web view of the user interface.

7.2.1 Structure of the menu pages

All the menu pages of the web view have an identical structure (cf. fig. 44).

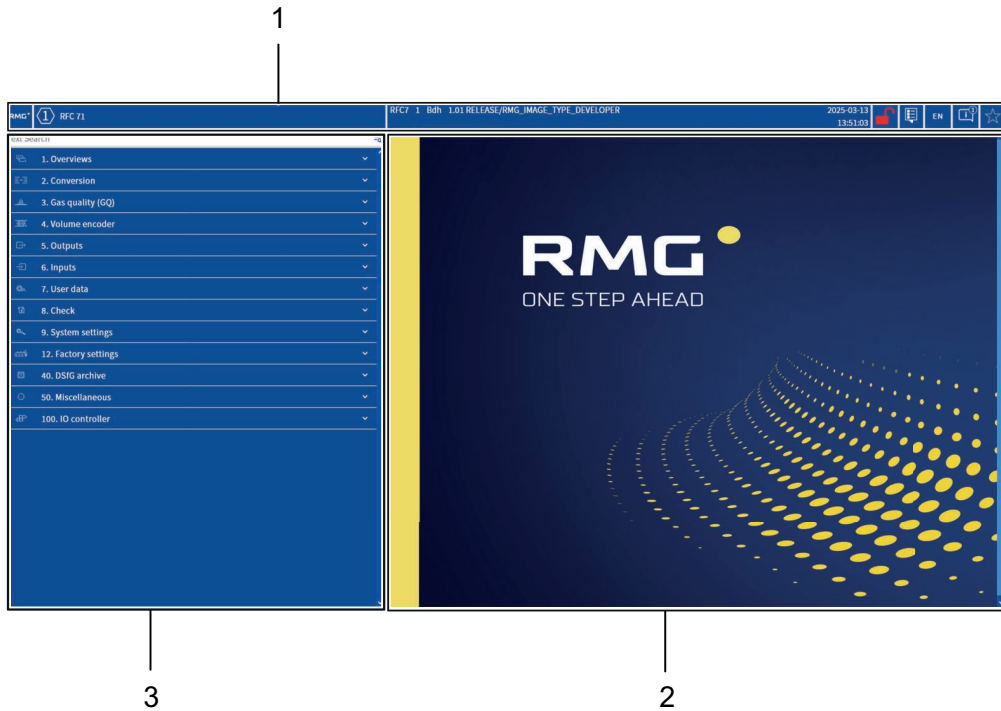

Fig. 44: Start menu – web view

No.	Designation	No.	Designation
1	Header	2	Display field
3	Navigation field		

Header (no. 1)

The header is available on every menu page and always has the same structure. It has various buttons. The functions of these buttons are described in detail in section 7.3 "Controls in the header".

Display field (no. 2)

The displayed content and the functions that can be executed in the display field change depending on which subsection is currently selected.

Navigation field (no. 3)

The navigation field is used to navigate between the individual sections/subsections and to select the menus of the parameter level that will then open in the display field.

7.2.2 Navigating between the menus

The operation menus, like those for touchscreen operation, are divided up into three levels (cf. fig. 45).

In the web view, however, all three levels can be displayed in the menu at the same time.

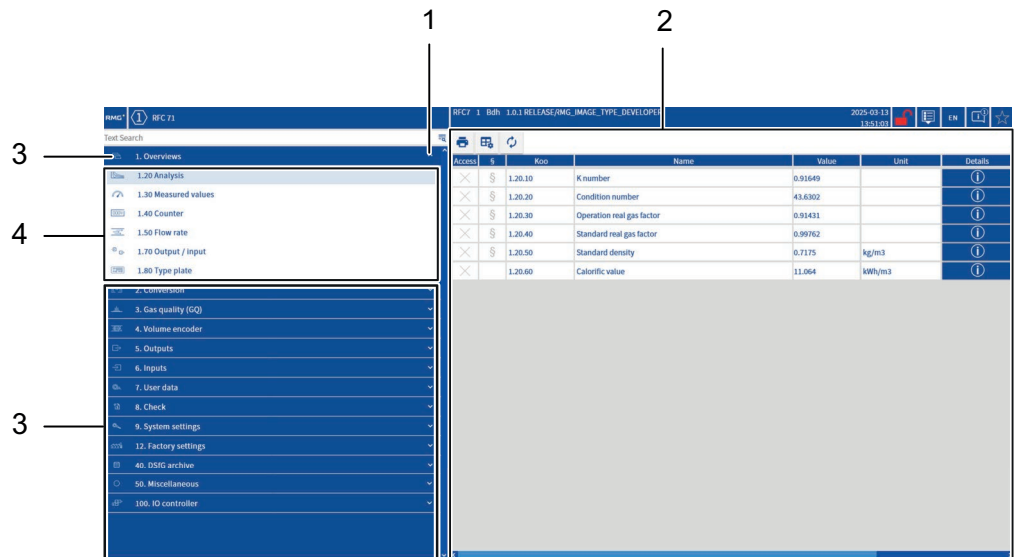

Fig. 45: Menu navigation – web view

No.	Designation	No.	Designation
1	Selection arrow	2	Parameter level (bottom level)
3	Section level (top level)	4	Subsection level (middle level)

To open a parameter level menu, proceed as follows:

- In the navigation field, selected the required section (no. 3) and click the corresponding selection arrow (no. 1) with the mouse to confirm (here: Section 1. Overviews).
 - The subsection level (no. 4) opens and all other sections move down.
- Use the mouse to select a subsection (here: 1.20 Analysis).
 - The subsection is displayed with a grey background and in the display field the corresponding parameter level menu opens (no. 2).

You can use the scrollbar on the side to navigate both in the navigation field in the section and subsection level and in the display field in the parameter level.

In this way, you can open, view and make changes in menus according to the access rights of the logged-in user.

7.3 Controls in the header

The controls are generally identical on the touchscreen and in the web view and will be described together.

They will be explained on the basis of the web view. If the controls are displayed differently on the touchscreen, the differences will be described.



Fig. 46: Header of the menu page – web view

No.	Designation	Function
1	Home button	<ul style="list-style-type: none"> Jump back to start page
2	Stream button	<ul style="list-style-type: none"> Display of the currently selected stream Change to another stream (only possible for Multi-Stream device variant)
3	Info field	<ul style="list-style-type: none"> Path describing which subsection is currently open Display of: <ul style="list-style-type: none"> - Date and time - App version
4	User log-in button	<ul style="list-style-type: none"> Display which user is logged in Display whether the calibration lock is open. Open user log-in window.
5	View button	<ul style="list-style-type: none"> Check the view at parameter level: <ul style="list-style-type: none"> - All parameters are displayed - Only the main parameters are displayed
6	Language button	<ul style="list-style-type: none"> Display of the currently selected language Change to language: <ul style="list-style-type: none"> - DE (German) - EN (English) - ZH (Chinese)
7	Messages button	<ul style="list-style-type: none"> Display the message with the highest priority Open message list.
8	Favourites button	<ul style="list-style-type: none"> Display whether the open menu is saved as a favourite. Open the favourite list



Fig. 47: Header of the menu pages – touchscreen

No.	Designation	Function
1	Stream button	<ul style="list-style-type: none"> ■ Display of the currently selected stream ■ Change to another stream (only possible for Multi-Stream device variant)
2	Home button	<ul style="list-style-type: none"> ■ Change back to the start menu in the section level
3	Section level button	<ul style="list-style-type: none"> ■ Display the opened section level ■ Change from the open parameter level back to the corresponding subsection level
4	Subsection level display	<ul style="list-style-type: none"> ■ Display the opened subsection level
5	User log-in button	<ul style="list-style-type: none"> ■ Display which user is logged in ■ Display whether the calibration lock is open. ■ Open user log-in window.
6	View button	<ul style="list-style-type: none"> ■ Check the view at parameter level: <ul style="list-style-type: none"> - All parameters are displayed - Only the main parameters are displayed
7	Messages button	<ul style="list-style-type: none"> ■ Display the message with the highest priority ■ Open message list (cf. section 7.3.3).
8	Favourites button	<ul style="list-style-type: none"> ■ Display whether the open menu is saved as a favourite. ■ Open the favourite list

7.3.1 User log-in

The **User log-in** button has three functions:

1. Display the logged-in user/administrator

	No user is logged in
	User 1 is logged in (the number changes depending on which user is logged in)
	Administrator 1 is logged in (the number changes depending on which admin is logged in)

2. Display whether the calibration lock is open

	Calibration lock open
	Calibration lock open while admin 1 is logged in
	Calibration lock open while admin 2 is logged in

3. A user/administrator logging in/out

A total of five different users and two administrators are available for log-in.

User rights



- The rights of the five saved users are identical, i.e. these users all have the same level of access rights.
- An individual password can be created for each user.
- Each user has change access to parameters marked with the corresponding icon in the **access** column of the menu page at parameter level (cf. section 7.4 "Controls in the display field").



- Some parameters that require administrator access rights to be modified are displayed to a logged-in user on the menu pages, but cannot be changed by them. Other parameters that require administrator rights are hidden and therefore **not** visible to the logged-in user.

Admin rights



- The rights of the two saved admins are identical, i.e. these admins all have the same level of access rights.
- An individual password can be created for each admin.
- Each admin has change access to parameters marked with the corresponding icon in the **access** column of the menu page at parameter level (cf. section 7.4 "Controls in the display field").

To log in a user/admin, proceed as follows:

- ▶ Press the **User log-in** button.
 - ➔ The user log-in window will open (cf. fig. 48)

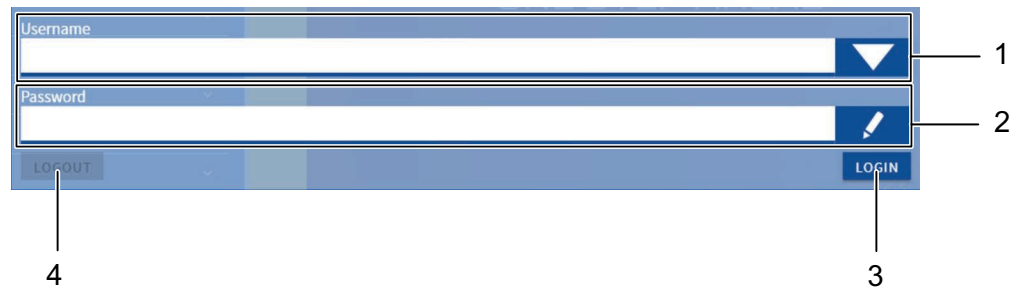

Fig. 48: User log-in window

No.	Designation	Function
1	Username selection	<ul style="list-style-type: none"> Open the selection list and select the required user: <ul style="list-style-type: none"> User 1, User 2, User 3, User 4, User 5 Admin 1, Admin 2
2	Password input	<ul style="list-style-type: none"> Open the input window for the password (cf. fig. 49) <ul style="list-style-type: none"> The default setting of the password for all users/admins is: User1
3	Log-in button	<ul style="list-style-type: none"> Confirm the log-in details (user and password)
4	Log-out button	<ul style="list-style-type: none"> Log out the current user (This button can only be used if a user has logged in.)

- ▶ Select the required user or admin from the **Username** selection.
 - ➔ The selected user is displayed in the selection.
- ▶ Select **Password** input.
 - ➔ An input window will open (cf. fig. 49).

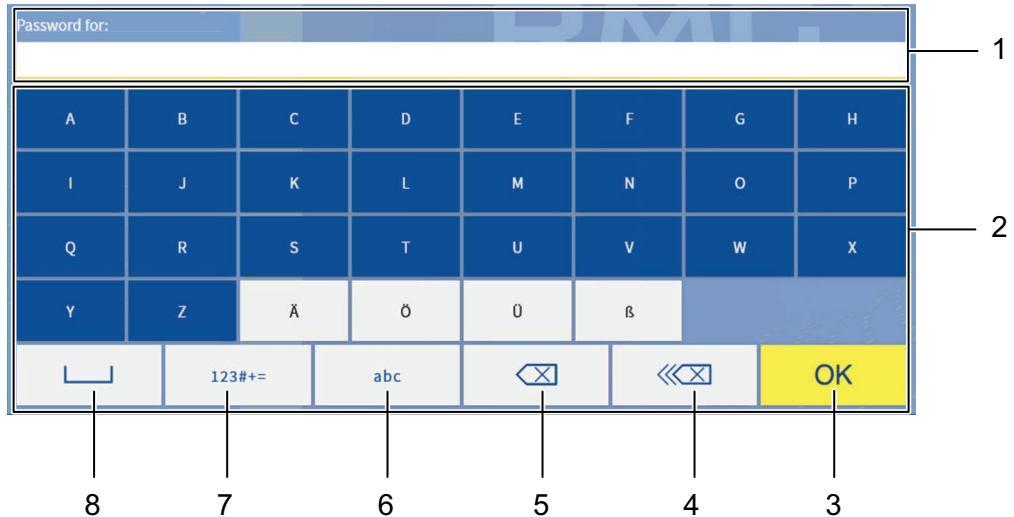

Fig. 49: Password input window

No.	Designation	Function
1	Input field Password	<ul style="list-style-type: none"> ■ Display of the entered characters
2	Letters/numbers and symbols field	<ul style="list-style-type: none"> ■ Keyboard function
3	OK button	<ul style="list-style-type: none"> ■ Confirm the entry and log in the user
4	Delete entry button	<ul style="list-style-type: none"> ■ Clears the entire input field
5	Delete character button	<ul style="list-style-type: none"> ■ Deletes the last character in the input field
6	Shift button	<ul style="list-style-type: none"> ■ Toggles between upper case and lower case letters ■ Toggles between numbers and symbols
7	Selection button	<ul style="list-style-type: none"> ■ Select between display of numbers/symbols and letters
8	Space button	<ul style="list-style-type: none"> ■ Enters a space in the password input field

- ▶ First enter the password **User1** (default setting) and press **OK** to confirm.
 - ➔ The selected user is logged in.

NOTE

Password change on initial start-up

The RFC 7 is delivered with the password User1 (default setting) for all users and admins. During initial start-up, the passwords must be assigned/changed individually.

- ▶ Assign new passwords as described below.

Changing passwords

To change the password of a user/admin, proceed as follows:

- ▶ First log in the user/admin whose password you want to change, as described above.
- ▶ Press the **User log-in** button to open the log-in window again.
 - ➔ The **Change password** button is now displayed in the log-in window.
- ▶ Press the new **Change password** button.
 - ➔ The **Set new password** window will open (cf. fig. 50).



Fig. 50: Set new password window

No.	Designation	Function
1	New password input	<ul style="list-style-type: none"> Open the input window for the new password (cf. fig. 49)
2	Confirm new password input	<ul style="list-style-type: none"> Open the input window for confirming the new password (cf. fig. 49)
3	BACK button	<ul style="list-style-type: none"> Jump back to the log-in window
4	SET NEW PASSWORD button	<ul style="list-style-type: none"> Set the new password

- ▶ Enter the new password into the two input fields (fig. 50, nos. 1 and 2) and click the corresponding button (fig. 50, no. 4) to set the password.

7.3.2 Set language

In the web view, the header contains a separate button that you can use to temporarily select the language from a selection menu (cf. fig. 46, no. 6).

To select the general system language, proceed as follows:

- ▶ Select section **9. System settings**.
- ▶ Navigate to the last menu page and select the subsection **9.450 Device parameters**.
- ▶ In the coordinates selection menu **9.450.30 System language**, you can select your preferred language.

7.3.3 Messages

The **Messages** button has two functions.

1. Display the message with the highest priority

The displayed icons have the following meanings and are listed below in order of priority, from high to low:

Icon	Designation	Meaning
	Alarm	There is an active alarm message, which has been added to the message list.
	Warning	There is an active warning message, which has been added to the message list.
	Note	There is an active note message, which has been added to the message list.
	OK+	There are only inactive messages, which has been added to the message list.
	OK	There are no messages.

2. Open the message list

Clicking the **Messages** button opens the message list.



Fig. 51: Message list

No.	Designation	Function
1	Tick	■ Delete inactive messages
2	Status	■ Display message status
3	Category	■ Display message category
4	No.	■ Display message number
5	Time	■ Display date/time when the message was issued
6	Description	■ Display the message/window description

In the status field, the type of message is also indicated by colour coding:



	Alarm active (red)
	Warning active (yellow)
	Note active (blue)
	Message inactive (grey)

7.3.4 Favourites

The **Favourites** button can only be used if a user has logged in. It has two functions.

1. Display whether the current menu page has been added to the favourites list.

The icons displayed have the following meanings:



	Current menu page is not a favourite.
	Current menu page is a favourite.

2. Open the favourite list

Clicking the **Favourites** button opens the favourites list. A favourite can be selected in the list to be displayed or the current page can be saved as a favourite.

A maximum of seven favourites can be saved in the list. To save an additional favourite, you first need to delete one of the existing favourites.

The following buttons are available:

	Add current menu page as a favourite
	Remove favourite

7.4 Controls in the display field

The controls in the display field are generally identical on the touchscreen and in the web view and will be described together.

They will be explained on the basis of the web view. If the controls are displayed differently on the touchscreen, the differences will be described.

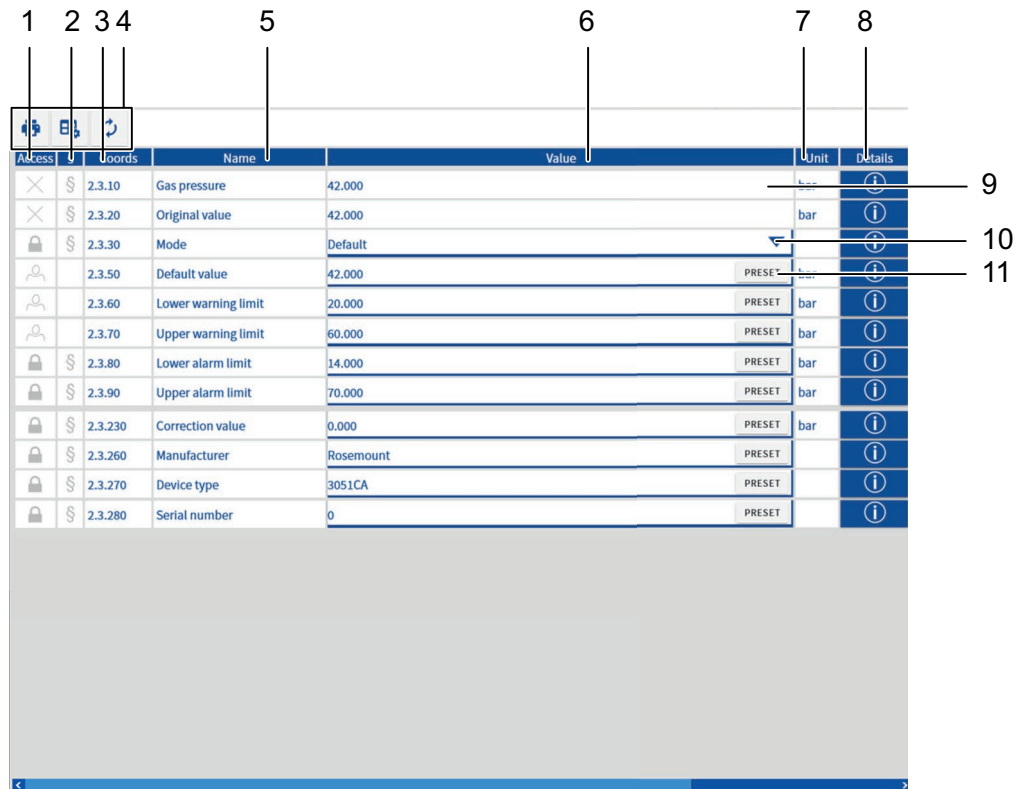









Fig. 52: Web view, display field

No.	Designation	Function
1	Access column	<ul style="list-style-type: none"> Display the access rights needed to change the parameter
2	§ column	<ul style="list-style-type: none"> Display whether the parameter is used for an official calibration measurement.
3	Koo column	<ul style="list-style-type: none"> Display the corresponding coordinates of the parameter
4	Buttons (only in web view)	<ul style="list-style-type: none"> Functions: <ul style="list-style-type: none"> - Change column selection - Print parameter page - Save entry (only visible after data has been entered) - Discard entry (only visible after data has been entered)
5	Name column	<ul style="list-style-type: none"> Designation of the parameter
6	Value column	<ul style="list-style-type: none"> Value of the parameter
7	Unit column	<ul style="list-style-type: none"> Unit of the parameter
8	Detail column	<ul style="list-style-type: none"> Open and close a window with detailed information on the corresponding parameter, e.g. the default value
9	Display field	<ul style="list-style-type: none"> No entry, display only

No.	Designation	Function
10	Selection field	<ul style="list-style-type: none"> ■ Selection menu for input
11	Input field	<ul style="list-style-type: none"> ■ Input <ul style="list-style-type: none"> - Via keyboard (web view) - Via default button (web view) - Via input dialogue window (touch-screen)

Access column (no. 1)

The access column indicates whether the corresponding parameter can be changed and what access rights are needed to do so:

	Parameter cannot be edited/changed.
	Parameter can be edited/changed without restrictions.
	Parameter can be edited/changed with user rights.
	Parameter can be edited/changed with admin rights.
	Parameter can only be edited/changed when the calibration lock (software or hardware lock) is open.
	Parameter can only be edited/changed when the calibration lock is open and an administrator is logged in.
	Parameter can only be changed when the calibration lock (only hardware lock) is open.

§ column (no. 2)

This column indicates whether the corresponding parameter can be used in applications involving official calibration:

	Parameter or measured value is officially calibrated.
---	---

Koo column (no. 3)

Every parameter can be uniquely identified or allocated by means of its coordinates. Coordinates are structured as follows:

- Section.subsection.parameter-number

Example: 2.3.50 'Default value'

- ➔ 2.= section 2. Conversion
- ➔ 3.= subsection 3. Gas pressure
- ➔ 50= parameter number
- ➔ 'Name of the parameter, here: Default value'

Buttons (no. 4)

These buttons are only displayed in the web view. They have the following functions.

	Change column selection
	Print parameter page (please observe the note below)
	Deactivate automatic refresh
	Save entries (this icon is only visible if one or more entries have been made – entries are also displayed with a coloured background and can be saved jointly.)
	Discard entries (this icon is only visible if one or more entries have been made)

On the touchscreen, any changed entries are saved automatically!

NOTE

Printing the Parameter Page – Printer Window

When the **Print Parameter Page** button is pressed, a separate printer window opens in the web view. Depending on the web browser used, it may happen that this window opens in the background. In this case, the RFC 7 can no longer be operated in the web view!

- ▶ Minimise the RFC 7 web-view window to gain access to the printer window.
- ▶ Carry out the printing process by pressing the corresponding button in the printer window.
- ▶ The printer window will then close automatically, and the RFC 7 will once again be operable in the web view.

Detail column (no. 8)

The Detail column contains an info button for each parameter (cf. fig. 53).



Fig. 53: Info button

Pressing this button opens a detailed info window underneath the line of the selected parameter containing information on the parameter/coordinate. Its contents include the default value and the internal system name for the parameter (fig. 54, no. 2). Pressing the **Close** button (fig. 54, no. 1) closes the detailed info window and the info button is once again displayed in the corresponding line.

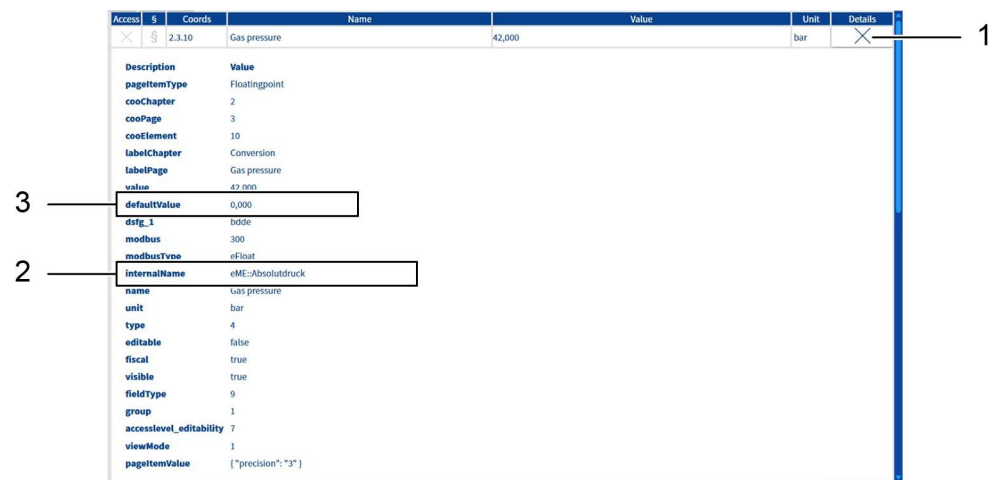

Fig. 54: Detailed info window for the parameter '2.3.10 Gas pressure'

No.	Designation	Function
1	Close button	<ul style="list-style-type: none"> Close the detailed info window
2	Internal name	<ul style="list-style-type: none"> Displays the system's internal name for this parameter; can be used to assign a measured value to an analogue output, for example. In the web view, this name can be entered at another location by using the copy & paste function.
3	Default value	<ul style="list-style-type: none"> Display the preset value for the selected parameter

Field Selection (no. 10)

Clicking the arrow in the selection field opens a selection menu that displayed all the available selection options (cf. fig. 55). The saved default value is always shown in bold in the selection menu.

Access	Coords	Name	Value	Unit	Details
🔒	2.1.10	Gas pressure	bar	x	ⓘ
🔒	2.1.20	Gas temperature	bar	x	ⓘ
🔒	2.1.30	Gas components	Kilopond / cm2	x	ⓘ
🔒	2.1.40	Calorific value	PSI	x	ⓘ
🔒	2.1.50	Standard density	MPa	x	ⓘ
🔒	2.1.60	Operating volume flow	kPa	x	ⓘ
🔒	2.1.70	Standard volume flow	bar a	x	ⓘ
🔒	2.1.80	Energy flow	Pa	x	ⓘ
🔒	2.1.90	Mass flow	hPa	x	ⓘ
🔒	2.1.100	Kv factor	kg/h	x	ⓘ
			Pulses/m3	x	ⓘ

Fig. 55: Selection menu for coordinate 2.1.10 Gas pressure unit

Input field (no. 11)

In the **web view**, input values can simply be entered with the keyboard after you have selected a field of the type 'input'. Alternatively, you can enter the default value (visible in the detailed info window) by clicking the **Default** button.



To apply the entered values, you need to save them by clicking the corresponding button. If more than one value has been changed, a window opens automatically where you can save or discard the changes.

There are still 2 unsaved changes that would be lost.

List of affected changes

	Changed Field	Old Value	New Value
1	Start software update	No	Yes
2	Complete / restart software update	No	Yes

Do you really want to leave the page?

DISCARD CHANGES
SAVE CHANGES

Fig. 56: Save changes window

On the **touchscreen**, when you select a field of the type 'input', an input dialogue window opens (cf. fig. 57).

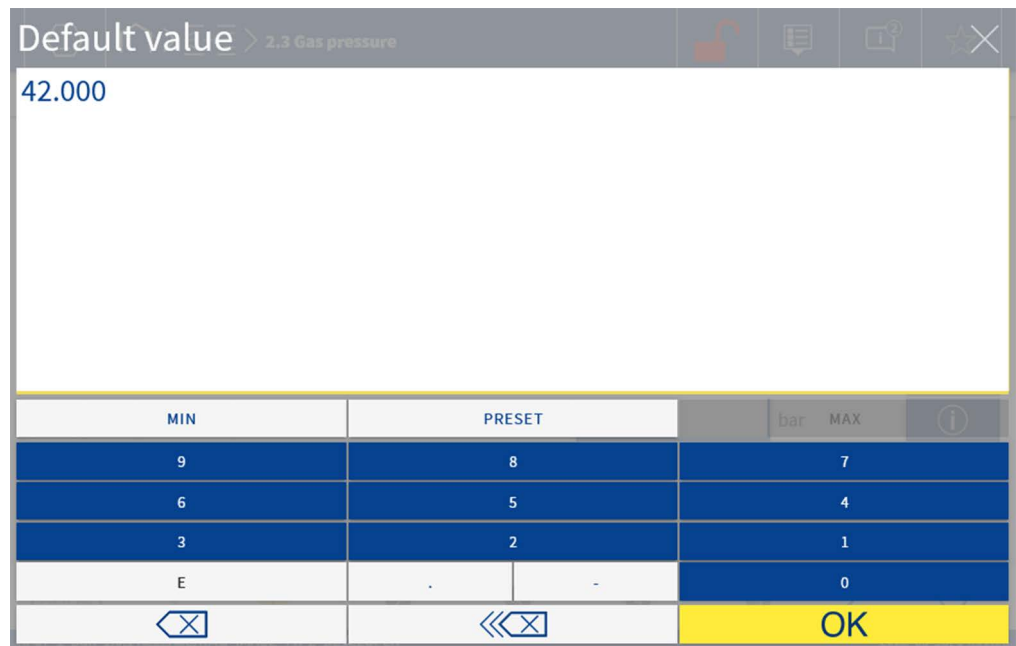

Fig. 57: Input dialogue window

The input value can be entered here either by using the numeric keypad or you can enter the default value by clicking the **Default** button. Clicking the **OK** button confirms and saves the entry and the window closes automatically.

7.5 Overview of the available menu pages

The following table provides an overview of the available menu pages and their structural arrangement.

NOTE

Display of menu '2. Conversion'

The menu **2. Conversion** is only displayed in the web view and on the touchscreen when a user is logged in!

Section level		Subsection level		Parameter level Touchscreen Page number
Icon	Designation	Icon	Designation	
	1. Overviews		1.20 Analysis	1
			1.30 Measurement values	1
			1.40 Counters	5
			1.50 Flow	2

Table 15: Overview of menu pages

Section level		Subsection level		Parameter level Touchscreen Page number
Icon	Designation	Icon	Designation	
			1.70 Output/input	5
			1.80 Nameplate	1
	2. Conversion		2.1 Units	3
			2.2 Formats	4
			2.3 Gas pressure	5
			2.4 Gas temperature	5
			2.5 Flow rate parameters	5
			2.6 Flow rate at measured conditions	4
			2.7 Corr. flow rate at measured conditions	3
			2.8 K coefficient	6
			2.9 Flow rate at base conditions	3
			2.10 Energy flow	3
			2.11 Mass flow	1
			2.12 CO ₂ emission mass flow	1
			2.17 Counter mode	3
			2.100 Counters – billing mode 1	5
			2.200 Fault counters – billing mode 1	5

Table 15: Overview of menu pages

Section level		Subsection level		Parameter level
Icon	Designation	Icon	Designation	Touchscreen Page number
			2.300 Counters – billing mode 2	5
			2.400 Fault counters – billing mode 2	5
			2.500 Counters – billing mode undefined	6
			2.800 Cycle quantities	2
	3. Gas quality (GQ)		3.10 GQ setting	5
			3.20 Current GQ	8
			3.30 Lower QG warning limits	4
			3.40 Upper GQ warning limits	4
			3.50 GQ default	4
			3.60 Main GQ Modbus client	30
			3.70 Replacement GQ Modbus client	30
			3.80 Main GQ Modbus server	4
			3.90 Replacement GQ Modbus server	4
			3.100 ISO 6976 GQ	1
	4. Volume encoder		4.12 Meter factor	1
			4.14 Characteristic curve	7
			4.15 Modbus client/F instance	61

Table 15: Overview of menu pages

Section level		Subsection level		Parameter level Touchscreen Page number
Icon	Designation	Icon	Designation	
			4.100 Counter readings F instance	5
			4.500 Synchronisation monitoring	3
	5. Outputs		5.100 Digital output 1 (DO1)	1
			5.101 Digital output 2 (DO2)	1
			5.110 Digital output 3 (DO3)	1
			5.111 Digital output 4 (DO4)	1
			5.112 Digital output 5 (DO5)	1
			5.113 Digital output 6 (DO6)	1
			5.200 Analogue output 1 (AO1)	3
			5.201 Analogue output 2 (AO2)	3
			5.202 Analogue output 3 (AO3)	3
			5.203 Analogue output 4 (AO4)	3
	6. Inputs		6.10 Digital input 1 (DI1)	1
			6.11 Digital input 2 (DI2)	1
			6.12 Digital input 3 (DI3)	1
			6.13 Digital input 4 (DI4)	1
			6.100 Analogue input 1 with HART (AI1)	2
			6.101 Analogue input 2 with HART (AI2)	2

Table 15: Overview of menu pages

Section level		Subsection level		Parameter level Touchscreen Page number
Icon	Designation	Icon	Designation	
			6.102 Analogue input 3 (AI3)	2
			6.114 Analogue input 4 with HART (AI4)	2
			6.115 Analogue input 5 with HART (AI5)	2
			6.120 PT100 Non-Ex	3
			6.121 PT100 Ex	3
			6.200 Frequency and pulse input 1	2
			6.201 Frequency and pulse input 2	1
			6.300 Encoder settings	8
	7. User data		7.10 Measurement location details	1
	8. Check		8.10 Freeze	1
			8.30 Functional test	10
			8.40 Functional test result	1
			8.200 Functional test averages	26
	9. System settings		9.1 Software update (only available in web view)	1
			9.2 Time and date	2
			9.3 Time synchronisation	4
			9.4 Memory management	1

Table 15: Overview of menu pages

Section level		Subsection level		Parameter level Touchscreen Page number
Icon	Designation	Icon	Designation	
			9.7 Serial interfaces	6
			9.9 Firewall	3
			9.11 Ethernet 1	7
			9.12 Ethernet 2	7
			9.13 Ethernet 3	7
			9.14 Ethernet 4	7
			9.15 Ethernet 0 internal	3
			9.20 Modbus server	5
			9.60 IOC	2
			9.100 Access rights	4
			9.110 User management	9
			9.250 Software ID	5
			9.400 System info HW/OS	14
			9.410 Screen/screensaver	2
			9.450 Device parameters	
			9.500 System	9
	11. Peal load		11.10 Max. hour/day and month	4
			11.20 Max. gas day/month	3

Table 15: Overview of menu pages

Section level		Subsection level		Parameter level Touchscreen Page number
Icon	Designation	Icon	Designation	
	12. Factory settings		12.10 Set counters	5
			12.20 Deletions	2
	40. DSfG archive		40.10 AG 1 counter + measured values AM1	5
			40.20 AG 2 – fault counter AM1	5
			40.30 AG 3 – counter + measured values AM2	5
			40.40 AG 4 – fault counter AM2	5
			40.90 AG 9 – Modbus client for USM 1b	
			40.100 AG 10 – Modbus client for USM 2a	
			40.110 AG 11 – Modbus client for USM 2b+c	
			40.120 AG12 – gas quality	2
			40.130 AG 13 – counter for undefined AM	5
			40.170 AG 17 – functional test part 1	1
			40.180 AG 18 – functional test part 2	1
			40.190 AG 19 – functional test part 3	1
			40.220 AG 22 – Peak load gas day	1
			40.230 AG 23 – Peak load gas month	1

Table 15: Overview of menu pages

Section level		Subsection level		Parameter level Touchscreen Page number
Icon	Designation	Icon	Designation	
			40.500 AG 50 – official calibration logbook	1
			40.510 AG 51 – non-official calibration logbook	3
	50. Miscellaneous		50.10 Error messages	3
			50.850 Error log	1
			50.851 Temporary error log	1
			50.860 Flash IOC log	1
			50.870 Mount log	1
			50.900 Header	2
	100. IO controller (This menu is intended solely for service and diagnostic purposes and is always displayed in English, regardless of the system language setting.)		100.1 Digital inputs	9
			100.2 Current inputs 1-3, PT100_EX	10
			100.3 Current inputs 4, 5 PT100_NonEx	9
			100.5 Digital outputs	11
			100.6 Current outputs	4
			100.7 Encoder	5
			100.8 System values	4
			100.9 Communication	2
			100.26 System information	10

Table 15: Overview of menu pages

8 Commissioning

8.1 General commissioning instructions

Before commissioning, ensure that all the safety instructions listed have been observed and that both the installation of the RFC 7 itself and the connection of all required devices and sensors have been carried out in accordance with the information provided in this manual.

During commissioning, the explosion protection regulations and all the safety instructions for working in potentially explosive atmospheres also apply.

Wherever possible, commissioning is performed at the factory and, if necessary, additionally on site by qualified technicians or field service staff. RMG offers training and commissioning services for this purpose.

All newly delivered devices come with factory parameter settings, which may already have been configured in line with the customer's requirements. As a rule, these parameter settings will be sufficient. Some on-site adjustments to settings and parameters using the user interface may, however, still be required. Initially, only those parameters that are not protected by the calibration switch can be modified.

If local conditions make it necessary to change parameters that are protected by the calibration switch, this may only be carried out by individuals who have received authorisation from the inspection authority or by calibration officers.

NOTE

Fiscal application

If the Flow Computer RFC 7 is intended for an fiscal application, it is preset at the factory in accordance with the type approval before delivery and secured against unauthorised modification by means of lead seals and software and hardware interlocks. The type approvals applicable to the device and its function are listed on the rating plate. If the lead seals or safeguards are removed or damaged, the RFC 7 loses its type approval and may no longer be used for fiscal applications.

- ▶ Never remove or damage the lead seals or other safeguards.
- ▶ If a safeguard nevertheless has to be removed or has been damaged, an inspection by a state-approved body or by a calibration officer is required, together with any further inspection of the other settings at the factory. Once the device has been re-locked, the calibration officer must reapply the lead seals before the RFC 7 may be put back into use for fiscal applications.

NOTE

Acceptance certificate

An acceptance certificate must be prepared during commissioning to document the fact that the device has been commissioned correctly and any settings have been applied.

The following sections also describe how to set parameters that are protected by the calibration switch. These settings should only be made by individuals with the appropriate authorisation. You can identify which parameters are protected by the calibration switch from the **Access** column on each parameter-level menu page (see section 7.4 "Controls in the display field").

The menu pages shown in the following sections reflect the view of a logged-in administrator. Administrators have the highest authorisation level and are therefore shown all available fields and options.

Users with a lower authorisation level may see different views, as certain fields and functions are hidden from them. Depending on which user is logged in, the display on the device or PC may therefore differ from the menu pages shown in this manual.

8.2 Prerequisites for commissioning

Before commissioning may be carried out, the installation must have been inspected in accordance with the following ordinances, regulations and standards:

- Section 15 of the German Ordinance on Industrial Safety and Health (BetrSichV): 'Inspection prior to commissioning and prior to recommissioning following modifications that are subject to inspection'
- DGUV Regulation 3 entitled 'Electrical installations and equipment', Section 5: 'Inspections'
- VDE 0100-100 entitled 'Low-voltage electrical installations'
- DIN EN 60079-14 VDE 0165-1 entitled 'Explosive atmospheres'

8.3 Carrying out commissioning

Commissioning can be carried out either using the touchscreen or using a PC or notebook over a network connection.

The settings are very easily made using the browser available on the PC (e.g. Microsoft Edge, Mozilla Firefox, etc.).

- ▶ Commissioning using a PC is recommended, and is therefore described in the following sections.



Detailed information on the user interface on the touchscreen and PC and how to use it can be found in section 7 "User Interface Operation".

8.3.1 Establishing a network connection

The network connection between the RFC 7 and a PC or notebook can be established in the following ways:

- **Local:** A network cable (LAN cable) is connected to one of the Ethernet interfaces Eth 1 – 4 on the rear panel of the device and to an Ethernet interface on the PC or notebook (a direct connection).
- **Remote:** The RFC 7 is connected from one of the Ethernet interfaces Eth 1 – 4 on the rear panel of the device to an existing network using a network cable (LAN cable).

NOTE**Integrating the RFC 7 into an existing network**

To be able to integrate the RFC 7 into an existing network, the network must allow third-party devices to be added. Protected company networks may prevent this.

- ▶ Consult with your IT department to find out how the RFC 7 can be integrated into your company network.

NOTE**Using the RFC 7 with different networks at the same time**

The RFC 7 can be used with up to four networks at the same time over Ethernet interfaces 1 – 4. A connection between the different networks is prevented by software in combination with correctly configured routes.

- ▶ Consult with your IT department to find out the correct routing configuration.

To integrate the RFC 7 into a network (local or remote), it must be assigned an IP address. Two options are available:

- **Static IP address**
You can assign the RFC 7 a fixed IP address. This remains permanent and is suitable for environments where a constant network address is required.
- **Dynamic IP address (DHCP)**
Alternatively, the RFC 7 can obtain its IP address automatically from a DHCP server on the network. In this case, the address, routes and DNS are assigned dynamically and may change when the DHCP lease is renewed.

Procedure when using a static IP address:

After the power supply has been connected to the RFC 7, the device boots up automatically and the start menu appears on the touchscreen. The use of a static IP address is explained below using the Ethernet interface ETH 1 as an example. The same procedure applies to all the other Ethernet interfaces.

1. Depending on which of the RFC 7's Ethernet interfaces the network is connected to, navigate to the corresponding menu page on the device, in this case **9.11 Ethernet 1**.
 - ➔ The currently active IP address is shown at coordinate **9.11.30 ETH1 IP4 (current)**.

Access	§	Coords	Name	Value	Unit	Details
		9.11.20	Set ETH1 IP4	10.99.1.11		
		9.11.30	Current ETH1 IP4	10.99.1.11		
		9.11.40	ETH1 MAC	00:1E:C0:D1:AE:C4		
		9.11.50	ETH1 state	ROUTABLE		
		9.11.60	Bytes / packets / errors / drops rece...	3512223/13579/0/0		
		9.11.70	Bytes / packets / errors / drops sent	10791705/10523/0/0		
		9.11.71	Allow ETH1 http	Yes		

Fig. 58: Menu 9.11 Ethernet 1 on the touchscreen

- To specify that a static IP address is to be used, navigate to the next page, to coordinate **9.11.75 DHCP (set)**. The following settings can be selected here:
 - Yes:** The IP address is assigned automatically by a DHCP server on the network.
 - No:** The IP address must be entered manually, as it is not obtained from a DHCP server.
- Select the setting **No**. You can now enter a static IP address for the RFC 7 manually at coordinate **9.11.20**.

Access	§	Coords	Name	Value	Unit	Details
		9.11.72	Allow ETH1 https	Yes		
		9.11.73	Allow ETH1 SSH	Yes		
		9.11.75	Set ETH1 DHCP	No		
		9.11.80	Current ETH1 DHCP	No		
		9.11.90	Ignore ETH1 DHCP routes	No		
		9.11.91	Ignore ETH1 DHCP DNS	No		
		9.11.100	Set ETH1 MTU	1500		

Fig. 59: Menu 9.11 Ethernet 1 – page 2 on the touchscreen

- Also ensure that the subnet is correctly defined at coordinate **9.11.130 ETH1 prefix length (current)**. If necessary, change the setting at coordinate **9.11.120 ETH 1 prefix length (set)**. The table below shows the most common settings:

Prefix length	Subnet mask	Number of IP addresses	Typical use
8	255.0.0.0	16,777,216	Large networks
16	255.255.0.0	65,536	Medium-sized networks
24	255.255.255.0	256	Local networks

Table 16: Common prefix lengths

5. To access the RFC 7 from the PC's browser, set one or both of the following coordinates to **Yes**, depending on the type of connection you wish to use:
 - 9.11.71 ETH1 allow http
 - 9.11.72 ETH1 allow https

If the RFC 7 is accessed over the Modbus server, the relevant Ethernet interface used for the connection must be activated in the menu **9.20 Modbus server** (here, coordinate 9.20.100 ETH1 active).

If the RFC 7 is accessed over DSfG-B, the setting **Yes** must be selected at coordinate **9.40.180 DSfG active** in the menu **9.40 DSfG subscriber 1**. This selection then applies to all Ethernet interfaces (ETH1 – ETH4).

6. For the protocols mentioned above (http and https) to be executed, the associated ports (coordinates **9.9.20** and **9.9.30**) must be entered for release in the menu **9.9 Firewall**.
 - ▶ If the RFC 7 is accessed over the Modbus server, enter the port at coordinate **9.20.40 Modbus server ETH port** in the menu **9.20 Modbus server**.
 - ➔ The entered port is shown at coordinate **9.9.40** in the menu **9.9 Firewall**.
 - ▶ If the RFC 7 is accessed over DSfG-B, enter the port at coordinate **9.9.130 Port DSfG-B IP** in the menu **9.9 Firewall**.
 - ➔ If no port is entered at a coordinate (i.e. the value is zero), the associated protocol is disabled.
 - ➔ At coordinates **9.9.140** to **9.9.170**, the menu **9.9 Firewall** lists which ports are entered or activated for each Ethernet interface.
7. Now enter the IP address in the browser's address bar (URL bar) and confirm by pressing the Enter key on your keyboard.
 - ➔ The web view of the user interface appears in the browser.

The procedure described above covers connection from within the same subnet, i.e. no (default) route is required.

Using the encrypted https connection

When you connect to the RFC 7 over https, a security warning may appear with the message '**Your connection is not private**' or '**The website is not secure**'. This is because the flow computer is addressed by means of its numerical IP address and uses its own security certificate, which is not classified as trusted by the web browser.

Proceed as follows to establish a secure connection:

- ▶ In the security warning displayed, select the option '**Advanced**' or '**More information**'.
- ▶ Select '**Continue to <IP address> (unsafe)**' or an option to the same effect.
 - ➔ The connection is now established in encrypted form over https.
 - ➔ The web view of the user interface appears in the browser.

NOTE

Information on the security certificate

The RFC 7 uses a self-signed security certificate that has not been issued by a public certification authority (CA).

- The encryption of data transmission is nevertheless **active and secure**.
- The browser warning indicates that the device’s identity cannot be automatically confirmed. The reason for this is that the connection is established over a numerical IP address rather than a host name, and that the security certificate used is not issued by a public certification authority. The browser therefore classifies the certificate as untrusted.

Setting up a static route

To integrate the RFC 7 into more complex networks, it may be necessary to define static routes. The simplest application is to define just one default route, which instructs the RFC 7 to send all data packets that are not destined for the local subnet to a defined gateway.

NOTE

Using multiple Ethernet interfaces and networks

If multiple interfaces are to be used, the routes determine which interface data packets are sent over. Incorrectly set routes can result in data packets being sent over the wrong interface or not arriving at all.

- ▶ Consult with your IT department to find out the correct routing configuration.

Proceed as follows to set up a single static route (the description below is given for route 1 as an example):

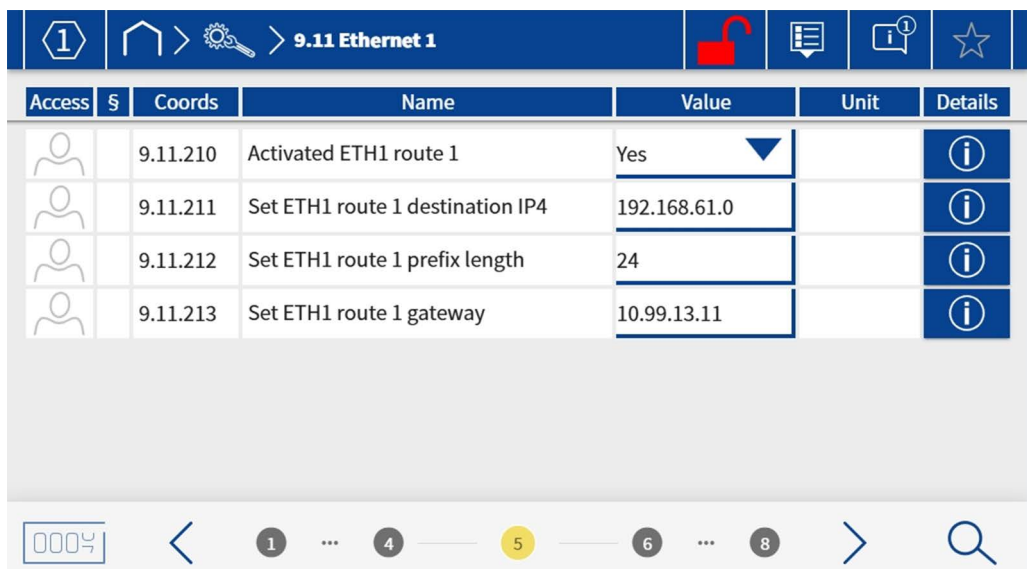

Fig. 60: Menu 9.11 Ethernet 1 – page 5 on the touchscreen

1. At coordinate **9.11.211 ETH1 route 1 destination IP4 (set)**, enter the destination IP address or the destination network you wish to reach.
Examples:
 - 192.168.100.10, single destination IP

- 192.168.100.0, entire destination network
- 2. At coordinate **9.11.212 ETH1 route 1 prefix length (set)**, define the subnet mask or the size of the destination network (also see Tabelle 16).
Examples:
 - Prefix length 24 = subnet mask 255.255.255.0 (network size 256 addresses)
 - Prefix length 16 = subnet mask 255.255.0.0 (network size 65,536 addresses)
- 3. At coordinate **9.11.213 ETH 1 route 1 gateway (set)**, enter the gateway address. Note that the gateway address must lie within the local subnet.
- 4. Finally, enter the IP address of the DNS server at coordinate **9.11.270 ETH1 DNS 1 IP4 (set)**.
- 5. To ensure failover, you can additionally configure a second DNS server at coordinate **9.11.271 ETH 1 DNS 2 IP4 (set)**.
- 6. Activate the route by selecting the setting **Yes** at coordinate **9.11.210 ETH1 route 1 activated**.

NOTE

Configuring the DNS server

A DNS (Domain Name System) server is used to translate host names into IP addresses. This makes it possible to use a memorable name (e.g. server.mycompany.com) instead of an IP address.

If, for example, an SNTP time server is to be addressed by a host name for time synchronisation purposes, configuration of the DNS server is essential.

Procedure when using a dynamic IP address

When a dynamic IP address is obtained from a DHCP server, the server automatically supplies many of the settings described above. For this to work without any errors, the following settings must be selected (using ETH 1 as an example):

1. Navigate to the second page of the menu **9.11 Ethernet 1** and select the setting **Yes** at coordinate **9.11.75 DHCP (set)** (see fig. 59).
 - ➔ The RFC 7 now obtains its IP address from the DHCP server on the network.
 - ➔ You can read off the address at coordinate **9.11.30 ETH1 IP4 (current)**.
2. At coordinate **9.11.90 ETH 1 ignore DHCP routes**, select the setting **No**.
 - ➔ The routes automatically supplied by the DHCP server are used.
3. At coordinate **9.11.91 ETH 1 ignore DHCP DNS**, select the setting **No**.
 - ➔ The DNS server addresses automatically supplied by the DHCP server are used.
4. The further procedure follows the description from [<Step no. 5>](#) in section [<Procedure when using a static IP address>](#).

8.3.2 User login

To make parameter or commissioning settings, a user with the appropriate authorisation must be logged in.

- ▶ Log in as a user with the corresponding password.

On delivery, all users and admins have the password **User1**.

- ▶ Please set new passwords when logging in for the first time and document them. Keep the list of passwords in a safe place and only issue passwords in accordance with the necessary authorisation level.



Detailed information on user login and changing passwords can be found in section 7.3.1 "User log-in".

8.4 Entering user data

8.4.1 Entering measurement location details

First of all, enter the required information about the measurement location. Proceed as follows to do this:

- ▶ Navigate to the menu page **7.10 Measurement location details**.

Access	Coords	Name	Value	Unit	Details
	7.10.10	Measurement type	Main measurement		
	7.10.20	Billing	Billing measurement		
	7.10.30	Name of pipeline	1.1H <input type="text" value="PRESET"/>		
	7.10.40	Measurement location	Bdh <input type="text" value="PRESET"/>		
	7.10.50	Owner	Besitzer <input type="text" value="PRESET"/>		
	7.10.60	Last calibration	1970-01-01T01:00:00 <input type="text" value="NOW"/>		

Fig. 61: Menu page 7.10 Measurement location details

- ▶ At coordinate **7.10.10 Measurement type**, select whether the measuring point is a main measurement or a comparison measurement.
- ▶ At coordinate **7.10.20 Billing**, specify whether this is a 'normal' billing measurement or a reserve measurement. A reserve measurement refers, for example, to a measurement line that is not operated in summer but only in winter.
- ▶ At coordinates **7.10.30 Segment**, **7.10.40 Measurement location** and **7.10.50 Owner**, enter descriptive information about the measuring point so that it can be uniquely identified.
- ▶ At coordinate **7.10.60 Last calibration**, enter the corresponding date.
- ▶ Save your entries by clicking on the corresponding button. (See section 7.4 "Controls in the display field").

8.5 Volume conversion – defining parameters

8.5.1 Defining units

During commissioning, it is very important to correctly select units for physical input variables. Otherwise, calculations may be distorted.

Example:

If a measuring point has an operating pressure of around 100 bar, the conversion factor between the two physical variables (the flow rate at measured and at base conditions) is approximately 100.

If the unit **m³**, which is a typical unit for a volume, is then chosen for the volume at measured conditions, it is advisable to choose the unit **x100 m³** for the volume at base conditions. This selection takes into account the difference resulting from operating pressure.

$p \approx 100 \text{ bar}$; volume at measured conditions = 1 m³ → volume at base conditions = 100 m³

MWh is usually a suitable unit for energy, although a multiplier in front of the unit may also be useful for large nominal sizes and volume flow rates.

The unit **kWh** may be sufficient for small nominal sizes and volume flow rates.

Table 17 below gives an overview of recommended unit settings. The information provided in the table does not, however, release you from the obligation to check your measuring point's operating conditions and to select the units accordingly.

Operating pressure	volume at measured conditions unit	Pipe diameter	Volume at base conditions unit	Energy unit
$p \approx 100 \text{ bar}$	m ³	< DN 80	100 m ³	10 kWh or 100 kWh
$p \approx 100 \text{ bar}$	m ³	> DN 50 to < DN 150	100 m ³	MWh
$p \approx 100 \text{ bar}$	m ³	> DN 100	100 m ³	10 MWh or 100 MWh

Table 17: Recommendations for unit selection

NOTE

Note the counter overflow.

The selected units for the counters also determine how often they overflow.

- ▶ Please choose units such that, at maximum flow rate, no more than one counter overflow occurs per billing period. The counters have up to 14 digits.

Proceed as follows to select the units:

- ▶ Navigate to the menu page **2.1 Units**.

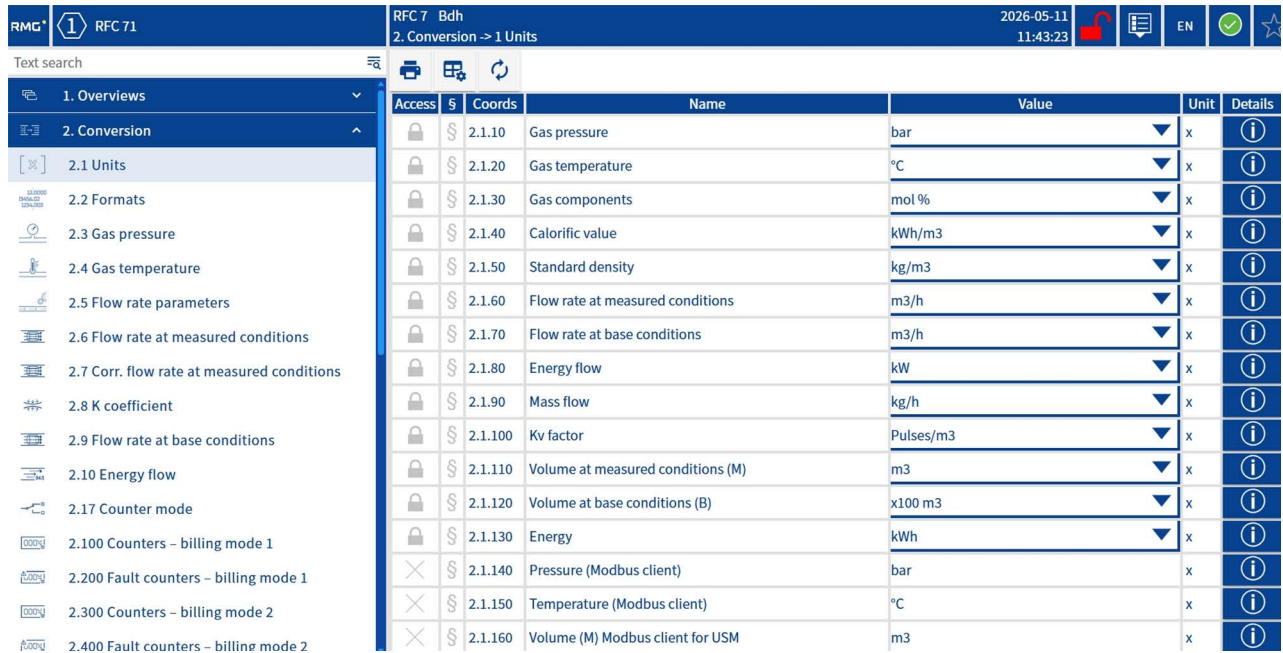

Fig. 62: Menu page 2.1 Units

- For each physical input variable (**coordinates 2.1.10 to 2.1.130**), select the required unit using the dropdown menu.

The table below shows the available unit selections:

Coordinate	Name	Available units
2.1.10	Gas pressure	<ul style="list-style-type: none"> ■ bar ■ kp/cm² ■ psi ■ MPa ■ kPa ■ bar a ■ Pa ■ hPa
2.1.20	Gas temperature	<ul style="list-style-type: none"> ■ °C ■ °F ■ K ■ R
2.1.30	Gas components	<ul style="list-style-type: none"> ■ mol %
2.1.40	Calorific value	<ul style="list-style-type: none"> ■ MJ/m³ ■ kWh/m³ ■ Mcal/m³ ■ MJ/m³ ■ BTU/ft³ ■ kcal/m³
2.1.50	Standard density	<ul style="list-style-type: none"> ■ kg/m³ ■ lb/ft³
2.1.60 2.1.70	Flow rate at measured conditions Flow rate at base conditions	<ul style="list-style-type: none"> ■ m³/h ■ ft³/h ■ m³/s ■ ft³/s ■ mft³/h ■ mmft³/h

Table 18: Overview of the available units

Coordinate	Name	Available units
2.1.80	Energy flow	<ul style="list-style-type: none"> ■ kW ■ MW ■ BTU/s ■ kcal/s ■ GW ■ MJ/h ■ GJ/h ■ TJ/h ■ kBTU/h ■ kBTU/s
2.1.90	Mass flow	<ul style="list-style-type: none"> ■ kg/h ■ lb/h ■ kg/s ■ lb/s
2.1.100	Kv factor	<ul style="list-style-type: none"> ■ Pulses/m³ ■ Pulses/ft³
2.1.110 2.1.120	Volume at measured conditions (M) Volume at base conditions (B)	<ul style="list-style-type: none"> ■ m³ ■ ft³ ■ x10 m³ ■ x100 m³ ■ x1,000 m³ ■ mft³ ■ mmft³
2.1.130	Energy	<ul style="list-style-type: none"> ■ kWh ■ MJ ■ MWh ■ BTU ■ x10 kWh ■ x100 kWh ■ x10 MWh ■ x100 MWh ■ kcal ■ MBTU

Table 18: Overview of the available units

8.5.2 Defining formats

The format for parameters can only be changed when the calibration switch is unlocked.

Proceed as follows to select the formats:

- ▶ Navigate to the menu page **2.2 Formats**.

RMG 1 RFC 71		RFC 7 Bdh		2026-05-11 11:55:42		EN	
Text search		2. Conversion -> 2 Formats					
Access	\$	Coords	Name	Value	Unit	Details	
🔒	\$	2.2.10	Gas pressure	%0.3lf		i	
🔒	\$	2.2.20	Gas temperature	%0.2lf		i	
🔒	\$	2.2.30	Conversion factor	%0.4lf		i	
🔒	\$	2.2.40	K coefficient	%0.5lf		i	
🔒	\$	2.2.50	Compressibility factor	%0.5lf		i	
🔒	\$	2.2.60	Gas components	%0.3lf		i	
🔒	\$	2.2.70	Calorific value	%0.3lf		i	
🔒	\$	2.2.80	Density ratio	%0.5lf		i	
🔒	\$	2.2.90	Standard density	%0.4lf		i	
👤		2.2.100	Methane number	%0.0lf		i	
👤		2.2.110	Unstandardised sum	%0.4lf		i	
🔒	\$	2.2.120	Flow rate at measured conditions	%0.2lf		i	
🔒	\$	2.2.130	Volume (M) counter	%0.6lf		i	
🔒	\$	2.2.140	Flow rate at base conditions	%0.2lf		i	
🔒	\$	2.2.150	Volume (B) counter	%0.6lf		i	
🔒	\$	2.2.160	Energy flow	%0.1lf		i	

Fig. 63: Menu page 2.2 Formats

The following formats are available for each parameter in the dropdown menu:

- %0lf
- %1lf
- %2lf
- %3lf
- %4lf
- %5lf
- %6lf

The numerical figure in the selection represents the number of decimal places.

Example:

The number 12.345 is displayed as follows for the various selections:

- With %0lf as 12
- With %1lf as 12.3
- With %2lf as 12.35 (the rounding of the third decimal place is correctly taken into account here.)

Internal calculations are performed as float or double with 7 or 15 digits respectively. Therefore, 7 digits are relevant, regardless of whether they appear before or after the decimal marker.

- ▶ Even so, choose the number of decimal places sensibly.

NOTE**Changing the unit**

If a measured value (e.g. pressure) has more than 7 digits before the decimal marker, the unit chosen for the measured value is unsuitable.

- ▶ Choose a suitable unit for the measured value, e.g. MPa instead of Pa for pressure.
- ▶ Proceed as described in section 8.5.1 "Defining units" to change the unit.

Selection at coordinate 2.2.210 Decimal marker

The following selections are available in the dropdown menu of coordinate **2.2.210**

Decimal marker:

- Decimal comma
- Decimal point

NOTE**Selection of the decimal marker**

The selection of the decimal marker can easily lead to errors when numbers from English-speaking regions (which use the decimal point) are mixed with numbers from German-speaking regions (which use the decimal comma).

- ▶ Take particular care when accepting numbers from sensors used in either of these regions.

8.5.3 Gas pressure – defining parameters

The pressure sensor or transmitter can sometimes only be selected and the associated parameters can sometimes only be defined when the calibration switch is unlocked.

Proceed as follows:

- ▶ Navigate to the menu page **2.3 Gas pressure**.

Access	§	Coords	Name	Value	Unit	Details
✕	§	2.3.10	Gas pressure	42.000	bar	i
✕	§	2.3.11	Freeze	0.000	bar	i
✕	§	2.3.20	Original value	42.000	bar	i
✕	§	2.3.21	Original value freeze	0.000	bar	i
🔒	§	2.3.30	Mode	Default		i
✕	§	2.3.40	Source	0.0		i
👤		2.3.50	Default value	42.000	PRESET bar	i
👤		2.3.60	Lower warning limit	20.000	PRESET bar	i
👤		2.3.70	Upper warning limit	60.000	PRESET bar	i
🔒	§	2.3.80	Lower alarm limit	14.000	PRESET bar	i
🔒	§	2.3.90	Upper alarm limit	70.000	PRESET bar	i
✕		2.3.100	Operating mode pressure absolute	Default		i
✕		2.3.120	minute average	42.000	bar	i
✕		2.3.130	hourly average	0.000	bar	i
✕		2.3.150	Ongoing event average	42.000	bar	i
✕		2.3.160	Gas pressure event average	42.000	bar	i

Fig. 64: Menu page 2.3 Gas pressure

- ▶ At coordinate **2.3.30 Mode**, specify which input the measurement signal for the gas pressure is supplied from, or whether a default value is to be used. The available options are:
 - Default
 - Analog input 1 (AI1)
 - Analog input 2 (AI2)
 - HART 1
 - HART 2
 - Analog input 3 (AI3)
 - Analog input 4 (AI4)
 - Analog input 5 (AI5)
 - HART 4
 - HART 5
- ▶ At coordinate **2.3.50**, specify the **Default value** for the gas pressure to be used, if any.
- ▶ At coordinate **2.3.60**, specify the **Lower warning limit** for the gas pressure that a warning message is to be issued at.
- ▶ At coordinate **2.3.70**, specify the **Upper warning limit** for the gas pressure that a warning message is to be issued at.
- ▶ At coordinate **2.3.80**, specify the **Lower alarm limit** for the gas pressure that an alarm is to be issued at.
- ▶ At coordinate **2.3.90**, specify the **Upper alarm limit** for the gas pressure that an alarm is to be issued at.
- ▶ At coordinate **2.3.260**, enter the **Manufacturer** of the connected pressure sensor / transmitter.
- ▶ At coordinate **2.3.270**, enter the **Device type** of the connected pressure sensor / transmitter.
- ▶ At coordinate **2.3.280**, enter the **Serial number** of the connected pressure sensor / transmitter.

8.5.4 Gas temperature – defining parameters

The temperature sensor or transmitter can sometimes only be selected and the associated parameters can sometimes only be defined when the calibration switch is unlocked.

Proceed as follows:

- ▶ Navigate to the menu page **2.4 Gas temperature**.

Access	\$	Coords	Name	Value	Unit	Details
✕	§	2.4.10	Gas temperature	10.00	°C	i
✕	§	2.4.11	Freeze	0.00	°C	i
✕	§	2.4.20	Original value	10.00	°C	i
✕	§	2.4.21	Original value freeze	0.00	°C	i
🔒	§	2.4.30	Mode	Default		i
✕		2.4.40	Source	0.00		i
👤		2.4.50	Default value	10.00	°C	i
👤		2.4.60	Lower warning limit	-20.00	°C	i
👤		2.4.70	Upper warning limit	60.00	°C	i
🔒	§	2.4.80	Lower alarm limit	-20.00	°C	i
🔒	§	2.4.90	Upper alarm limit	60.00	°C	i
✕		2.4.100	Operating mode gas temperature	Default		i
✕		2.4.120	Minute average	10.00	°C	i
✕		2.4.130	Hourly average	10.00	°C	i
✕		2.4.150	Ongoing event average	10.00	°C	i
✕		2.4.160	Gas temperature event average	10.00	°C	i

Fig. 65: Menu page 2.4 Gas temperature

- ▶ At coordinate **2.4.30 Mode**, specify which input the measurement signal for the gas temperature is supplied from, or whether a default value is to be used. The available options are:
 - Default
 - Analog input 1 (AI1)
 - Analog input 2 (AI2)
 - HART 1
 - HART 2
 - Analog input 3 (AI3)
 - Analog input 4 (AI4)
 - Analog input 5 (AI5)
 - HART 4
 - HART 5
 - PT100 non-Ex
 - PT100 Ex
- ▶ At coordinate **2.4.50**, specify the **Default value** for the gas temperature to be used, if any.
- ▶ At coordinate **2.4.60**, specify the **Lower warning limit** for the gas temperature that a warning message is to be issued at.
- ▶ At coordinate **2.4.70**, specify the **Upper warning limit** for the gas temperature that a warning message is to be issued at.

- ▶ At coordinate **2.4.80**, specify the **Lower alarm limit** for the gas temperature that an alarm is to be issued at.
- ▶ At coordinate **2.4.90**, specify the **Upper alarm limit** for the gas temperature that an alarm is to be issued at.
- ▶ At coordinate **2.4.260**, enter the **Manufacturer** of the connected temperature sensor / transmitter.
- ▶ At coordinate **2.4.270**, enter the **Device type** of the connected temperature sensor / transmitter.
- ▶ At coordinate **2.4.280**, enter the **Serial number** of the connected temperature sensor / transmitter.

8.5.5 Flow rate – defining parameters

The parameters for the flow rate can sometimes only be defined when the calibration switch is unlocked.

Proceed as follows to define the parameters:

- ▶ Navigate to the menu page **2.5 Flow rate parameters**.

Access	Coords	Name	Value	Unit	Details
🔒	2.5.10	Min. flow rate at measured conditions	50.0 PRESET	m3/h	ⓘ
🔒	2.5.20	Max. flow rate at measured conditions	1000.0 PRESET	m3/h	ⓘ
🔒	2.5.30	Qmin high-pressure test	0.0 PRESET	m3/h	ⓘ
🔒	2.5.40	Pmin high-pressure test	0.0 PRESET	bar	ⓘ
🔒	2.5.50	Pmax high-pressure test	0.0 PRESET	bar	ⓘ
🔒	2.5.60	Meter tested	For air		ⓘ
🔒	2.5.70	Meter used	For natural gas		ⓘ
🔒	2.5.80	Volume encoder mode	HF/1-channel		ⓘ
🔒	2.5.90	Pulse source mode	PI1 / PI2		ⓘ
🔒	2.5.100	Kv factor mode (chapter 4)	Constant		ⓘ
👤	2.5.110	Active flow rate warning limits	No		ⓘ
✕	2.5.120	Main cycle pulses	0	pulse	ⓘ
✕	2.5.130	Reference cycle pulses	0	pulse	ⓘ
✕	2.5.140	Flow rate (M) main frequency	0.0	Hz	ⓘ
✕	2.5.150	Flow rate (M) reference frequency	0.0	Hz	ⓘ
✕	2.5.160	Flow detection channel	Main HF		ⓘ

Fig. 66: Menu page 2.5 Flow rate parameters

- ▶ At coordinate **2.5.10 Min. flow rate at measured conditions**, enter the minimum flow rate at measured conditions that can be reliably measured.
- ▶ At coordinate **2.5.20 Max. flow rate at measured conditions**, enter the maximum flow rate at measured conditions that can be reliably measured.
- ▶ At coordinate **2.5.30 Qmin high-pressure test**, enter the value obtained from the gas meter high-pressure test.
 - ➔ The entered value is transferred to the electronic rating plate.
- ▶ At coordinates **2.5.40 Pmin high-pressure test** and **2.5.50 Pmax high-pressure test**, enter the limits of the permitted pressure range that your measuring device is operated in.
 - ➔ The entered values are transferred to the electronic rating plate.

- ▶ At the dropdown menu of coordinates **2.5.60 Meter tested** and **2.5.70 Meter used**, select the gas that the measuring device was tested with or that it is used with. The available options are:
 - For air
 - For natural gas
 - For ethylene
 - For nitrogen
 - For hydrogen
 - For oxygen
 - See gas meter
- ▶ At the dropdown menu of coordinate **2.5.80 Volume encoder mode**, select the transfer type for the flow rate values to the RFC 7. The table below provides an overview of the possible transfer types, some of which can be combined in the dropdown menu.

Transfer type	Description of function
1-channel	Single-channel transfer of the flow rate values
2-channel	Dual-channel transfer of the flow rate values
LF	Low frequency. Since a very low frequency may be present, the actual flow rate is not calculated when low-frequency transmission is used.
HF	High frequency. This transmission type is used to calculate the actual flow rate.
Enco	Original counter, direct value from the encoder. The actual flow rate is not calculated.
Modbus client / Instance F	Digital meter reading transfer. The current flow rate is determined in an ultrasonic gas meter and transferred digitally. The digital data transfer Instance F ensures uniform, manufacturer-independent allocation of digital address data and secure transfer of all essential and required data from the measuring device.
1 to 1	Two input channels supply two input frequencies to the RFC 7 at a 1 : 1 ratio.: $\frac{f_1}{f_2} = \frac{1}{1}$
X to Y	Two input channels supply two input frequencies (e.g. a gas meter's main wheel and reference wheel) in an X-to-Y ratio: $\frac{f_1}{f_2} = \frac{X}{Y}$

Table 19: Coordinate 2.5.80 Volume transmitter mode – transfer types for the flow rate values

- ▶ At coordinate **2.5.90 Pulse source mode**, specify which signal inputs are to be used for volume conversion. The available options are:
 - PI1/PI2 (pulse input 1 (N1) / pulse input 2 (N2))
 - PI3/PI4 (digital input 1 (DI1) / digital input 2 (DI2))
- ▶ At coordinate **2.5.100 Kv factor mode (chapter 4)**, select the characteristic curve correction method. The available options are:
 - **Constant:** The characteristic curve of the flow rate measuring device is not corrected, i.e. it remains unchanged.
 - **Polynomial:** The characteristic curve of the flow rate measuring device is adjusted using a polynomial correction.

- **Interpolation point:** The characteristic curve of the flow rate measuring device is adjusted using an interpolation point correction.

NOTE**Note on characteristic curve correction methods**

The device-dependent percentage deviation from a constant flow rate characteristic curve is known through corresponding test measurements. Two different characteristic curve correction methods can be applied to correct this deviation:

- **Interpolation point correction** uses a defined number of interpolation points that the curve is corrected at. Linear approximation is used for correction between the interpolation points.
- **Polynomial correction** uses a typical polynomial curve to describe the deviation precisely and correct it accordingly. This method is generally more accurate than a simple interpolation point correction.

However, both methods have their merits, especially since the interpolation point correction within the measurement range (Q_{\min} – Q_{\max}) usually deviates by less than 0.1% from the polynomial correction. The polynomial correction generally gives better results in the flow rate range $< Q_{\min}$. The characteristic curve correction method should be chosen according to the operating conditions that occur most frequently. Both methods are approved under metrology legislation.



Detailed information on performing the characteristic curve correction can be found in section 8.7.2 "Characteristic curve".

- ▶ At coordinate **2.5.220**, enter the **Manufacturer** of the connected gas meter.
- ▶ At coordinate **2.5.230**, enter the **Device type** of the connected gas meter.
- ▶ At coordinate **2.5.240**, enter the **Serial number** of the connected gas meter.
- ▶ At coordinate **2.5.250**, enter the **Size** of the connected gas meter.

8.5.6 Flow rate at measured conditions – defining parameters

The parameters for the flow rate at measured conditions can sometimes only be defined when the calibration switch is unlocked.

Proceed as follows to define the parameters:

- Navigate to the menu page **2.6 Flow rate at measured conditions**.

Access	Coords	Name	Value	Unit	Details
✕	§ 2.6.10	Flow rate at measured conditions	0.00	m3/h	i
✕	§ 2.6.11	Freeze	0.00	m3/h	i
👤	2.6.20	Lower warning limit	0.00 PRESET	m3/h	i
👤	2.6.30	Upper warning limit	1000.00 PRESET	m3/h	i
✕	§ 2.6.50	Base value	0.00	m3/h	i
✕	§ 2.6.51	Base value freeze	0.00	m3/h	i
🔒	§ 2.6.60	Lower shut-off limit (Qml)	12.50 PRESET	m3/h	i
✕	2.6.70	Startup time	0	sek	i
✕	2.6.80	Rundown time	0	sek	i
🔒	§ 2.6.90	Max. startup time	86400 PRESET	sek	i
🔒	§ 2.6.100	Max. rundown time	86400 PRESET	sek	i
✕	2.6.40	Qm status	STATIONARY		i
✕	2.6.120	Minute average	0.00	m3/h	i
✕	2.6.130	hourly average	0.00	m3/h	i
✕	2.6.140	Ongoing revision average	0.00	m3/h	i
✕	2.6.150	Flow rate (M) revision average	0.00	m3/h	i

Fig. 67: Menu page 2.6 Flow rate at measured conditions

- At coordinate **2.6.20**, specify the **Lower warning limit** for the flow rate at measured conditions that a warning message (no alarm yet) is to be issued at.
- At coordinate **2.6.30**, specify the **Upper warning limit** for the flow rate at measured conditions that a warning message (no alarm yet) is to be issued at.
- At coordinate **2.6.60**, enter the **Low-flow cut-off limit**. The low-flow cut-off limit is the lowest flow rate that the connected flow rate measuring device can still measure reliably and accurately. All flow rates below the low-flow cut-off limit are automatically treated as **no** flow.
- At coordinate **2.6.90 Max. startup time**, specify the time interval during which the lower volume flow rate limits may be undercut, when the complete system is starting up, without triggering an alarm. Faultless startup is when the flow rate at measured conditions traverses the range from the low-flow cut-off to the lower alarm limit within the entered startup time. An alarm message is issued if the flow rate at measured conditions is still within the range between the low-flow cut-off and the lower alarm limit once the startup time has elapsed.
- At coordinate **2.6.100 Max. rundown time**, specify the time interval during which the lower volume flow rate limits may be undercut, when the complete system is shutting or ramping down, without triggering an alarm. Faultless rundown is when the flow rate at measured conditions traverses the range from the lower alarm limit to the low-flow cut-off within the entered rundown time. An alarm message is issued if the flow rate at measured conditions is still within the range between the lower alarm limit and the low-flow cut-off once the rundown time has elapsed.

8.5.7 Corrected flow rate at measured conditions – defining parameters

The corrected flow rate at measured conditions is calculated from the uncorrected flow rate at measured conditions and any characteristic curve correction.

Proceed as follows to define the corrected flow rate at measured conditions parameters:

- ▶ Navigate to the menu page **2.7 Corr. flow rate at measured conditions**.

Access	\$	Coords	Name	Value	Unit	Details
✕		2.7.10	Corr. flow rate at measured conditions	0.00	m3/h	<i>i</i>
✕		2.7.11	Freeze	0.00	m3/h	<i>i</i>
<i>i</i>		2.7.20	Lower warning limit	0.00	m3/h	<i>i</i>
<i>i</i>		2.7.30	Upper warning limit	1000.00	m3/h	<i>i</i>
✕		2.7.50	Minute average	0.00	m3/h	<i>i</i>
✕		2.7.60	Hourly average	0.00	m3/h	<i>i</i>
✕		2.7.70	Ongoing revision average	0.00	m3/h	<i>i</i>
✕		2.7.80	Corr. flow rate (M) revision average	0.00	m3/h	<i>i</i>
✕		2.7.90	Min. drag indicator	0.00	m3/h	<i>i</i>
✕		2.7.100	Max. drag indicator	0.00	m3/h	<i>i</i>
✕		2.7.110	Min. drag indicator timestamp	2026-05-12T07:31:18		<i>i</i>
✕		2.7.120	Max. drag indicator timestamp	1970-01-01T01:00:00		<i>i</i>

Fig. 68: Menu page 2.7 Corrected flow rate at measured conditions

- ▶ At coordinate **2.7.20**, specify the **Lower warning limit** for the corrected flow rate at measured conditions that a warning message (no alarm yet) is to be issued at.
- ▶ At coordinate **2.7.30**, specify the **Upper warning limit** for the corrected flow rate at measured conditions that a warning message (no alarm yet) is to be issued at.

8.5.8 Compressibility factor calculation – defining parameters

The parameters for the compressibility factor calculation can only be defined when the calibration switch is unlocked.

Proceed as follows to define the parameters:

- ▶ Navigate to the menu page **2.8 K coefficient**.

Access	Coords	Name	Value	Unit	Details
✕ §	2.8.10	Conversion factor	44.0128		i
✕ §	2.8.11	Conversion factor freeze	0.0000		i
✕ §	2.8.20	K coefficient	0.90853		i
✕ §	2.8.21	K coefficient freeze	0.00000		i
✕ §	2.8.30	Compressibility factor (M)	0.90618		i
✕ §	2.8.31	Compressibility factor (M) freeze	0.00000		i
✕ §	2.8.40	Compressibility factor (B)	0.99741		i
✕ §	2.8.41	Compressibility factor (B) freeze	0.00000		i
🔒 §	2.8.50	Type of Equation of state (EoS)	Complete analysis		i
🔒 §	2.8.60	EoS with complete analysis	AGA8-DC92		i
🔒 §	2.8.110	Pressure at base conditions mode	1.01325 bar		i
🔒 §	2.8.120	Temperature at base conditions mode	0°C		i
🔒 §	2.8.130	Combustion temperature mode	25°C		i
🔒 §	2.8.140	Rankine factor AGA NX-19	492°R		i
🔒 §	2.8.160	GQ limit monitoring mode	Pipeline-quality gas		i
🔒 §	2.8.170	neo-pentane surcharge	n-pentane		i

Fig. 69: Menu page 2.8 K coefficient

- ▶ At the dropdown menu of coordinate **2.8.50**, specify the **Type of equation of state** and save your selection. The following are available:
 - **Complete analysis:** All components of the measured gas are used in the calculation. The values are obtained from a gas chromatograph, for example, or processed as default values in the Flow Computer.
 - **Gross values:** Only individual values of the measured gas are used in the calculation.
 - **Pure substance:** The measured gas is a pure industrial gas, e.g. oxygen, nitrogen, argon, helium.
 - **Simple:** The measured gas is an ideal gas or the same measured gas, with a known and constant compressibility factor, is always used.

Depending on the saved selection described above, the following coordinates with the associated dropdown menus are shown or hidden:

- **2.8.60 Equation of state with complete analysis**
- **2.8.90 Equation of state with gross values**
- **2.8.80 Equation of state for pure substance**
- **2.8.70 Equations of state Simple**

The tables below show the various selection options:

2.8.60 Equations of state with complete analysis	
Selectable equation of state	Explanation
AGA8:2017	AGA 8:2017 is a standard published by the American Gas Association (AGA) that defines an equation of state for calculating the thermodynamic properties of natural gases. This equation enables the precise determination of properties such as density and compressibility factor for natural gas mixtures that may consist of up to 21 different components.

Table 20: Selection options for 2.8.90 Equation of state with complete analysis

2.8.60 Equations of state with complete analysis	
Selectable equation of state	Explanation
AGA8-DC92	The AGA 8 DC92 method is used to calculate the compressibility factor of 'normal' natural gas. It is the most recent accepted and approved gas model description (as of 2017) and is therefore often used as a gas model.
GERG-2004	GERG-2004 is a wide-ranging equation of state developed by the European Gas Research Group (GERG). It is used to calculate the thermodynamic properties of natural gases and other mixtures. 17 gas components are used for precise calculations.
GERG-2008	GERG-2008 is an extension of GERG-2004. It includes four additional gas components. It also offers higher accuracy and has an extended range of application in terms of temperatures and pressures. It delivers more precise results for the thermodynamic properties of natural gases and other mixtures.

Table 20: Selection options for 2.8.90 Equation of state with complete analysis

2.8.90 Equation of state with gross values	
Selectable equation of state	Explanation
AGA8 GM1	AGA 8 Gross Method 1 is used in North America. The equation is used when the following values for the gas to be measured are known: <ul style="list-style-type: none"> ■ Calorific value (Ho) ■ Standard density (ρn) ■ Carbon dioxide content (CO₂) ■ Hydrogen content (H₂)
AGA8 GM2	AGA 8 Gross Method 2 is used in North America. The equation is used when the following values for the gas to be measured are known: <ul style="list-style-type: none"> ■ Standard density (ρn) ■ Carbon dioxide content (CO₂) ■ Hydrogen content (H₂) ■ Nitrogen content (N₂)
AGA8 GM3	AGA 8 Gross Method 3 is used in North America. The equation is used when the complete composition of the gas to be measured is known.
SGERG-88	GERG 88 S is used in Europe. The equation is used when the following values for the gas to be measured are known: <ul style="list-style-type: none"> ■ Calorific value (Ho) ■ Standard density (ρn) ■ Carbon dioxide content (CO₂) ■ Hydrogen content (H₂)
GERG B	GERG 88 S Set B is used in Europe. The equation is used when the following values for the gas to be measured are known: <ul style="list-style-type: none"> ■ Calorific value (Ho) ■ Standard density (ρn) ■ Hydrogen content (H₂) ■ Nitrogen content (N₂)

Table 21: Selection options for 2.8.90 Equation of state with gross values

2.8.90 Equation of state with gross values	
Selectable equation of state	Explanation
GERG C	<p>GERG 88 S Set C is used in Europe. The equation is used when the following values for the gas to be measured are known:</p> <ul style="list-style-type: none"> ■ Standard density (ρ_n) ■ Carbon dioxide content (CO_2) ■ Hydrogen content (H_2) ■ Nitrogen content (N_2)
GERG-mod-H2	<p>GERG-mod-H2 is a modified equation of state based on SGERG-88 and developed specifically for calculating the thermodynamic properties of natural gases with higher hydrogen contents. This equation enables precise calculations of compressibility factors and gas law deviation factors for natural gas / hydrogen mixtures, which is especially important for integrating hydrogen into existing natural gas infrastructures.</p>
AGA NX-19L	<p>AGA NX-19L is a revision of AGA 8 specifically for L-gas (natural gas with a low energy content).</p>
AGA NX-19H	<p>AGA NX-19H is a revision of AGA 8 specifically for H-gas (natural gas with a high energy content).</p>

Table 21: Selection options for 2.8.90 Equation of state with gross values

2.8.80 Equation of state with pure substance	
Selectable equation of state	Explanation
Van der Waals	<p>The Van der Waals equation of state is a mathematical equation describing the behaviour of real gases and extending the ideal gas equation. It enables better approximation of the behaviour of real gases, especially at high pressures and low temperatures, where the ideal gas equation becomes inaccurate.</p>
Beattie & Bridgeman	<p>The Beattie & Bridgeman equation of state is also a mathematical equation describing the behaviour of real gases and extending the ideal gas equation. It is, however, more complex than the Van der Waals equation, since it introduces additional empirical constants to improve accuracy.</p>

Table 22: Selection options for 2.8.90 Equation of state with pure substance

2.8.70 Equation of state Simple	
Equation of state	Explanation
Constant	<p>If the same measured gas is always used and its compressibility factor is known, the Constant selection can be used. A constant default value is then used for the compressibility factor.</p> <ul style="list-style-type: none"> ▶ At coordinate 2.8.100 Compressibility factor default value, enter the value for the compressibility factor and confirm your entry by saving.

Table 23: Selection options for 2.8.90 Equations of state Simple

- ▶ At the dropdown menu of coordinate **2.8.60/.70/.80/.90**, specify the required **equation of state** for calculating the compressibility factor.

- ▶ At the dropdown menu of coordinate **2.8.110 Pressure at base conditions mode**, specify which pressure is to be used for the calculation. The available options are:
 - 1,01325 bar (valid in Germany)
 - 1 bar
 - 14.73 psi
 - 14.696 psi
 - 14.503 psi
- ▶ At the dropdown menu of coordinate **2.8.120**, specify the **Temperature at base conditions mode** to be used for the calculation. The available options are:
 - 0 °C (valid in Germany)
 - 15 °C
 - 20 °C
 - 59 °F
 - 60 °F
- ▶ At the dropdown menu of coordinate **2.8.130**, specify the **Combustion temperature mode** to be used for the calculation. The available options are:
 - 0 °C
 - 15 °C
 - 20 °C
 - 25 °C (valid in Germany)
 - 60 °F
- ▶ At the dropdown menu of coordinate **2.8.140**, select the **Rankine factor** to be used for the **AGA NX-19** equation of state. The available options are:
 - 492 °R
 - 491.67 °R
- ▶ At the dropdown menu of coordinate **2.8.160 GQ limit monitoring mode**, specify whether limit monitoring of the gas quality is to be carried out in accordance with the standard when the SGERG-88, GERGmodH2 or AGA8-DC92 equation of state is used. The following limit options are available:
 - **No limits:** No limit value monitoring takes place, as the measured gas with its components may be outside the range in which it is possible to make a quality statement.
 - **Pipeline-quality gas:** The associated limit values are established in the standard ISO 13686:2013 and are applied to dried, cleaned natural gas. This setting must be selected for use in fiscal applications.
 - **Wider ranges of app:** The associated limit values are established in the standard ISO 12213-1:2006 and are applied to biogases. This setting can also be selected for extended temperature and pressure ranges, but with increased uncertainty.

8.5.9 Flow rate at base conditions – defining parameters

The flow rate at base conditions is calculated from the corrected flow rate at measured conditions and a pressure and temperature correction, taking the real gas factor into account.

Proceed as follows to define the flow rate at base conditions parameters:

- ▶ Navigate to the menu page **2.9 Flow rate at base conditions**.

RMG 1 RFC 71
RFC 7 Bdh
2026-05-12 09:31:12

2. Conversion -> 9 Flow rate at base conditions
EN

Text search

- 1. Overviews
- 2. Conversion
- 2.1 Units
- 2.2 Formats
- 2.3 Gas pressure
- 2.4 Gas temperature
- 2.5 Flow rate parameters
- 2.6 Flow rate at measured conditions
- 2.7 Corr. flow rate at measured conditions
- 2.8 K coefficient
- 2.9 Flow rate at base conditions
- 2.10 Energy flow
- 2.17 Counter mode
- 2.100 Counters - billing mode 1
- 2.200 Fault counters - billing mode 1
- 2.300 Counters - billing mode 2
- 2.400 Fault counters - billing mode 2

Access	S	Coords	Name	Value	Unit	Details
✕		2.9.10	Flow rate at base conditions	0.00	m3/h	i
✕		2.9.11	Freeze	0.00	m3/h	i
		2.9.20	Lower warning limit	0.00	m3/h	i
		2.9.30	Upper warning limit	87500.00	m3/h	i
✕		2.9.50	Minute average	0.00	m3/h	i
✕		2.9.60	hourly average	0.00	m3/h	i
✕		2.9.70	Ongoing revision average	0.00	m3/h	i
✕		2.9.80	Flow rate (B) revision average	0.00	m3/h	i
✕		2.9.90	Min. drag indicator	0.00	m3/h	i
✕		2.9.100	Max. drag indicator	0.00	m3/h	i
✕		2.9.110	Min. drag indicator timestamp	2026-05-12T07:31:18		i
✕		2.9.120	Max. drag indicator timestamp	1970-01-01T01:00:00		i

Fig. 70: Menu page 2.9 Flow rate at base conditions

- ▶ At coordinate **2.9.20**, specify the **Lower warning limit** for the flow rate at base conditions that a warning message (no alarm yet) is to be issued at.
- ▶ At coordinate **2.9.30**, specify the **Upper warning limit** for the flow rate at base conditions that a warning message (no alarm yet) is to be issued at.

8.5.10 Energy flow – defining parameters

The energy flow is calculated from the flow rate at base conditions and the energy content of the measured gas. The energy content is determined from the gas composition and the equation of state applied.

Proceed as follows to define the energy flow parameters:

- Navigate to the menu page **2.10 Energy flow**.

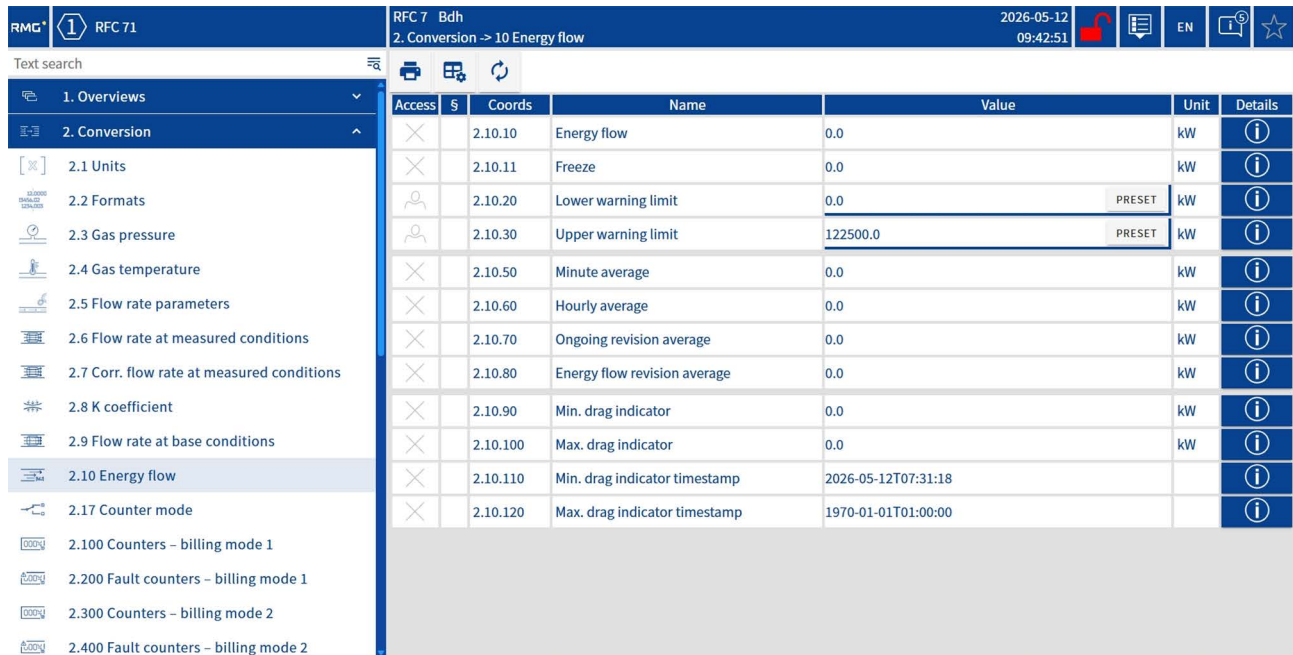

Fig. 71: Menu page 2.10 Energy flow

- At coordinate **2.10.20**, specify the **Lower warning limit** for the energy flow that a warning message (no alarm yet) is to be issued at.
- At coordinate **2.10.30**, specify the **Upper warning limit** for the energy flow that a warning message (no alarm yet) is to be issued at.

8.5.11 Counter mode – defining parameters

The RFC 7 generally has two counter sets, which can perform different tasks such as:

- Using a meter in forward and reverse operation:
 - Filling and emptying a gas storage facility.
 - When switching between lines at different pressures, temporary reverse flows can occur and need to be recorded separately.
- Determining the flow rate in different lines:
 - Using two lines with different cross-sections and corresponding gas meters for winter and summer operation.
 - Gas from two different sources is fed into the downstream network.

Proceed as follows to define the counter mode parameters:

- Navigate to the menu page **2.17 Counter mode**.

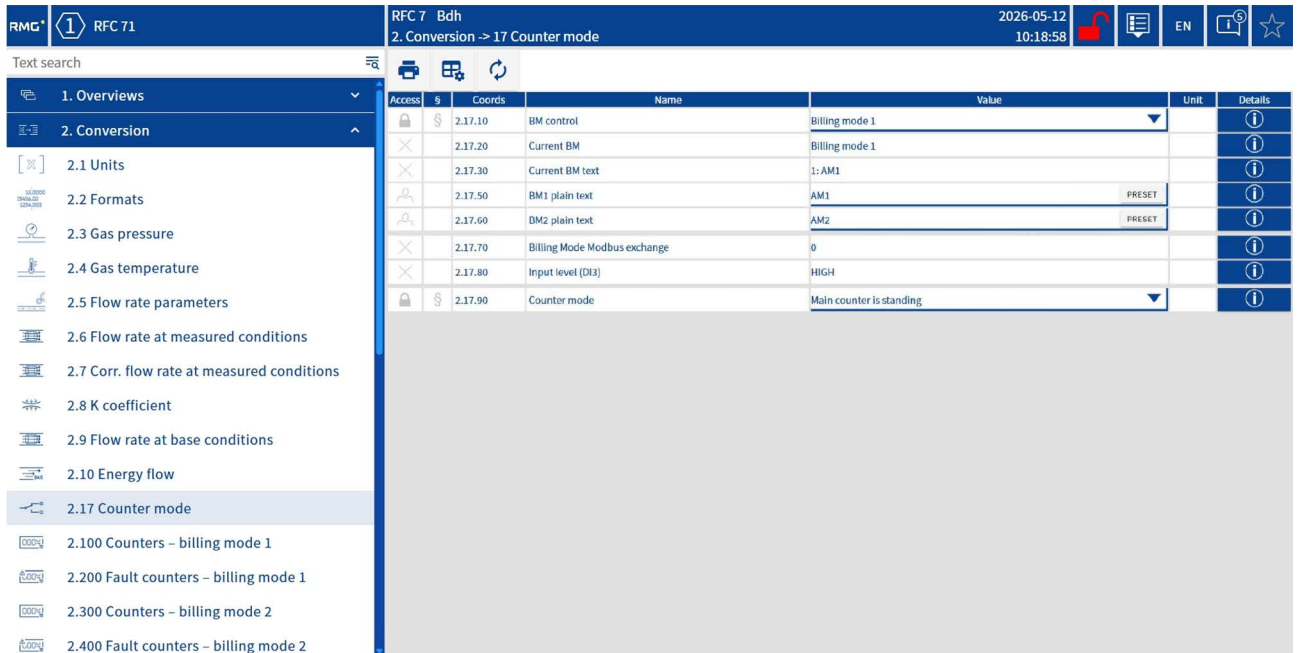

Fig. 72: Menu page 2.17 Counter mode

NOTE

Abbreviation – BM

The abbreviation BM stands for ‘billing mode’.

- ▶ At coordinate **2.17.10 BM control**, specify how the billing mode is to be activated according to your application. The available options are:
 - Billing mode 1
 - Billing mode 2
 - Undefined billing mode
 - Modbus
 - DI3=HIGH switches to BM1, DI3=LOW switches to BM2
 - Instance F direction
- ▶ Name billing modes 1 and 2 at coordinates **2.17.50 BM1 plain text** and **2.17.60 BM2 plain text** according to your application (e.g. winter operation / summer operation, etc.).
- ▶ At coordinate **2.17.90**, specify the **Counter mode**. The available options are:
 - **Main counter is standing:** If a fault occurs, the main counter halts and the measured data is recorded in the fault counter.
 - **Main counter is running:** If a fault occurs, the main counter continues to run and the measured data is additionally recorded in the fault counter.
 - **Main counter under the MID:** If a fault that does not affect the determination of the measured volume (e.g. a temperature sensor fails) occurs, the measured volume continues to be recorded in the main counter. Meanwhile, the volume at base conditions and the variables that depend on it (energy) are recorded in the fault counter.
If the fault present also affects the determination of the measured volume, the main counter halts and the measured data is recorded in the fault counter, in the same way as in the ‘Main counter is standing’ mode.

8.6 Gas quality (GQ) – defining parameters

The values for the gas quality are usually determined by a connected gas analyser and transferred to the Flow Computer.

8.6.1 GQ setting

Proceed as follows to configure the transfer of the gas quality values:

- Navigate to the menu page **3.10 GQ setting**.

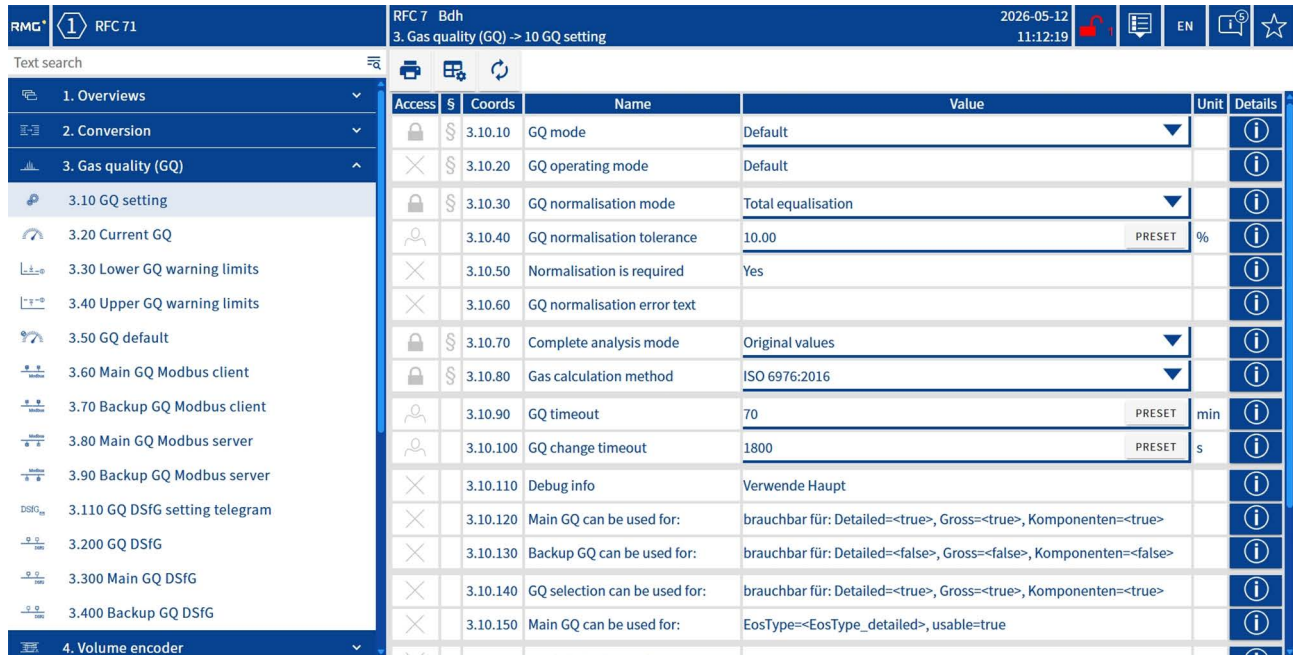

Fig. 73: Menu page 3.10 GQ setting

- At the dropdown menu of coordinate **3.10.10**, specify the **GQ mode** for transferring the gas quality values. The available options are:
 - Default value (entered default values are used)
 - DSfG setting telegram
 - DSfG-A
 - Modbus client
 - Modbus server
 - DSfG-A redundancy
 - Modbus client redundancy
 - Modbus server redundancy

The setting options change depending on the mode selected.

NOTE

New Modbus terminology: client instead of master, server instead of slave

On the recommendation of the Modbus Organisation, the terms ‘Modbus master’ and ‘Modbus slave’ are being replaced by ‘Modbus client’ and ‘Modbus server’ for the RFC 7 and all other devices on the RMG platform to promote more inclusive and modern language. The main reasons for this change are:

- **Avoidance of discriminatory language:** Use of the terms ‘client’ and ‘server’ promotes more respectful communication.
- **Clear description of functionality:** The client initiates requests and the server responds to them, which better matches the actual processes in the Modbus protocol.
- **Consistency with other protocols:** Many modern communication protocols already use the terms ‘client’ and ‘server’. Adapting the terminology in Modbus makes it easier to understand and integrate into existing systems.

If the data transmitted by the gas analyser is required for multiple gas models, e.g. at a gas transfer station on a national border, different reference conditions may have been used as the basis for the calculation in the gas analyser. Depending on the further application, it may then be necessary to recalculate the gas quality values determined in the gas analyser, such as calorific value, standard density, etc.

- ▶ At coordinate **3.10.70 Complete analysis mode**, specify which values are to be used for further processing in the RFC 7. The following options are available for selection:
 - **Original values:** The values determined in the gas analyser are used.
 - ➔ The **original values** are shown in the menu **3.20 GQ (current)**.
 - **Calculated values:** The values calculated in the RFC 7 are used. The adjustment options described below are taken into account.
 - ➔ The **calculated values** are shown in the menu **3.20 GQ (current)**.

Proceed as follows to configure the methods for recalculating the values:

- ▶ At coordinate **3.10.80 Gas calculation method**, specify the version of the standard to be used. The following are available:
 - ISO 6976:2005
 - ISO 6976:2016

The difference between the two versions lies in minimal (rounding) deviations in the calculation.

NOTE

Activating use of ISO 6976

The use of DIN EN ISO 6976:2005 or DIN EN ISO 6976:2016 can only be activated when the gas quality determination model uses a full gas composition analysis.

- ▶ Check whether complete analysis is selected at coordinate **2.8.50 Type of Equation of state** in the menu **2.8 K coefficient**.

Depending on the application, it may be necessary to normalise the total of all gas fractions to 100%. Proceed as follows to do this:

- ▶ At the dropdown menu of coordinate **3.10.30 GQ normalisation mode**, specify the desired method. The following are available:

- **Off:** Normalisation is not performed. (Recommended for determining the compressibility factor with the ‘Gross values’ equation of state type at coordinate 2.8.50)
- **Total equalisation:** The fractions of the individual gas components are divided by the total of all unnormalised gas fractions and multiplied by 100.
- **Methane equalisation:** The fractions of the individual gas components are subtracted from 100%. The remainder represents the methane fraction.
- ▶ At coordinate **3.10.40 GQ normalisation tolerance**, specify the permitted percentage deviation of the total of all gas fractions from 100% before normalisation.

The following possible errors in the gas quality determined by the gas analyser may lead to errors during normalisation:

- A gas component is negative.
- The sum of the gas components is ≤ 0 .
- The sum of the gas components before normalisation deviates from 100% by more than the entered tolerance (coordinate 3.10.40).
- ▶ At coordinate **3.10.90 GQ timeout**, specify a time interval after which an alarm is triggered if the gas analyser receives no new gas data in the meantime.
- ▶ If the **Modbus client redundancy**, **Modbus server redundancy** or **DSfG-A redundancy** mode is selected at coordinate **3.10.10 GQ mode**, you must set a fault time at coordinate **3.10.100 GQ changeover timeout**, after which the operating mode automatically changes from the **main** Modbus client / server to the **backup** Modbus client / server, or from the **main** DSfG to the **backup** DSfG. The changeover only takes place, however, if a **main** measurement has not been received within this period.
Automatic change-back to the **main** Modbus client / server or to the **main** DSfG does not take place until either an error is present in the **backup** Modbus client / server or the **backup** DSfG operating mode, or no data has been received during the error time. At the same time, current, valid data must be present on the relevant main channel for the change-back to take place.

8.6.2 GQ lower and upper warning limits

Proceed as follows to set the parameters for the warning limits of the individual gas components:

- ▶ To enter the lower warning limits, navigate to the menu page **3.30 GQ lower warning limits**.
- ▶ To enter the upper warning limits, navigate to the menu page **3.40 GQ upper warning limits**.

Access	Coords	Name	Value	Unit	Details
	3.30.10	Calorific value	7,000	kWh/m3	
	3.30.20	Standard density	0,7000	kg/m3	
	3.30.40	Carbon dioxide	0,000	mol %	
	3.30.50	Hydrogen	0,000	mol %	
	3.30.60	Nitrogen	0,000	mol %	
	3.30.70	Methane	70,000	mol %	
	3.30.80	Ethane	0,000	mol %	
	3.30.90	Propane	0,000	mol %	
	3.30.100	n-butane	0,000	mol %	
	3.30.110	i-butane	0,000	mol %	
	3.30.120	n-pentane	0,000	mol %	
	3.30.130	i-pentane	0,000	mol %	
	3.30.140	neo-pentane	0,000	mol %	
	3.30.150	Hexane	0,000	mol %	
	3.30.160	Heptane	0,000	mol %	
	3.30.170	Octane	0,000	mol %	
	3.30.180	Nonane	0,000	mol %	
	3.30.190	Decane	0,000	mol %	
	3.30.200	Hydrogen sulphide	0,000	mol %	

Fig. 74: Menu page 3.30 GQ lower warning limits (example)

Entry of the lower warning limits is described below as an example. The upper warning limits can be entered in the same way at the corresponding menu page **3.40 GQ upper warning limits**.

- ▶ At coordinate **3.30.10 Calorific value**, enter the value for the lower warning limit either manually using the keyboard or by clicking on the Default button.
- ▶ At coordinate **3.30.20 Standard density**, enter the value for the lower warning limit.
- ▶ At coordinates **3.30.40 to 3.30.270**, enter the lower warning limits for the molar fractions of the individual gas components (such as carbon dioxide, hydrogen, nitrogen, methane, ethane, etc.).

NOTE

Selecting the equation of state in menu 2. 8 K coefficient

The gas components listed here depend on the equation of state type selected at coordinate 2.8.50. Only when a complete analysis is selected there will all the gas components be shown for defining the warning limits.

8.6.3 GQ default values

Entry of default values for the gas quality is necessary to enable volume conversion to continue if the measured value transmission fails.

- ▶ Please therefore enter the values for the gas you are measuring.
- ▶ If you are using a bus connection to transfer the gas values, read out the actual values once and then enter them as default values.
- ▶ Please check the values regularly and adjust them if necessary.

Proceed as follows to enter the default values:

- ▶ Navigate to the menu page **3.50 GQ default**.

Access	Coords	Name	Value	Unit	Details
	3.50.10	Calorific value	11,294	PRESET kWh/m3	
	3.50.20	Heating value	10,000	PRESET kWh/m3	
	3.50.30	Standard density	0,7511	PRESET kg/m3	
	3.50.50	CO2 emission factor	57,0000	PRESET t CO2/TJ	
	3.50.60	Component sum (unnormalised)	100,000	mol %	
	3.50.70	Carbon dioxide	0,600	PRESET mol %	
	3.50.80	Hydrogen	0,000	PRESET mol %	
	3.50.90	Nitrogen	0,300	PRESET mol %	
	3.50.100	Methane	96,500	PRESET mol %	
	3.50.110	Ethane	1,800	PRESET mol %	
	3.50.120	Propane	0,450	PRESET mol %	
	3.50.130	n-butane	0,100	PRESET mol %	
	3.50.140	i-butane	0,100	PRESET mol %	
	3.50.150	n-pentane	0,030	PRESET mol %	
	3.50.160	i-pentane	0,050	PRESET mol %	
	3.50.170	neo-pentane	0,000	PRESET mol %	
	3.50.180	Hexane	0,070	PRESET mol %	
	3.50.190	Heptane	0,000	PRESET mol %	
	3.50.200	Octane	0,000	PRESET mol %	

Fig. 75: Menu page 3.50 GQ default

- ▶ At coordinate **3.50.10 Calorific value**, enter a default value for the calorific value of the gas you are measuring manually using the keyboard. Clicking on the Default button enters the standard value stored in the device as the default value.
- ▶ At coordinate **3.50.30 Standard density**, enter a default value for the standard density of the gas you are measuring manually using the keyboard. Clicking on the Default button enters the standard value stored in the device as the default value.
- ▶ At coordinates **3.50.60 to 3.50.290**, enter the molar fractions of the individual gas components (such as carbon dioxide, hydrogen, nitrogen, methane, ethane, etc.).

NOTE

Using default values if an error occurs

If an error occurs in the gas quality measurement, the default values are referred to as 'error fallback data' and are used.

8.6.4 Main GQ Modbus client

Proceed as follows to configure the Modbus connection settings and define the Modbus addresses for the gas components:

- Navigate to the menu page **3.60 Main GQ Modbus client**.

Access	Coords	Name	Value	Unit	Details
	3.60.10	Mode	Off		
	3.60.20	Debug info	Off		
	3.60.30	Byte order	Big 1234		
	3.60.40	Register offset	0		
	3.60.50	Address offset	1		
	3.60.60	Modbus ID	1		
	3.60.70	Server accepts gaps	No		
	3.60.80	Max. gap size	20		
	3.60.90	Read function code	Function code 3		
	3.60.110	IP4 address			
	3.60.120	TCP port	502		
	3.60.130	Modbus cycle delay	0,5	s	
	3.60.140	Trigger type	Counter		
	3.60.150	Modbus client GQ main default setting	SELECT PREALLOCATION		
	3.60.160	Type of Equation of state	Complete analysis		
	3.60.170	Trigger register value	0		
	3.60.171	Trigger register value formula	0		
	3.60.172	Complete trigger register value formula			
	3.60.173	Trigger register value formula status			

Fig. 76: Menu page 3.60 Main GQ Modbus client

- At coordinate **3.60.10 Mode**, specify which interface data is to be exchanged over. The following are available:
 - Off
 - Ser 1
 - Ser 2
 - Ser 3
 - IP
- At coordinate **3.60.20**, activate the **debug info** data:
 - Off
 - On
- At coordinate **3.60.30**, specify the **byte order**. The following are available:
 - Big 1234
 - Little 4321
 - LittleBig 2143
 - BigLittle 3412
- At coordinate **3.60.40**, enter the **register offset** and, at coordinate **3.60.50**, enter the **address offset**. Both coordinates can only accept the value '0' or '1'.

NOTE**Relationship between Modbus, register offset and address offset**

Modbus distinguishes between registers and register addresses, where a register address is always '1' lower than the corresponding register.

Example:

- If the registers were numbered 1 to 16, the corresponding register addresses would be numbered 0 to 15.

On this menu page (3.60 Main Modbus client), the registers for the values to be transferred are entered from coordinate **3.60.301** onwards. Since Modbus always sends register addresses, the Modbus library internally and automatically subtracts the value '1' from the entered register before sending the request.

The **address offset** at coordinate **3.60.50** now serves to reverse this automatic process by adding the value '1' back on.

In addition to the address offset, there is a **register offset** at coordinate **3.60.40**, since some devices send and receive their addresses with an offset. With the **register offset**, the value '1' can additionally be added as an option so that the system can communicate with as many devices as possible.

The only difference between the address offset and the register offset is the name. Both perform the same function: adding the value '1' to the entered register (from coordinate 3.60.301).

Below are a few examples for illustrative purposes:

1. Entered value at coordinate 3.60.301 = F(7000)
Selected register offset = 0
Selected address offset = 0
➔ The register address 6999 is sent.
2. Entered value at coordinate 3.60.301 = F(7000)
Selected register offset = 0
Selected address offset = 1
➔ The register address 7000 is sent.
3. Entered value at coordinate 3.60.301 = F(7000)
Selected register offset = 1
Selected address offset = 0
➔ The register address 7000 is sent.
4. Entered value at coordinate 3.60.301 = F(7000)
Selected register offset = 1
Selected address offset = 1
➔ The register address 7001 is sent.

-
- ▶ At coordinate **3.60.60**, enter the **Modbus ID**.
 - ▶ At coordinate **3.60.70 Server accepts gaps**, specify whether the server is able to process incomplete or fragmented requests:
 - No
 - Yes
 - ▶ At coordinate **3.60.80**, enter the **maximum** size of these gaps or **holes**.

- ▶ Define the request at coordinate **3.60.90 Read function code**. The available options are:
 - Function code 3
 - Function code 4
- ▶ If you have selected the IP mode at coordinate 3.60.10, enter the **IP4 address** at coordinate **3.60.110**.
- ▶ At coordinate **3.60.120**, enter the corresponding **TCP port**.
- ▶ Specify the **Modbus cycle delay** at coordinate **3.60.130**. The Modbus cycle delay is the time interval that occurs between communication cycles in a Modbus network. It is influenced by various factors, such as the devices' processing speed, the network latency and how the Modbus client is configured.
- ▶ Select the **trigger type** at coordinate **3.60.140** to initiate the retrieval of the gas quality measurement data. The following are available:
 - Off
 - Counter (the 'Counter' trigger type uses a counter maintained by the gas quality measurement (PGC). The PGC increments the counter after each measurement. The RFC 7 checks this value regularly at intervals of the **Modbus cycle delay** (coordinate **3.60.130**). As soon as the counter value has changed and coordinate **3.60.180 Relevant actual analysis (boolean)** shows the value '1' (= a valid PGC stream is active), retrieval of the new measurement data is triggered by the RFC 7.)
 - Flag Timer (the 'Flag Timer' trigger type is also maintained by the gas quality measurement. The difference from Counter is that the flag can only accept the value '0' or '1' and is not incremented. As soon as a new measurement is available, the PGC sets the flag to '1'. The RFC 7 checks this value regularly at intervals of the **Modbus cycle delay** (coordinate **3.60.130**). When the RFC 7 detects the flag's '1' value and coordinate **3.60.180 Relevant actual analysis (boolean)** also shows the value '1' (= a valid PGC stream is active), retrieval of the new measurement data is triggered by the RFC 7. The PGC resets the flag to '0' after a **defined time**, hence the name 'Flag Timer'.)
 - Set Flag (with the 'Set Flag' trigger type, the flag is set in the same way as with the 'Flag Timer' trigger type). However, resetting to '0' is handled by the RFC 7 after the measurement data has been retrieved. The 'Set Flag' trigger type is only used in rare cases. The following must be observed in this regard in particular: A specific flag must be used for each stream, or every stream of the PGC must be read out and the flag must be reset accordingly. The selection of which PGC streams are read out is made at coordinate **3.60.181 Relevant actual analysis formula**. The corresponding registers can be entered here.

NOTE

Note on the ‘Set Flag’ trigger type

If the setting at coordinate **3.60.181 Relevant actual analysis formula** has not been made correctly, the following situation may occur:

1. The RFC 7 waits exclusively for measurements from the PGC’s stream 1 (set accordingly at coordinate 3.60.181).
2. The PGC receives the new measurement for stream 1 and sets the flag to ‘1’.
3. The RFC 7 retrieves the measurement and resets the flag to ‘0’.
 - ➔ Everything is OK.
4. The PGC receives a new measurement for stream 2 and sets the flag to ‘1’.
5. The RFC 7 ignores the measurement, as it is configured for stream 1 only (coordinate 3.60.181).
 - ➔ The flag is not reset to ‘0’.
6. The PGC receives a new measurement for stream 1, but the flag is still set to ‘1’.
 - ➔ The RFC 7 does not retrieve the measurement, since the flag was never reset, and consequently no further measurements are retrieved.

Since the gas analysers PGC 930x and RGC 7 from RMG can serve up to four different measuring points (known as streams) in one measurement cycle, up to four different gas compositions must be processed.

For this purpose, various default settings can be selected at the dropdown menu of coordinate 3.60.150 Modbus client GQ main default setting (see fig. 77), so that the corresponding preset Modbus registers are entered for each gas component.

Proceed as follows to do this:

- ▶ Open the dropdown menu of coordinate **3.60.150 Modbus client GQ main default setting**.

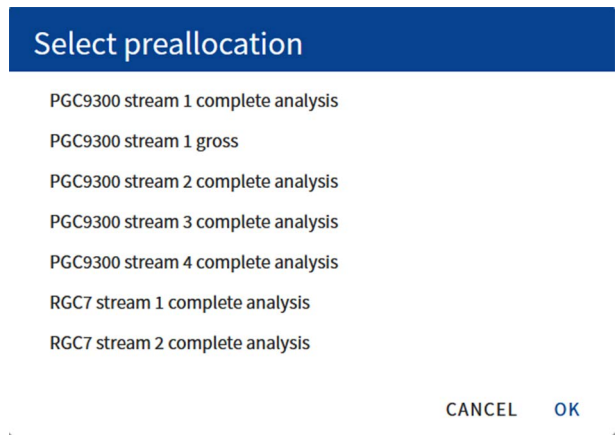

Fig. 77: Dropdown menu of coordinate 3.60.150

- ▶ Select the required stream and confirm your selection by clicking on the **OK** button.
 - ➔ The Modbus registers are entered for each gas component; see fig. 78. All fields with changed values are highlighted with a light blue background.

Access	Coords	Name	Value	Unit	Details
✕	3.60.300	Calorific value	0.000	kWh/m3	ⓘ
👤	3.60.301	Calorific value formula	F(7000) PRESET		ⓘ
✕	3.60.302	Calorific value complete formula			ⓘ
✕	3.60.303	Calorific value formula status			ⓘ
✕	3.60.310	Standard density	0.0000	kg/m3	ⓘ
👤	3.60.311	Standard density formula	F(7004) PRESET		ⓘ
✕	3.60.312	Standard density complete formula			ⓘ
✕	3.60.313	Standard density formula status			ⓘ
✕	3.60.320	Carbon dioxide	0.000	mol %	ⓘ
👤	3.60.321	Carbon dioxide formula	F(8004) PRESET		ⓘ
✕	3.60.322	Carbon dioxide complete formula			ⓘ
✕	3.60.323	Carbon dioxide formula status			ⓘ
✕	3.60.330	Hydrogen	0.000	mol %	ⓘ
👤	3.60.331	Hydrogen formula	F(8034) PRESET		ⓘ
✕	3.60.332	Hydrogen complete formula			ⓘ
✕	3.60.333	Hydrogen formula status			ⓘ
✕	3.60.340	Nitrogen	0.000	mol %	ⓘ
👤	3.60.341	Nitrogen formula	F(8000) PRESET		ⓘ
✕	3.60.342	Nitrogen complete formula			ⓘ

Fig. 78: Menu page 3.60 Main GQ Modbus client – entered Modbus registers

NOTE

Checking the Modbus addresses

Incorrect entry of Modbus addresses can lead to nonsensical calculation values.

- ▶ Carefully check the individual gas components’ addresses on your gas analyser to ensure that they match the Modbus addresses entered in the flow computer, taking the offsets (register and address) for both devices into account.
- ▶ Once the Modbus-specific settings have been made, please do not change them again, as otherwise correct acceptance of the gas values from the gas analyser can no longer be guaranteed.

Regardless of the lists of default settings, further settings can be made or mathematical calculations can be programmed in the input fields of the individual gas components containing the term ‘formula’ in the coordinate name. The programming options are listed below.

Available data types:

Entry	Description	Example
U16(1000)	16-bit unsigned integer	61440
I16(1000)	16-bit signed integer	-4096
U32(3000)	32-bit unsigned integer	4026531840
I32(3000)	32-bit signed integer	-268435456
U64(9000)	64-bit unsigned integer	17293822569102705000
I64(9000)	64-bit signed integer	-1152921504606846976
F(7000)	32-bit floating point number (float)	1234.567
D(9004)	64-bit floating point number (double)	1234567890.123456

Table 24: Available data types

The number inside the brackets (e.g. U16(1000)) is the associated register number.

Mathematical and logical operations

Symbol	Description	Sample calculation	Entry
0	Set line to 0		
1	Set line to 1		
+	Addition	3+2 = 5.0	U16(3000)+U16(3002)
-	Subtraction	3-2 = 1.0	U32(5000)-U16(3002)
*	Multiplication	3*2 = 6.0	U16(3000)*I32(5002)
/	Division	3/2 = 1.5	U16(3000)/I32(5002)
<	Less than	3<2 = 0 2<3 = 1	U16(3000)<I32(5002)
>	Greater than	3>2 = 1 2>3 = 0	U16(3000)>I32(5002)
==	Equal to	3==2 = 0 3==3 = 1	U16(3000)==I32(5002)
<=	Less than or equal to	3<=2 = 0 2<=2 = 1	U16(3000)<=I32(5002)
>=	Greater than or equal to	3>=2 = 1 2>=3 = 0	U16(3000)>=I32(5002)
or	OR operator	U16(1031) == 1 or U16(1031) == 2	
and	AND operator	U16(1031) >= 1 and U16(1031) < 3	
Division by 0			
A+B/0	Sets an error in the status line: err=<24/ERR_INVALID_ARGUMENT>		
F(5000)*F(5002)/F(5004)	Sets an error in the status line if register 5004 returns '0'		

Table 25: Mathematical and logical operations

The number format of the result of a mathematical or logical operation always depends on the data type (page-item type) of the relevant field. While an 'integer' is a whole number without any decimal places, a 'floating point' always has decimal places.

IF statements

An example of an IF statement is: Register 7000 must always be positive.

Entry	Possible results
if F(7010) >= 0 then x = F(7010) else x = 0 end	<ul style="list-style-type: none"> ■ F(7010) = 33.12345 → 33.12345 ■ F(7010) = -33.1234 → 0

Table 26: IF statement

Changing the Modbus byte order

The notation for the Modbus byte order is as follows:

Data type(register address, 8-digit byte order)

Example: Register U32(5000,12345678) = 89ABCDEF hex

Register U64(9000,12345678) = 1234567890ABCDEF hex

If the byte order is to be changed, it must always be specified with 8 digits, even if the data type has fewer bytes. Non-existent digits are ignored:

Notation	Modbus byte order
U32(5000, 1234 5678)	→ 89ABCDEF hex
U32(5000, 5678 1234)	→ 89ABCDEF hex
U32(5000, 8765 4321)	→ EFCDAB89 hex
U32(5000, 4321 8765)	→ EFCDAB89 hex
U32(5000, 2134 8765)	→ AB89CDEF hex
U32(5000, 3421 8765)	→ CDEFAB89 hex
U32(5000, 4132 8765)	→ EF89CDAB hex
U32(5000, 1234)	→ Error: New byte order must have 8 digits
U64(9000, 12346578)	→ 1234567890ABCDEF hex
U64(9000, 87654321)	→ EFCDAB9078563412 hex

Table 27: Notation for changing the Modbus byte order

8.6.5 Backup GQ Modbus client

All the settings described in the previous section 8.6.4 "Main GQ Modbus client" can be made on the menu page **3.70 Backup GQ Modbus client**. The backup device provides redundancy to ensure the availability of the gas quality data.

- ▶ For data from the backup device to be retrieved and used, select the setting **Modbus client redundant** at coordinate **3.10.10 GQ mode** in the menu **3.10 GQ setting**. Without this setting, the data from the backup device is only read and displayed, but not evaluated and, if applicable, archived.

8.6.6 Main / backup GQ Modbus server

The Modbus servers can be written to by external Modbus clients with GQ data that can then be used for volume conversion. These values can be viewed on the menu pages 3.80 Main GQ Modbus server and 3.90 Backup GQ Modbus server.

8.6.7 GQ DSfG

On the menu page **3.200 GQ DSfG**, settings can be made for transferring the gas quality data over the DSfG bus.

Access	Coords	Name	Value	Unit	Details
🔒	3.200.10	Query type	GERG88-capable		ⓘ
🔒	3.200.20	PGC instance type	Q instance		ⓘ
🗑️	3.200.30	Standard query mode	GERG88 Q instance		ⓘ
🔒	3.200.40	Start behaviour	Start without error		ⓘ
🔒	3.200.70	Communication timeout	60	PRESET s	ⓘ
🔒	3.200.80	Max. repetition communication	3	PRESET	ⓘ
🗑️	3.200.90	GQ display operating mode	Default		ⓘ
🗑️	3.200.100	PGC condition	Inactive		ⓘ
🗑️	3.200.110	Order number	-1		ⓘ
🗑️	3.200.120	Analysis counter	0		ⓘ
🗑️	3.200.130	PGC condition	Inactive		ⓘ
🗑️	3.200.140	Order number	-1		ⓘ
🗑️	3.200.150	Analysis counter	0		ⓘ
🗑️	3.200.160	Bit string	0x00000000	hex	ⓘ
🗑️	3.200.170	Bit string	0x00000000	hex	ⓘ

Fig. 79: Menu page 3.200 GQ DSfG

- ▶ At coordinate **3.200.10**, specify the **query type**. It must be selected so that it matches the gas analyser. The available options are:
 - GERG88-capable
 - AGA8-capable
- ▶ At coordinate **3.200.20**, specify the **PGC instance type**. This must also match the gas analyser. The available options are:
 - Q instance
 - G instance
- ➡ The selections made are shown at coordinate **3.200.30 Standard query mode**.
- ▶ At coordinate **3.200.40 Start behaviour**, specify whether the RFC 7 issues a message at startup if there are no values for the gas quality available. The settings have the following meanings:
 - **Start without error**: A message is **not** issued at startup if there is no gas quality data available.
 - **Start with error**: A message is issued at startup. The message is reset automatically as soon as gas quality data becomes available.
- ▶ At coordinate **3.200.70 Communication timeout**, specify an interval within which the RFC 7 may attempt to retrieve data from the gas analyser before a warning message is issued.
- ▶ At coordinate **3.200.80 Max. repetition communication**, specify the maximum number of data retrieval attempts that are made within the previously defined interval.

8.6.8 Main GQ DSfG

The settings described below can be made on the menu page **3.300 Main GQ DSfG**.

Access	Coords	Name	Value	Unit	Details
3.300.10	Calorific value unit	kWh/m3			
3.300.20	Standard density unit	kg/m3			
3.300.40	PGC instance address	Off			
3.300.50	PGC preset	0	PRESET		
3.300.60	PGC condition	Inactive			
3.300.70	Att M timestamp	1970-01-01T01:00:00			
3.300.80	Archive timestamp	1970-01-01T01:00:00			
3.300.90	Status	IDLE			
3.300.100	Communication timeout	-1			
3.300.110	Communication repetition	-1			
3.300.120	Order number	-1			
3.300.130	Fill level bit string	0x00000000		hex	
3.300.140	Calorific value	0,000		kWh/m3	
3.300.150	Standard density	0,0000		kg/m3	
3.300.160	Density ratio	0,00000			
3.300.170	Carbon dioxide	0,000		mol %	
3.300.180	Hydrogen	0,000		mol %	
3.300.190	Nitrogen	0,000		mol %	

Fig. 80: Menu page 3.300 Main GQ DSfG

- ▶ At coordinate **3.300.10**, specify the **unit** for the **calorific value**. This must match the unit used in the gas analyser.
- ▶ At coordinate **3.300.20**, specify the **unit** for the **standard density**. This must match the unit used in the gas analyser.
- ▶ At coordinate **3.300.40**, select the **instance address** of the gas analyser (**PGC**).
- ▶ At coordinate **3.300.50 PGC preset**, set a default value as the preset for calculating the CRC checksum at the end of a telegram. This value must match the value used in the gas analyser.

8.6.9 Backup GQ DSfG

All the settings described in the previous section 8.6.8 "Main GQ DSfG" can be made for the backup device on the menu page **3.400 Backup GQ DSfG**. The backup device provides redundancy to ensure the availability of the gas quality data.

- ▶ For data from the backup device to be retrieved, select the setting **DSfG-A redundancy** at coordinate **3.10.10 GQ mode** in the menu **3.10 GQ setting**.

8.7 Volume encoder – defining parameters

8.7.1 Meter factor

A meter factor is generally used for mechanical gas meters such as turbine-wheel gas meters. It describes the parallel shift in the flow rate characteristic curve as a function of the pulse count, caused by the installation of adjustment wheels in the meter head. The value of the meter factor (Kv factor) is indicated on the rating plate of every gas meter.

Proceed as follows to enter the meter factor (Kv factor) for your gas meter:

- Navigate to the menu page **4.12 Meter factor**.

Access	Coords	Name	Value	Unit	Details
🔒	4.12.10	Main channel Kv factor	6600,00000 PRESET	Pulses/m3	ⓘ
🔒	4.12.20	Reference channel Kv factor	500,00000 PRESET	Pulses/m3	ⓘ

Fig. 81: Menu page 4.12 Meter factor

NOTE

Entering the Kv factor for the main and reference channels

Whether two different Kv factors need to be entered for the main and reference channels depends on your selection at coordinate **2.5.80 Volume encoder mode** on the menu page 2.5 Flow rate parameters.

- Check the setting at coordinate **2.5.80**.
 - If the **2-channel** mode is selected, Kv factors must be entered for both the main **and** the reference channel.
-
- Enter the required Kv factors at coordinates **4.12.10** and, if applicable, **4.12.20**.
 - ➔ The entered Kv factor is now incorporated into the determination of the uncorrected volume at measured conditions.

8.7.2 Characteristic curve

The characteristic curve of flow rate measuring devices such as turbine-wheel gas meters is generally not linear. Instead, it follows a typical profile. Proceed as follows to correct the flow rate characteristic curve:

- Navigate to the menu page **4.14 Characteristic curve**.

Access	Coords	Name	Value	Unit	Details
🔒	4.14.10	Separation flow operating point	100.0 PRESET	m3/h	ⓘ
🔒	4.14.20	Maximum deviation to separation flow	4.000 PRESET	%	ⓘ
🔒	4.14.30	Maximum deviation from separation flow	2.000 PRESET	%	ⓘ
🔒	4.14.40	Deviation at operating point after correction	0.000	%	ⓘ
🔒	4.14.50	Deviation too large mode	Without correction		ⓘ
🔒	4.14.60	Deviation at operating point according to approved accuracy	0.000	%	ⓘ
🔒	4.14.61	Freeze deviation at operating point according to approved accuracy	0.000	%	ⓘ
🔒	4.14.70	Flow rate at measured conditions as a percentage	0.000	%	ⓘ
🔒	4.14.71	Freeze flow rate (M) as a percentage	0.000	%	ⓘ
🔒	4.14.90	Current Kv factor	6600.00000	Pulses/m3	ⓘ
🔒	4.14.91	Freeze current Kv factor	0.00000	Pulses/m3	ⓘ
🔒	4.14.95	Approved accuracy error			ⓘ
🔒	4.14.140	Interpolation point 1	5.0 PRESET	%	ⓘ
🔒	4.14.150	Correction point 1	1.0 PRESET	%	ⓘ
🔒	4.14.160	Interpolation point 2	10.0 PRESET	%	ⓘ
🔒	4.14.170	Correction point 2	0.5 PRESET	%	ⓘ
🔒	4.14.180	Interpolation point 3	25.0 PRESET	%	ⓘ
🔒	4.14.190	Correction point 3	0.2 PRESET	%	ⓘ
🔒	4.14.200	Interpolation point 4	40.0 PRESET	%	ⓘ

Fig. 82: Menu page 4.14 Characteristic curve

- At coordinate **4.14.10 Transitional flow rate operating point**, enter the value for Q_t from the calibration curve (calibration certificate) determined during calibration.
- At coordinate **4.14.20 Maximum deviation to transitional flow rate**, enter the maximum permissible percentage deviation of the flow rate up to the transitional flow rate operating point.
- At coordinate **4.14.30 Maximum deviation from transitional flow rate**, enter the maximum permissible percentage deviation of the flow rate from the transitional flow rate operating point onwards.

NOTE

No characteristic curve correction for measuring devices with integrated electronics

Some measuring devices with integrated electronics already perform characteristic curve correction internally. The transferred values should not, therefore, be corrected further.

- At the dropdown menu of coordinate **2.5.100 Kv factor mode (chapter 4)**, select the setting **'Constant'**.

There are 2 correction variants for all other measurement methods:

- Interpolation point correction
- Polynomial correction



The selection of which correction is to be carried out is made at the dropdown menu of coordinate **2.5.100 Kv factor mode (chapter 4)**; see section 8.5.5 "Flow rate – defining parameters".

1. Interpolation point correction

The flow rate measurement range is split into 15 sub-ranges. The interpolation points that bound these sub-ranges can be distributed individually across the entire measurement range by entering a percentage value relative to the full scale value. This option allows, for example, more interpolation points to be set in the lower part of the measurement range and fewer in the upper part of the measurement range.

If fewer interpolation points are to be set, the value '-1' must be entered at the relevant interpolation point coordinates. Interpolation points marked with this value are ignored.

An example of entering the interpolation point correction is given below.

The example uses 6 interpolation points, in which the following different deviations are taken into account:

	Interpolation point 1	Interpolation point 2	Interpolation point 3	Interpolation point 4	Interpolation point 5	Interpolation point 6
Position of interpolation point [%]	5	10	25	40	70	100
Deviation at correction point [%]	1.0	0.5	0.2	0.0	0.1	0.0

Table 28: Sample values for an interpolation point correction

The figure below shows the profile:

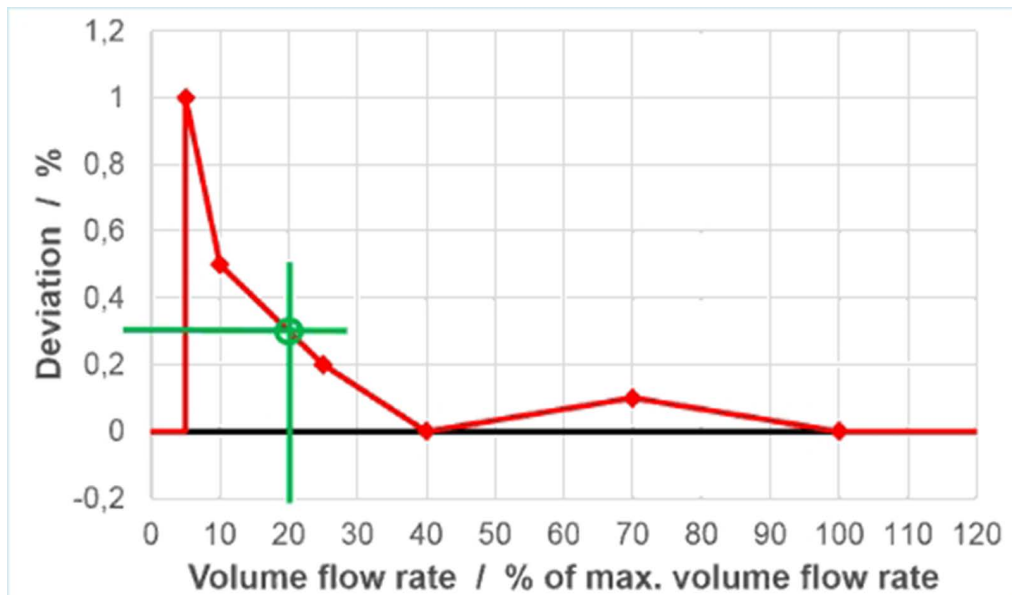

Fig. 83: Profile of the interpolation point correction

The following calculation formula applies to the correction:

$$Displayed\ value = \frac{Measured\ value}{(1 + Deviation)}$$

Sample calculation for a flow rate of 20% of the full scale value (highlighted in green in fig. 83):

$$Displayed\ value = \frac{Measured\ value}{(1 + 0,003)} \approx Measured\ value \times 0,997$$

Correction is not performed outside the range that correction values are available in, i.e. below 5% and above 100%. In other words, the correction value is set to '0'.

A correction with a different number of interpolation points is calculated in the same way as described above.

2. Polynomial correction

For a polynomial correction, the manufacturer of the measuring device determines the corresponding percentage deviations for fixed percentage flow rate values. These values are used to calculate a polynomial function that reflects the profile through these points as ideally as possible. In this case, the value of the function counts as the reciprocal correction value, in the same manner as the interpolation point correction. The polynomial coefficients are supplied by the manufacturer.

- ▶ Enter the manufacturer coefficients at coordinates **4.14.460 to 4.14.500**.

The maximum deviation set at coordinate 4.14.30 applies regardless of the type of correction (interpolation point or polynomial correction). If the deviation at an operating point is greater than the set value, then the correction for that operating point or operating range is set to '0'. In other words, correction is not performed.

NOTE

Behaviour of the polynomial correction at very low flow rate values

The polynomial correction can exhibit very large overshoots at very low flow rate values ($X \rightarrow 0$). They are, however, easy to correct using low-flow cut-off suppression.

- ▶ Set low-flow cut-off suppression at coordinate 2.6.60.

8.7.3 Modbus client for USM

With the Modbus client for USM protocol, measurement data is transferred from an ultrasonic gas meter to the flow computer.

Proceed as follows to configure the Modbus connection settings and define the Modbus addresses for the ultrasonic gas meter:

- ▶ Navigate to the menu page **4.15 Modbus client for USM**.

RFC 71		RFC 7 Bdh		4. Volume encoder -> 15 Modbus client for USM		2026-03-17 14:05:12		EN	
Text search		Access	Coords	Name	Value	Unit	Details		
1. Overviews			4.15.10	Mode	Off				
2. Conversion			4.15.20	Debug info	Off				
3. Gas quality (GQ)			4.15.30	Byte order	Big 1234				
4. Volume encoder			4.15.40	Register offset	0	PRESET			
4.12 Meter factor			4.15.50	Address offset	1	PRESET			
4.14 Characteristic curve			4.15.60	Modbus ID	1	PRESET			
4.15 Modbus client for USM			4.15.70	Server accepts gaps	No				
4.16 Archive data (Modbus client)			4.15.80	Max. gap size	20	PRESET			
4.100 Counter readings (Modbus client)			4.15.90	Read function code	Function code 3				
4.500 Synchronisation monitoring			4.15.110	IP4 address		PRESET			
5. Outputs			4.15.120	TCP port	502	PRESET			
6. Inputs			4.15.130	Modbus cycle delay	0,5	PRESET	s		
7. User data			4.15.140	Modbus client default setting	SELECT PREALLOCATION				
8. Check			4.15.150	Client condition	Off				
9. System settings			4.15.160	Status	IDLE				
11. Maximum load			4.15.190	Transaction status	Idle				
12. Factory settings			4.15.200	Measured value counter	0				
40. DSIG archive			4.15.210	Last measurement timestamp	1970-01-01T01:00:00				
50. Miscellaneous			4.15.220	Free counter	0				

Fig. 84: Menu page 4.15 Modbus client for USM



On the menu page **4.15 Modbus client for USM**, the individual parameters must be entered or selected in the same manner as described in section 8.6.4 "Main GQ Modbus client". Parameter entry or selection is therefore not described in detail here.

- Make the required settings or selections at coordinates **4.15.10 to 4.15.130**.

Since various types of ultrasonic gas meter can be connected to the flow computer, communication between the devices must also be configured individually.

For this purpose, various default settings can be selected at the dropdown menu of coordinate **4.15.140 Modbus client default setting** (see fig. 85), so that the corresponding preset Modbus registers are entered for each measuring component.

Proceed as follows to do this:

- Open the dropdown menu of coordinate **4.15.140 Modbus client default setting**.

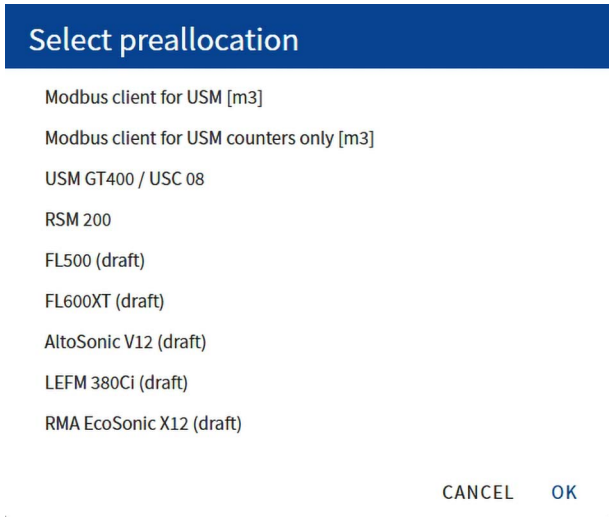

Fig. 85: Dropdown menu of coordinate 4.15.140

- ▶ Select the required communication path and confirm your selection by clicking on the **OK** button.
 - ➔ The Modbus registers are entered for each measuring component; see fig. 86. All fields with changed values are highlighted with a light blue background.

Access	S	Coords	Name	Value	Unit	Details
✗		4.15.252	Complete unit system identifier			i
✗		4.15.253	Unit system identifier formula status			i
✗		4.15.260	Volume flow	0,0	m3/h	i
👤		4.15.261	Volume flow formula	F(32768) PRESET		i
✗		4.15.262	Complete volume flow formula			i
✗		4.15.263	Volume flow formula status			i
✗		4.15.270	Gas velocity	0,0	m/s	i
👤		4.15.271	Gas velocity formula	F(32770) PRESET		i
✗		4.15.272	Complete gas velocity formula			i
✗		4.15.273	Gas velocity formula status			i
✗		4.15.280	Sound velocity	0,0	m/s	i
👤		4.15.281	Sound velocity formula	F(32772) PRESET		i
✗		4.15.282	Complete sound velocity formula			i
✗		4.15.283	Sound velocity formula status			i
✗		4.15.290	FR1 total gas volume	0,0	m3	i
👤		4.15.291	FR1 total gas volume formula	U32(32774) PRESET		i
✗		4.15.292	Complete FR1 total gas volume formula			i
✗		4.15.293	FR1 total gas volume formula status			i

Fig. 86: Menu page 4.15 Modbus client for USM – entered Modbus registers

The **default setting** assigns uniform Modbus addresses to all ultrasonic gas meters. If the manufacturer of an ultrasonic gas meter offers transfer of the measured values over Modbus client for USM protocol, transfer of the essential parameters is guaranteed. Where applicable, the RFC 7 even handles certain further calculations that Modbus client for USM would actually require, and completes the database for any subsequent onward data transfer over this protocol.

NOTE

Checking the Modbus addresses

Since the ultrasonic gas meters from different manufacturers are designed differently and have different measurement-path configurations, some values may be identical, while other calculation variables may differ. Incorrect entry of Modbus addresses can lead to nonsensical calculation values.

- ▶ If necessary, please consult the operating manual for the relevant manufacturer’s ultrasonic gas meter.
- ▶ Carefully check the addresses of the individual measuring components on your volume transmitter to ensure that they match the Modbus addresses in the flow computer. Where possible, use the original protocol for the Modbus addresses on the ultrasonic gas meter you have installed.
- ▶ Once the Modbus-specific settings have been made, please do not change them again, as otherwise correct acceptance of the values from the ultrasonic gas meter can no longer be guaranteed.

Regardless of the lists of default settings, further settings can be made or mathematical calculations can be programmed in the input fields of the individual measuring components containing the term ‘formula’ in the coordinate name.



The programming options are described in detail in section 8.6.4 "Main GQ Modbus client".

8.7.4 Counter readings (Modbus client)

Proceed as follows to view the meter readings transferred over the Instance F protocol:

- ▶ Navigate to the menu page **4.100 Counter readings (Modbus client)**.

Access	Coords	Name	Value	Unit	Details
×	4.100.10	Cycle quantity	0,0	m3	i
×	4.100.20	Parameter timeout	Yes		i
×	4.100.30	Timeout	-1	s	i
🔒	4.100.40	Max. timeout	15	PRESET s	i
×	4.100.50	Timestamp timeout	0		i
×	4.100.70	BM1 counter reading uninterrupted	0,0	m3	i
×	4.100.71	BM1 counter reading interrupted	0,0	m3	i
×	4.100.80	Last BM1 counter reading uninterrupted	0,0	m3	i
×	4.100.81	Last BM1 counter reading interrupted	0,0	m3	i
×	4.100.90	BM1 counter reading uninterrupted timestamp	0		i
×	4.100.91	BM1 counter reading interrupted timestamp	0		i
×	4.100.100	Last BM1 counter reading uninterrupted timestamp	0		i
×	4.100.101	Last BM1 counter reading interrupted timestamp	0		i
×	4.100.110	BM1 cycle quantity uninterrupted	0,0	m3	i
×	4.100.111	BM1 cycle quantity interrupted	0,0	m3	i
×	4.100.140	BM2 counter reading uninterrupted	0,0	m3	i
×	4.100.141	BM2 counter reading interrupted	0,0	m3	i
×	4.100.150	Last BM2 counter reading uninterrupted	0,0	m3	i

Fig. 87: Menu page 4.100 Counter readings (Modbus client)

- ▶ At coordinate **4.100.40 Max. timeout**, specify the corresponding value.

8.7.5 Synchronisation monitoring

Synchronisation monitoring is a quantity-based comparison of the flow rate at measured conditions between the main channel and the reference channel of a multi-channel turbine-wheel gas meter.

The signal used as the main channel and the signal used as the reference channel are specified at coordinate **2.5.80 Volume encoder mode** (see section 8.5.5 "Flow rate – defining parameters"). The signal listed first in the selection serves as the main channel, and the signal listed second is used as the reference channel.

Sample selection in coordinate 2.5.80 Volume transmitter mode:

- ▶ **HF / 1-channel / Enco**
 - ➔ The single-channel HF signal is used as the main channel.
 - ➔ The encoder signal is used as the reference channel.

Depending on the volume encoder mode, the main and reference channels may have different meter factors (e.g. with the **HF / 2-channel / 1 to 1** selection (see section 8.7.1 "Meter factor"). Or, for example with the **Enco / HF / 1-channel** selection, the original counter reading (Vo) is compared with the volume at measured conditions determined using the HF signal (see section 8.5.5 "Flow rate – defining parameters").

For devices that transfer pulses only, the second pulse input is used for redundancy purposes in case the first pulse input fails.

The parameters for synchronisation monitoring can only be set when the calibration switch is unlocked. Proceed as follows to do this:

- ▶ Navigate to the menu page **4.500 Synchronisation monitoring**.

Access	Coords	Name	Value	Unit	Details
🔒	4.500.10	Mode	On		ⓘ
✕	4.500.40	Comparison channels	Enco / HFX		ⓘ
✕	4.500.150	Comparison quantity Main	15,33	m3	ⓘ
✕	4.500.160	Reference comparison quantity	0,00	m3	ⓘ
✕	4.500.170	Comparison error percentage	100,00	%	ⓘ
✕	4.500.180	Comparison error absolute	15,33	m3	ⓘ
✕	4.500.210	Counter channel	Counting operation		ⓘ
✕	4.500.220	Synchronisation current status	Running		ⓘ
✕	4.500.230	Last status	Stationary		ⓘ
✕	4.500.240	Counter OK	0		ⓘ
✕	4.500.250	Counter error	45		ⓘ
✕	4.500.255	Counter for main/reference switchovers	91		ⓘ
🔒	4.500.260	Normal abort quantity	1000,00	PRESET m3	ⓘ
🔒	4.500.270	Abort quantity after error	100,00	PRESET m3	ⓘ
🔒	4.500.280	Max. deviation	4,00	PRESET %	ⓘ
✕	4.500.290	Max. deviation absolute	40,00	m3	ⓘ

Fig. 88: Menu page 4.500 Synchronisation monitoring

- ▶ If synchronisation monitoring is to be carried out, activate it by selecting **On** at coordinate **4.500.10 Mode**.
 - ➔ At coordinate **4.500.40 Comparison channels**, the main and reference channels selected at coordinate **2.5.80 Volume encoder mode** in the menu **2.5 Flow rate parameters** are shown.

The table below shows what data is displayed at the further coordinates:

Coordinate	Name	Displayed value
4.500.150	Main comparison volume	■ Cumulative volume at measured conditions recorded by the main channel, in [m ³]
4.500.160	Reference comparison volume	■ Cumulative volume at measured conditions recorded by the reference channel, in [m ³]
4.500.170	Percentage comparison error	■ Percentage deviation between the main and reference comparison volumes, in [%]
4.500.180	Absolute comparison error	■ Absolute deviation between the main and reference comparison volumes, in [m ³]
4.500.210	Counter channel	■ Indicates which channel is currently being used to calculate e.g. the volume at base conditions in the counters.
4.500.220	Current state	■ Shows the current synchronisation monitoring state, e.g. Runs / Halts or OK / Error
4.500.230	Last state	■ Shows the last synchronisation monitoring state, e.g. Runs / Halts or OK / Error
4.500.240	OK counter	■ Shows how often the synchronisation monitoring state has switched to 'OK'.
4.500.250	Error counter	■ Shows how often the synchronisation monitoring state has switched to 'Error'.
4.500.255	Main / reference switchover counter	■ Shows the number of switchovers between the main and reference channels.

Table 29: Coordinates and their function in the menu 4.500 Synchronisation monitoring

- ▶ At coordinate **4.500.260**, specify the **normal cut-off volume**. The **normal cut-off volume** specifies the volume at measured conditions up to which the values of each channel are accumulated. Once this volume is reached, a new sum interval begins, i.e. counting starts again at 'zero'. This only happens, however, if no impermissible deviations between the main and reference channels have occurred within the interval. (See coordinate 4.500.280 Max. deviation). The corresponding unit matches the selection at coordinate 2.1.110 Volume at measured conditions.
- ▶ At coordinate **4.500.270**, specify the **cut-off volume after an error**. The **cut-off volume after an error** specifies the volume at measured conditions up to which the values of each channel are accumulated – following the occurrence of an impermissible deviation (error). Once this volume is reached, coordinate 4.500.210 Counter channel switches back to the main channel. This only happens, however, if no further impermissible deviations between the main and reference channels have occurred within the interval. (See coordinate 4.500.280 Max. deviation). The corresponding unit matches the selection at coordinate 2.1.110 Volume at measured conditions.
- ▶ At coordinate **4.500.280**, specify the **maximum permissible percentage deviation** between the main and reference comparison volumes.
 - ➔ If this maximum permissible deviation is exceeded, the system automatically switches at coordinate **4.500.210 Counter channel** to the channel with the larger volume.
 - ➔ The value for coordinate **4.500.290 Max. absolute synchronisation deviation** is calculated automatically from the entered maximum permissible percentage deviation and the specified normal cut-off volume.

8.8 Inputs – defining parameters

8.8.1 Digital inputs 1 and 2 – defining parameters

The parameters for the digital inputs DI1 and DI2 can only be changed when the calibration switch is unlocked.

The digital inputs are located on the following terminal strip (see section 6.2.2 "Terminal assignments of the terminal strips"):

- Digital input DI1 on **terminal strip X6, terminal nos. 1 and 2**
- Digital input DI2 on **terminal strip X6, terminal nos. 3 and 4**

Proceed as follows to set the parameters:

- Depending on the digital input to be set, navigate to the corresponding menu page. Here, by way of example: **6.10 Digital input 1 (DI1)**.

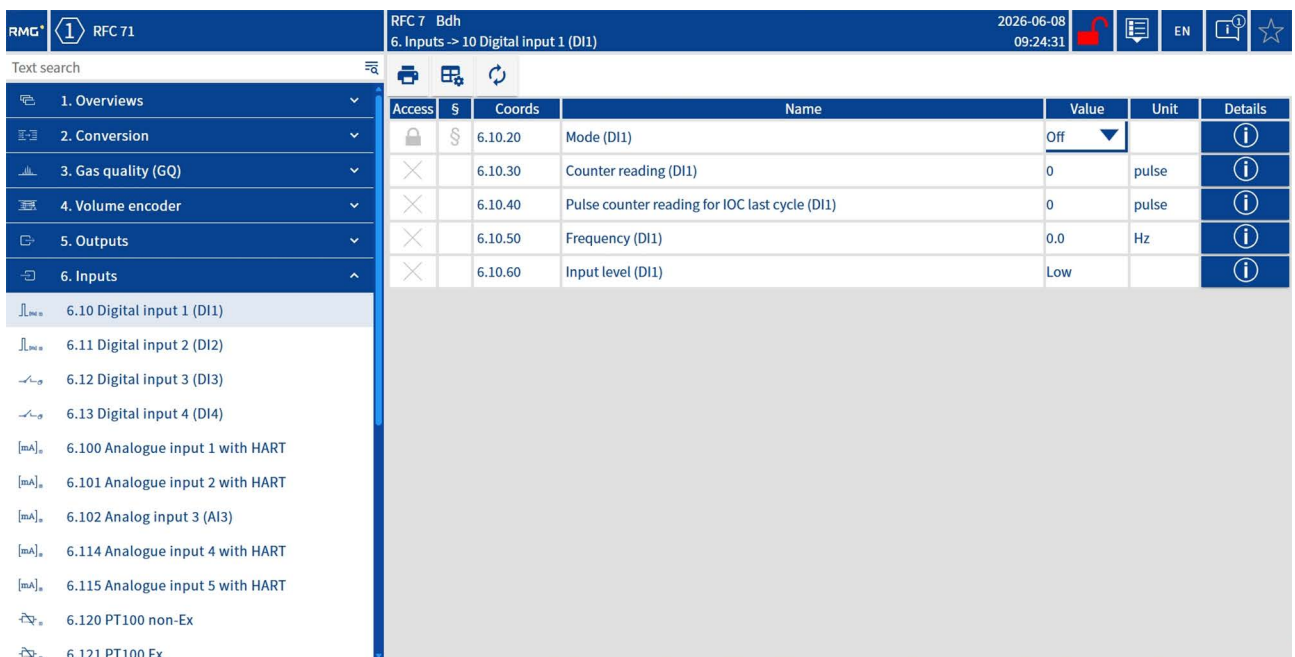

Fig. 89: Menu page 6.10 Digital input 1 (DI1)

- At coordinate **6.10.20**, specify the digital input's **mode**. The available options are:
 - Off
 - HF
 - Fixed simulation (for test purposes only)
 - Dynamic simulation (for test purposes only)

8.8.2 Analogue inputs – defining parameters

The parameters for the analogue inputs AI1 – AI5 can only be changed when the calibration switch is unlocked.

The analogue inputs are located on the following terminal strips (see section 6.2.2 "Terminal assignments of the terminal strips"):

- Analogue inputs AI1 – AI3 on terminal strip X3
- Analogue inputs AI4 – AI5 on terminal strip X7 (intrinsically safe version)

Proceed as follows to set the parameters:

- ▶ Depending on the analogue input to be set, navigate to the corresponding menu page. Here, by way of example: **6.100 Analogue input 1 with HART (AI1)**.

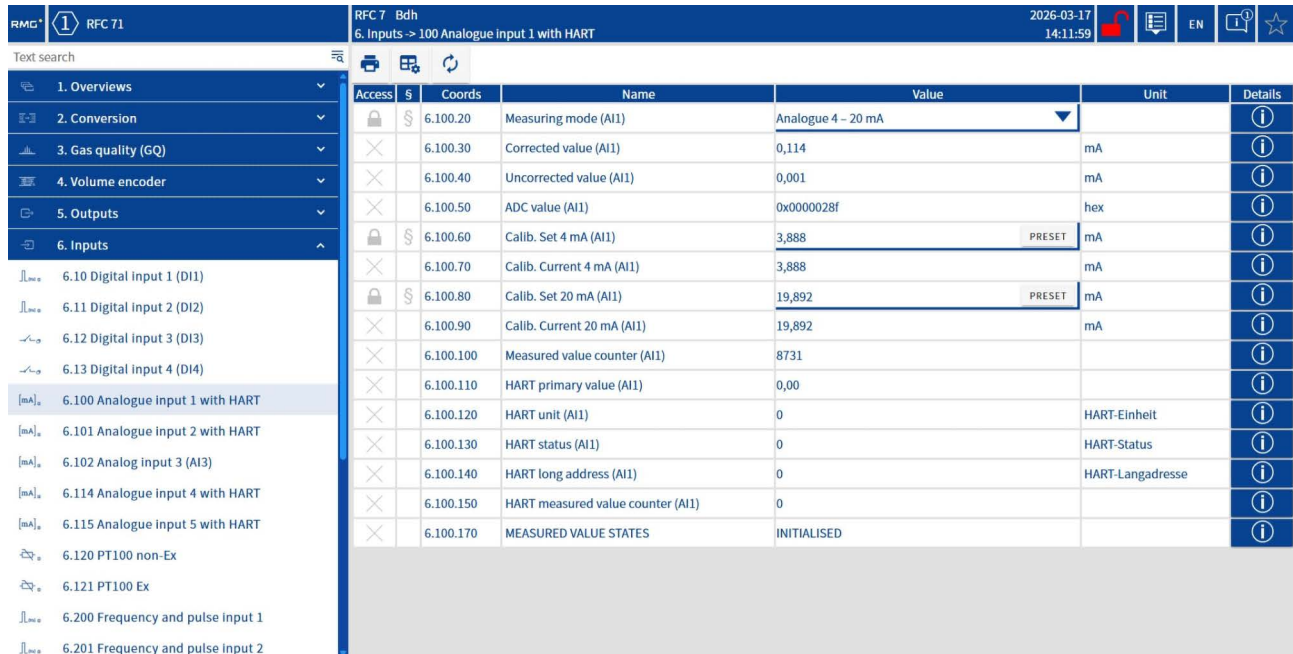

Fig. 90: Menu page 6.100 Analogue input 1 with HART (AI1)

- ▶ At the dropdown menu of coordinate **6.100.20 Measuring mode (AI1)**, select the corresponding setting:
 - Off
 - Analogue 4 – 20 mA
 - HART
 - Calib. 4 mA
 - Calib. 20 mA
- ▶ For all unused analogue inputs, please set the **Measuring mode** coordinate on the relevant menu page to **Off**.
- ▶ If the analogue inputs AI1 and AI2, and AI4 and AI5, are to be used with the HART interface for processing digital signals, the setting **HART** should be selected.
 - ➔ The corresponding analogue input is then used with the HART interface.

Proceed as follows to calibrate the analogue input AI1, for example:

1. Apply a current of 4 mA at the analogue input AI1 on terminal strip X3.
2. At coordinate **6.100.20 Measuring mode (AI1)**, select the setting **Calib. 4 mA**.
 - ➔ The current value is shown at coordinate **6.100.70 Calib. 4 mA (current) (AI1)**.
3. Enter the displayed value at coordinate **6.100.60 Calib. 4 mA (set) (AI1)**.
4. Repeat steps 1 to 3 for the 20 mA value at coordinates **6.100.80** and **6.100.90**.
5. Finally, specify the desired **measuring mode** again at coordinate **6.100.20**.

8.8.3 PT100 – defining parameters

The parameters of the PT100 (resistance measurement) can only be changed when the calibration switch is unlocked.

The connections in the intrinsically safe (Ex) version are located on terminal strip X8, and the connections in the **non**-intrinsically safe version are located on terminal strip X4 (see section 6.2.2 "Terminal assignments of the terminal strips").

Proceed as follows to set the parameters:

- ▶ For the intrinsically safe version, navigate to the menu page **6.121 PT100 Ex**.
- ▶ For the non-intrinsically safe version, navigate to the menu page **6.120 PT100 non-Ex**.

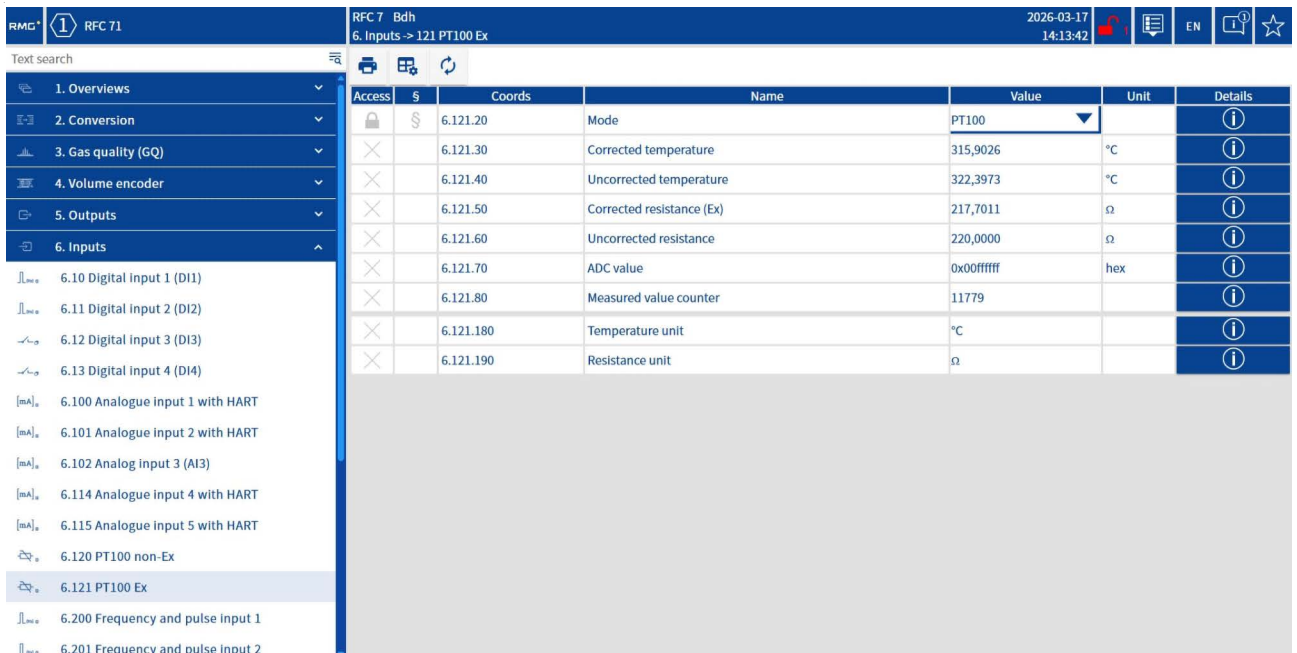

Fig. 91: Menu page 6.121 PT100 Ex

How to set the parameters is explained below using the menu page **6.121 PT100 Ex** as an example:

- ▶ Set the PT100 mode at the dropdown menu of coordinate **6.121.20 Mode**. The following modes are available:
 - Off
 - PT100
 - Calibration
 - Simulation (for test purposes only)

If line-break monitoring is to be performed, a 4-wire resistor must be used.

Carrying out calibration

Either a temperature bath or a block calibrator can be used to calibrate the PT100, allowing the temperature setpoints for the PT100 to be set.



- ▶ At coordinate **6.121.20 Mode**, select the setting **Calibration** and save it.
 - ➔ The view of the menu page **6.121 PT100 Ex** changes (see fig. 92).

Access	\$	Coords	Name	Value	Unit	Details
🔒	§	6.121.20	Mode	Calibration		ⓘ
×		6.121.30	Corrected temperature	315,9026	°C	ⓘ
×		6.121.40	Uncorrected temperature	322,3973	°C	ⓘ
×		6.121.50	Corrected resistance (Ex)	217,7011	Ω	ⓘ
×		6.121.60	Uncorrected resistance	220,0000	Ω	ⓘ
×		6.121.70	ADC value	0x00ffffff	hex	ⓘ
×		6.121.80	Measured value counter	11869		ⓘ
🔒	§	6.121.90	Lower temperature setpoint	-20,0000 PRESET	°C	ⓘ
🔒	§	6.121.100	Upper temperature setpoint	60,0000 PRESET	°C	ⓘ
🔒	§	6.121.110	Lower temperature actual value	-20,0000 PRESET	°C	ⓘ
🔒	§	6.121.120	Upper temperature actual value	60,0000 PRESET	°C	ⓘ
×		6.121.130	Calculated resistance offset	-0,0000	Ω	ⓘ
×		6.121.140	Calculated resistance gradient	1,0000		ⓘ
×	§	6.121.150	Used resistance offset	1,2108	Ω	ⓘ
×	§	6.121.160	Used resistance gradient	0,9840		ⓘ
🔒	§	6.121.170	Save calibration data	SAVE CALIBRATION DATA		ⓘ
×		6.121.180	Temperature unit	°C		ⓘ
×		6.121.190	Resistance unit	Ω		ⓘ

Fig. 92: Menu page 6.121 PT100 Ex – calibration mode

- ▶ At coordinate **6.121.90**, enter the **lower temperature setpoint** for the PT100 set in the temperature bath or block calibrator used.
- ▶ Read off the temperature value actually measured and enter it at coordinate **6.121.110 Lower temperature actual value**.
- ▶ Repeat the process with the **upper temperature setpoint** and **actual value** (coordinates **6.121.100** and **6.121.120**).



- ▶ Save your entries.
 - ➔ At coordinates **6.121.130 Calculated resistance offset** and **6.121.140 Calculated resistance gradient**, the automatically calculated, required correction values are shown.
- ▶ Click on the **Apply calibration data** button at coordinate **6.121.170** to use the displayed correction values.
 - ➔ The calculated correction values are now applied and shown at coordinates **6.121.150 Used resistance offset** and **6.121.160 Used resistance gradient**.
- ▶ Exit calibration mode by selecting and saving a different setting at coordinate **6.121.20 Mode**.

8.8.4 Frequency and pulse input – defining parameters

The parameters for frequency and pulse inputs 1 and 2 can only be changed when the calibration switch is unlocked.

The inputs are located on the following terminal strips (see section 6.2.2 "Terminal assignments of the terminal strips"):

- Reed/Namur pulse input 1, **terminal strip X8, terminal nos. 5 and 6**
- Reed/Namur pulse input 2, **terminal strip X8, terminal nos. 7 and 8**

Proceed as follows to set the parameters:

- ▶ Navigate to the menu page **6.200 Frequency and pulse input 1** to set the main channel.
- ▶ Navigate to the menu page **6.201 Frequency and pulse input 2** to set the reference channel.

Access	\$	Coords	Name	Value	Unit	Details
🔒		6.200.20	Mode (N1)	Off		ⓘ
✕		6.200.30	Pulse counter reading (N1)	0	pulse	ⓘ
✕		6.200.40	Pulse counter reading for IOC last cycle (N1)	0	pulse	ⓘ
✕		6.200.50	Frequency (N1)	0,0	Hz	ⓘ
✕		6.200.60	Input level (N1)	LOW		ⓘ
✕		6.200.70	Error status (N1)	OK		ⓘ
👤		6.200.101	Simulation mode	Fixed		ⓘ
👤		6.200.110	Enco flow rate simulation	60,0 PRESET	% von Qmax	ⓘ
👤		6.200.120	Main flow rate simulation	60,0 PRESET	% von Qmax	ⓘ
👤		6.200.130	Reference flow rate simulation	60,0 PRESET	% von Qmax	ⓘ
👤		6.200.140	Main channel Kv factor simulation	6600,00000 PRESET	Pulses/m3	ⓘ
👤		6.200.150	Reference channel Kv factor simulation	6600,00000 PRESET	Pulses/m3	ⓘ

Fig. 93: Menu page 6.200 Frequency and pulse input 1

How to set the parameters is explained below using the menu page **6.200 Frequency and pulse input 1** as an example:

- ▶ At coordinate **6.200.20**, specify the frequency and pulse input’s **mode**. The available options are:
 - Off
 - LF
 - HF
 - Fixed simulation (for test purposes only)
 - Dynamic simulation (for test purposes only)

Simulation may only be selected for test purposes and is not permitted for use in fiscal applications. If tests are to be carried out outside of use in fiscal applications and a simulation is selected, further settings for the simulation can be made at coordinates **6.200.101** to **6.200.150**. Note that the simulation default settings for both frequency and pulse inputs 1 and 2 and for the encoder are to be entered on this menu page.

8.8.5 Encoder settings

The parameters for the encoder can only be changed when the calibration switch is unlocked.

The input is located on the following terminal strip (see section 6.2.2 "Terminal assignments of the terminal strips"):

- Encoder input, **terminal strip X7, terminal nos. 1 and 2**

Proceed as follows to set the parameters:

- ▶ Navigate to the menu page **6.300 Encoder settings**.

Access	Coords	Name	Value	Unit	Details
🔒	6.300.10	Encoder supply	On		ⓘ
🔒	6.300.20	Encoder mode	Off		ⓘ
🔒	6.300.30	Encoder voltage supply mode	Always on		ⓘ
🔒	6.300.40	Encoder pulse pause time	500	ms	ⓘ
🔒	6.300.110	Encoder counter reading	0.0	m3	ⓘ
🔒	6.300.120	Last encoder counter reading	0.0	m3	ⓘ
🔒	6.300.130	Encoder counter reading timestamp	0		ⓘ
🔒	6.300.140	Last encoder counter reading timestamp	0		ⓘ
🔒	6.300.150	Encoder counter reading change of direction	-1.0	m3	ⓘ
🔒	6.300.160	Encoder status	0x00000000	hex	ⓘ
🔒	6.300.170	Encoder direction	Undetermined		ⓘ
🔒	6.300.180	DSIG status	Substitute value		ⓘ
🔒	6.300.190	Encoder actual timeout	Yes		ⓘ
🔒	6.300.200	Encoder timeout	-1	s	ⓘ
🔒	6.300.210	Max. encoder timeout	10	s	PRESET ⓘ
🔒	6.300.220	Encoder safety factor	8		PRESET ⓘ

Fig. 94: Menu page 6.300 Encoder settings

- ▶ At coordinate **6.300.10 Encoder supply**, select the setting **On** to switch on the power supply.

- ▶ At coordinate **6.300.10**, specify the **encoder's mode**. The available options are:
 - Off
 - On
 - Simulation (for test purposes only)
- ▶ At coordinate **6.300.30 Encoder supply voltage mode**, select the operating mode.
- ▶ At coordinate **6.300.210 Max. encoder timeout**, enter the corresponding value.
- ▶ Specify the **encoder safety factor** at coordinate **6.300.220**.
- ▶ At coordinates **6.300.360** to **.380**, enter the following encoder data:
 - Manufacturer
 - Device type
 - Serial number
- ▶ Some devices can transfer the rating plate information automatically. Activate the transfer by selecting the **From device** setting at coordinate **6.300.350 Rating plate input**.

8.9 Outputs – defining parameters

The parameters for digital outputs 1 and 2 and the analogue outputs can be set by a logged-in user.

The calibration switch must be unlocked to set the parameters of digital outputs 3 to 6.

8.9.1 Digital outputs – defining parameters

The digital outputs are located on the following terminal strips (see section 6.2.2 "Terminal assignments of the terminal strips"):

- Digital outputs 1 and 2, **terminal strip X4, terminal nos. 1 to 4**
- Digital outputs 3 to 6, **terminal strip X5, terminal nos. 1 to 8**

Digital outputs 1 and 2

Please proceed as follows to set the parameters of digital outputs 1 and 2:

- ▶ Navigate to the menu page **5.100 Digital output 1 (DO1)** to set the corresponding output.
- ▶ Navigate to the menu page **5.101 Digital output 2 (DO2)** to set the corresponding output.

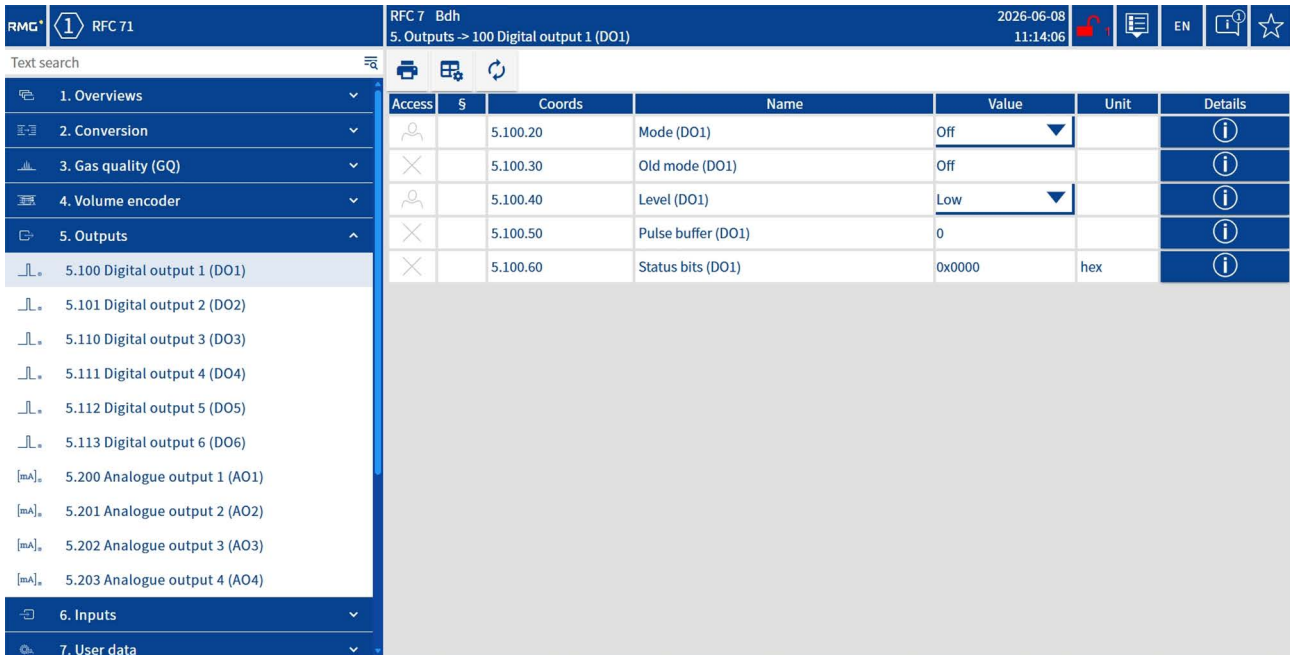

Fig. 95: Menu page 5.100 Digital output 1 (DO1)

How to set **digital output 1 (DO1)** is explained below as an example. Digital output 2 can be configured in the same way:



- ▶ Specify the **mode** at coordinate **5.100.20** and save your setting. The available options are:
 - Off
 - Static
- ➔ The selected, saved mode is shown at coordinate **5.100.30 Old mode (DO1)**.
- ▶ If the **Static** mode has been selected, also set the **level** at coordinate **5.100.40** that a pulse is to be output at. The available options are:
 - Low
 - High

Digital outputs 3 to 6

Please proceed as follows to set the parameters of digital outputs 3 to 6:

- ▶ Depending on the digital output to be set, navigate to the corresponding menu page. Here, by way of example: **5.110 Digital output 3 (DO3)**.

RFC 71		RFC 7 Bdh		2026-06-08 11:17:41		EN	
5. Outputs		5. Outputs -> 110 Digital output 3 (DO3)					
Access	Coords	Name	Value	Unit	Details		
🔒	5.110.20	Mode (DO3)	Off		i		
✕	5.110.30	Mode (DO3)	Off		i		
✕	5.110.40	Too many output pulses (DO3)	176		i		
🔒	5.110.50	Main fault counter assignment (DO3)	Always		i		
🔒	5.110.60	Billing mode assignment (DO3)	Billing mode 1		i		
🔒	5.110.70	Value (DO3)	100.0	PRESET	i		
🔒	5.110.80	Overrun coming (DO3)	100	PRESET	i		
🔒	5.110.90	Overrun going (DO3)	10	PRESET	i		
✕	5.110.100	Cycle quantity (DO3)	0.000000		i		
🔒	5.110.120	Pulse width (DO3)	250.0	PRESET	ms	i	
✕	5.110.130	Pulse count (DO3)	0		i		
✕	5.110.140	Pulse buffer (DO3)	0		i		
✕	5.110.150	Status bits (DO3)	0x0000		hex	i	
✕	5.110.160	Total pulse count (DO3)	0		i		

Fig. 96: Menu page 5.110 Digital output 3 (DO3)

How to set **digital output 3 (DO3)** is explained below as an example. Digital outputs 4 to 6 can be configured in the same way:



- ▶ At coordinate **5.110.20 Mode**, assign a value that digital pulses are to be output for to the digital output and save your setting. The available options are:
 - Off
 - Static
 - Volume at measured conditions
 - Corrected volume at measured conditions
 - Volume at base conditions
 - Energy
- ➔ The selected, saved mode is shown at coordinate **5.110.30 Mode (DO3)**.

The menu page view changes if the **Static** mode has been selected and saved (see fig. 97).

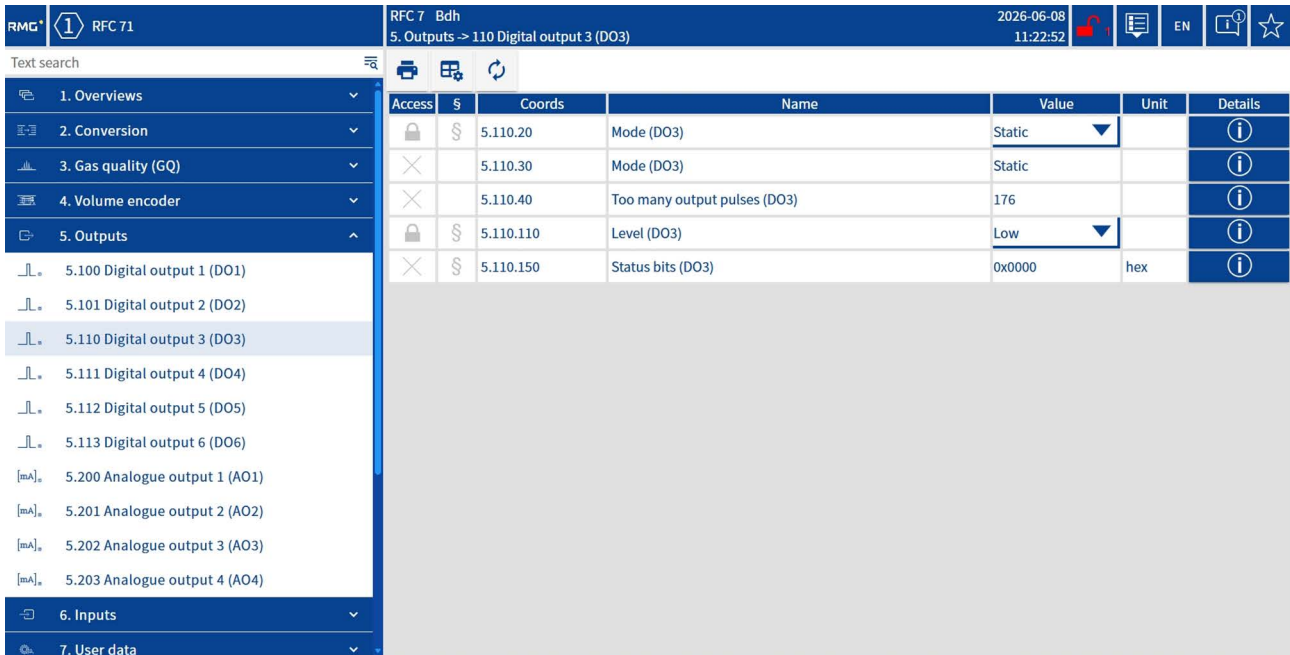

Fig. 97: Menu page 5.110 Digital output 3 (DO3) – ‘Static’ mode

- ▶ Specify the **level** that a pulse is to be output at coordinate **5.110.110**. The available options are:
 - Low
 - High

Further settings need to be made if a physical variable has been selected and saved as the mode. These are explained below using the **volume at measured conditions** mode as an example:

- ▶ At coordinate **5.110.50 Main fault counter assignment**, specify the conditions that the digital output emits pulses for the volume at measured conditions under. The available options are:
 - Always: Pulses are output regardless of the counter in which the volume at measured conditions is recorded.
 - Uninterrupted: Only pulses for the volume at measured conditions recorded in the main counter are output.
 - Interrupted: Only pulses for the volume at measured conditions recorded in the fault counter are output.
- ▶ At coordinate **5.110.60 Billing mode assignment**, specify the billing mode that the digital output is to emit pulses in. The digital output then sends pulses only for the volume at measured conditions recorded in the selected billing mode. The available options are:
 - Undefined billing mode
 - Billing mode 1
 - Billing mode 2
- ▶ At coordinate **5.110.70**, enter the **pulse weight**. The pulse weight defines the quantity of the volume at measured conditions that must be recorded before the digital output emits a pulse. It thus describes the ratio between the measured variable and the pulse. The unit of the pulse weight is thus the unit of the measured variable per pulse (e.g. m³/pulse, kWh/pulse).
 - ➔ A **higher pulse weight** means: fewer pulses (lower resolution).
 - ➔ A **lower pulse weight** means: more pulses (higher resolution).

- ▶ At coordinate **5.110.80**, enter the value for **Overflow starting**. If the measured volume is very high, more pulses per second may need to be output than is technically possible with the set pulse width. In this case, the pulses that cannot be output immediately are stored in an internal memory, known as the overflow.
 - ➔ When the number of stored pulses reaches the value entered at this coordinate, the **Overflow starting** message is issued.
- ▶ At coordinate **5.110.90**, enter the value for **Overflow clearing**. As soon as the pulses are again within the technically possible output frequency, the digital output emits the pulses stored in the overflow in addition to the normal pulse output. This output continues until all the pulses stored in the memory have been transmitted.
 - ➔ When the number of stored pulses falls below the value entered at this coordinate, the **Overflow clearing** message is issued.
- ▶ At coordinate **5.110.120**, enter the value for the desired **pulse width**. The required pulse width (length of the signal) depends on the device that is to receive or process the pulse signal. So, when selecting the pulse width, take the specifications of the receiving device into account.

NOTE

Avoiding measurement distortions caused by excessively high pulse frequencies

If a downstream evaluation unit calculates the actual flow rate from the transferred pulses, exceeding the maximum permissible output frequency (which depends on the defined pulse width) can lead to measurement distortions.

- ▶ Select the pulse weight such that the maximum possible frequency is exceeded only in exceptional cases.

8.9.2 Analogue outputs – defining parameters

The analogue outputs are located on the terminal strip X1 (see section 6.2.2 "Terminal assignments of the terminal strips"):

- Analogue outputs AO1 – AO4, **terminal strip X1, terminal nos. 1 to 8**

Proceed as follows to set the parameters:

- ▶ Depending on the analogue output to be set, navigate to the corresponding menu page. Here, by way of example: **5.200 Analogue output 1 (AO1)**.

Access	Coords	Name	Value	Unit	Details
	5.200.20	Mode (AO1)	Off		
	5.200.30	Input measured value (AO1)	eME::Absolutdruck PRESET		
	5.200.40	Found measured value (AO1)	eME::Absolutdruck		
	5.200.50	Internal measured value (AO1)	167		
	5.200.60	Measured value (AO1)	0,000	bar	
	5.200.70	Start value measuring range (AO1)	0,000 PRESET	bar	
	5.200.80	End value measuring range (AO1)	0,000 PRESET	bar	
	5.200.90	Calculated value (AO1)	0,000	mA	
	5.200.100	Value (AO1)	0,000	mA	
	5.200.110	IOC_CurrentOutmA1	0,000	mA	
	5.200.120	Calib. Set 4 mA (AO1)	4,000 PRESET	mA	
	5.200.130	Calib. Current 4 mA (AO1)	4,000	mA	
	5.200.140	Calib. Set 20 mA (AO1)	19,990 PRESET	mA	
	5.200.150	Calib. Current 20 mA (AO1)	19,990	mA	

Fig. 98: Menu page 5.200 Analogue output 1 (AO1)

How to set **analogue output 1 (AO1)** is explained below as an example. Analogue outputs 2 to 4 can be configured in the same way:

- ▶ At coordinate **5.200.20**, specify the **mode** of analogue output 1 (**AO1**). The available options are:
 - Off
 - Default
 - Calib. 4 mA
 - Calib. 20 mA
 - Measured value 4 – 20 mA
- ▶ At coordinate **5.200.30 Measured value input (AO1)**, enter the physical measured variable to be output by the analogue output.

Procedure for entering the measured value at coordinate 5.200.30



- ▶ Navigate to the menu pages in chapter 2. Volume conversion.
- ▶ Open the menu page of the desired measured value, e.g. 2.3 Gas pressure.
- ▶ Click on the Info button in the Details column.
 - ➔ The Details information window opens.
- ▶ Highlight the value entered for **internalName**, in this example **eME::Absolutdruck** (see fig. 99), and use the Copy and Paste functions (keyboard shortcuts: Ctrl+C and Ctrl+V) to paste the highlighted value into coordinate **5.200.30**.
 - ➔ The pasted measured value is shown at coordinate **5.200.40 Found measured value (AO1)**.

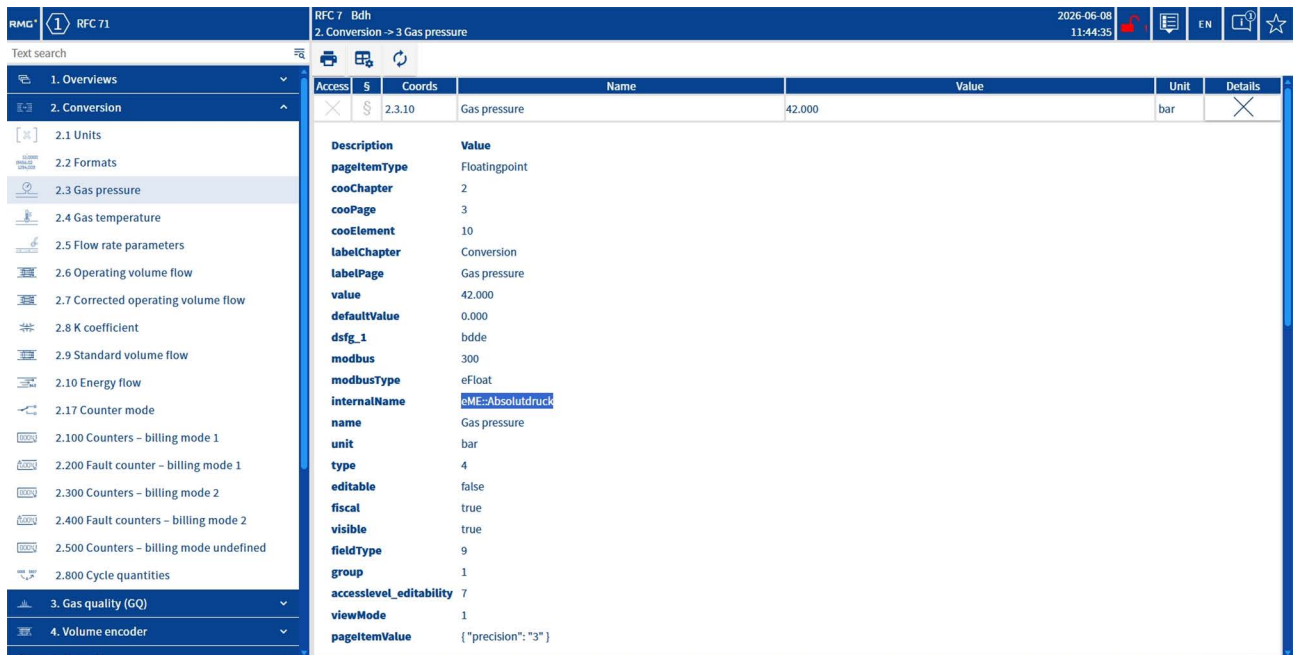

Fig. 99: Details information window for gas pressure

- ▶ At coordinates **5.200.70** and **5.200.80**, specify the **measurement range start and end values**.

Proceed as follows to calibrate the analogue output:

1. At coordinate **5.200.20 Mode (AO1)**, select the setting **Calib. 4 mA**.
 - The current value is shown at coordinate **5.200.130 Calib. 4 mA (current) (AO1)**.
2. Enter the value actually determined by the connected measuring device at coordinate **5.200.120 Calib. 4 mA (set) (AO1)**.
3. Repeat steps 1 and 2 for the 20 mA value at coordinates **5.200.140** and **5.200.150**.
4. Finally, specify the desired **mode** for analogue output 1 again at coordinate **5.200.20**.

8.10 Check – carrying out an functional test

The functional test can be carried out by a logged-in user.

8.10.1 Freeze – defining parameters

The **Freeze** mode offers the option of saving current data for subsequent use. With the Freeze function, the most recent volumes and measured values are, in effect, ‘frozen’.

Proceed as follows to configure the Freeze function:

- ▶ Navigate to the menu page **8.10 Freeze**.

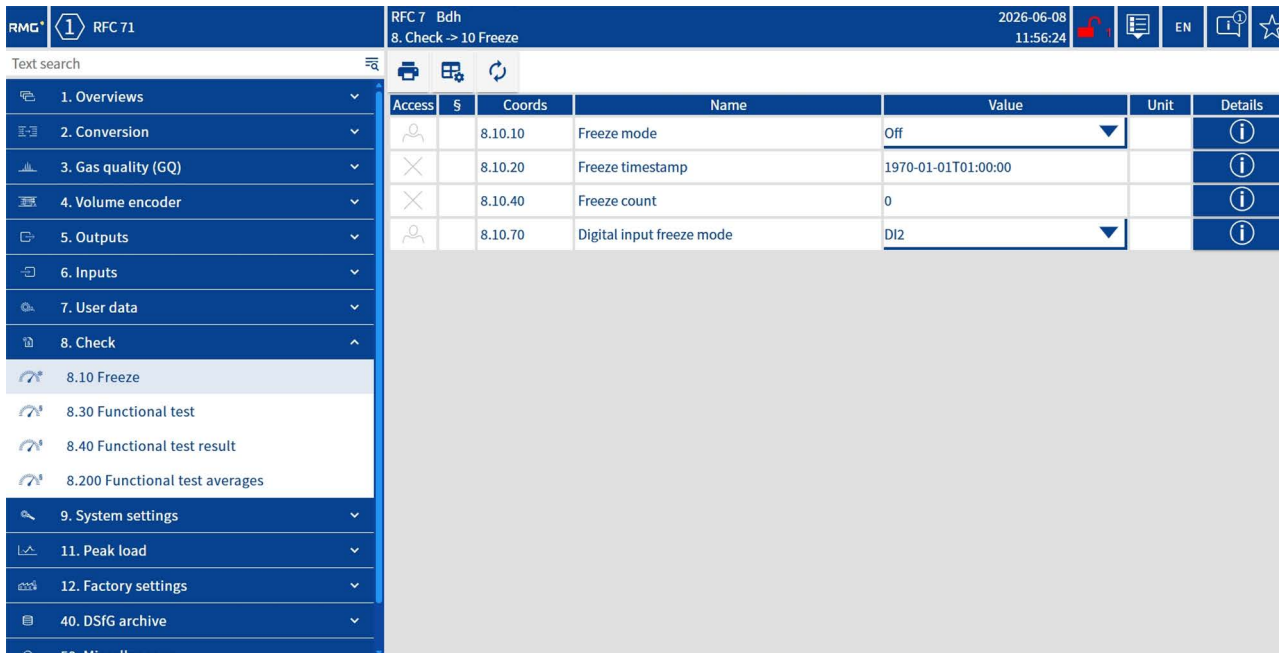

Access	S	Coords	Name	Value	Unit	Details
Person icon		8.10.10	Freeze mode	Off		(i)
X icon		8.10.20	Freeze timestamp	1970-01-01T01:00:00		(i)
X icon		8.10.40	Freeze count	0		(i)
Person icon		8.10.70	Digital input freeze mode	DI2		(i)

Fig. 100: Menu page 8.10 Freeze

- ▶ At coordinate **8.10.10 Freeze mode**, specify when and how often the Freeze function is to be executed. The available options are:
 - Off
 - Manual
 - Cyclical
 - Digital input
 - Every minute
 - Every hour
 - Every day
 - Every gas day
 - Every month
 - Every gas month

- ▶ If **Digital input** is selected, at coordinate **8.10.70 Digital input freeze mode** set which digital input is to be used to trigger the Freeze function. The available options are:
 - DI1
 - DI2
 - DI3
 - DI4

8.10.2 Functional test – defining parameters and carrying out the test

NOTE

Condition for carrying out the functional test

A functional test can only be carried out if there are no alarms present.

- ▶ Before carrying out the functional test, check whether there are any pending alarms or error messages and ensure that no alarm is present.

Proceed as follows to set the parameters for a functional test (a 'revision') and to carry it out:

- ▶ Navigate to the menu page **8.30 Functional test**.

Access	Coords	Name	Value	Unit	Details
✕	8.30.10	Revision status	Stationary		ⓘ
✕	8.30.20	Revision remaining time	-1	sek	ⓘ
✕	8.30.30	Revision message			ⓘ
✕	8.30.40	Revision index	-1		ⓘ
⊞	8.30.50	Revision timestamp 1	1970-01-01T01:00:00	NOW	ⓘ
⊞	8.30.60	Revision timestamp 2	1970-01-01T01:00:00	NOW	ⓘ
⊞	8.30.70	Revision timestamp 3	1970-01-01T01:00:00	NOW	ⓘ
⊞	8.30.80	Revision timestamp 4	1970-01-01T01:00:00	NOW	ⓘ
⊞	8.30.90	Revision start	REVISION START		ⓘ
⊞	8.30.100	Revision delay	60	PRESET sek	ⓘ
⊞	8.30.110	Revision pre-run / post-run	60	PRESET sek	ⓘ
⊞	8.30.120	Revision run time	1200	PRESET sek	ⓘ
⊞	8.30.130	Revision default setting	None		ⓘ
⊞	8.30.140	Start revision	No		ⓘ
✕	8.30.150	FUNCTIONAL TEST STATUS	INITIALISED		ⓘ
✕	8.30.160	Revision delay	None		ⓘ

Fig. 101: Menu page 8.30 Functional test

- ▶ Set the revision's pre-test and post-test phase duration at coordinate **8.30.110 Revision pre-run / post-run**.
- ▶ Set the revision duration at coordinate **8.30.120 Revision run time**.
- ▶ Save your entries by clicking on the corresponding button.
- ▶ At the dropdown menu of coordinate **8.30.130 Revision default setting**, select the desired revision start time. The available options are:
 - **None**: No timestamps are set.



- **Now:** Timestamp 1 at coordinate 8.30.50 is set to the current time. Timestamps 2 – 4 are set according to the entries for pre-test phase, post-test phase and test time.
- **Next minute:** Timestamp 1 at coordinate 8.30.50 is set to the next full minute.
- **Next 10 minutes:** Timestamp 1 at coordinate 8.30.50 is set to the next full 10 minutes.
- **Next hour:** Timestamp 1 at coordinate 8.30.50 is set to the next full hour.



- ▶ Save your settings by clicking on the corresponding button.
 - ➔ The delay time until the revision starts at coordinate 8.30.100 is automatically calculated and entered according to your selected default setting.
 - ➔ The required timestamps are set according to your settings:
 - Coordinate **8.30.50 Revision timestamp 1** shows the time at which the delay ends and the pre-test phase begins.
 - Coordinate **8.30.60 Revision timestamp 2** shows the time at which the pre-test phase ends and the test time begins.
 - Coordinate **8.30.70 Revision timestamp 3** shows the time at which the test time ends and the post-test phase begins.
 - Coordinate **8.30.80 Revision timestamp 4** shows the time at which the post-test phase, and thus the revision, ends.

Once the timestamps have been set according to the default setting, there are two ways to start the revision:

- ▶ Click on the **Revision Start** button.

or

- ▶ At the dropdown menu of coordinate **8.30.140 Start revision**, select the setting **Yes** and save the entry.

Regardless of how the revision was started, the following steps take place:

- ➔ The calculated delay time starts.
- ➔ The current revision **status** is shown at coordinate **8.30.10**.
- ➔ The revision's **remaining time** is shown at coordinate **8.30.20**.
- ➔ Coordinate **8.30.30 Revision message** shows which phase the revision is currently in. Possible indicators are:
 - Phase: Delay
 - Phase: Pre-run
 - Phase: Revision run
 - Phase: Post-run
 - Functional test completed.

An functional test can be cancelled at any time:

- ▶ At the dropdown menu of coordinate **8.30.140 Start revision**, select the setting **Cancel** and save the entry.
 - ➔ The ongoing functional test is cancelled and all the timestamps are reset.

8.10.3 Results of the functional test

- To view the results of the functional test carried out, navigate to the menu page **8.40 Functional test results**.

1 2

3

OFFICIALLY CALIBRATED FUNCTIONAL TEST										
Name	Pre-run			Revision run			Post-run			Unit
	2026-06-08T15:05:00	-		2026-06-08T15:06:30	-		2026-06-08T15:06:30	-		
	Pre-run	ΔV	P1	ΔP1	P2	ΔP2	NL	Post-run		
0 Ultrastamp	1780923900	30	1780923930	60	1780923990	30	1780924020			
1 BM1 Original counter with decimal part	48352.384	0.000	48352.384	0.000	48352.384	0.000	48352.384	0.000	48352.384	m
2 BM1 Volume (M) with decimal part	46922.545001	0.000000	46922.545001	0.000000	46922.545001	0.000000	46922.545001	0.000000	46922.545001	m
3 BM1 Corr. volume (M) with decimal part	46921.331694	0.000000	46921.331694	0.000000	46921.331694	0.000000	46921.331694	0.000000	46921.331694	m
4 BM1 Volume (S) with decimal part	20086.893680	0.000000	20086.893680	0.000000	20086.893680	0.000000	20086.893680	0.000000	20086.893680	x100 m
5 BM1 Energy with decimal part	22684838.052	0.000	22684838.052	0.000	22684838.052	0.000	22684838.052	0.000	22684838.052	kWh
6 BM2 Original counter with decimal part	0.000	0.000	0.000	0.000	0.000	0.000	0.000	0.000	0.000	m
7 BM2 Volume (M) with decimal part	1737.396813	0.000000	1737.396813	0.000000	1737.396813	0.000000	1737.396813	0.000000	1737.396813	m
8 BM2 Corr. volume (M) with decimal part	1736.239319	0.000000	1736.239319	0.000000	1736.239319	0.000000	1736.239319	0.000000	1736.239319	m
9 BM2 Energy with decimal part	694.267694	0.000000	694.267694	0.000000	694.267694	0.000000	694.267694	0.000000	694.267694	kWh
10 BM2 Volume (S) with decimal part	784136.666	0.000	784136.666	0.000	784136.666	0.000	784136.666	0.000	784136.666	x100 m
11 BM3 Original counter with decimal part	0.000	0.000	0.000	0.000	0.000	0.000	0.000	0.000	0.000	m
12 BM3 Volume (M) with decimal part	0.000000	0.000000	0.000000	0.000000	0.000000	0.000000	0.000000	0.000000	0.000000	x100 m
13 BM3 Corr. volume (M) with decimal part	0.000000	0.000000	0.000000	0.000000	0.000000	0.000000	0.000000	0.000000	0.000000	m
14 BM3 Energy with decimal part	0.000000	0.000000	0.000000	0.000000	0.000000	0.000000	0.000000	0.000000	0.000000	kWh
15 BM3 Volume (S) with decimal part	0.000	0.000	0.000	0.000	0.000	0.000	0.000	0.000	0.000	m
16 BM4 Original counter with decimal part	0.000	0.000	0.000	0.000	0.000	0.000	0.000	0.000	0.000	m
17 BM4 Volume (M) with decimal part	0.000000	0.000000	0.000000	0.000000	0.000000	0.000000	0.000000	0.000000	0.000000	m
18 BM4 Corr. volume (M) with decimal part	0.000000	0.000000	0.000000	0.000000	0.000000	0.000000	0.000000	0.000000	0.000000	m
19 BM4 Energy with decimal part	0.000000	0.000000	0.000000	0.000000	0.000000	0.000000	0.000000	0.000000	0.000000	kWh
20 BM4 Volume (S) with decimal part	0.000	0.000	0.000	0.000	0.000	0.000	0.000	0.000	0.000	x100 m
21 Flow rate at measured conditions (M)	0.00	0.00	0.00	0.00	0.00	0.00	0.00	0.00	0.00	m ³ /h
22 Corr. flow rate (M)	0.00	0.00	0.00	0.00	0.00	0.00	0.00	0.00	0.00	m ³ /h
23 Flow rate at basic conditions (B)	0.00	0.00	0.00	0.00	0.00	0.00	0.00	0.00	0.00	m ³ /h
24 Energy flow	0.0	0.0	0.0	0.0	0.0	0.0	0.0	0.0	0.0	kWh
25 Pressure	42.000		42.000		42.000		42.000		42.000	bar
26 Temperature	10.00		10.00		10.00		10.00		10.00	°C
27 Calorific value	11.294		11.294		11.294		11.294		11.294	kWh/m ³
28 Standard density	0.7511		0.7511		0.7511		0.7511		0.7511	kg/m ³
29 Conversion factor	44.0128		44.0128		44.0128		44.0128		44.0128	
30 K coefficient	0.90852		0.90852		0.90852		0.90852		0.90852	
31 Carbon dioxide	0.600		0.600		0.600		0.600		0.600	mol/h
32 Hydrogen	0.000		0.000		0.000		0.000		0.000	mol/h
33 Nitrogen	0.300		0.300		0.300		0.300		0.300	mol/h

Fig. 102: Menu page 8.40 Functional test results

No.	Name	Function
1	Print button	<ul style="list-style-type: none"> Print the results of the functional test, provided that a printer is available.
2	Export to CSV button	<ul style="list-style-type: none"> Export the results of the functional test to a file in CSV format.
3	Results of the functional test display	<ul style="list-style-type: none"> Display in table form of the results of the most recent functional test.

The results of the most recent functional test are shown here in table form.

- Press the corresponding button (fig. 102, no. 1 or no. 2) to print or export the results.

8.11 System settings

On the menu pages of chapter 9. System settings, basic settings can be made for the following system areas:

Menu page	Setting options
9.1 Software update	<ul style="list-style-type: none"> Upload software update file and run update (see section 8.11.1)
9.2 Time and date	<ul style="list-style-type: none"> Settings for time format, time zones and billing hour
9.3 Time synchronisation	<ul style="list-style-type: none"> Settings for time servers, connections to the time server and synchronisation scheduling
9.4 Memory management	<ul style="list-style-type: none"> Status display for the SD card, formatting the SD card
9.7 Serial interfaces	<ul style="list-style-type: none"> Settings for baud rate, mode, Modbus server register offset and Modbus server address offset, etc.
9.9 Firewall	<ul style="list-style-type: none"> Settings for ports
9.11 Ethernet 1	<ul style="list-style-type: none"> Settings for IP4, http, SSH, DHCP, route, gateway, etc.
9.12 Ethernet 2	<ul style="list-style-type: none"> Settings for IP4, http, SSH, DHCP, route, gateway, etc.
9.13 Ethernet 3	<ul style="list-style-type: none"> Settings for IP4, http, SSH, DHCP, route, gateway, etc.
9.14 Ethernet 4	<ul style="list-style-type: none"> Settings for IP4, http, SSH, DHCP, route, gateway, etc.
9.20 Modbus server	<ul style="list-style-type: none"> Settings for byte order, debug mode, ETH port, etc. Download the standard Modbus user list Upload a customised Modbus user list
9.25 DSfG status	<ul style="list-style-type: none"> Display various meters for executed DSfG transfers
9.30 DSfG	<ul style="list-style-type: none"> Define access codes 1 and 2 UI Enter names for archive groups 1 to 51
9.40 DSfG subscriber 1	<ul style="list-style-type: none"> Settings for DSfG connection addresses and subscribers
9.60 IOC	<ul style="list-style-type: none"> Activation of the IOC system
9.100 Access rights (only visible when a user is logged in or when the calibration switch is unlocked)	<ul style="list-style-type: none"> Allow software calibration switch, reset admin password, overwrite F-RAM
9.110 User management	<ul style="list-style-type: none"> Set admin authorisations
9.250 Software ID	<ul style="list-style-type: none"> Information page on the installed software version
9.400 HW / OS system info	<ul style="list-style-type: none"> Information page on the hardware / operating system
9.410 Screen / screensaver	<ul style="list-style-type: none"> Settings for screensaver, brightness, etc.
9.420 Device configuration	<ul style="list-style-type: none"> Download device configuration and import a device configuration
9.450 Device parameters	<ul style="list-style-type: none"> Settings for system language (see section 7.3.2), log level, serial number, device type and more Download system logs Download data book
9.500 System	<ul style="list-style-type: none"> Display system parameters

Table 30: Overview of the setting options in the System settings chapter

8.11.1 Software update

NOTE

Performing a software update

- ▶ A software update can only be performed when the calibration switch is unlocked, and only in the web view.
- ▶ Use only update files that you have received from RMG Messtechnik.
- ▶ Note that the power supply to the device must not be interrupted during a software update.

Proceed as follows to perform the software update:

- ▶ Navigate to the menu page **9.1 Software update**.

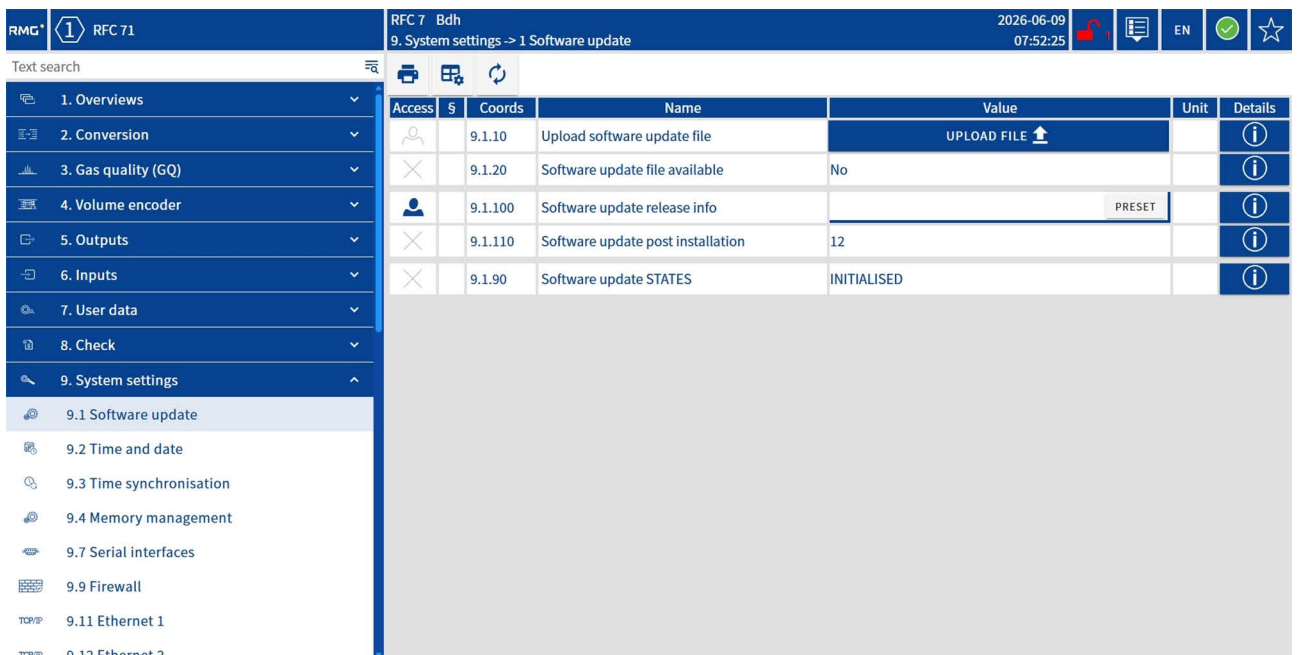

Fig. 103: Menu page 9.1 Software update

- ▶ Click on the **UPLOAD FILE** button.
 - ➔ A separate window opens (see fig. 104).



Fig. 104: Upload file window

- ▶ Tap or click on **Select file**.
 - ➔ A Windows Explorer window opens (see fig. 105)

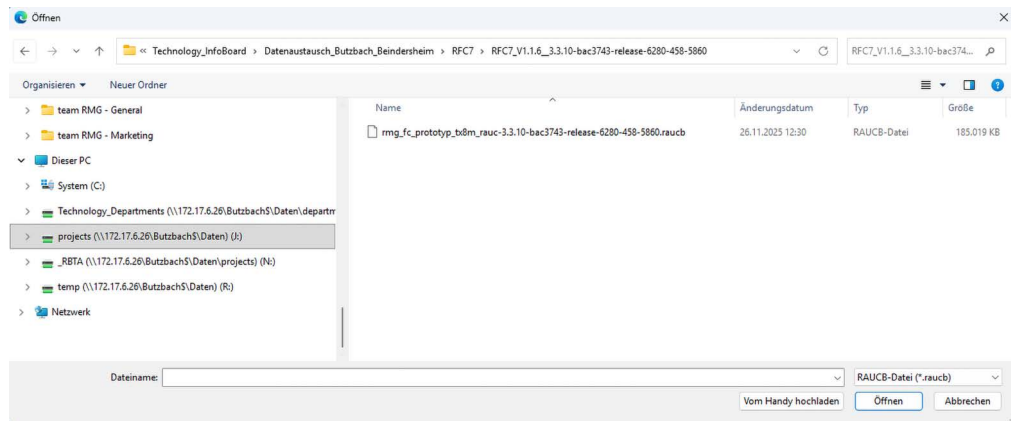

Fig. 105: Windows Explorer window

- ▶ Navigate to the directory that you have saved the software update file in, select it and click on the Open button.
- ➔ The selected file is shown in the **Upload file** window (see fig. 106)

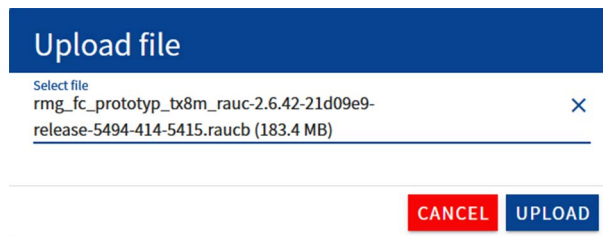

Fig. 106: Upload file window

- ▶ Click on the **UPLOAD** button.
- ➔ The selected file is uploaded. This can take several minutes (see fig. 107).

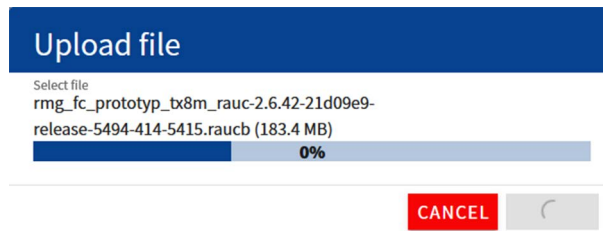

Fig. 107: Upload file window – progress bar

Once uploading is complete, additional coordinates are added to the menu page 9.1 Software update (see fig. 108).

Access	Coords	Name	Value	Unit	Details
	9.1.10	Upload software update file	UPLOAD FILE		
✗	9.1.20	Software update file available	Yes		
✗	9.1.30	Software update file size	189655709		
🔒	9.1.40	Start software update	No		
	9.1.50	Cancel software update	No		
✗	9.1.60	Software update message	Hochgeladene Datei=</tmp/upload_update.raucb> ist bereit		
✗	9.1.70	Software update progress	-1	%	
🔒	9.1.80	Complete / restart software update	No		
	9.1.100	Software update release info	<input type="text" value="PRESET"/>		
✗	9.1.110	Software update post installation	12		
✗	9.1.90	Software update STATES	WAIT FOR UPDATE START		

Fig. 108: Menu page 9.1 Software update after the software update file has been uploaded

- ▶ At the dropdown menu of coordinate **9.1.40 Start software update**, select the setting **Yes**.
- ▶ At the dropdown menu of coordinate **9.1.80 Complete / restart software update**, select the setting **Yes**.
- ▶ Save your settings by clicking on the corresponding button.
 - ➔ The software update starts. Once the update is complete, the device re-starts and the installed software version is shown in the header (web view) or footer (touchscreen).



8.11.2 Formatting the SD card

The SD card can only be formatted when the calibration switch is unlocked.

Proceed as follows to carry out formatting:

- ▶ Navigate to the menu page **9.4 Memory management**.

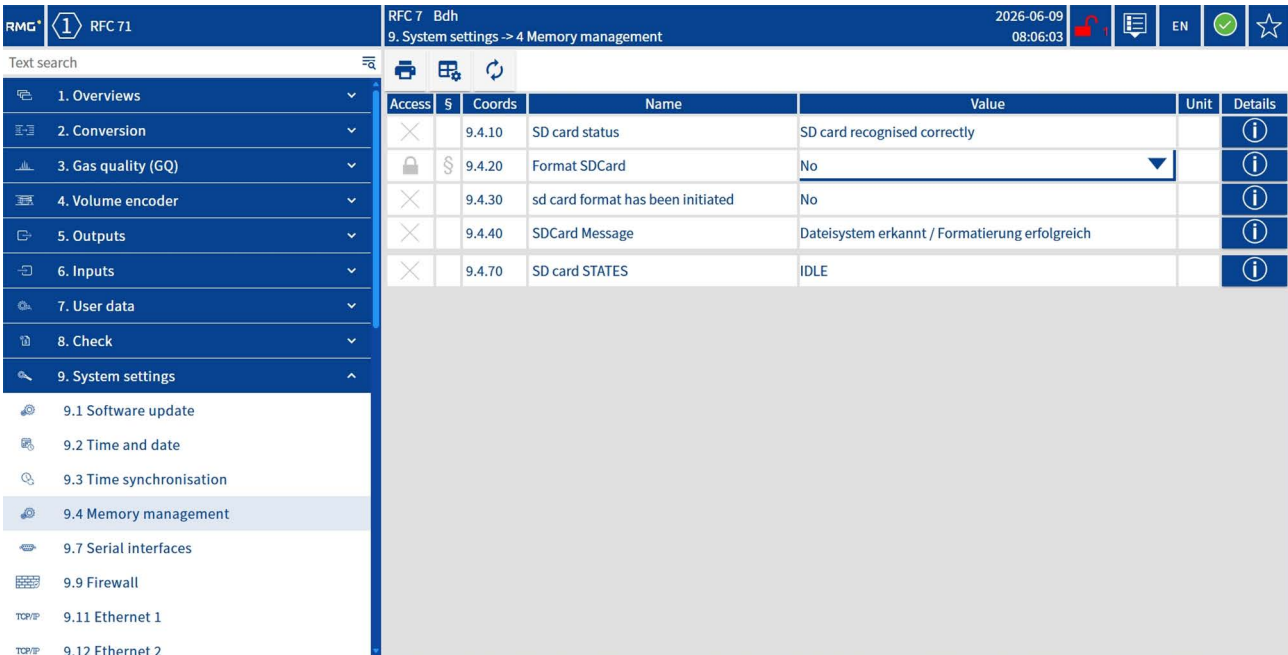

Fig. 109: Menu page 9.4 Memory management



- ▶ At coordinate **9.4.20 Format SD card**, select the setting **Yes** and save it.
- ➔ The SD card is formatted the next time the device is restarted.

8.11.3 Customising the Modbus user list

The Flow Computer RFC 7 is delivered with a register-based standard Modbus user list. Please proceed as follows to download or, if necessary, customise the standard Modbus user list:

- ▶ Navigate to the menu page **9.20 Modbus server** (see fig. 110).

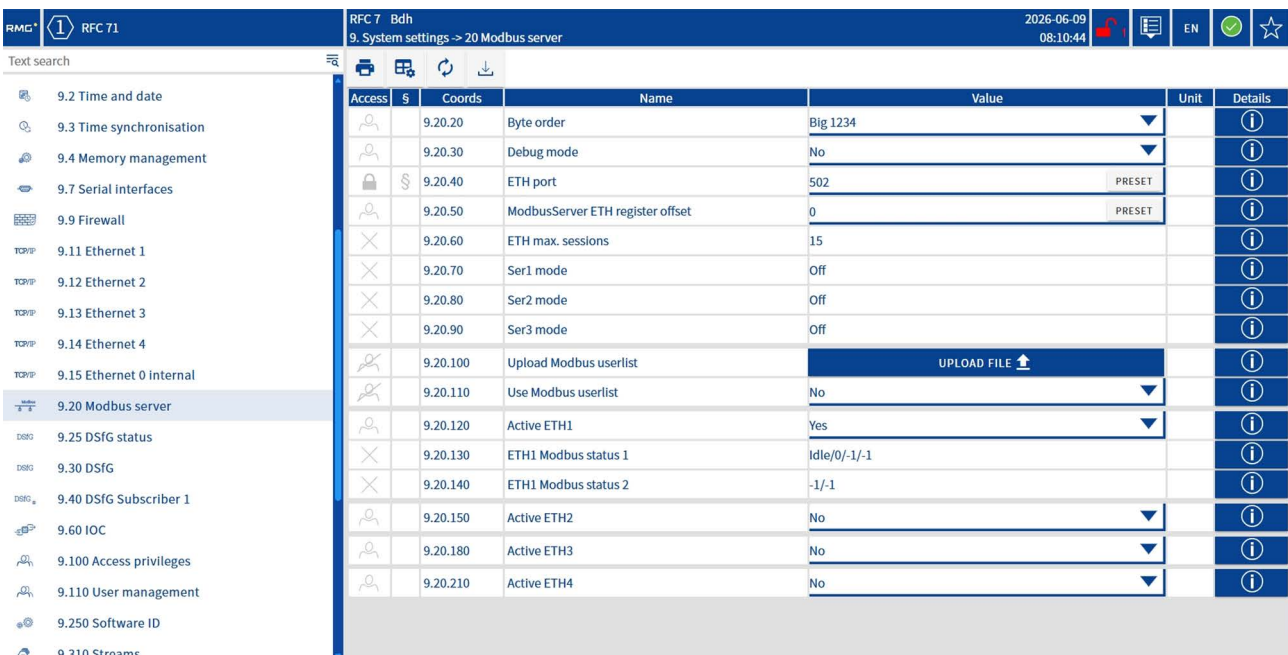

Fig. 110: Menu page 9.20 Modbus server



- ▶ Download the standard Modbus user list by clicking on the **Download Modbus standard** button and save the downloaded CSV file on your PC in a directory of your choosing.

NOTE

Customising the Modbus user list

- ▶ Please contact RMG Messtechnik GmbH to customise the Modbus user list.
- ▶ Click on the **UPLOAD FILE** button to upload the customised Modbus user list.
 - ➔ A separate window opens (see fig. 111).



Fig. 111: Upload file window

- ▶ Tap or click on **Select file**.
 - ➔ A Windows Explorer window opens.
- ▶ Navigate to the directory that you have saved the CSV file with the Modbus user list customised by RMG in, select it and click on the Open button.
 - ➔ The selected file is shown in the **Upload file** window (see fig. 112)

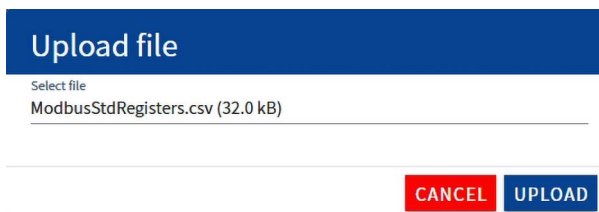

Fig. 112: Upload file window

- ▶ Click on the **UPLOAD** button.
- ▶ The selected file is uploaded. This can take several minutes.
- ▶ To actually apply the uploaded file, select the setting **Yes** at coordinate **9.20.110 Use Modbus user list** and save it.
 - ➔ The uploaded customised Modbus user list is now in use.



8.11.4 DSfG settings

DSfG (Digitale Schnittstelle für Gasmessgeräte, Digital Interface for Gas Metering Devices) is, in simplified terms, split into two main connection types:

- **DSfG-A:** An interface over RS485 (Ser1 to Ser3), used between different measuring devices to transfer data.
- **DSfG-B:** An interface over Ethernet (ETH1 to ETH4) that communicates between a measuring device and a data retrieval centre (e.g. RDT).

Both interfaces have access to the same values and can read and write. Write access is, however, restricted to a few elements and almost always requires the access codes from the menu **9.30 DSfG**.

The following menu pages provide an overview and settings for data exchange over DSfG:

- 9.25 DSfG status
- 9.30 DSfG
- 9.40 DSfG subscriber 1

Menu 9.25 DSfG status

Access	s	Coords	Name	Value	Unit	Details
×		9.25.10	Count err telegram out queue full	0		i
×		9.25.20	Count err telegram receive abort	0		i
×		9.25.30	Count err telegram send abort	0		i
×		9.25.40	Count err send block	0		i
×		9.25.50	Count err wrong Bcc	0		i
×		9.25.60	Count received blocks	0		i
×		9.25.70	Count received telegrams	0		i
×		9.25.80	Count send blocks	0		i
×		9.25.90	Count Dno sender mismatch	0		i
×		9.25.100	DSfG subscriber 1			i
×		9.25.110	Last transfer	0		i
×		9.25.120	Activity	0		i

Fig. 113: Menu page 9.25 DSfG status

The menu page **9.25 DSfG status** provides an overview of the DSfG connections. The following information can be found on the menu page:

- At coordinates **9.25.10** to **9.25.90**, the messages sent and any errors that have occurred are counted.
- Coordinate **9.25.100** shows all addresses currently detected on the DSfG-A bus.
- Coordinates **9.25.110** and **.120** indicate when and whether transmissions have taken place over the DSfG-A bus.

Menu 9.30 DSfG

Access	S	Coords	Name	Value	Unit	Details
		9.30.30	UI access code 1	9999 PRESET		
		9.30.40	UI access code 2	9999 PRESET		
		9.30.50	DSfG access code 1			
		9.30.60	DSfG access code 2			
		9.30.70	User lock	Closed		
		9.30.80	Tid	1		
		9.30.90	AG1 name	AG1 PRESET		
		9.30.100	AG1 number of channels	13		
		9.30.110	AG1 to AG4 + AG13 - standard archives fill level from	1		
		9.30.120	AG1 to AG4 + AG13 - standard archives fill level to	4		
		9.30.130	AG1 to AG4 + AG13 - standard archives fill level for service request	999999999 PRESET		
		9.30.140	AG2 name	AG2 PRESET		
		9.30.150	AG2 number of channels	10		
		9.30.160	AG3 name	AG3 PRESET		
		9.30.170	AG3 number of channels	13		
		9.30.180	AG4 name	AG4 PRESET		
		9.30.190	AG4 number of channels	10		
		9.30.200	AG9 name	AG9 PRESET		
		9.30.210	AG9 number of channels	4		
		9.30.220	AG9 fill level from	1		
		9.30.230	AG9 fill level to	2		

Fig. 114: Menu page 9.30 DSfG

In the menu **9.30 DSfG**, settings that apply to the entire device and that are required, among other things, for reading out the archives over the DSfG-B bus are made:

- ▶ Some values may only be written over DSfG when access codes are supplied with them. At coordinates **9.30.30** and **9.30.40 UI Access code 1/2**, the access codes (a kind of password) expected by the device are entered.
- At coordinates **9.30.50** and **9.30.60 DSfG access code 1/2**, the values are set over DSfG when corresponding write access takes place. The values for **access code 1 (9.30.30 and 9.30.50)** and **access code 2 (9.30.40 and 9.30.60)** must match for write access to be accepted.
 - ➔ If the access codes are correct, the **user lock** at coordinate **9.30.70** opens to allow write access.
 - ➔ The values at coordinates **9.30.50 and .60 DSfG Access code 1/2** are then reset. (Because of this reset, the user sees these access codes only very briefly, or not at all.)
- Coordinate **9.30.80 TID** is the data exchange reference, i.e. the telegrams sent are numbered in sequence so that responses can be correctly assigned.
- ▶ The remaining coordinates in this menu follow the same structure, explained here using archive group 1 (AG1) as an example:
 - **9.30.90 AG1 Name:** A name for the archive group can be entered here.
 - **9.30.100 AG1 Number of channels:** Indicates how many columns are in the archive.
 - **9.30.110/120 AG1 to AG4 + AG13 – Standard archives Fill level from/to:** Refers to the number of entries (sequence numbers) in the relevant archive.

- 9.30.130 AG1 to AG4 + AG13 – Standard archives **Fill level for service request**: Describes which entry a service request is triggered from. When a service request is triggered, a warning message is issued. It indicates that the archive is becoming too full.

NOTE

Archive groups AG1 to AG4 and AG13

The following archive groups are the standard archive groups:

- AG1: Meters and measured values for billing mode 1
- AG2: Fault counter for billing mode 1
- AG3: Meters and measured values for billing mode 2
- AG4: Fault counter for billing mode 2
- AG13: Meter for undefined billing mode

The archive groups listed share coordinates **9.30.110 to .130**, since the same values always apply to these archives.

Menu 9.40 DSfG subscriber 1

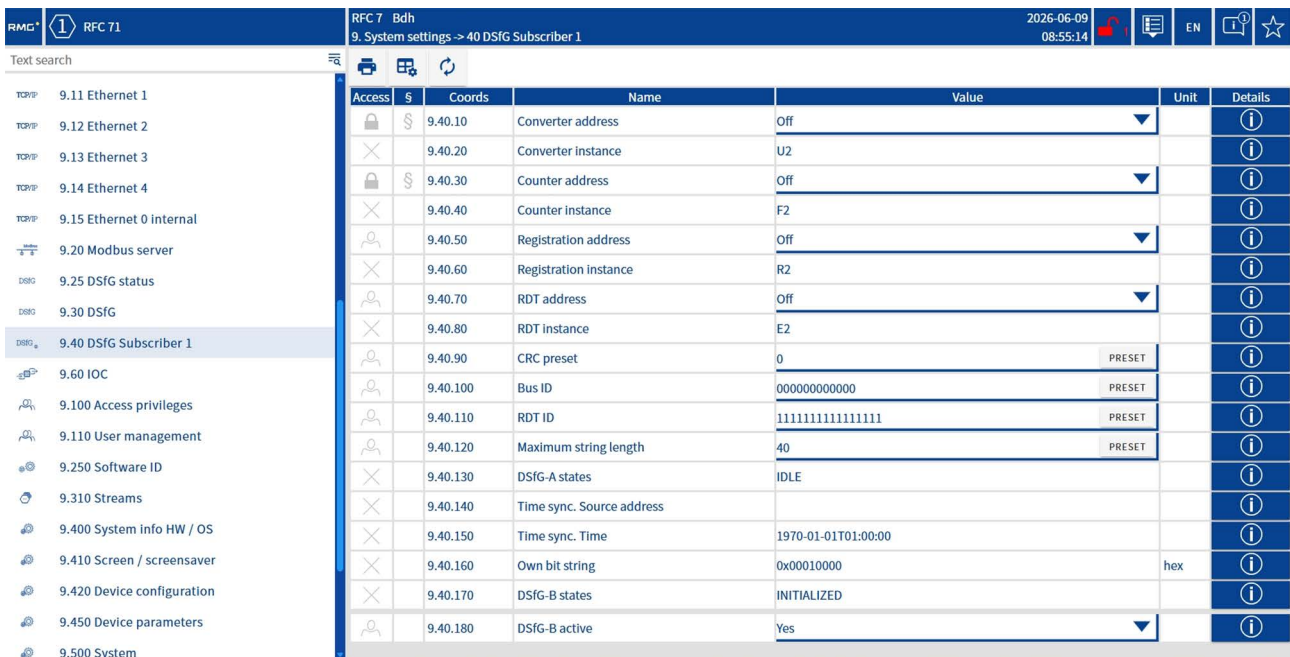

Fig. 115: Menu page 9.40 DSfG subscriber 1

In the menu **9.40 DSfG subscriber 1**, settings are made for an individual DSfG subscriber. (Note: The RFC 7 has only one subscriber.)

- The addresses for the DSfG instances available in the device can be chosen freely in principle, but they must not be assigned twice within a DSfG bus.
 - ➔ The detected addresses are shown at coordinate **9.25.100 DSfG subscriber 1**.
- ▶ Set the addresses at the following coordinates:
 - **9.40.10 Volume converter address**
 - **9.40.30 Meter address**
 - **9.40.50 Registration address**

- **9.40.70 RDT address**
- The following coordinates indicate how the relevant instance identifies itself to other devices:
 - **9.40.20 Volume converter instance**
 - **9.40.40 Meter instance**
 - **9.40.60 Registration instance**
 - **9.40.80 RDT instance**
- ▶ At coordinate **9.40.90 CRC preset**, set a default value as the preset for calculating the CRC checksum at the end of a telegram.
- ▶ At coordinate **9.40.100**, specify the **bus ID**. This is used in the login procedure for DSfG-B and describes the DSfG bus that the device is connected to.
- ▶ At coordinate **9.40.110**, specify the **RDT ID**. The RDT ID is also used in the login procedure for DSfG-B and is a kind of password for logging in.
- ▶ At coordinate **9.40.120**, specify the **maximum string length**. This determines the maximum number of characters that strings (texts) sent over DSfG may have. Longer texts are truncated. The DSfG standard is 40 characters, although the RFC 7 can also send more characters without difficulty.
- ▶ Allow data transfer over DSfG-B by selecting the setting **Yes** at coordinate **9.40.180 DSfG-B active**.
- ▶ Also check at coordinate **9.9.130 DSfG-B IP** in the menu **9.9 Firewall** whether the correct port is entered.

8.11.5 Downloading / importing the device configuration

When a user is logged in, the Flow Computer RFC 7 offers the following options for handling the device configuration:

- Download the device configuration and back it up to an XML file.
- Edit the device configuration in the XML file.
- Import the edited device configuration from an XML file.

NOTE

Importing the device configuration

The import of a device configuration can be used when the configuration is to be replicated from one device to another. The following conditions must be met to carry out such an import:

- ▶ An administrator with the corresponding password must be logged in.
- ▶ The hardware calibration switch must be unlocked.

Procedure for downloading the device configuration:

- ▶ Navigate to the menu page **9.420 Device configuration**.

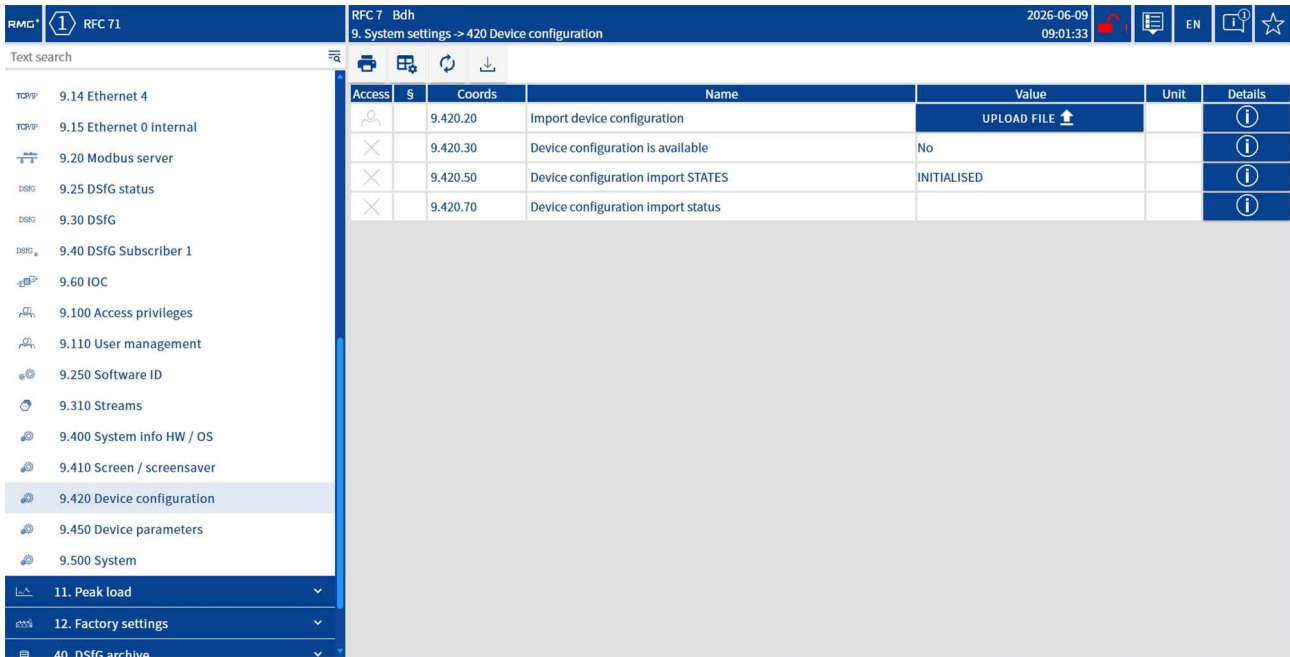

Fig. 116: Menu page 9.420 Device configuration



- ▶ Download the current device configuration by clicking on the **Download device configuration** button and save the downloaded XML file on your PC in a directory of your choosing.
- ▶ Edit the device configuration in the XML file according to your requirements and save your changes.

Procedure for importing the device configuration

- ▶ If you have not already done so, navigate to the menu page **9.420 Device configuration**.
- ▶ Click on the **UPLOAD FILE** button (fig. 116, no. 2).
 - ➔ A separate window opens (see fig. 117).



Fig. 117: Upload file window

- ▶ Tap or click on **Select file**.
 - ➔ A Windows Explorer window opens (see fig. 118)

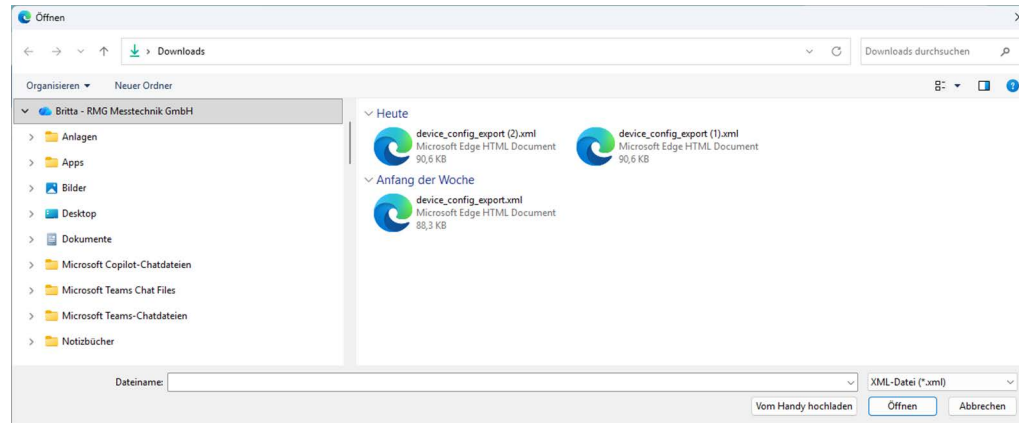

Fig. 118: Windows Explorer window

- ▶ Navigate to the directory that you have saved the XML file with the device configuration in, select it and click on the Open button.
 - ➔ The selected file is shown in the **Upload file** window (see fig. 119)



Fig. 119: Upload file window

- ▶ Click on the **UPLOAD** button.
 - ➔ The selected file is uploaded. This can take several minutes. Once uploading is complete, additional coordinates are added to the menu page 9.420 Device configuration (see fig. 120).

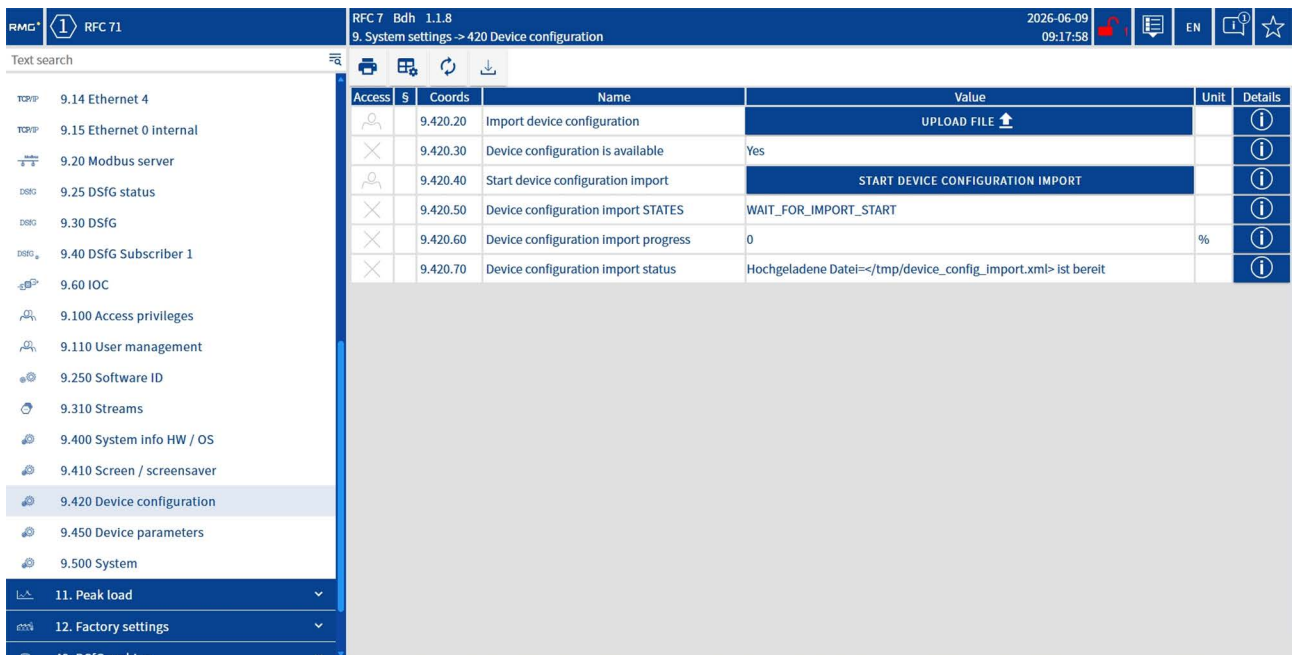

Fig. 120: Menu page 9.420 Device configuration after the XML file has been uploaded

- ▶ Click on the **START DEVICE CONFIGURATION IMPORT** button.
 - ➔ The device configuration from the selected XML file is imported into the device.
 - ➔ When coordinate **9.420.60 Device configuration import progress** shows the value **100%**, the import is complete.

9 Operation

Once the RFC 7 has been commissioned, it runs without interruption.

Observe the following instructions to ensure faultless operation:

- Read this operating manual carefully to avoid incorrect operation and only use the RFC 7 as intended (see section 2.1 "Intended use").
- Only operate the RFC 7 within the performance limits specified in the technical data (see section 13 "Technical data"), and do not exceed them.
- Protect the device from sources of heat (e.g. direct sunlight).
- Take any damaged or unsafe device out of circulation immediately and label it accordingly to prevent inadvertent reuse.
- Have any defective device repaired only by RMG Messtechnik GmbH.

9.1 Maximum load display and registration

The maximum load display and registration is a fiscal function module within the RFC 7 Flow Computer and is identified by its own rating plate (see fig. 2 in section 2.5.2 "Nameplate, stream").

It continuously monitors the volumes at base conditions determined per hour and per day and compares them with a previously recorded value for the same observation period (hour or day).

The current values for the started and most recently completed observation periods, together with the current peak values and the timestamp of a completed observation period, are shown on the following menu pages (peak load display):

- 11.10 Max. hour / day and month
- 11.20 Max. day / month

Access	Coords	Name	Value	Unit	Details
11.10.10	§	Standard volume (current hour)	0.000000	x100 m3	i
11.10.20	§	Standard volume (previous completed hour)	0.000000	x100 m3	i
11.10.30	§	Last hour was valid	Yes		i
11.10.60	§	Standard volume (peak hour of the current gas day)	0.000000	x100 m3	i
11.10.70	§	Standard volume (peak hour of the current gas month)	0.000000	x100 m3	i
11.10.80	§	Peak hour of the current gas day timestamp	1970-01-01T01:00:00		i
11.10.100	§	Peak hour of the current gas month timestamp	1970-01-01T01:00:00		i
11.10.120	§	Standard volume (peak hour of the last gas day)	0.000000	x100 m3	i
11.10.130	§	Standard volume (peak hour of the last gas month)	0.000000	x100 m3	i
11.10.140	§	Peak hour of the last gas day timestamp	1970-01-01T01:00:00		i
11.10.160	§	Peak hour of the last gas month timestamp	1970-01-01T01:00:00		i
11.10.180	§	Start of gas day	2026-06-09T06:00:00		i
11.10.190	§	Start of gas month	2026-06-01T06:00:00		i

Fig. 121: Menu page 11.10 Max. hour / day and month (sample display of peak values)

NOTE**Start of a gas day**

A gas day does not necessarily start at 00:00. A different start time can be set in the menu **9.2 Time and date**.

- ▶ At coordinate **9.2.170 Billing hour**, set a time for the start of the gas day. The default setting is 06:00, i.e. each day ends at 06:00 and a new entry is made at this time at coordinate 11.20.20 Volume at base conditions for last completed gas day.
- ▶ If the RFC 7 is used in a time zone where the time switches between summer time and winter time (e.g. in Germany), the start of the gas day must not coincide with the official changeover time (02:00 and 03:00).

Coordinates **11.10.30** and **11.20.30** indicate whether the peak value determination for the **last completed hour** or the **last completed gas day** was valid.

Following changes to the system time, e.g. due to manual adjustments or after a power failure, the new time may no longer correspond to a valid hour or day rollover. The following criteria are used to check whether the determination is nevertheless valid:

For a valid hour rollover, the number of seconds elapsed in the last hour is checked.

- An hour has 3,600 seconds.
- Tolerance: $\pm 1\%$ corresponds to ± 36 s.

The hour is deemed **valid** if $3,600 - 36 < \text{duration of the last hour} < 3,600 + 36$.

The hour is deemed **invalid** if the duration is outside of this range.

For a valid day rollover, the number of seconds elapsed in the last day is checked.

- A full day has 86,400 seconds.
- Tolerance: $\pm 1\%$ corresponds to ± 864 s.

The day is deemed **valid** if $86,400 - 864 < \text{duration of the last day} < 86,400 + 864$.

The day is deemed **invalid** if the duration is outside of this range.

If a current value exceeds the stored comparison value, it is buffered as the new peak value and shown on the menu pages mentioned above. When the day or month changes, the peak values are stored in the archives of the RFC 7 Flow Computer (peak load registration). The archives can be viewed on the following menu pages:

- 40.220 'AG 22 – Peak load for gas day': Registration of the largest hourly volume over the course of the gas day.
- 40.230 'AG 23 – Peak load for gas month': Registration of the largest hourly volume and the largest daily volume over the course of the gas month.

Registration in AG 23 – Peak load for gas month takes place on the first day of the month at the defined start of the gas day.

Data acquisition and storage in archives AG 22 and AG 23 is independent of data acquisition in the other archive groups (see section 9.2 "Data storage in DSfG archives").

9.2 Data storage in DSfG archives

The screenshot shows the RMG software interface. At the top, there is a header bar with 'RFC 7 Bdh', '2026-06-09 11:13:44', and 'EN'. Below the header, there is a search bar and a list of menu items. The '40. DSfG archive' menu is expanded, showing a list of archive groups. The '40.10 AG 1 - BM1 counter + measured values' menu item is selected, and its corresponding data table is displayed on the right.

Timestamp	Ordinal number	CRC OK	§ BM1 / Operating volume baal / caafd / caqfd m3	§ BM1 / Operating volume with decimal part baaj / caagd / caqgd	§ BM1 / Corrected operating volume baae / caahd / caqhd m3	§ BM1 baaf / d m3
2026-06-09T11:00:00	7	Ok	46932	0.545001	46921	0.3316f
2026-06-09T10:00:00	6	Ok	46932	0.545001	46921	0.3316f
2026-06-09T09:00:00	5	Ok	46932	0.545001	46921	0.3316f
2026-06-09T08:00:00	4	Ok	46932	0.545001	46921	0.3316f
2026-06-09T07:51:35	3	Ok	46932	0.545001	46921	0.3316f
2026-06-09T07:51:21	2	Ok	46932	0.545001	46921	0.3316f
2026-06-09T07:51:21	1	Ok	46932	0.545001	46921	0.3316f

Fig. 122: Menu page 40.10 AG 1 – BM1 counter and measured values

During operation, the RFC 7 stores the measured data acquired in what are known as DSfG archives. In accordance with the requirements set out in DVGW Information Gas No. 7 for DSfG, the measured data is assigned to the different archive groups and can be viewed on the menu pages listed below (AG = archive group, BM = billing mode):

Standard archives:

- 40.10 AG 1 – BM1 meter + measured values
- 40.20 AG 2 – BM1 fault counter
- 40.30 AG 2 – BM2 meter + measured values
- 40.40 AG 4 – BM2 fault counter
- 40.130 AG 13 – Counter for undefined BM

Instance F archives:

- 40.90 AG 9 – Instance F 1b
- 40.100 AG 10 – Instance F 2a
- 40.110 AG 11 – Instance F 2b+c

Gas quality:

- 40.120 AG 12 – Gas quality

Functional test:

- 40.170 AG 17 – Functional test part 1
- 40.180 AG 18 – Functional test part 1
- 40.190 AG 19 – Functional test part 1

Peak load display:

- 40.220 AG 22 – Peak load for gas day
- 40.230 AG 23 – Peak load for gas month

Logbook:

- 40.210 AG 21 – Logbook
- 40.500 AG 50 – Official calibration logbook
- 40.510 AG 51 – Unofficial calibration logbook



Each archive can be downloaded by clicking on the **Download** button. The data is saved as a .csv file.

NOTE

Archive depth

Each archive stores a maximum of 8,000 entries. Once the capacity is exceeded, the oldest entries are deleted automatically.

9.3 Deleting archives

The measured data in the individual archive groups can be deleted as follows, in accordance with the access authorisations (visible in the Access column):

- ▶ Navigate to the menu page **12.20 Deletion processes**.

Access	Coords	Name	Value	Unit	Details
🔒	12.20.10	Delete standard archives AG1 to AG4 + AG13	No		ⓘ
🔒	12.20.20	Delete AG 9 – Modbus client for USM 1b	No		ⓘ
🔒	12.20.30	Delete AG 10 – Modbus client for USM 2a	No		ⓘ
🔒	12.20.40	Delete AG 11 – Modbus client for USM 2b+c	No		ⓘ
🔒	12.20.50	Delete AG 12 – Gas quality	No		ⓘ
👤	12.20.60	Delete AG17 – functional test part 1	No		ⓘ
👤	12.20.70	Delete AG18 – functional test part 2	No		ⓘ
👤	12.20.80	Delete AG19 – functional test part 3	No		ⓘ
🔒	12.20.90	Delete AG21 – logbook	No		ⓘ
🔒	12.20.100	Delete AG22 – peak load gas day	No		ⓘ
🔒	12.20.110	Delete AG23 – peak load gas month	No		ⓘ
🔒	12.20.120	Delete AG50 – official calibration logbook	No		ⓘ
🔒	12.20.130	Delete AG51 – non-official calibration logbook	No		ⓘ
👤	12.20.140	Delete drag indicator	No		ⓘ

Fig. 123: Menu page 12.20 Deletion processes

- ▶ At the coordinate of the archive to be deleted (e.g. 12.20.60 AG 17 – Delete functional test part 1), select the setting **Yes** and save it, if you are operating in the web view with a PC.
 - ➔ The archive is deleted.

10 Maintenance and regular checks

⚠ DANGER

Danger of death arising from electrical voltage

Before servicing, maintenance and cleaning work, it is essential to switch off the device and disconnect it from the mains power supply. Failing to do so may lead to extremely severe injury or death.

- ▶ Before any work is commenced, switch off the device's power supply and disconnect it from the mains.
- ▶ Only carry out work on the device as described in this manual. Ensure that the device is not live while the work is being performed.

⚠ DANGER

Danger of death arising from the device being damaged during maintenance and cleaning work

If the device is damaged because unsuitable tools were used or because cleaning was performed incorrectly, this may result in danger of death.

- ▶ Only use suitable tools to prevent damage to components.
- ▶ Only clean the device with a slightly damp cloth to avoid static charging of the housing.

⚠ DANGER

Danger of death arising from operating a defective device

If a defective, damaged or unsafe device is used after servicing, maintenance and cleaning work, this may result in danger of death.

- ▶ If a device is damaged or unsafe, it must be removed from circulation immediately and labelled accordingly to prevent it from being used accidentally.
- ▶ Ensure that the defective device is only repaired by RMG Messtechnik GmbH.

NOTE

Maintenance and repair work

In the case of normal use of the RFC 7, the device does not require regular maintenance.

- ▶ For more information, please contact RMG.
- ▶ Only have repairs performed by RMG, in order to avoid voiding guarantee claims as the result of incorrect repair work.

11 Potential errors and repairs

11.1 Error messages

The error messages are categorised as follows:

- E – alarms (error): Measurement error
- W – warnings: Error relating to functions
- H – information: Messages without errors

Some messages are listed as alarms and warnings. The corresponding limits can be set by means of 'administrator' access rights for warnings and only by means of the calibration lock for alarms.

11.2 Repairs

For spare parts and repairs, please contact our 'Repairs & Spares' department at:

Phone: +49 6033 897–897

Email: repairs-spares@rmg.com

12 Dismantling and disposal

⚠ DANGER

Danger of death arising from electrical voltage

Before dismantling work, it is essential to switch off the device or disconnect it from the mains power supply. Failing to do so may lead to extremely severe injury or death.

- ▶ Before any work is commenced, switch of the device’s power supply or disconnect it from the mains.
- ▶ Only carry out work on the device as described in this manual. Ensure that the device is not live while the work is being performed.

12.1 Dismantling

To dismantle the Flow Computer RFC 7, please proceed as follows:

1. Remove all data saved on the device by erasing all archives. To do this, navigate to menu 12. Factory settings. If you have the corresponding access rights, you can then erase the archive and reset the counters.
2. De-energise the device.
3. Loosen the device’s fastening screws and carefully pull it forwards out of the rack.
4. Disconnect the connection cables.
5. Remove the device from the switch cabinet entirely.

12.2 Disposal

Dispose of device components and packaging material in an environmentally sound manner in accordance with the applicable waste management and national waste disposal regulations and standards of the region or country to which the device is delivered.

Within the EU, the following applies:

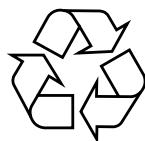

In accordance with EU Directive 2012/19/EU / the German Electrical and Electronic Equipment Act (ElektroG), devices that are no longer needed must be taken to recycling station.



The device must not be disposed of with household waste!

13 Technical data

Design	
Device variants	<ul style="list-style-type: none"> ■ Single-Stream (one stream – data from one measurement point are processed by the RFC 7) ■ Multi-Stream (two to four streams – data from up to four measurement points are processed in the RFC 7) <p>(Please note: the Multi-Stream variant is not currently available!)</p>
Housing variants	<ul style="list-style-type: none"> ■ 19" housing for 1–2 streams, Dimensions: 213.36 mm (42 HP) x 133.35 mm (3 RU) x 230 mm (W x H x D) (without connector on the back) ■ 19" housing for 3–4 streams 426.72 mm (84 HP) x 133.35 mm (3 RU) x 230 mm (W x H x D) (without connector on the back)
Weight	<ul style="list-style-type: none"> ■ 1 stream: 1.75 kg ■ 2 streams: 2.25 kg
Material	FR4 (front panel) and aluminium (housing)
Protection class	IP 20 (protection from solid bodies >12.5 mm, not splash-proof)
Components in the housing	<ul style="list-style-type: none"> ■ Power pack 24 V DC ■ Intercom (for Multi-Stream variants) <p>Additionally five plug-in circuit boards per stream:</p> <ul style="list-style-type: none"> ■ CoM-Basis for communication and computing ■ IO-System for time-critical communication with actuators and sensors, comprising: <ul style="list-style-type: none"> - IOC-EX-IO as interface to Ex zone with securely separated inputs - IOC-Digital-IO as interface for digital inputs and outputs outside of the Ex zone - IOC-CPU to process all analogue and digital inputs and outputs - IOC-Analog-Out as interface for analogue outputs outside of the Ex zone <p>With these plug-in circuit boards, all the intended functions can be executed. The hardware is not designed for expansion with plug-in circuit boards for additional functions.</p>
Field of application	
Ambient, operating and storage temperature	-20 to 50 °C
Humidity class	EN12405-3 SL1 internal 85% non-condensing
EMC class	Class A (radiated interference field strength) Class B (EN 55032)
Explosion protection	The device is not intended for use in potentially explosive atmospheres! Nevertheless, devices and sensors may be connected to the Ex inputs and outputs of the RFC 7 that are located in a potentially explosive atmosphere (Ex Zone 1).

Approvals in acc. with	
EU Directives	<ul style="list-style-type: none"> ■ Measurement Instruments Directive 2014/32/EU ■ EMC Directive 2014/30/EU ■ RoHS Directive 2011/65/EU
EX approvals	Interface for devices in Ex Zone 1: <ul style="list-style-type: none"> ■ ATEX Directive 2014/34/EU ■ IECEX
National laws and ordinances	<ul style="list-style-type: none"> ■ German Weights and Measures Act (MessEG) – dated 25 July 2013 ■ German Weights and Measures Ordinance (MessEV) – dated 11 Dec. 2014
Calculation methods of compressibility coefficient K	
Available methods	<ul style="list-style-type: none"> ■ k = constant ■ Complete analysis: <ul style="list-style-type: none"> - AGA 8 DC92 - AGA 8:2017 - GERG-2004 - GERG-2008 ■ Gross values: <ul style="list-style-type: none"> - GERG-88 S - GERG-88 S Set B - GERG-88 S Set C - AGA NX-19 L - AGA NX-19 H - AGA Gross Meth. 1 - AGA Gross Meth. 2 - SGERG-mod-H2 ■ Pure substances: <ul style="list-style-type: none"> - Van der Waals - Beattie & Bridgeman
Operation	
From front panel:	
Display	7" touchscreen Active area of the touchscreen 154.2 x 85.92 mm (W x H) 1024 x 600 pixels
LEDs	<ul style="list-style-type: none"> ■ Alarm/error/fault (red) ■ Warning (yellow) ■ Measurement (green) ■ Power supply on (blue)
Calibration switch	<ul style="list-style-type: none"> ■ Can be moved up and down with additional tool ■ Lead-sealed for applications involving official calibration
Software	Integrated GUI
From PC or local network:	
Connection to Ethernet port	<ul style="list-style-type: none"> ■ Connect network cable to Eth 1, 2, 3 or 4 ■ Enter IP address of the RFC 7 in address bar (URL bar)
Software	Integrated web UI
Available languages	German, English, Chinese

Technical data	
Power supply	24 V DC +10%/-15%
Current consumption	0.8 A, typical for 1 stream
Power consumption	Max. 20 W
Fuse	2 A slow-blow (Single-Stream)
System hardware version	
System controller (CoM-Basis)	
Processor	Quad Core ARM Cortex®-A53 based NXP: i.MX8M mini
CPU speed	Up to 1.6 GHz
On-board operating system	Linux
Real-time clock	Battery-buffered
Watchdog timer	Yes
Safety function	Integrated firewall
Memory	2 GB SDRam working memory 4 GB eMMC program (permanent) memory
Serial interfaces (2x per stream, 1x optional)	
SER 1 (RJ45)	RS 485
SER 2 (RJ45)	RS 485
(SER 3 optionally via adapter)	(RS 485 optional)
Available communication protocols	<ul style="list-style-type: none"> ■ Modbus RTU client/server ■ Modbus ASCII client/server ■ Modbus client for USM (F instance) ■ Modbus client for gas quality
Baud rate	9600–115,200 depending on communication protocol
Data interfaces (Ethernet 4 x per stream)	
Eth 1	RJ45
Eth 2	RJ45
Eth 3	RJ45
Eth 4	RJ45
Available communication protocols	<ul style="list-style-type: none"> ■ Modbus TCP/IP ■ http ■ SNMP
IO controller IOC	
Microcontroller	STM32F429, ARM-Cortex M4
CPU speed	100 MHz
Memory	1 MB flash
Digital inputs per stream	
Quantity	4x status inputs, optically isolated: <ul style="list-style-type: none"> ■ DI1–DI4
U _{max}	5 V
I _{max}	15 mA
f _{max}	2 Hz

Digital outputs per stream	
Quantity	6x digital outputs: <ul style="list-style-type: none"> ■ DO1–DO2: Digital/frequency output with max. 5 kHz ■ DO3–DO6: Digital/pulse output with 500 Hz (min. pulse width 1 ms)
U_{\max}	24 VDC +10%
I_{\max}	20 mA
Analogue inputs per stream	
Quantity	5x analogue inputs, securely separated: <ul style="list-style-type: none"> ■ AI1–AI2: Analogue input with HART interface ■ AI3: Analogue input ■ AI4–AI5: Analogue input with intrinsically safe design with HART interface <ul style="list-style-type: none"> - Ex limits must be observed without fail! - Recommended for pressure and temperature measurement.
Range	4–20 mA
Resolution	24 bit ADC
U_{\max}	22 V
I_{\max}	21 mA
Measurement time	~ 500 ms
Measurement rate	2 Hz
Analogue outputs per stream	
Quantity	4x analogue outputs: <ul style="list-style-type: none"> ■ AO1–AO4: Analogue output
Range	4–20 mA
Resolution	PWM 14 bit
Pulse inputs per stream	
Quantity	<ul style="list-style-type: none"> ■ 2x pulse inputs (PI1 and PI2) in intrinsically safe design, <ul style="list-style-type: none"> - Ex limits must be observed without fail - N1–N2: for reed (LF) or Namur (HF) ■ 1x encoder input in intrinsically safe design, <ul style="list-style-type: none"> - Ex limits must be observed without fail - N3 ■ 2x pulse inputs (PI3 and PI4) not intrinsically safe in open-collector design <ul style="list-style-type: none"> - DI1 and DI2
Measuring range	<ul style="list-style-type: none"> ■ Reed: 0–5 Hz ■ Namur: 0–5 kHz ■ OC: 0–5 kHz
U_{\max}	8.2 V
I_{\max}	16 mA
4-wire PT100 input per stream	
Number intrinsically safe	1x PT100 input with 4 terminals for resistance measurement (T--, T-, T+, T++) <ul style="list-style-type: none"> - The PT100 input is intrinsically safe – Ex limits must be observed without fail!
Number not intrinsically safe	1x PT100 input with 4 terminals for resistance measurement (T1--, T1-, T1+, T1++)

Temperature range	-20 °C to 60 °C
Resolution	24 bit ADC
U_{\max}	5 V
I_{\max}	1.6 mA, typ. 0.8 mA
Measurement rate	>2 Hz
Alarm/warning outputs per stream	
Quantity	2x warning outputs and 2x alarm outputs <ul style="list-style-type: none"> ■ W-NC and W-NO ■ A-NC and A-NO
U_{\max}	24 V DC
I_{\max}	30 mA
f_{\max}	2 Hz

Annex A Lead seal plan

Annex A.1 Single-Stream variant

The drawing consists of several views of the Flow Computer RFC 7:

- Top-left view:** Shows the internal terminal block with 16 ports. Two ports are marked with a seal icon and labeled "Sicherungsmarke seal".
- Bottom-left view:** Shows the front panel with a large blank area for a seal, labeled "Sicherungsmarke seal".
- Right-side view:** Shows the side of the device with a seal icon and label "Sicherungsmarke seal" pointing to a specific location.
- Bottom-right view:** Shows the front panel with a seal icon and label "Sicherungsmarke seal" pointing to the bottom edge.
- Top-right view:** Shows the top of the device with a seal icon and label "Sicherungsmarke seal" pointing to a location on the top edge.

Text in German:

Die Steckergehäuse sind optional und werden nur verwendet, wenn eine Plombe benötigt wird.
 Bei Verwendung von Ex-Transmittern, PT100 werden die Stecker X7 und X8 mit einer Plombe versehen.
 Bei Verwendung der Non-Ex-Transmitter, PT100 werden die Stecker X3 und X4 plombiert.

Text in English:

The connector housings are optional and are used only when a seal is required.
 When using Ex transmitters (Pt100), the connectors X7 and X8 are sealed.
 When using non-Ex transmitters (Pt100), the connectors X3 and X4 are sealed.

Legend: Sicherungsmarke seal

Table:

DRW-NO: 08759.3	DRW-N: Ramshaw
CHECK: 28.11.2024	DATE: 28.11.2024
INDEX: b	REV: 09.06.2026

TITLE: Plombenplan 42TE RFC 7 / Seal plan 42TE RFC 7

RMG Mess-technik GmbH
 Rüdiger-Mess-technik GmbH
 Phone +49 (0)6033 867 - 0

Annex A.2 Multi-Stream variant

The drawing illustrates the Multi-Stream variant of the flow computer RFC 7. It includes a top-down view of the connector panel, a front view, and a back view. Each view highlights the 'Sicherungsmarke seal' (tamper seal) locations. A detail view shows a connector housing seal with a tamper seal and a warning symbol.

Die Steckergehäuse sind optional und werden nur verwendet, wenn eine Plombe benötigt wird.
Bei Verwendung von Exi-Transmittern, PT100 werden die Stecker X3 und X4 plombiert.
Bei Verwendung der Non-Ex-Transmitter, PT100 werden die Stecker X3 und X4 plombiert.

The connector housings are optional and are used only when a seal is required.
When using Exi transmitters (PT100), the connectors X3 and X4 are sealed.
When using non-Ex transmitters (PT100), the connectors X3 and X4 are sealed.

DRW.-NO: 068767.3
DRAWN: Ramshaw
CHECK:
DATE: 28.11.2024
INDEX: b
REV.: 09.06.2026

TITLE:
Plombenplan 84TE RFC 7 / Seal plan 84TE RFC 7

RMG
RMG Messtechnik GmbH
www.rmg.com
Phone +49 (0)9133 897 - 0

Annex B Declaration of conformity

NOTE

EU declaration of conformity

The declaration of conformity presented reflects the situation on the data when the operating manual was issued. The latest version of the EU declaration of conformity is available from our website www.rmg.com.

EU-Declaration of Conformity EU-Konformitätserklärung



We **RMG Messtechnik GmbH**
Wir Otto – Hahn – Straße 5
35510 Butzbach
Germany

Declare under our sole responsibility that the product is in conformity with the directives. Product is labeled according to the listed directives and standards and in accordance with the Type-Examination.

Erklären in alleiniger Verantwortung, dass das Produkt konform ist mit den Anforderungen der Richtlinien. Das entsprechend gekennzeichnete Produkt ist nach den aufgeführten Richtlinien und Normen hergestellt und stimmt mit dem Baumuster überein.

Product **Flow Computer RFC 7**
Produkt **Mengenumwerter RFC 7**

Harmonisation Legislations <i>Harmonisierungsrechtsvorschriften</i>	EMV	ATEX	MID
EU-Directives <i>EU-Richtlinie</i>	2014/30/EU	2014/34/EU	2014/32/EU
Marking <i>Kennzeichen</i>	---	II (2)G [Ex ib Gb]	---
Normative Documents <i>Normative Dokumente</i>	EN 55011:2016/A11:2020 EN 12405-3:2016 in parts EN 61000-4-2: 2009 EN 61000-4-3:2020 EN 61000-4-4:2013 EN 61000-4-5:2019 EN 61000-4-6:2014 EN 61000-4-8:2010 EN 61000-4-17:2005 EN 61000-4-29:2001 OIML R137-2 in parts	EN IEC 60079-0: 2018 EN 60079-11: 2012	EN12405-1:2021
EC Type-Examination issued by <i>EG-Baumusterprüfung ausgestellt durch</i>	Prüfbericht / Test Report: 1-6664-23-01-02_TR1-R01 Cetecom advanced GmbH Saarbrücken / Germany	BVS 23 ATEX E 027 X Dekra Testing and Certification GmbH Bochum / Germany	DE-26-MI002-PTB001 PTB Braunschweig / Germany
Approval of a Quality System by <i>Anerkennung eines Qualitätssicherungs-systems durch</i>	---	Modul D BVS 23 ATEX ZQS/E139 Notified Body: 0158 DEKRA Testing and Certification GmbH Bochum / Germany	Modul D DE-M-AQ-PTB023 Notified Body: 0102 PTB Braunschweig / Germany



The object of the declaration described above is in conformity with Directive 2011/65/EU of the European Parliament and of the Council of 8 June 2011 on the restriction of the use of certain hazardous substances in electrical and electronic equipment.

Der oben beschriebene Gegenstand der Erklärung erfüllt die Vorschriften der Richtlinie 2011/65/EU des Europäischen Parlaments und des Rates vom 8. Juni 2011 zur Beschränkung der Verwendung bestimmter gefährlicher Stoffe in Elektro- und Elektronikgeräten.

RMG Messtechnik GmbH
Butzbach, den 23.04.2026

Thorsten Dietz
(CEO)

Sascha Körner
(Technical Manager)

Sitz der Gesellschaft Butzbach • Registergericht Friedberg HRB 2535
Geschäftsführung Thorsten Dietz
Qualitätsmanagement DIN EN ISO 9001:2015

Seite 1 von 1

Annex C Approvals

Annex C.1 Measuring Instruments Directive 2014/32/EU – Volume conversion device for gas



Physikalisch-Technische Bundesanstalt
Nationales Metrologieinstitut

KBS

Konformitätsbewertungsstelle



EU-Baumusterprüfbescheinigung

EU Type-examination Certificate

Ausgestellt für: RMG Messtechnik GmbH
Issued to: Otto-Hahn-Str. 5
35510 Butzbach

gemäß: Anhang II Modul B der Richtlinie 2014/32/EU des Europäischen
In accordance with: Parlaments und des Rates vom 26. Februar 2014 zur Harmonisierung
der Rechtsvorschriften der Mitgliedstaaten über die Bereitstellung von
Messgeräten auf dem Markt.
*Annex II Module B of the Directive 2014/32/EU of the European Parliament and of the
Council of 26 February 2014 on the harmonisation of the laws of the Member States
relating to the making available on the market of measuring instruments.*

Geräteart: Zustands-Mengenurwerter für Gas
Type of instrument: Volume conversion device for gas

Typbezeichnung: RFC 7
Type designation:

Nr. der Bescheinigung: DE-26-MI002-PTB001
Certificate No.:

Gültig bis: 22.04.2036
Valid until:

Anzahl der Seiten: 35
Number of pages:

Geschäftszeichen: PTB-1.42-4111237
Reference No.:

Notifizierte Stelle: 0102
Notified Body:

Zertifizierung: Braunschweig, 23.04.2026
Certification:

Im Auftrag
On behalf of PTB



Dr. Daniel Schumann

Siegel
Seal



Bewertung:
Evaluation:

Im Auftrag
On behalf of PTB

Dr. Roland Schmidt

R3-072096

Annex C.2 Measures and Verification Ordinance – Energy conversion device



Physikalisch-Technische Bundesanstalt
Nationales Metrologieinstitut

KBS

Konformitätsbewertungsstelle



Baumusterprüfbescheinigung

Type-examination Certificate

Ausgestellt für: RMG Messtechnik GmbH
Issued to: Otto-Hahn-Str. 5
35510 Butzbach

gemäß: Anlage 4 Modul B der Mess- und Eichverordnung vom 11.12.2014
In accordance with: (BGBl. I S. 2010)
Annex 4 Modul B of the Measures and Verification Ordinance dated 11.12.2014
(Federal Law Gazette I, p. 2010)

Geräteart: Brennwert-Mengenwerverer
Type of instrument: Energy conversion device

Typbezeichnung: RFC 7
Type designation:

Nr. der Bescheinigung: DE-26-M-PTB-0007
Certificate No.:

Gültig bis: 22.04.2036
Valid until:

Anzahl der Seiten: 34
Number of pages:

Geschäftszeichen: PTB-1.42-4126017
Reference No.:

Nr. der Stelle: 0102
Body No.:

Zertifizierung: Braunschweig, 23.04.2026
Certification:

Im Auftrag **Siegel**
On behalf of PTB *Seal*

Bewertung:
Evaluation:

Im Auftrag
On behalf of PTB

Dr. Daniel Schumann



Dr. Roland Schmidt

Baumusterprüfbescheinigungen ohne Unterschrift und Siegel haben keine Gültigkeit. Diese Baumusterprüfbescheinigung darf nur unverändert weiterverbreitet werden. Auszüge bedürfen der Genehmigung der Physikalisch-Technischen Bundesanstalt.
Type-examination Certificates without signature and seal are not valid. This Type-examination Certificate may not be reproduced other than in full. Extracts may be taken only with the permission of the Physikalisch-Technische Bundesanstalt.

R3-0010

Annex C.3 Measures and Verification Ordinance – Load Recorder and indicating device for the maximum load



Physikalisch-Technische Bundesanstalt
Nationales Metrologieinstitut

KBS

Konformitätsbewertungsstelle



Baumusterprüfbescheinigung

Type-examination Certificate

Ausgestellt für: <i>Issued to:</i>	RMG Messtechnik GmbH Otto-Hahn-Str. 5 35510 Butzbach
gemäß: <i>In accordance with:</i>	Anlage 4 Modul B der Mess- und Eichverordnung vom 11.12.2014 (BGBl. I S. 2010) <i>Annex 4 Modul B of the Measures and Verification Ordinance dated 11.12.2014 (Federal Law Gazette I, p. 2010)</i>
Geräteart: <i>Type of instrument:</i>	Belastungs-Registriergerät <i>Load recorder</i> und Höchstbelastungs-Anzeigergerät <i>and indicating device for the maximum load</i>
Typbezeichnung: <i>Type designation:</i>	RFC 7
Nr. der Bescheinigung: <i>Certificate No.:</i>	DE-26-M-PTB-0008
Gültig bis: <i>Valid until:</i>	21.04.2036
Anzahl der Seiten: <i>Number of pages:</i>	13
Geschäftszeichen: <i>Reference No.:</i>	PTB-1.42-4126018
Nr. der Stelle: <i>Body No.:</i>	0102
Zertifizierung: <i>Certification:</i>	Braunschweig, 22.04.2026
Im Auftrag <i>On behalf of PTB</i>	Siegel <i>Seal</i>

Dr. Daniel Schumann



Bewertung:
Evaluation:
Im Auftrag
On behalf of PTB

Dr. Roland Schmidt

Baumusterprüfbescheinigungen ohne Unterschrift und Siegel haben keine Gültigkeit. Diese Baumusterprüfbescheinigung darf nur unverändert weiterverbreitet werden. Auszüge bedürfen der Genehmigung der Physikalisch-Technischen Bundesanstalt.
Type-examination Certificates without signature and seal are not valid. This Type-examination Certificate may not be reproduced other than in full. Extracts may be taken only with the permission of the Physikalisch-Technische Bundesanstalt.

RG-0010



Translation

1 **EU-Type Examination Certificate**

2 **Directive 2014/34/EU of the European Parliament and of the Council of 26 February 2014**

3 EU-Type Examination Certificate Number: **BVS 23 ATEX E 027 X** Issue: **00**

4 Equipment: **Electronic Assembly type IOC-Ex-IO**

5 Manufacturer: **RMG Messtechnik GmbH**

6 Address: **Otto-Hahn-Str. 5, 25510 Butzbach, Germany**

7 This product and any acceptable variations thereto are specified in the appendix to this certificate and the documents referred to therein.

8 DEKRA Testing and Certification GmbH, Notified Body number 0158, in accordance with Article 17 of Directive 2014/34/EU of the European Parliament and of the Council, dated 26 February 2014, certifies that this product has been found to comply with the Essential Health and Safety Requirements relating to the design and construction of products intended for use in potentially explosive atmospheres given in Annex II to the Directive. The examination and test results are recorded in the confidential Report No. BVS PP 25.2001 EU.

9 Compliance with the Essential Health and Safety Requirements has been assured by compliance with:

EN IEC 60079-0:2018 **General requirements**
EN 60079-11:2012 **Intrinsic Safety "i"**

10 If the sign "X" is placed after the certificate number, it indicates that the product is subject to the "Specific Conditions of Use" listed under item 17 of this certificate.

11 This EU-Type Examination Certificate relates only to the technical design of the specified product in accordance with the Directive 2014/34/EU. Further requirements of the Directive apply to the manufacturing process and supply of this product. These are not covered by this certificate.

12 The marking of the product shall include the following:

 **II (2)G [Ex ib Gb] IIC**

DEKRA Testing and Certification GmbH
 Bochum, 2025-01-20

Signed: Oliver Brumm

 Managing Director

13 **Appendix**

14 **EU-Type Examination Certificate**

BVS 23 ATEX E 027 X issue 00

15 **Product description**

15.1 **Subject and type**

Electronic Assembly type IOC-Ex-IO

15.2 **Description**

The Electronic Assembly type IOC-Ex-IO is an associated apparatus and it is used for the galvanic isolation from intrinsically safe field devices to non-intrinsically safe area. The device is only suitable for the installation in the non-intrinsically safe area. The intrinsically safe circuits of the Electronic Assembly type IOC-Ex-IO are suitable for use in zone 1.

Listing of all components used referring to older standards
None

15.3 **Parameters**

Electrical parameters:

Connector STK18 (supply circuit)

Maximum input voltage: U_m AC 250 V
Nominal input voltage: U_n DC 12 V +/- 2 %

Connector X7 (Pin 1+, Pin 2-) Namur impulsinput 3

Maximum output voltage: U_o DC 12.1 V
Maximum output current: I_o 13.9 mA
Maximum output power: P_o 42 mW

Maximum external inductance and capacitance with separated of C_o or L_o :

Maximum external capacity: C_o 1.37 μ F
Maximum external inductance: L_o 100 mH

Maximum external inductance and capacitance if concentrated C_o and L_o are connected:

C_o	0.5 mH	1.0 mH	2.0 mH	5.0 mH
L_o	720 nF	620 nF	540 nF	460 nF

Connector X7 (Pin 4+, Pin 5-) 4-20 mA Current transmitterinput 1

Maximum output voltage: U_o DC 28.0 V
Maximum output current: I_o 77.2 mA
Maximum output power: P_o 539 mW

Maximum external inductance and capacitance with separated of C_o or L_o :

Maximum external capacity: C_o 79 nF
Maximum external inductance: L_o 2.8 mH

Maximum external inductance and capacitance if concentrated C_o and L_o are connected:

C_o	0.5 mH	1.0 mH	1.5 mH	2.0 mH
L_o	71 nF	55 nF	48 nF	43 nF

Connector X7 (Pin 7+, Pin 8-) 4-20 mA Current transmitterinput 2

Maximum output voltage: U_o DC 28.0 V
Maximum output current: I_o 77.2 mA

Page 2 of 4 of BVS 23 ATEX E 027 X issue 00 – Jobnumber A 20211434 / 342584800
This certificate may only be reproduced in its entirety and without any change.

DEKRA Testing and Certification GmbH, Handwerkstr. 15, 70565 Stuttgart, Germany
Certification body: Dimmendahlstr. 9, 44809 Bochum, Germany
Phone +49.234.3696-400, Fax +49.234.3696-401, e-mail DTC-Certification-body@dekra.com



Maximum output power: P_o 539 mW

Maximum external inductance and capacitance with separated of C_o or L_o :

Maximum external capacity: C_o 79 nF
 Maximum external inductance: L_o 2.8 mH

Maximum external inductance and capacitance if concentrated C_o and L_o are connected:

C_o	0.5 mH	1.0 mH	1.5 mH	2.0 mH
L_o	71 nF	55 nF	48 nF	43 nF

Connector X8 (Pin 1 - Pin 4) 4 Wire Resistorinput

Maximum output voltage: U_o DC 7.2 V
 Maximum output current: I_o 18.5 mA
 Maximum output power: P_o 33.5 mW

Maximum external inductance and capacitance with separated of C_o or L_o :

Maximum external capacity: C_o 13.5 μ F
 Maximum external inductance: L_o 97 mH

Maximum external inductance and capacitance if concentrated C_o and L_o are connected:

C_o	1.0 mH	2.0 mH	5.0 mH	10.0 mH
L_o	1800 nF	1500 nF	1200 nF	950 nF

Connector X8 (Pin 5+ - Pin 6-) 4 Reed / Namur 1

Maximum output voltage: U_o DC 12.1 V
 Maximum output current: I_o 13.9 mA
 Maximum output power: P_o 42 mW

Maximum external inductance and capacitance with separated of C_o or L_o :

Maximum external capacity: C_o 1.37 μ F
 Maximum external inductance: L_o 100 mH

Maximum external inductance and capacitance if concentrated C_o and L_o are connected:

C_o	0.5 mH	1.0 mH	2.0 mH	5.0 mH
L_o	720 nF	620 nF	540 nF	460 nF

Connector X8 (Pin 7+ - Pin 8-) 4 Reed / Namur 2

Maximum output voltage: U_o DC 12.1 V
 Maximum output current: I_o 13.9 mA
 Maximum output power: P_o 42 mW

Maximum external inductance and capacitance with separated of C_o or L_o :

Maximum external capacity: C_o 1.37 μ F
 Maximum external inductance: L_o 100 mH

Maximum external inductance and capacitance if concentrated C_o and L_o are connected:

C_o	0.5 mH	1.0 mH	2.0 mH	5.0 mH
L_o	720 nF	620 nF	540 nF	460 nF

Rated ambient temperature range: $-25\text{ }^\circ\text{C} \leq T_{amb} \leq 60\text{ }^\circ\text{C}$

16

Report Number

BVS PP 25.2001 EU, as of 2025-01-20

Page 3 of 4 of BVS 23 ATEX E 027 X issue 00 – Jobnumber A 2021 1434 / 342584800
 This certificate may only be reproduced in its entirety and without any change.

DEKRA Testing and Certification GmbH, Handwerkstr. 15, 70565 Stuttgart, Germany
 Certification body: Dinnendahlstr. 9, 44809 Bochum, Germany
 Phone +49.234.3696-400, Fax +49.234.3696-401, e-mail DTC-Certification-body@dekra.com





- 17 **Specific Conditions of Use**
 - The Electronic Assembly type IOC-Ex-IO must be installed outside the hazardous area in an enclosure that guarantees at least IP20 protection in accordance with EN 60529.
 - The Electronic Assembly type IOC-Ex-IO can be used in an ambient temperature range of -25 °C to +60 °C.
- 18 **Essential Health and Safety Requirements**

Met by compliance with the requirements mentioned in item 9.
- 19 **Remarks and additional information**

Drawings and documents are listed in the confidential report.

We confirm the correctness of the translation from the German original.
 In the case of arbitration only the German wording shall be valid and binding.

DEKRA Testing and Certification GmbH
 Bochum, 2025-01-20
 BVS-HRH/MGR A 20211434 / 3425848

 Managing Director

Page 4 of 4 of BVS 23 ATEX E 027 X Issue 00 – Jobnumber A 20211434 / 342584800
 This certificate may only be reproduced in its entirety and without any change.

DEKRA Testing and Certification GmbH, Handwerkstr. 15, 70565 Stuttgart, Germany
 Certification body: Dinnendahlstr. 9, 44809 Bochum, Germany
 Phone +49.234.3696-400, Fax +49.234.3696-401, e-mail DTC-Certification-body@dekra.com



Personal Notes



ONE STEP AHEAD

Subject to change without notice!

RMG Messtechnik GmbH

Otto-Hahn-Straße 5
35510 Butzbach
Germany

Phone: +49 (0) 6033 897 – 0
Fax: +49 (0) 6033 897 – 130
Email: info@rmg.com

www.rmg.com

Additional information

If you would like to find out more about RMG's products and solutions, visit our website: www.rmg.com or contact your customer adviser.