

## Operating Manual

---

# Data Logger Prilog 400

Status: APRIL, 17TH 2026  
Version: 03

**Manufacturer** Contact our customer service department for technical information.

<b>Address</b>	RMG Messtechnik GmbH Otto-Hahn-Straße 5 D-35510 Butzbach (Germany)
<b>Main office</b>	+49 6033 897 – 0
<b>Service</b>	+49 6033 897 – 897
<b>Spare parts</b>	+49 6033 897 – 117
<b>Fax</b>	+49 6033 897 – 130
<b>Email</b>	<a href="mailto:service@rmg.com">service@rmg.com</a>



You can register your product on our website at <https://www.rmg.com/en/help/device-registration>.  
By this you are helping us to improve our support

**Note** The latest version of this manual (and the manuals other devices) can be downloaded at your convenience from our Internet page:

[www.rmg.com](http://www.rmg.com).

<b>Created</b>	February 2020
<b>1<sup>st</sup> Revision</b>	November 2021
<b>2<sup>nd</sup> Revision</b>	October 2023

**Document version and language**

<b>Document version</b>	Prilog400_MAN_V03_04.2026_30.00.663.00-EN April, 17th 2026
<b>Language</b>	EN

# CONTENTS

<b>CONTENTS</b> .....	I
Symbols and Terms .....	V
<b>1 Introduction</b> .....	1
1.1 Basic Description of the Device .....	1
1.2 Securing the Device .....	4
1.3 Versions of the Device .....	4
1.3.1 Prilog 400 .....	5
<b>2 Safety</b> .....	6
2.1 General .....	6
2.2 Using the Device in Potentially Explosive Atmospheres .....	7
2.3 Special Conditions for Use .....	8
2.4 Connecting External Devices .....	8
<b>3 Technical Parameters</b> .....	9
3.1 Design and Operation .....	9
3.2 Environment .....	9
3.3 Safety, Explosion Protection .....	10
3.4 Data Logger Power Supply .....	10
3.5 Measurement Parameters .....	11
3.5.1 General .....	11
3.5.2 Pressure Measurement .....	11
3.5.3 Temperature measurement .....	13
3.6 Digital inputs .....	13
3.7 Digital Outputs .....	15
3.8 Communication Inputs/Outputs .....	15
3.9 Data Archiving .....	16
3.10 Optional Extension .....	16
3.10.1 Interface modules for connecting the gas meter encoders .....	16
3.10.2 Communication Modules .....	17
3.10.3 Modules for Connecting External Power Supply .....	19
3.10.4 Analogue Inputs/Outputs Modules .....	20
3.10.5 Other Modules .....	20
<b>4 Explosion Safety Parameters</b> .....	22
<b>5 Installation and Commissioning</b> .....	26
5.1 Dimensions of the Device .....	26
5.1.1 Prilog 400 data logger .....	26
5.2 Security Marks of the Device .....	27
5.3 Example for Data Plate .....	29
5.4 Mechanical Installation .....	30
5.4.1 Mounting the Device on the Plate .....	31
5.4.2 Mounting the Device on a Pipe .....	33
5.4.3 Connecting the Pressure Transducer .....	34
5.4.4 Connecting the Temperature Transducer .....	34
5.5 Electrical Connection .....	36
5.5.1 Connecting Cables .....	36
5.5.2 Connecting Gas Meters .....	40
5.5.3 Connecting Binary Inputs .....	44
5.5.4 Connecting Digital Outputs .....	44
5.5.5 Connecting Analog outputs .....	46

5.5.6	Connection of pressure and temperature transducers .....	46
5.5.7	Connecting External Power Supply .....	48
5.5.8	Connection of RS232/RS485 Communication .....	52
5.5.9	Connection to Network (Ethernet) .....	54
5.6	Commissioning .....	55
5.6.1	Connecting the Battery .....	56
5.6.2	Connecting the Modem Battery .....	57
5.6.3	Installing SIM Card in the Modem .....	58
6	Operating the Device .....	59
6.1	Keypad .....	60
6.2	System Menu.....	61
6.3	Main Menu.....	64
6.4	Actual Values Menu.....	65
6.5	Archives Menu.....	65
6.6	Device Parameters Menu .....	67
6.7	Device Configuration Menu .....	69
6.8	System data Menu.....	70
6.8.1	About Device .....	70
6.8.2	Device Reset .....	70
6.8.3	Communication.....	71
6.8.4	Frozen Values .....	75
6.9	Diagnostics .....	76
6.9.1	Current Status .....	76
6.9.2	Summary Status .....	76
6.9.3	Summary Status Reset.....	76
6.9.4	Device Test.....	77
6.9.5	Device Errors Display .....	77
6.9.6	Status Word of the Device.....	79
7	Technical Description of the Device.....	80
7.1	Architecture of the Device .....	80
7.2	Main parts of the device .....	81
7.3	Modules, Principles of Use.....	83
7.3.1	Installing the Modules.....	84
7.3.2	Installing the External Power Supply of the Modem .....	86
7.3.3	Replacement of the Modem .....	87
7.4	Power Supply of the Device .....	88
7.4.1	Batteries to Power the Device .....	89
7.4.2	Replacing the Battery .....	91
7.4.3	Battery to Power the Modem .....	93
7.4.4	Replacing the Modem Battery .....	94
7.4.5	Back-up Battery .....	94
7.4.6	External Power Supply .....	95
7.5	Digital Outputs, Modified Use .....	96
7.6	Internal Modem, Using External Antenna.....	97
7.6.1	Using the Device with an External Antenna .....	97
7.6.2	Modifying the Device for Connecting an External Antenna to the Modem.....	98
7.7	Software .....	100
7.7.1	Downloading Application Firmware Using “Remote Download“ Method .....	100
7.7.2	Storing Data in the Device.....	100
7.8	Principle of the Function .....	101
7.8.1	Disturbed Quantity Counters .....	101
7.8.2	Volume Correction under the Measurement Conditions.....	101
8	Metrological Features.....	103

8.1	Temperature Measurement.....	103
8.2	Pressure Measurement.....	104
8.3	Volumes Measurement and Calculation .....	104
8.3.1	Activities at Error Conditions Occurrence.....	104
8.3.2	Respecting the Change of the Gas Flow Direction in the Gas Meter.....	105
9	Connecting Inputs.....	106
9.1	LF Pulse Inputs .....	107
9.2	Binary Inputs .....	107
9.3	HF Pulse Inputs (NAMUR).....	108
9.4	Connecting a Gas Meter with an Encoder .....	108
9.4.1	Device Specifics when using the Encoders.....	108
9.4.2	Gas Meter Installing and Replacing .....	109
10	Communication with the Device.....	110
10.1	EN 62056-21 (IEC-1107) Optical Interface .....	112
10.2	Modules of the Internal Modems.....	112
10.3	Connecting communication devices via RS232 interface .....	113
10.3.1	Connecting an external modem .....	114
10.4	Encrypting Data when Communicating with the Master System.....	114
11	Function Description .....	115
11.1	Quantities Designation .....	115
11.2	Actual Values .....	115
11.3	Archives .....	116
11.3.1	Monthly Archive.....	117
11.3.2	Daily Archive .....	117
11.3.3	Data Archive.....	117
11.3.4	Binary Archive .....	117
11.3.5	Limit Archive.....	118
11.3.6	Status Archive .....	118
11.3.7	Settings Archive .....	118
11.4	Device Parametrization .....	118
11.4.1	SW Parameterization Using the Operating SW.....	118
11.5	Other Features of the Device .....	118
11.5.1	Summer/Winter Time (DST).....	118
11.5.2	Time Synchronization.....	119
11.5.3	Tarif Counters.....	119
11.6	Protection against change of Metrological Parameters.....	119
11.6.1	Protection Switches.....	119
11.6.2	Passwords.....	120
11.6.3	Levels of Access .....	123
12	Accessories .....	125
12.1	Plug-in Modules for Prilog 400 data logger .....	125
12.2	External Modules .....	126
12.2.1	Intrinsically Safe Sources for External Power Supply .....	126
12.2.2	Separation and Communication Modules .....	126
12.3	Other Accessories.....	128
12.4	Order numbers for spare parts and accessories .....	128
Appendix	.....	130
A	System Menu .....	130
A.1	Main Menu.....	130
B	Prilog 400 Version for Zone 2 .....	137
B.1	Introduction.....	137

	B.2	Safety .....	138
	B.3	Safety parameters of signals on terminals .....	141
	B.4	Device identification of Prilog 400 for Zone 2 .....	143
	B.5	Product features .....	144
	B.6	Technical design.....	145
	B.7	Technical parameters – modules for external power supply .....	147
IV	B.8	Connection of inputs and outputs .....	148
	B.9	Examples - block diagram of connection.....	156
	C	Configuration Ethernet Connection via FL Comserver .....	158
	D	References .....	160
	E	Related Documents .....	160
	F	Software .....	161
	G	Trade Marks Used .....	161
	H	List of Figures .....	161
	I	List of Tables .....	164
	J	Certificates.....	165

## Symbols and Terms

Symbol		Meaning	Unit
ASC	...	Authorized Service Centre	
BTS	...	Base Transceiver Station	
CLO	...	4-20mA current output module	
CRC	...	checksum - for data protection purposes	
CTR	...	communication protocol	
DC, dc	...	DC voltage	
dE	...	increment of energy totalizer	MJ
dE <sub>s</sub>	...	increment of energy totalizer under error conditions	MJ
dV	...	increment of primary volume totalizer V <sub>m</sub> or V	m <sup>3</sup>
dV <sub>c</sub>	...	increment of corrected primary volume totalizer V <sub>c</sub>	m <sup>3</sup>
dV <sub>m</sub>	...	increment of primary volume totalizer	m <sup>3</sup>
E	...	energy	MJ
E <sub>s</sub>	...	energy under error conditions	MJ
EDTxx		digital transducer of pressure EDT 96 or of temperature EDT 87	
ECconf	...	Communication protocol developed by RMG	
EMC	...	electromagnetic compatibility and resistivity	
EVC		Electronic gas volume corrector	
Ex i	...	intrinsically safe, intrinsic safety	
firmware, FW	...	software in the device	
Modbus	...	Modicon communication protocol [13]	
MPE	...	maximum permissible error	
M900	...	RMG communication protocol	
SW	...	software – PC program	
k <sub>p</sub>	...	gas meter constant (number of pulses per 1m <sup>3</sup> )	imp/m <sup>3</sup>
N	...	number of input pulses from the gas meter	imp
p	...	absolute pressure at metering conditions	bar
Q	...	flow rate at measurement conditions (primary flow rate)	m <sup>3</sup> /h
Q <sub>b</sub>	...	flow rate at base conditions (converted flow rate)	m <sup>3</sup> /h
T	...	absolute temperature at measurement conditions (T = t + 273,15)	K
t	...	gas temperature	°C
V	...	volume V <sub>m</sub> or V <sub>c</sub>	
V <sub>m</sub>	...	volume at measurement conditions (primary volume)	m <sup>3</sup>
V <sub>c</sub>	...	corrected volume at measurement conditions (volume corrected based on correction profile of the gas meter)	m <sup>3</sup>
V <sub>s</sub>	...	volume at measurement conditions under error conditions (disturbed quantity)	m <sup>3</sup>
V <sub>d</sub>	...	primary volume difference	m <sup>3</sup>

---

VI

---

---

---

---

# 1 Introduction

## 1.1 Basic Description of the Device

The Prilog 400 data loggers (hereinafter referred to as the device) are devices designed to store the volume of gas measured under operating conditions.

The gas volume information is scanned through the gas meter's pulse outputs or through the encoder data output. Gas temperature and gas pressure can optionally be measured with integrated transducers.

From a safety point of view, the device has been designed to be intrinsically safe according to EN 60079-11 and approved for potentially explosive atmospheres.

The device is manufactured and delivered in accordance with the following directives of the European Parliament and of the Council:

2014/34/EU	(ATEX) Equipment and protective systems intended for use in potentially explosive atmospheres
2014/30/EU	Electromagnetic Compatibility
2014/53/EU	(RED) Radio Equipment and Telecommunication Broadcasting Equipment
2011/65/EU	(RoHS) Restriction of (the use of certain) Hazardous Substances in electrical and electronic Equipment

The device is placed on the market and put into service according to the above-mentioned directives with the CE mark affixed.

The device is built in a housing made of durable plastic with IP66 rating. It is equipped with a graphic display and 6-key keypad.

The data logger is powered by a battery. In the defined operating mode (see section 7.4.1), the battery life is 15 years. The Prilog 400 device can be additionally powered from an external power supply where the built-in battery has the function of a backup battery.

For gas pressure measurement, the device is optionally equipped with a digital pressure sensor positioned in the bottom of the device housing and which is connected to the gas meter via an Ermeto coupling. An optional digital temperature transducer, which is already connected via cable in delivery state, is used to measure the gas temperature. The gas meter information on gas consumption can be transferred to the data logger from the pulse output of the meter or from the gas meter encoder data output.

In addition to the pulse inputs, the device also has binary inputs that can work for example as control inputs to check the connection to a gas meter or perform other functions such as monitoring the state of a safety quick closing valves, condition of a door etc. The device has also digital outputs that can be configured as pulse, binary, or data outputs for the CLO module. Analogue current output can be implemented using this module.

2

To store the values, the device uses several types of internal archives. The data archive stores the measured and calculated values, has an adjustable structure with an adjustable storing frequency. In the daily and monthly archives, it is possible to program the storing of important quantities and the calculation and storage of some statistical values. The binary archive captures changes on binary inputs and occurrence of supervised events (limits, ...). Error states and diagnostics are stored in the status archive. In the settings archive, parameter changes that affect the device functions are recorded for service and official purposes. In addition, other archives are available; for more details, refer to Section 11.3.

## Note

### Trade Name of the Device

These instructions specify the features and parameters of **Prilog 400** electronic data logger. The device is also marketed as **Primus 400** volume corrector. These instructions apply to devices marketed under any of the trade names mentioned above.

**All the mentioned devices (both correctors and data loggers) are identical devices from the technical point of view (technical parameters, features) as well as from the safety point of view (ATEX). The Prilog 400 data logger is approved in Germany acc. to MessEG law and can only there be used for billing purposes.**

For devices delivered outside Germany no additional metrology marking is attached to the CE conformity marking.

The device is equipped with serial interface RS232/RS485 for communication with superior system. The various communication protocols installed in the device allow easier connection to SCADA systems. The device can be supplied with built-in modems of both fast communication networks and older 2G networks. In the event of an alarm condition, the device can initiate the connection itself. The device also works with standard wireless, GSM and GPRS modems via the RS232/RS485 line.

The device allows wide-range user parametrization. The device can be configured using the keypad of the device or the supplied PC software (see [19]). This software also allows reading, displaying and archiving both actual measured values and the internal archives contents.

## Main features

- robust cabinet designed for outdoor use, the cover can be closed without securing screws
- high immunity to electromagnetic interference (EMC)
- modular architecture for easy customization
- configurable digital inputs and outputs
- resistant capacitive keyboard for easy operation of the device
- display of actual and archival values - a graphic display option
- digital pressure and temperature transducers
- high capacity FLASH memory for internal archives for storing measured and calculated data
- communication with the device via several independent communication channels. It can be operated locally or remotely via an internal modem with different communication protocols
- each communication channel can communicate with different protocol
- communication is completely independent and does not affect the measurement, computation and data archiving
- possibility of remote download of the FW according to Welmec 7-2 Extension D
- several degrees of protection against device abuse have been implemented
- changing the device settings locally or remotely
- Prilog 400 as an electronic data logger for station monitoring and control
- the same technical solution for Primus 400 as an electronic volume corrector for billing purposes
- design enables further development

---

 3
 

---



---



---



---

## Prilog 400 device

- powerful modular model covering many end-user requirements
- battery operation up to 15 years without battery replacement (depending on operating mode)
- connecting gas meters with LF (reed, Wiegand), HF (NAMUR) pulse outputs, or various types of encoders (NAMUR, SCR +)
- use as a single-channel data logger
- modular architecture allows to create different configurations (up to 6 pressure or temperature transducers, 12 digital inputs, 4 digital outputs, 6 analog inputs and 4 analog outputs)
- battery power supplied devices with an option of external power supply
- Reading of NAMUR or SCR encoder in battery mode (without external power supply)
- 4 independent communication channels with communication speed up to 115 kBd
- possibility to connect up to two modems (internal + external or 2x external)

## 1.2 Securing the Device

The device is equipped with the following mechanisms against abuse:

### Sealing the device

- sealing of the closed device with the seal of the user and the possibility of locking the device by a lock (par. 5.2 and 5.5.1.2)
- sealing the connection of the pressure transducer to the pipeline (par. 5.4.3)
- sealing the connection of the temperature transducer to the pipeline (par. 5.4.4)

### Sealing of the internal parts (par. 5.2)

- protection of metrological parts by a metrological seal
- protection of selected non-metrological parts by the manufacturer's seal or by a user mark

### Tampering device detection

- detection of the opening of the device with the possibility of sending an alarm
- detection of removing metrological covers with the possibility of sending an alarm

### Device configuration and data protection (11.6)

- metrological switch - secured by a metrological seal, blocks the execution of operations that directly modify the metrological characteristics of the instrument (eg measuring accuracy, calibration of transducers, exchange of transducers, setting of special parameters, etc.)
- service switch - is used to block parameter settings that do not directly affect the device's metrological properties
- password security - optionally, you can use 50 passwords in 5 groups with different hierarchy of authority to modify the device settings
- encryption - protection of transmitted data by encryption (symmetric AES encryption with 128 bit encryption key length) This option is optional and can be used for data transmission by ECconf protocol or CTR protocol. (par. 10.4)

All changes to device parameter settings, along with the worker's identification mark, are stored in an indelible setting archive.

## 1.3 Versions of the Device

The data logger is manufactured and supplied in the type designated as Prilog 400. The Prilog 400 data loggers are certified for commercial measurement in Germany according to MessEG.

In terms of design and most of the technical parameters, Primus 400 is identical with Prilog 400; however, from the measurement point of view, it is approved according to MID and is intended as gas volume corrector. It can be used for fiscal metering purposes in EU.

### 1.3.1 Prilog 400

Prilog 400 can be supplied in a single channel design. Its features can be largely customized by additional modules. The device can be operated either as battery-powered or with an additional external power supply. In devices equipped with an internal modem, the modem is powered by a separate battery; alternately, it can be powered from an independent external power supply. Extension modules are inserted into slots (SLOT 0 to SLOT 5) on the input board.

#### a) Basic (minimum) configuration of the device:

- Single channel battery data logger
- Six-key keypad
- Graphic display
- 1 x (2 x) pulse input for connecting the gas meter with the LF pulse output
- 3 x (2 x) digital input
- 4 x digital output (binary, or pulse, or analogue)
- Optical interface
- 1 x data logger battery

#### b) The basic version can be extended by the following modules:

- 1 x digital pressure transducer EDT 96 for archiving
- 1 x digital temperature transducer EDT 87 for archiving
- 1 x interface module for gas meter with encoder (SLOT 0 position):
  - NAMUR interface module for NAMUR encoder; or
  - SCR interface module for SCR encoder; or
  - Module for connection of HF pulse output of gas meter (module EXT1)
  - module for connection of HF pulse output of gas meter and extension of digital and analogue inputs (EXT1 module with auxiliary terminal board EXT1-T)
- 1 x communication interface or analogue input/output module (SLOT 1 position):
  - Communication module RS232/RS485 for communication with the master system; or
  - Analogue input module 4 - 20 mA (2 inputs); or
  - Analogue output module 4 - 20 mA (2 outputs)
- 1 x communication interface or analogue input/output module (SLOT 2 position):
  - Communication module RS232/RS485 for communication with the master system; or
  - Analogue input module 4 - 20 mA (2 inputs); or
  - Analogue output module 4 - 20 mA (2 outputs)
- 1 x PWR1 module for connecting an external IS power supply for the device (SLOT 3)
- 1 x modem external power supply module or communication interface for external modem (SLOT 4 position):
  - PWR2 module to connect an external IS power supply to the modem, or
  - RS232 communication module for connecting an external modem
- 1 x internal modem module (SLOT 5<sup>1</sup> position) /including battery for internal modem/:
  - 2G modem (i.e. GSM, dial-up CSD and GPRS connection); or
  - LTE modem

The designations and features of the modules are specified in Section 3.10.

---

<sup>1</sup>) If the modem is not powered externally, the internal modem must be installed in SLOT 4 position.

## 2 Safety

### 2.1 General

6

Only a person trained in accordance with the specification, safety regulations and EN standards may operate the metering device. In addition, other legal and safety regulations for special cases of use in potentially explosive atmospheres must be taken into account. A similar measure applies to the use of the accessories. Training for the operators must be in accordance with Decree 50/1978Sb. or national equivalent standard as amended.

The information in these instructions do not establish legal commitment by the manufacturer. The manufacturer reserves the right to change them. Changes in the instructions or of the product itself may be made at any time without prior notice in order to improve the device or to correct typographical or technical errors.

The device has been approved according to Directive 2014/34/EU and the following certificates has been issued for it:

<b>FTZÚ 19 ATEX 0034X</b>	EU type-examination certificate (ATEX) for use in potentially explosive atmospheres.
---------------------------	--

#### Important Notices:

#### **Caution**

The device has been designed in accordance with safety rules for use in potentially explosive atmospheres. It has been approved as an intrinsically safe device in accordance with EN 60079-11.

#### **Danger**

The device must be installed and used in accordance with this documentation and the conditions stated in the ATEX certificate.

#### **Warning**

Only batteries listed in the technical parameters table (see Sections 3.4 and 3.10.2) may be used to power the device.

The battery replacement procedure should be performed in accordance with this documentation (see Sections 7.4.2 and 7.4.4).

#### **Warning**

The IP66 rating is valid only if correctly tightened cables of the appropriate diameter are used in the cable glands of the device. Unused cable glands must be blinded.

## 2.2 Using the Device in Potentially Explosive Atmospheres

Based on the EU type-examination certificate 19 ATEX 0034X, the device in the basic battery-powered version may be operated in areas with explosive atmospheres designated as ZONE 0. If the internal modem is powered externally, or when using an SCR encoder, the device is approved for ZONE1 environment.

The marking of the device in terms of explosion safety depends on the extension modules fitted:

### Prilog 400 (Primus 400)

Designation of explosion safety	Device and its internal equipment	Environment
II 1G Ex ia IIB T4 Ga	- basic design including module extensions: S0-NAM interface for NAMUR gas meter encoder, S0-EXT1 extension module, S1-COM1 RS232/RS485 communication module, S1-2AI Analog inputs module, S1-2AO Analog outputs module, S3-PWR1 EVC external power supply module, S4-COM0 – RS232 communication module	<b>ZONE 0</b>
II 1G Ex ia IIB T3 Ga	- <b>when installed by the module:</b> M2G internal 2G modem, M4G internal LTE-Cat1 modem or internal LTE-Cat M1 modem	<b>ZONE 0</b>
II 2G Ex ib IIA T3 Gb	- <b>when installed by the module:</b> S4-PWR2 external power supply of the internal modem module	<b>Zone 1</b>
II 2G Ex ib IIB T4 Gb	- <b>when installed by the module:</b> S0-SCR interface for SCR gas meter encoder	<b>Zone 1</b>

### **Caution**

The device has been designed and approved as intrinsically safe. This means that only approved devices (intrinsically safe devices, connection devices) or “Simple Devices” meeting the EN 60079-11 standard and complying with intrinsically safe parameters listed in the EU type-examination certificate [14] may be connected to all terminals of the device.

**When connecting the device, the valid safety standards must be observed.**

When connecting the device, the electrical characteristics of the connecting cables must be considered and the requirements of the valid safety standards met. Additionally, the Special conditions for Use must be observed, if listed in these Certificates. The explosion safety parameters of the device are specified in Section 4.

## 2.3 Special Conditions for Use

### Warning

The device must not be installed in places where external conditions can lead to electrostatic charging. It must be installed and operated in such a way that there is no electrostatic charge that could trigger an explosion. The device may only be cleaned with a damp cloth.

8

## 2.4 Connecting External Devices

Intrinsically safe devices can be connected to all the connection terminals of the device. When connecting external devices to these terminals, the intrinsic safety principles must be followed. The equipment must be connected in accordance with applicable standards, in particular:

EN 60079-25: Explosive atmospheres - Part 25: Intrinsically safe electrical systems;

EN 60079-14: Explosive atmospheres- Part 14: electrical installations design, selection and erection;

EN 60079-0: Explosive gas atmospheres, Part 0: Equipment - General requirements;

EN 60079-11: Explosive atmospheres - Part 11: Equipment protection by intrinsic safety "i".

The valid (current) version is to be applied.

The intrinsic safety parameters of the connection terminals are specified in Section 4. The recommended cable types are listed in Section 5.5.

## 3 Technical Parameters

### 3.1 Design and Operation





	Prilog 400
Mechanical dimensions (W x H x D)	263 x 201 x 111mm
Weight	2.2 kg
Cabinet material	PC+GF (polycarbonate + fibreglass)
Recommended installation position	vertical
Connecting Terminals - Conductor cross section	0.5 mm <sup>2</sup> – 2.0 mm <sup>2</sup>
Mechanical Environment Class	M2
Electromagnetic Environment Class	E2
System time of the device	
- Long-term stability	± 5 min/year at 25 °C
Keypad	Capacitive, 6-key
Displaying	LCD graphic display, 128 x 64 pixels, backlit

9

### 3.2 Environment

IP Rating	IP66, according to EN 60529
Operating temperature	-25 °C – +70 °C
Storage temperature	-40 °C – +85 °C
Working environment	according to EN 60721-3-4, class 4K3
Measurement of the device internal temperature	
- Location	integrated sensor in CPU module
- Measurement error	±3 °C

### 3.3 Safety, Explosion Protection

	Prilog 400
Explosion Safety Level <sup>2)</sup>	
- Basic version	 II 1G Ex ia IIB T4 Ga
- With internal modem (battery-powered)	 II 1G Ex ia IIB T3 Ga
- With internal modem powered from external source S4-PWR2	 II 2G Ex ib IIA T3 Gb
- With SCR encoder interface	 II 2G Ex ib IIB T4 Gb
Ambient temperature $T_{amb}$	$-40^{\circ}\text{C} \leq T_a \leq +70^{\circ}\text{C}$
Type of explosion protection	"I" – intrinsic safety
ES Type-Examination Certificate	FTZÚ 19 ATEX 0034X
Protection against dangerous contact of live and dead parts	by low voltage (SELV)

### 3.4 Data Logger Power Supply

	Prilog 400
- Type of battery	Lithium battery B-03 (17Ah) or B-03D (30Ah) battery
- Battery life - B-03 B-03D	11 years <sup>3)</sup> 15 years <sup>3)</sup>
- Battery voltage	3.6 V
- Battery life indication	Yes, alert when the capacity drops to 10%
- Optional external power supply of the data logger	Yes
- Module for the connection of EVC external power supply from IS source	S3-PWR1
- External power supply parameters	See the technical parameters of the S3-PWR1 module
<b>Back-up Battery of the Data Logger</b>	
- Back-up battery	yes (part of the CPU module)
- Back-up battery life	15 years <sup>3)</sup>

<sup>2)</sup> Depending on the configuration of the device, see Section 2

<sup>3)</sup> The lifetime of the battery depends on the mode set, the lifetime of the back-up battery depends on the way the device is used without the battery (see Section 7.4.1).

## 3.5 Measurement Parameters

### 3.5.1 General

Measurement principle	Data logger
Type-approval marking	DE-20-M-PTB-002, Revision 2 (MessEG certification)
Measurement Period	30 s (adjustable, range 1s – 1h)
<b>Period of official metrology check</b>	8 years - valid for Germany acc. to the German Weights and Measures Act (MessEV) - vary from country to country. In general, the validation period of a specified meter is determined by a country's decree.

11

### 3.5.2 Pressure Measurement

Number of pressure transducers	1
Designation of the pressure transducer	EDT 96 pressure transducer
Transducer version	internal - built-in in the device, or external - cable length 2.5 m as a standard (max. 100m in total for the connected EDTxx transducers)
Sensor	silicon piezoresistive sensor
Pressure connection	Ø 6 mm tube, ERMETO M12 x 1.5 threaded joint
Measurement of gas pressure within temperature range of	-25 – +70 °C
<b>Measurement ranges - MessEG certified</b>	
(absolute pressure values)	0.8 – 5.2 bar
	2.0 – 10 bar
	4.0 – 20 bar
	7.0 – 35 bar
	14 – 70 bar
	25 – 130 bar
	0.8 – 10 bar <sup>4)</sup>
	0.8 – 20 bar <sup>4)</sup>
	4.0 – 70 bar <sup>4)</sup>

<sup>4)</sup> Extended pressure range at extra charge.

- Measurement error	< 0.25 % of the measured value
- Long-term stability	< 0.1 % per year of the measured value
Overload capacity without changing metrological parameters	standardly: 1.25 x upper limit (UL) on request: 1,5 x UL for the range 0.8 – 20 bar 3 x UL for the range 0.8 – 10 bar 5 x UL for the range 0.8 – 5.2 bar
Mechanical resistance (without leakage)	2 times upper limit of the measurement range or 170 bar <sup>5)</sup> (whichever is lower)
<b>Measurement ranges - without MessEG certification</b>	
(absolute pressure values)	
	0.8 – 10 bar
	0.8 – 20 bar
	0.8 – 35 bar
	0.8 – 70 bar
	0.8 – 130 bar
- Measurement error	< 0.20 % of the range <sup>6)</sup>
- Long-term stability	standardly: < 0.2 % per year of the range <sup>6)</sup> on request: < 0.1 % per year of the scale <sup>6)</sup>
Overload capacity without changing metrological parameters	standardly: 1.25 x upper limit (UL) on request: 1,5 x UL for the range 0.8 – 20 bar 3 x UL for the range 0.8 – 10 bar 5 x UL for the range 0.8 – 5.2 bar
Mechanical resistance (without leakage)	2 x upper limit of the measurement range or 170 bar <sup>5)</sup> (whichever is lower)
<b>Measurement ranges - without MessEG certification</b>	
(relative pressure values)	0 – 0.2 bar
	0 – 1.0 bar
	0 – 1.6 bar
	0 – 4.0 bar
	0 – 6.0 bar
	0 – 10 bar
	0 – 25 bar
	0 – 40 bar
	0 – 70 bar

<sup>5)</sup> Pressure transducer is destroyed, gas-tightness remains.

<sup>6)</sup> For the device version without MessEG certification, measurement errors are specified in % of the range according to US common practice.

- Measurement error	< 0,20 % of the range (ranges 1 bar and higher) <sup>7)</sup> < 0,40 % of the range (ranges lower than 1 bar) <sup>7)</sup>
- Long-term stability	< 0,20 % of the range (ranges 1 bar and higher) <sup>7)</sup> < 0,40 % of the range (ranges lower than 1 bar) <sup>7)</sup>
Overload capacity without changing metrological parameters	2 x upper limit (UL)
Mechanical resistance (without leakage)	2 x upper limit of the measurement range or 170 bar <sup>5)</sup> (whichever is lower)

### 3.5.3 Temperature measurement

Number of temperature transducers	1
Designation of the pressure transducer	EDT 87 temperature transducer
Temperature sensor	Pt 1000 platinum resistance sensor
Transducer measurement range	-25 – +70 °C
- Measurement error	±0.2 °C (ie ± 0.09 % of the measured value in K)
- Long-term stability	< 0.02 % per year (relative error in K)
Sensor design	Ø 5.7 mm tube, measuring shank 50 mm long, integrated cable with electronics
Length of the sensor cable	2.5 m as a standard, (max. 100 m in total for the connected EDTxx transducers)

## 3.6 Digital inputs

A. Metrology	
- Number	2
- Terminals marking (DIN terminal blocks)	DI1, DI4
- Input options (SW configuration)	1 LF pulse input, 1 binary input/intrusion contact/LF pulse input to determine the direction of rotation of the meter
- Backup function in case of power supply failure	Yes, the signal monitoring function at the specified DI inputs is backed up by the backup battery of the device
- Cable length for each input	max. 30 m
- <b>LF pulse input</b>	Terminals DI1, DI4 (DI4 – for gas meters with the option of detecting the rotation direction)
- Maximum frequency	10 Hz
- Input type	Reed contact or potential-free output connection, WIEGAND
- Min. pulse/delay time	40 ms
- No-load voltage	2.5 V – 3.6 V
- Short-circuit current	ca 3 µA

<sup>7)</sup> For the device version without MID certification, measurement errors are specified in % of the range according to US common practice.

- "ON"	$R < 100 \text{ k}\Omega$ or $U < 0.2 \text{ V}$
- "OFF"	$R > 2 \text{ M}\Omega$ or $U > 2.5 \text{ V}$
<b>- Binary input, tamper contact</b>	
Terminals DI4 (Terminals DI1)	
- Input type	Low-power input, reed contact or potential-free output connection
- Min. duration of the condition	100 ms
- No-load voltage	2.5 V – 3.6 V
- Short-circuit current	ca 3 $\mu\text{A}$
- "ON" level	$R < 100 \text{ k}\Omega$ or $U < 0.2 \text{ V}$
- "OFF" level	$R > 2 \text{ M}\Omega$ or $U > 2.5 \text{ V}$
<b>B. Additional digital inputs</b>	
- Number	2
- Marking of the terminals (DIN terminal block)	DI2, DI3
- Input options (SW configuration)	2 LF pulse inputs, or 2 binary inputs, or 1 LF pulse input + 1 binary input
- Backup function in case of power supply failure	No
- Cable length for each input	30 m max.
<b>- LF pulse input</b>	
- Maximum frequency	10 Hz
- Input type	Reed contact or potential-free output connection, WIEGAND
- Min. pulse/delay time	40 ms
- No-load voltage	2.5 V – 3.6 V
- Short-circuit current	ca 3 $\mu\text{A}$
- "ON"	$R < 100 \text{ k}\Omega$ or $U < 0.2 \text{ V}$
- "OFF"	$R > 2 \text{ M}\Omega$ or $U > 2.5 \text{ V}$
<b>- Binary input</b>	
- Input type	Low-power input, reed contact or potential-free output connection
- Min. duration of the condition	100 ms
- No-load voltage	2.5 V – 3.6 V
- Short-circuit current	ca 3 $\mu\text{A}$
- "ON"	$R < 100 \text{ k}\Omega$ or $U < 0.2 \text{ V}$
- "OFF"	$R > 2 \text{ M}\Omega$ or $U > 2.5 \text{ V}$

### 3.7 Digital Outputs

Prilog 400	
- Number	4
- Marking of the terminals (DOUT terminal block)	DO1, DO2, DO3, DO4
- Output options (SW configuration)	Pulse output, binary output, analogue output (via CLO)
- Output type	Open collector
- Cable length for each output	30 m max.
- Galvanic separation	Yes (output circuit requires power to U0 +) *)
- Supply voltage range (terminal U0 +)	3.6 V – 15 V
- Max. output voltage (DO1-4)	15 V**)
- Max. output current	10 mA
- Max. resistance in closed state	5 Ω
<b>- Pulse output</b>	
- On time	Programmable 5 ms – 25 s
- Off time	Programmable 0.1 s – 25 s or adaptive
<b>- Analogue output</b>	
- Output realization	via external module CLO
- Type of output	4-20 mA current output, passive transmitter
- supply voltage range of current loop	5 V – 40 V
- accuracy	0.25% of the range (at 25 °C)

\*) DO1 and DO2 outputs can be operated in pulse output mode even without power supply at U0+ terminal with defined limitation: it requires a shorting jumper JP1 (the operating values drop - for more details refer to Section 7.5)

\*\*\*) JP1 shorting jumper must not be fitted, otherwise reduced voltage values apply for DO1, DO2 (see Section 7.5)

### 3.8 Communication Inputs/Outputs

Communication interface for optical head	
- Interface type	Interface IEC-1107
- Communication speed	9600 Bd to 115200 Bd, adjustable
- Communication protocol	Selectable, depending on the firmware version (see Section 10)

RS232/RS485 communication interface solution uses plug-in modules in SLOT 1, SLOT 2 or SLOT 4 (see par.3.10.2).

## 3.9 Data Archiving

Data archive	
- Archiving frequency $t_{\text{arch}}$	1 hour as standard (adjustable from 1 s to 1 h)
- Memory depth	ca. 112 000 records (i.e. ca. 12 years at $t_{\text{arch}}=1$ h), (changes dynamically depending on the configuration)
- Stored values	Vm, Vs, E, Es, Status, t, p, Q, Qb, C, K, Hs + adjustable depending on the configuration
Daily archive	
- Memory depth	ca. 4 200 records (ca. 11.5 years)
- Stored values	Vm, Vs, E, Es, Status, t, p, Q, C + adjustable depending on the configuration
Monthly archive	
- Memory depth	ca. 960 records (ca. 80 years)
- Stored values	Vm, Vs, E, Es, Status + adjustable depending on the configuration
Other archives (memory depth)	
- Binary archive	ca. 4 600 records
- Status archive	ca. 5 000 records
- Gas composition archive	ca. 1 870 records (ca. 5 years at 1 change per day)
- Settings archive	More than 1000 records (depending on the type of setting)
- Limit archive	1 record for each monitored quantity

## 3.10 Optional Extension

### 3.10.1 Interface modules for connecting the gas meter encoders

S0-NAM Interface module for ENCODER – NAMUR	
- Max. number of modules in the device	1
- Installation in the device	SLOT 0
- Number of inputs	1
- Connection	Two-conductor
- Type	NAMUR (DIN 19234)
- terminals marking	SLOT0 Terminals NAM- (1), NAM+ (2)
- Cable length	30 m max.
Note: The module installation is protected by a MID security mark.	
S0-SCR Interface module for ENCODER – SCR	
- Max. number of modules in the device	1
- Installation in the device	SLOT 0
- Number of inputs	1

- Connection	Two-wire
- Type	SCR+
- Communication protocol supported	OBIS 2005 (IEC 62056-21 Mode A) (EDIS (IEC1107 Mode A))
- Terminals marking	SLOT0 Terminals A (1), B (2)
- Cable length	30 m max.
Note: The module installation is protected by a MID security mark.	

### 3.10.2 Communication Modules

<b>S1-COM1 Communication module RS232/RS485</b>	
- Max. number of modules in the device	2
- Installation in the device	SLOT1, SLOT2
- Galvanic separation	Yes
- Serial communication interface	RS485 or RS232 (cannot be used simultaneously)
- Communication protocol	Selectable, depending on the firmware version (see Section 10)
- Communication speed	2 400 Bd to 115 200 Bd, adjustable
- Byte format	8 bits, 1 stop, no parity
<b>RS232 communication output</b>	
- Marking of the terminals	SLOT1,2 terminals GND (3), CTS (4), RxD (5), TxD (6)
- Connection via Ex i separator	B-RS module, or MTL5051
- Cable length	30 m max.
<b>RS485 communication output</b>	
- Marking of the terminals	SLOT1,2 terminals D+ (1), D- (2), GND (3), U+ (4)
- Connection via Ex i separator	B-RS module
- Max. cable length	100 m max.

<b>S4-COM0 RS232 communication module</b>	
- Max. number of modules in the device	1
- Installation in the device	SLOT 4
- Galvanic separation	yes
- Serial communication interface	RS232
- Communication protocol	Selectable, depending on the firmware version (see Section 10)
- Communication speed	2 400 Bd to 115 200 Bd, adjustable
- Byte format	8 bits, 1 stop, no parity

<b>RS232 communication output</b>	
- Marking of the terminals	RS232 terminals (GND, CTS, TxD, RxD)
- Connection via Exi separator	B-RS module, or MTL5051
- Cable length	30 m max.

<b>M2G internal 2G modem</b>	
- Max. number of modules in the device	1
- Device installation	SLOT 4 (battery powered) SLOT 5 (external power supply)
- Type of connection	2G modem, GSM/GPRS
- Frequency	Quad band 850/900/1800/1900 MHz
- Output power	Class 4 (2 W) for GSM 850 MHz, 900 MHz Class 1 (1 W) for GSM 1800 MHz, 1900 MHz
- Communication protocol	Selectable, depending on the firmware version (see Section 10)
- Required SIM card size	miniSIM
<b>Power supply of the modem module:</b>	
- Battery type	HB-03 (12 Ah) or HB-03D (20 Ah) battery
- Battery life - HB-03 HB-03D	6 years <sup>8)</sup> 11 years <sup>12)</sup>
- Battery voltage	3,0 V
- External power supply option	Yes
- Type of module for external power supply connection	S4-PWR2

<b>M4G internal modem LTE</b>	
- Max. number of modules in the device	1
- Device installation	SLOT 4 (battery powered) SLOT 5 (external power supply)
- Required SIM card size	miniSIM
<b>Versions of LTE modem</b>	
<b>Designation</b>	<b>M4G, LTE-Cat1E</b>
- Type of connection	LTE cat. 1, European design
- Frequency	800/900/1800/2100 MHz
- Output power	Class 4 (2 W) for GSM 900 MHz Class 1 (1 W) for GSM 1800 MHz Class 3 (23 dBm) for LTE 800, 900, 1800, 2100 MHz

<sup>8)</sup> The life of the battery depends on the set mode of the modem connection

<b>Designation</b>	<b>M4G, LTE-Cat1US</b>
- Type of connection	LTE cat. 1, American design
- Frequency	700/850/1700/1900 MHz
- Output power	Class 3 (+24 dBm) for UMTS 850, 1700, 1900 MHz Class 3 (+23 dBm) for LTE 700, 850, 1700, 1900 MHz
<b>Designation</b>	<b>M4G, LTE-CatM1US</b>
- Type of connection	LTE-M1, American design
- Frequency	700/1700/1900 MHz
- Output power	Class 3 (+23 dBm) for LTE 700, 1700, 1900 MHz
- Communication protocol	Selectable, depending on the firmware version (see section 10)
<b>Power supply of the modem module:</b>	
- Battery type	HB-04 (12Ah) battery
- Battery life	6 years <sup>12)</sup>
- Battery voltage	6V
- External power supply option	Yes
- Type of module for external power supply connection	S4-PWR2

### 3.10.3 Modules for Connecting External Power Supply

<b>S3-PWR1 module of EVC power supply</b>	
Max. number of modules in the device	1
- Installation in the device	SLOT3
- Module function	External power supply of the data logger circuits from an intrinsically safe PS-E source (does not power to M2G, M4G modems)
Galvanic separation	yes
Supply voltage	4,5 V – 6,5 V
Max. consumption	70 mA
Terminals marking	PWR1+, PWR1-
Cable length	30 m max. (min. conductor cross section 0.75 mm <sup>2</sup> see paragraph 5.5.6)
<b>S4-PWR2 module of external power supply of the internal modem</b>	
- Max. number of modules in the device	1
- Installation in the device	SLOT4
- Module function	External power supply of the of the M2G or M4G internal modem module from an intrinsically safe PS-M source
- Galvanic separation	yes
- Supply voltage	4,5 V – 6,2 V

- Max. consumption	1 A
- Terminals marking	PWR2+, PWR2-
- Cable length	see chapter 5.5.6 (depends on used cable cross section)

### 3.10.4 Analogue Inputs/Outputs Modules

#### S1-2AI Module of 4 – 20mA analogue inputs

- Max. number of modules in the device	2
- Installation in the device	SLOT 1, SLOT 2
- Number of module inputs	2
- Marking of the terminals	SLOT1,2 terminals GND (2), AI1 (3), GND (5), AI2 (6)
- Input options	4 – 20 mA current input (passive)
- Galvanic separation	No
- Cable length for each output	30 m max.

#### S1-2AO Module of 4 – 20mA analogue output

- Max. number of modules in the device	2
- Installation in the device	SLOT 1, SLOT 2
- Number of module inputs	2
- Marking of the terminals	SLOT1,2 terminals AO1- (2), AO1+ (3), AO2- (5), AO2+ (6)
- Output options	4 – 20 mA current output
- Galvanic separation	Yes (separation from the instrument and mutual separation both outputs apart)
- Power supply voltage	5 V – 28 V
- Cable length for each output	30 m max.

### 3.10.5 Other Modules

#### S0-EXT1 extension module

- Max. number of modules in the device	1
- Installation in the device	SLOT 0
<b>DIN-NAMUR digital inputs</b>	
- Number of digital inputs	2
- Input options DI1, DI2	HF NAMUR: 2 HF pulse inputs, or 1 HF pulse input of the gas meter with the option of detecting the rotation direction, or 2 binary inputs (NAMUR), or 2 NAMUR encoders
- Terminals marking	SLOT0 terminals DI1- (1), DI1+ (2), DI2- (5), DI2+ (6)

<b>DIN digital inputs</b>	
- Number of digital inputs	6
- Input options DI3 to DI8	LF inputs: 6 LF pulse inputs, or 3 LF pulse input of the gas meter with the option of detecting the rotation direction), or 6 binary inputs
- Terminals marking (DIN terminals)	GND, DI3 ,DI4 ,DI5 ,DI6 ,DI7 ,DI8 <sup>9)</sup>
- Cable length for each input	30 m max.
<b>AIN analogue inputs</b>	
- Number of analogue inputs	2
- Terminals marking (AIN terminal blocks)	AI1, AI2, GND <sup>9)</sup>
- Input options AI1, AI2	4 – 20 mA current input (passive)
- Cable length for each input	30m max.
<b>Inputs for digital transducers</b>	
- Number of inputs	2
- Terminals marking (IB1 terminal blocks)	GND, U+, D-, D+ <sup>9)</sup>
- Type of transducer	EDT 96, EDT 87
- Max. cable length (total length of both transducers)	100m max.
<b>BARP Module for measurement of barometric pressure</b>	
- Maximum number of modules in the device	1
- installation	optional <sup>*)</sup> – during production
<b>*) Warning:</b> The requirement to install the BARP module must be specified when ordering the device. The module will be installed during manufacturing of the device. The module cannot be installed by end user.	
- Barometric pressure measurement ranges	0.3 – 1.10 bar
- accuracy	± 2.5 mbar
<b>Remark:</b> The barometric pressure measurement module BARP is connected directly to the device's internal bus and does not reduce the number of connectable EDT xxx transducers to the device.	

<sup>9)</sup> The terminals are mounted on a special EXT1-T terminal board (KP100 160), which is connected with an extension module S0-EXT1 via cable (see Section 9, Fig. 63).

## 4 Explosion Safety Parameters

**DIN digital inputs:** (terminals DI1, GND, DI2, GND, DI3, GND, DI4, GND)

$U_o = 6.5 \text{ V}$

$I_o = 2 \text{ mA}$

$P_o = 3 \text{ mW}$

	IIB	IIA
Co	20 $\mu$ F	100 $\mu$ F
Lo	10mH	100mH

**DOOUT digital outputs:** (terminals U0+, GND0, DO1, DO2, DO3, DO4)

$U_i = 15 \text{ V}$

$I_i = 0.3 \text{ A}$

$\Sigma P_i = 0.5 \text{ W}$

$C_i = 3.3 \mu\text{F}$

$L_i = 0$

**IB0 and IB1 internal buses:** (terminals GND, U+, D-, D+)

$U_o = 6.5 \text{ V}$

$I_o = 2.2 \text{ A}$

$P_o = 1.1 \text{ W}$

	IIB	IIA
$\Sigma C_o$	24 $\mu$ F	50 $\mu$ F
$\Sigma L_o$ <sup>1/</sup>	1 $\mu$ H	1 $\mu$ H

<sup>1/</sup> inductive load, max. 100m cable can be connected

**KP 100 061 - SCR interface:** (SLOT 0 TERMINALS: A, B) <sup>2/</sup>

$U_o = 8.0 \text{ V}$

$I_o = 20 \text{ mA}$

$P_o = 160 \text{ mW}$

	IIB	IIA
Co	14 $\mu$ F	100 $\mu$ F
Lo <sup>3/</sup>	8 $\mu$ H	10 $\mu$ H

<sup>2/</sup> The module has an impact on the basic type of protection - see the instructions.

<sup>3/</sup> Inductive load, max. 30m cable can be connected.

**KP 100 062 - NAMUR interface:** (SLOT 0 TERMINALS: NAMUR+, NAMUR-)

$U_o = 10.0 \text{ V}$

$I_o = 11 \text{ mA}$

$P_o = 27 \text{ mW}$

	IIB	IIA
Co	20 $\mu\text{F}$	20 $\mu\text{F}$
Lo	1 mH	1 mH

23

**KP 100 110 - RS485 interface:** (SLOT 1,2 TERMINALS: D+, D-, GND, U+)

$U_i = 10 \text{ V}$

$I_i = 0.15 \text{ A}$

$\Sigma P_i = 0.33 \text{ W}$

$C_i = 4 \mu\text{F}$

$L_i = 0$

**KP 100 110 - RS232 interface:** (SLOT 1,2 TERMINALS: GND, CTS, RXD, TXD)

$U_i = 20 \text{ V}$

$I_i = 0.15 \text{ A}$

$\Sigma P_i = 0.46 \text{ W}$

$C_i = 1 \mu\text{F}$

$L_i = 0$

**KP 100 121 - PWR1 external power supply:**(SLOT 3, terminals PWR1+, PWR1 - )

$U_i = 6.5 \text{ V}$

$I_i = 0.2 \text{ A}$

$P_i = 0.41 \text{ W}$

$C_i = 40 \mu\text{F}$

$L_i = 1.1 \text{ mH}$

**KP 100 140 - PWR2 external power supply:** (SLOT 4, terminals PWR2+, PWR2 - ) <sup>2/</sup>

$U_i = 6.2 \text{ V}$

$I_i = 1 \text{ A}$

$P_i = 6.2 \text{ W}$

$C_i = 13 \text{ mF}$

$L_i = 55 \text{ }\mu\text{H}$

<sup>2/</sup> The module has an impact on the basic type of protection - see the instructions.

**KP 100 112 - AIN analogue inputs:** (SLOT 1,2 TERMINALS: GND, AI1, GND, AI2) <sup>4/</sup>

$U_i = 28 \text{ V}$

$I_i = 93 \text{ mA}$

$P_i = 0,66 \text{ W}$

$C_i = 40 \text{ nF}$

$L_i = 0$

<sup>4/</sup> Inputs are passive.

**KP 100 113 - AO analogue outputs:** (SLOT 1,2 TERMINALS: AO1+, AO1-, AO2+, AO2-)

$U_i = 28 \text{ V}$

$I_i = 0.1 \text{ A}$

$P_i = 0.66 \text{ W}$

$C_i = 0.46 \text{ }\mu\text{F}$

$L_i = 0$

**EXT1 board (KP 100 130) - DI1, DI2 (NAMUR):** (SLOT 0 TERMINALS: DI1-,DI1+,DI2-,DI2+)

$U_o = 10,0 \text{ V}$

$I_o = 11 \text{ mA}$

$P_o = 27 \text{ mW}$

	IIB	IIA
Co	20 $\mu\text{F}$	100 $\mu\text{F}$
Lo	1 mH	1 mH

**EXT1 board (KP 100 130) - DI3 to DI8:** (terminals: GND, DI3,DI4, DI5, DI6, DI7, DI8)

$U_o = 6.5 \text{ V}$

$I_o = 2 \text{ mA}$

$P_o = 3 \text{ mW}$

	IIB	IIA
Co	20 $\mu\text{F}$	100 $\mu\text{F}$
Lo	10 mH	100 mH

---

 25
 

---

**EXT1 board (KP 100 130) - AIN analogue inputs:** (terminals: GND, AI1, GND, AI2) <sup>4/</sup>

$U_i = 28 \text{ V}$

$I_i = 93 \text{ mA}$

$P_i = 0.66 \text{ W}$

$C_i = 40 \text{ nF}$

$L_i = 0$

<sup>4/</sup> Inputs are passive.

## 5 Installation and Commissioning

The data logger is a compact device built into a plastic enclosure with IP66 protection rating. The device is intended for installation in potentially explosive atmospheres. It has been approved for either ZONE 0 or ZONE 1 environment, depending on the specific modules installed in the device, as specified in Section 1.

In addition to completely enclosed electronics, the enclosure contains power supply batteries and a digital pressure transducer with M12x1.5 threaded joint according to DIN W 3861 for connecting a pressure pipe.

At the bottom of the cabinet are metal cable glands for connecting the input and output signal cables with the possibility to connect the cable shielding conductively.

### 5.1 Dimensions of the Device

#### 5.1.1 Prilog 400 data logger

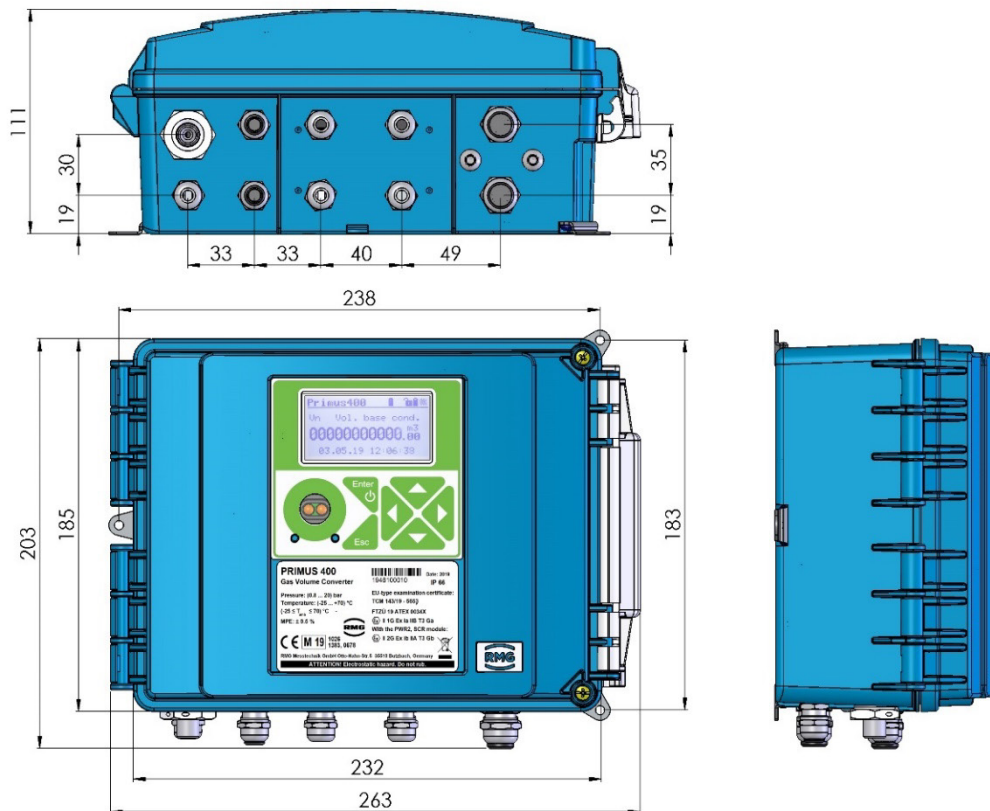

Fig. 1: Prilog 400 dimensions

## 5.2 Security Marks of the Device

Broken security marks indicate unauthorized manipulation of the device.

### Security Mark MessEG (Metrological Seal)

Its form is prescribed by the certificate for Quality Management System for Production, Output Control and Testing according to Annex No 2, Procedure D, NV 120/2016 Coll., issued by Notified Body No 1383.

According to the German Verification Act there is a validation period for the Prilog 400 of 8 years.

When this mark is breached, the manufacturer cannot guarantee that the device features are in compliance with the MessEG type-examination certificate.

### Manufacturer's Seal (Warranty Seal)

Inspection mark of the manufacturer according to the manufacturer's needs to ensure the warranty.

### User Mark

Inspection mark (seal) of the user according to the user's needs.

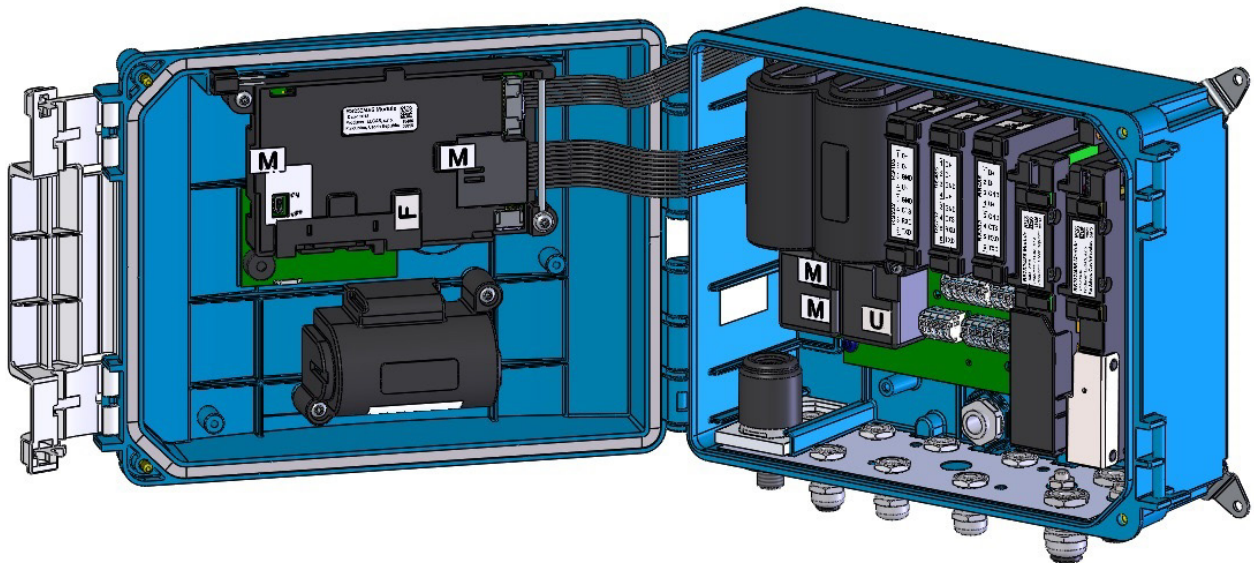





Fig. 2: Internal security marks of Prilog 400

<b>M</b>	Metrological seal	
<b>F</b>	Warranty seal	
<b>U</b>	User mark	

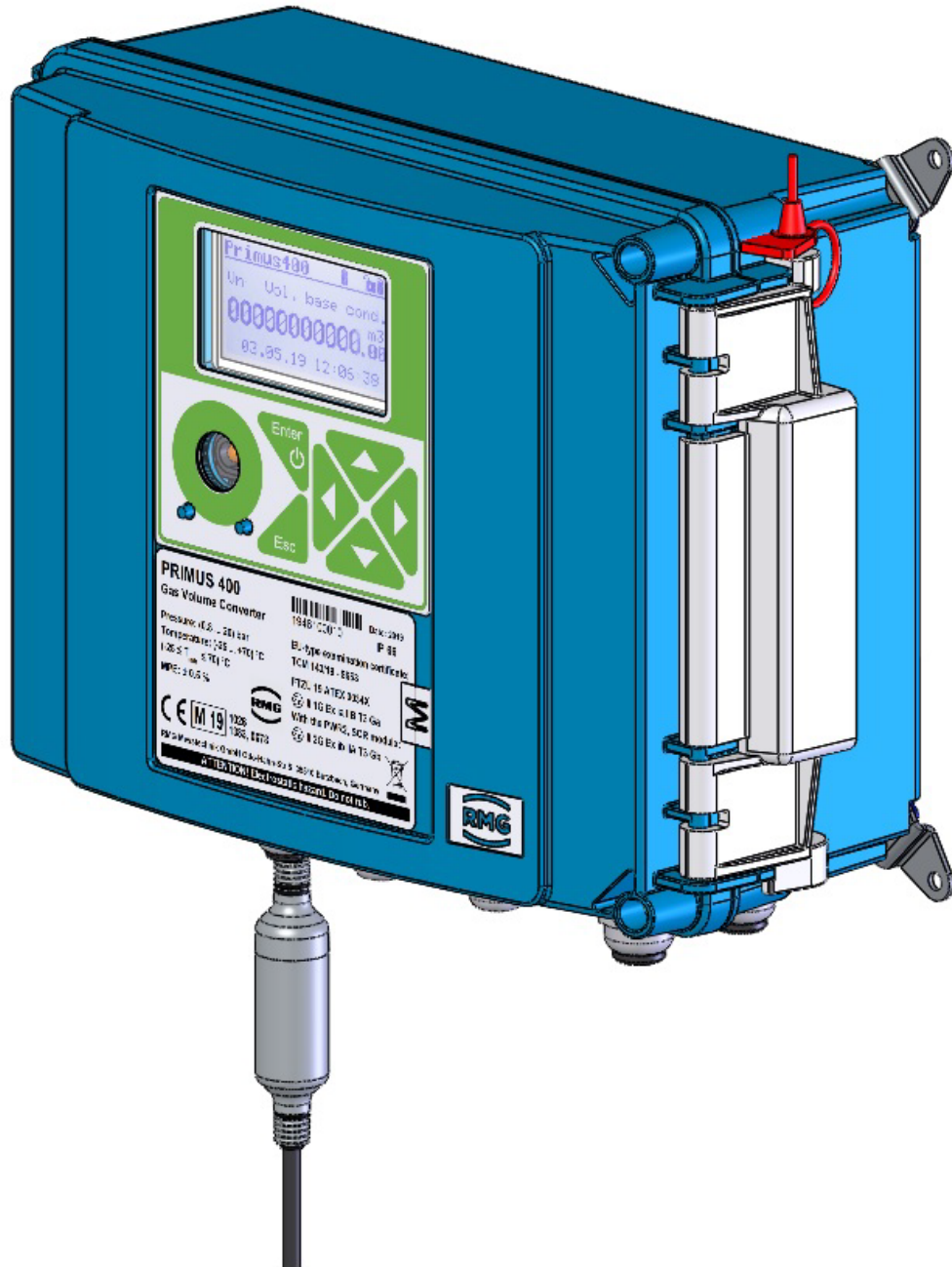

Fig. 3: External security marks of the device

<b>M</b>	Metrological seal	
----------	-------------------	--

### 5.3 Example for Data Plate

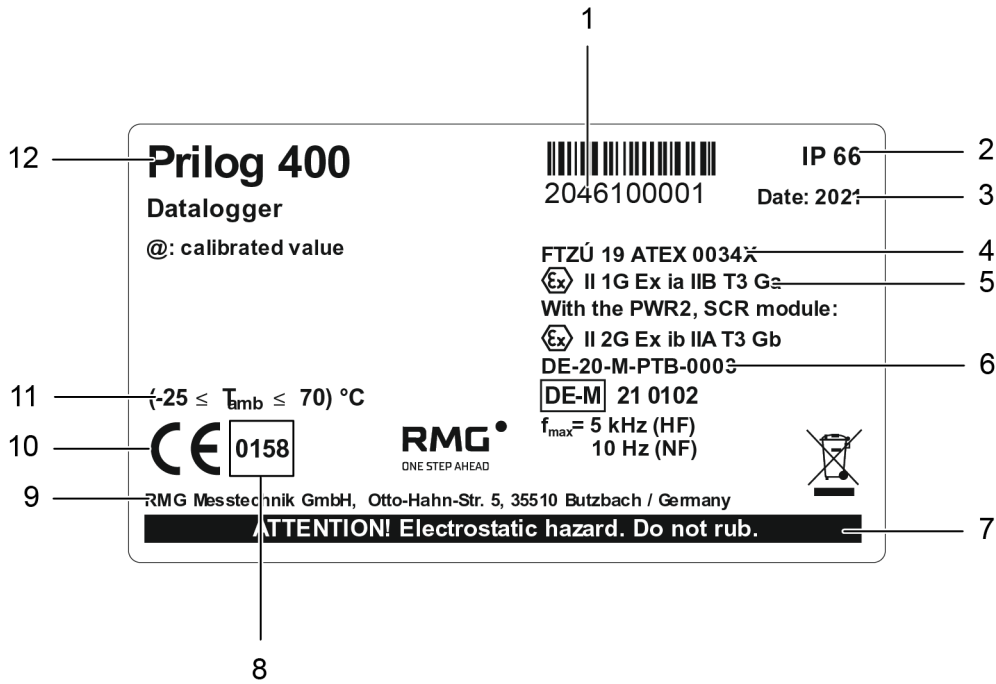

Fig. 4: Data plate (for example)

Item	Designation	Item	Designation
1	Serial number of the device	7	Warning to operators
2	IP rating	8	Notified body designation
3	Year of manufacture	9	Manufacturer's address
4	EU Type examination certificate (ATEX)	10	CE conformity mark
5	Explosion protection designation	11	Ambient temperature range
6	MessEG Type examination certificate (metrological)	12	Device designation

## 5.4 Mechanical Installation

The device is intended for mounting on a wall or on a pipe by means of a mounting plate. In the case of pipe mounting, special holders can also be used instead of the standard mounting plate.

The device is mounted on the mounting plate first. If the pressure transducer in the device is required to be connected via a 3-way ball valve, the 3-way ball valve can also be placed on this mounting plate. The mounting plate has been designed to be fitted with three-way valves supplied by RMG. The equipped mounting plate can be attached by means of screws and dowels to the wall, or by means of two clamps with locking devices on horizontal or vertical piping.

### ⚠ Caution

The data logger is a legally controlled technical equipment that is subject to government professional supervision (in Germany).

**The device may be installed by only a qualified person holding a certificate of professional competence issued by a government body of labour safety supervision.**

A person meeting the above conditions must also hold a "Certificate of completion of professional training" for the installation and operation of the given type of equipment. Such certificate is usually issued by the device manufacturer or an authorized partner on the basis of the training provided.

Failure to comply with these requirements gives rise to a risk of breach of warranty conditions.

### ⚠ Caution

The Prilog 400 data logger is classified under the Metrology Act as being in the category of approved measuring instruments. Entities intending to carry out the installation of approved measuring instruments in Germany or countries with special approval are obliged to obey the national laws and rules concerning Metrology.

### ⚠ Caution

The device is available in various models to be used in ZONE 1 or ZONE 0 environment. The model designated for ZONE 1 must not be used in ZONE 0 environment.

**The device may be operated in ZONE 0 only on condition that the "II 1G" category is indicated on data plate of the device in the ATEX label.**

Before installing the device to ZONE 0, make sure that the "II 1G" category is indicated in the ATEX label.

### Note

**The device display and the visor for the optical head are protected from scratching by a transparent protective foil. Remove the protective foils after installation (they may impair the readability of the display and the functionality of the optical head).**

**Note**

**Potential damage caused by prolonged direct sunlight on the device!**

Prolonged direct sunlight on the device can cause the display to fail and lead to premature ageing of the plastic housing. Install the device in a location that is not exposed to prolonged direct sunlight or use suitable protective covers.

**5.4.1 Mounting the Device on the Plate**

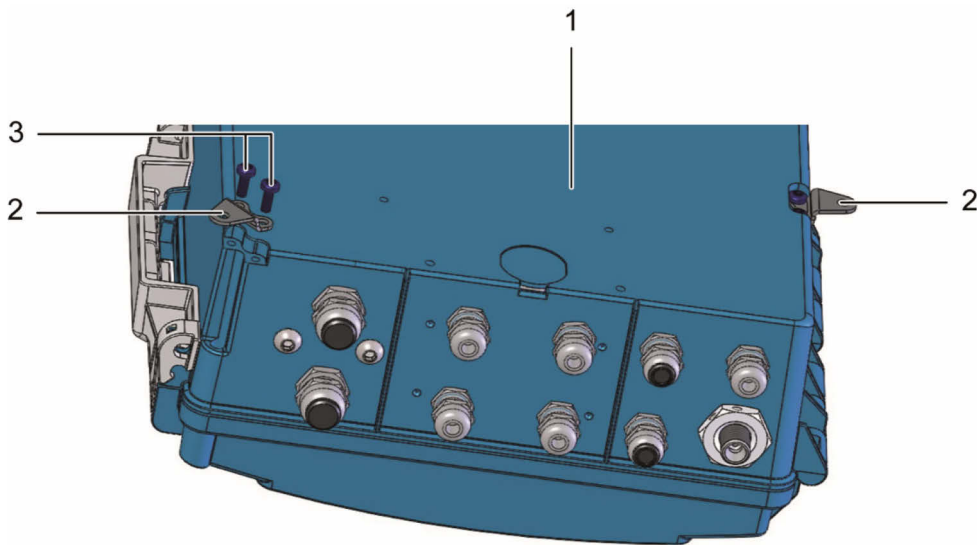

*Fig. 5: Mounting the brackets on the device*

Item	Designation	Item	Designation
1	Bottom plate of device	3	Self-tapping screws for plastic 3.5x12
2	Brackets		

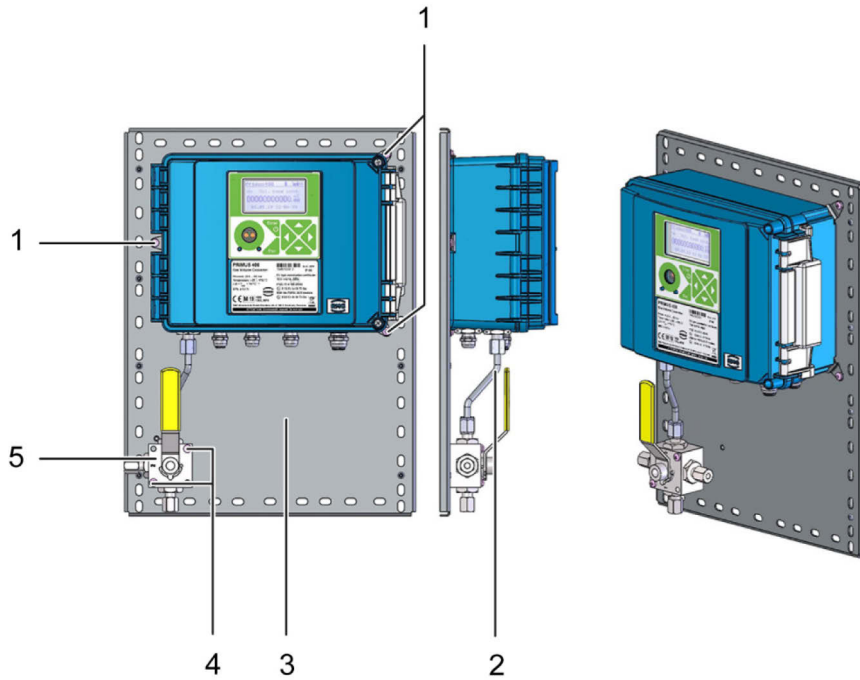

Fig. 6: Mounting Prilog 400 on a mounting plate

Item	Designation	Item	Designation
1	M4x10 screws to ISO 7045	4	M4x40 screws to ISO 7045
2	Pressure line with 6 mm connection	5	3-way ball valve
3	Mounting plate		

**Procedure:**

1. Before attaching the device to the mounting plate (fig. 6, item 3), first fit 3 pcs of brackets (fig. 5, item 2) using 3.5x12 self-tapping screws for plastic (fig. 5, item 3) supplied with the device onto the bottom side of the device (fig. 5, item 1).
2. Attach the device fitted with brackets to the mounting plate (fig. 6, item 3) using 3 screws M4x10 ISO 7045 (fig. 6, item 1). The M4 rivet nuts are pre-fitted on the mounting plate.
3. Attach a 6 mm connection pressure tube (fig. 6, item 2) to the pressure sensor in the bottom of the cabinet to connect the 3-way ball valve. To attach the tube to the pressure sensor, use a cutting ring with M12x1.5 ERMETO nut.
4. Attach a three-way tap (fig. 6, item 5) to the mounting plate using 2 screws M4x40 ISO 7045 (fig. 6, item 4). Check that the pins and the position of the three-way tap control lever are correctly oriented before installation. Connect the free end of the connection tube to the three-way valve outlet (for more details, refer to Section 5.4.3).
5. Check the tightness of the connections.

Mounting plate designation	Designed for device	Size [mm]	Note
KP 108 85	Prilog 400	300 x 250	For mounting without 3-way valve
KP 108 88	Prilog 400	300 x 400	Allows for mounting up to 2 pcs of 3-way valve

Table 1: Mounting plates supplied

5.4.2 Mounting the Device on a Pipe

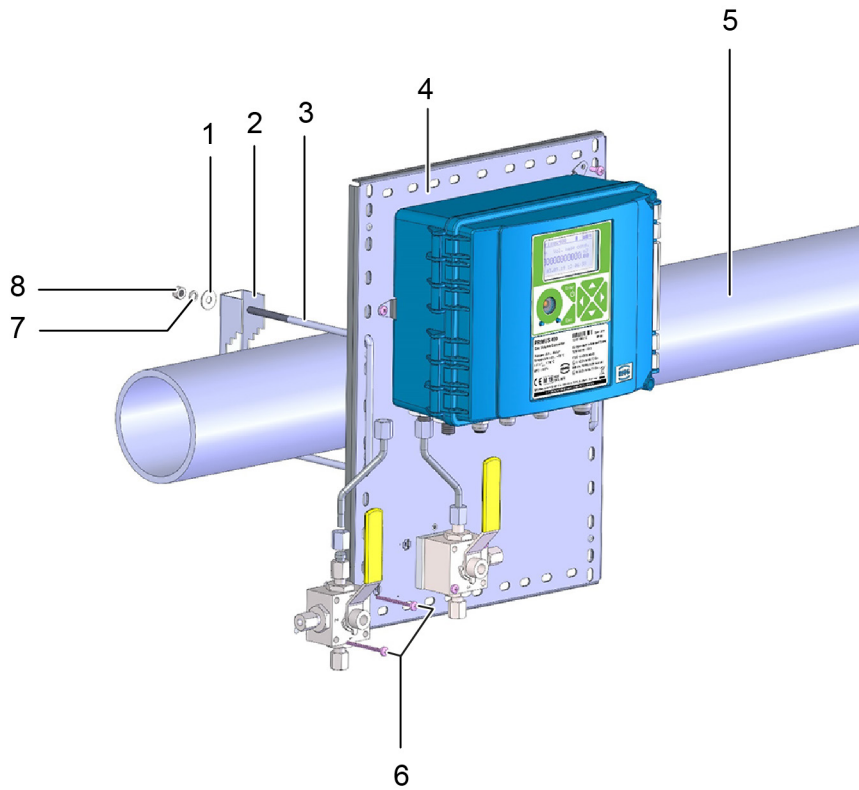

Fig. 7: Mounting the device on a pipe

Item	Designation	Item	Designation
1	Washer	5	Gas pipe
2	Fasteners	6	M4x40 screws to ISO 7045
3	Clamps	7	Washer
4	Mounting plate	8	Nut M6

Procedure:

1. Insert the clamps (fig. 7, item 3) with spacings corresponding to the pipe diameters through the openings in the mounting plate (fig. 7, item 4) and guide them over the gas pipe (fig. 7, item 5).
2. Attach fasteners (fig. 7, item 2) with washers (fig. 7, items 1 and 7) and M6 nuts (fig. 7, item 8) to the free ends of the clamps in order to fix the mounting plate in the intended position on the gas pipe.

The mounting plate can be used for fixing to a pipe of diameter:

- DN80 - DN200 for horizontal piping, or
- DN80 - DN150 for vertical piping.

For installation on piping or on RMG gas meters special holders shown on fig. 8 can also be used.

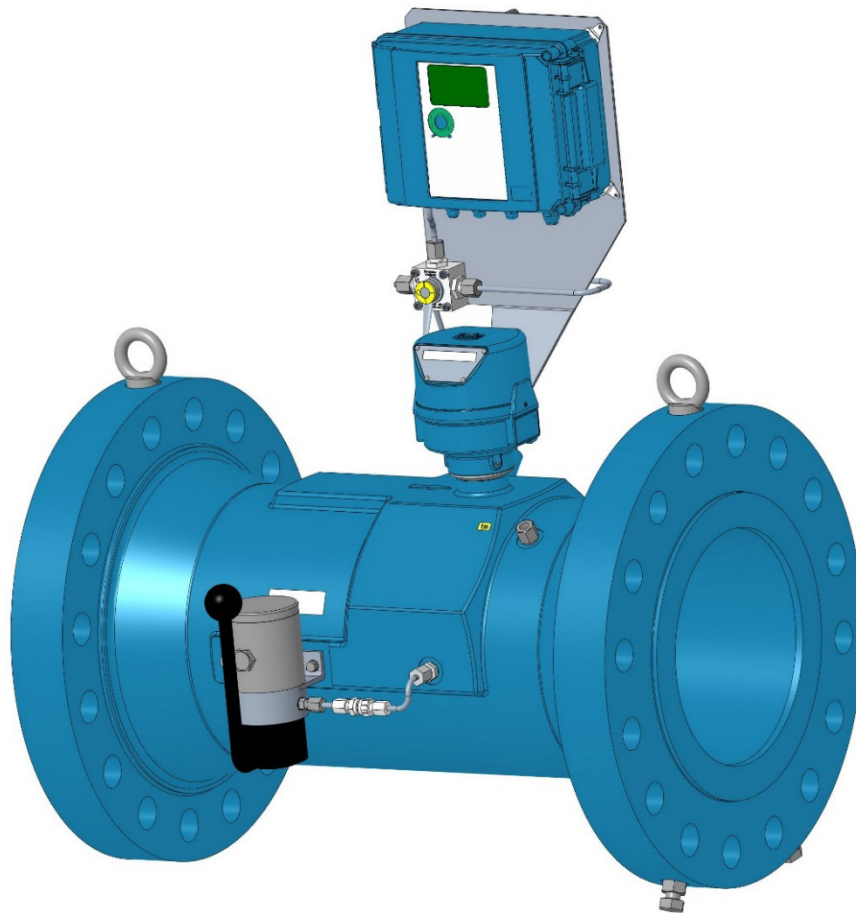

Fig. 8: Installation of Prilog 400 on RMG turbine gas meter

### 5.4.3 Connecting the Pressure Transducer

To connect the pressure transducer or the 3-way valve, we recommend using precision seamless 6x1mm stainless steel pipes or approved (for the maximum operating pressure) plastic hoses fitted with suitable end caps. The measured pressure comes from the gas pipe from the Pm outlet (former Pr) on the gas meter body.

The data logger connected via the 3-way valve is shown in fig. 7. Pressure tube 6x1 with cutting ring pre-pressed on both sides is first thoroughly inserted into the pressure inlet of the device and secured with M12x1,5 ERMETO nut. The other end of the tube is attached to the 3-way valve working outlet fitted on the mounting plate and the nut is gently tightened. The last operation is tightening the nuts on both sides of the connecting pressure pipe. Excessive force must not be applied when tightening the key, otherwise the thread will be damaged.

### 5.4.4 Connecting the Temperature Transducer

Connecting the temperature transducer by means of a thermowell fitted on the gas meter is the standard method of connection. If no thermowell is fitted on the gas meter, a weld-on fitting for mounting the thermowell is welded according to the gas meter manufacturer's instructions, usually in the outlet pipe of the gas meter. The permitted distance to the gas meter is to be taken from the installation instructions of the gas meter or from the corresponding technical guidelines.

The weld-on fitting must be welded in such a way that the thermowell is in the vertical position, or inclined under 45° angle from the vertical axis with the cavity up (fig. 9). Into the weld-on fitting, a thermowell of the appropriate length for the used pipe diameter is screwed over a copper gasket (see table 2). The metal shank of the temperature transducer is inserted thoroughly into the thermowell and secured by a locknut. The maximum axial load of the temperature transducer cable is 50N.

Before inserting the sensor shank into the thermowell, it is recommended that the space around the shank inside the thermowell is filled with silicone oil or that the shank is lubricated with silicone grease for better heat transfer to the temperature sensor.

DN (mm)	L – Thermowell (mm)	Weld-on fitting
40	55	inclined
50	55	straight
80	100	inclined
100	100	straight
150	160	inclined
>200	160	straight

Table 2: Weld-on fittings and thermowells appropriate for the pipe diameters

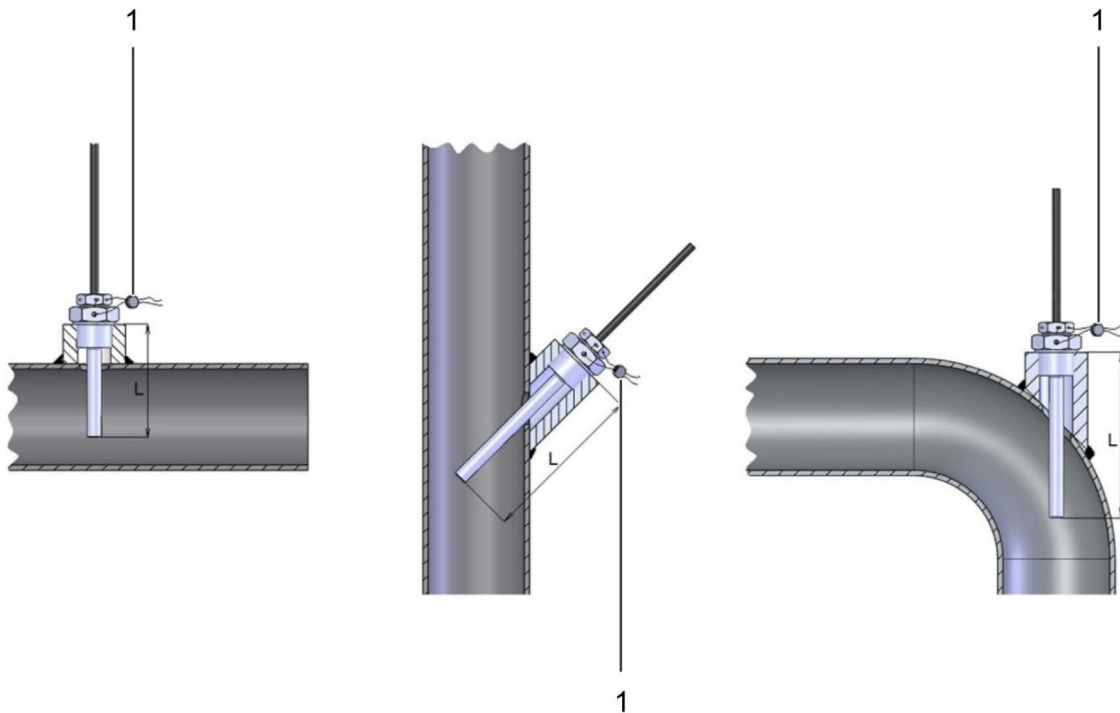

Fig. 9: Mounting the temperature sensor on the pipe

Item	Designation	Item	Designation
1	User seal		

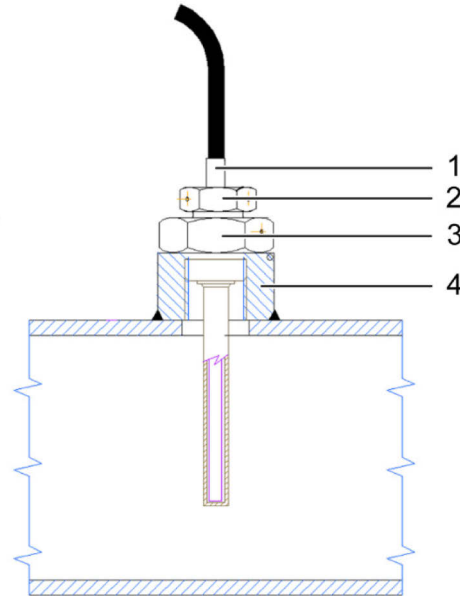

Fig. 10: Mounting the temperature sensor using a straight weld-on fitting

Item	Designation	Item	Designation
1	Temperature transducer	3	Thermowell
2	Locknut	4	Straight weld-on fitting

## 5.5 Electrical Connection

The text below describes electrical connection of the data logger with other devices. For the described connections to work properly, the device must be set correctly up. The device can be set up either using the operating software [19] or from the device keypad (see Section 6.7).

### 5.5.1 Connecting Cables

**⚠ Caution**

**Always use shielded cables complying with the standard [5] to connect the device to other devices.**

**On the device side, the shields of all the connected cables must be connected to the metal body of the cable gland according to fig. 11.**

**When installing the device and connecting the cable shields, make sure that ground loops are not created.**

All the cable glands in the device are electrically interconnected, the shields of all the cables entering the device are therefore connected at this point. This ensures high resistance to electromagnetic interference.

The following applies:

- For the digital pressure transducer (i.e. built into body of the device housing), the metal housing of the transducer is conductively connected with the metal cable glands of the device, i.e. with the shielding of the cables fixed in the cable glands of the device.
- The temperature transducer and the external digital pressure transducer (if installed) are to be connected to the device with a shielded cable whose shield is connected to the metal body of the cable gland.
- The metal shank of the temperature transducer is insulated from the shield of the cable and all other parts of the device.
- The metal body of the external pressure transducer is to be connected to the cable shield.

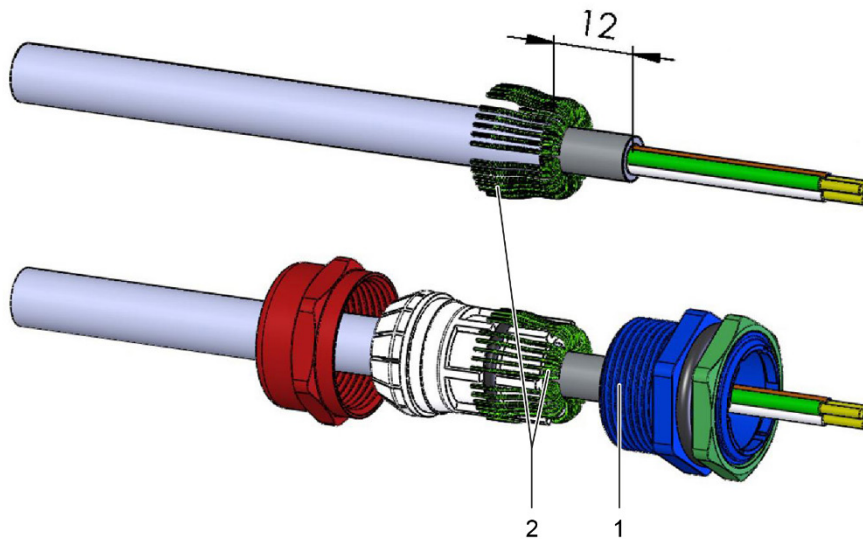

Fig. 11: Connecting the cable shields in the cable glands

Item	Designation	Item	Designation
1	Metall body of cable gland	2	Cable shields

**Note**

The device is equipped with metal cable glands size PG7 and PG9. These glands are designed for cables of the following diameters:

PG7	3.0 – 6.5 mm
PG9	4.0 – 8.0 mm

The cable glands are arranged as shown in fig. 12.

The minimum cross section is specified for the recommended shielded cables listed below. When using larger cross sections, it is necessary to check that the cable diameter matches the used cable gland.

### ⚠ Caution

**Unused cable glands must be sealed with a stopper plug.**

When supplied, stopper plugs are mounted in all unused cable entries.

38

### Note

Terminals for connecting cables allow to connect conductors with a cross section of  $0.5 \text{ mm}^2$  –  $2.0 \text{ mm}^2$  (20 AWG – 14 AWG).

**Before connecting the cables, it is necessary to attach a cable sleeve to each stripped end of a cable and press the sleeves with pliers recommended by the sleeve manufacturer.**

Cables terminated with sleeves can be inserted into the terminals without any tool, while taking the cable out requires a slight push on the clamp pin and slightly pulling the cable out.

Temperature ranges for recommended UNITRONIC LiYCY cables according to the manufacturer:

- Fixed mounting:  $-40^\circ\text{C}$  –  $+80^\circ\text{C}$
- Occasional mobile use:  $-5^\circ\text{C}$  -  $+70^\circ\text{C}$

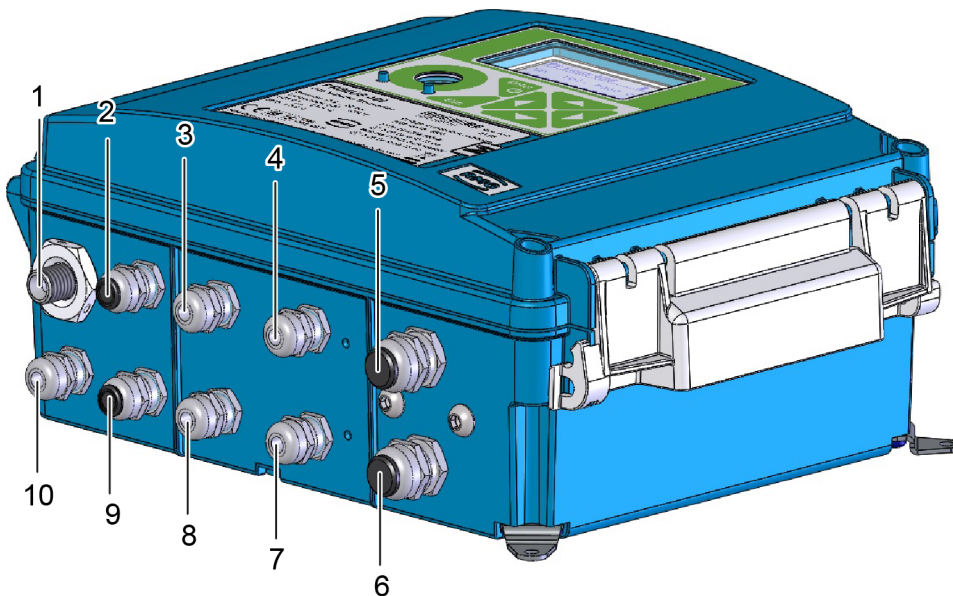

Fig. 12: Cable glands arrangement

Item	Cable	Size	Item	Cable	Size
1	Pressure (1st channel)	PG7	6	External power supply for the device and the modem	PG9 for Ex zone 0 and 1/ M20x1,5 for Ex zone 2
2	Gas meter (1st channel)	PG7	7	External pressure (2nd channel)	PG7
3	Gas meter (2nd channel), digital inputs (DIN)	PG7	8	Temperature (2nd channel)	PG7
4	Communication	PG7	9	HF gas meter, encoder	PG7
5	Digital output (DOU), communication	PG9	10	Temperature (1st channel)	PG7

Table 3: Cable entries - recommended use

### 5.5.1.1 Opening and Closing the Device

To open the device:

- Loosen the screws (item 2).
- Open the catch (item 1).

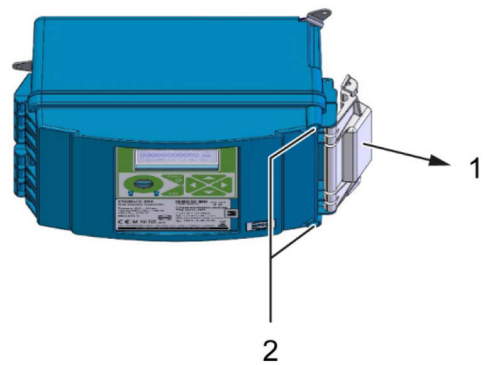

To close the device:

- Close the catch (item 1).
- Tighten the screws (item 2).  
Specified tightening torque of the cover bolts is 0.5 to 0.7 Nm.

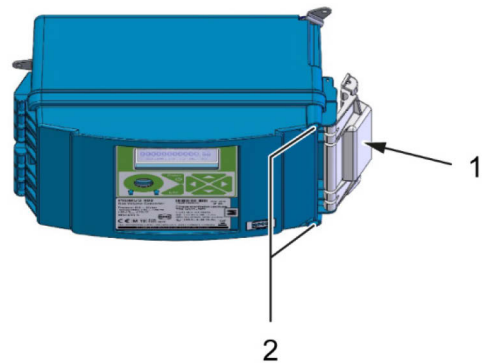

### 5.5.1.2 Locking and Sealing the Device

The clamp of the device cover can be secured with plastic or wire seal (item 1) and locked with a padlock (item 2) with the shackle diameter of up to 5 mm.

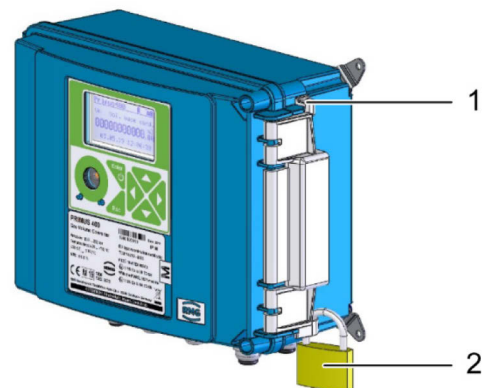

## 5.5.2 Connecting Gas Meters

### Gas meters with LF pulse output

DIN terminal block is the standard for a LF gas meter connection. The Prilog 400 device is a single channel unit. The DIN terminal block is hidden under a plastic cap that the users can secure with their mark.

40

Prilog 400 – LF gas meter	
1st channel	
Terminal	Connection
DI1	Pulse output of the gas meter
DI4	- Contact for the gas meter connection monitoring (tamper contact), or - Pulse output of the gas meter for detecting the rotation direction
2nd channel	
Terminal	Connection
DI2	Pulse output of the gas meter
DI3	- Contact for the gas meter connection monitoring (tamper contact), or - Pulse output of the gas meter for detecting the rotation direction

### Gas Meters with HF Pulse Output

**Prilog 400** – To connect the device, the EXT1 module must be installed in the SLOT 0 position. The EXT1 module allows for connecting either one HF gas meter with the detection of rotation direction or two HF gas meters. The meter is connected by means of terminals 1 and 2; to terminals 5 and 6, either auxiliary gas meter sensor with the detection of rotation direction or another HF gas meter can be connected.

#### Warning

**When using a HF meter, the data logger must be powered from an external intrinsically safe power supply (eg PS-E, PS-E/A).**

**Gas Meter with NAMUR or SCR Encoder**

**Prilog 400** – The module of the interface of the encoder must be fitted in the SLOT 0 position. The gas meter is connected to terminals 1 and 2. The external power supply of the data logger is not necessary.

Connection	Cable	Entry	Recommended type of cable	Cable Ø
Pulse input (both LF and HV gas meter), encoder	2-wire shielded	PG7	Unitronic LiYCY 2 x 0.25 Lappkabel	4.5 mm
Pulse input with tamper contact	4-wire shielded	PG7	Unitronic LiYCY 4 x 0.25 Lappkabel	5.0 mm
Pulse input with the detection of rotation detection	4-wire shielded	PG7	Unitronic LiYCY 4 x 0.25 Lappkabel	5.0 mm

Table 4: Cables recommended to connect the gas meter

**5.5.2.1 LF Gas Meter, Single Channel data logger**

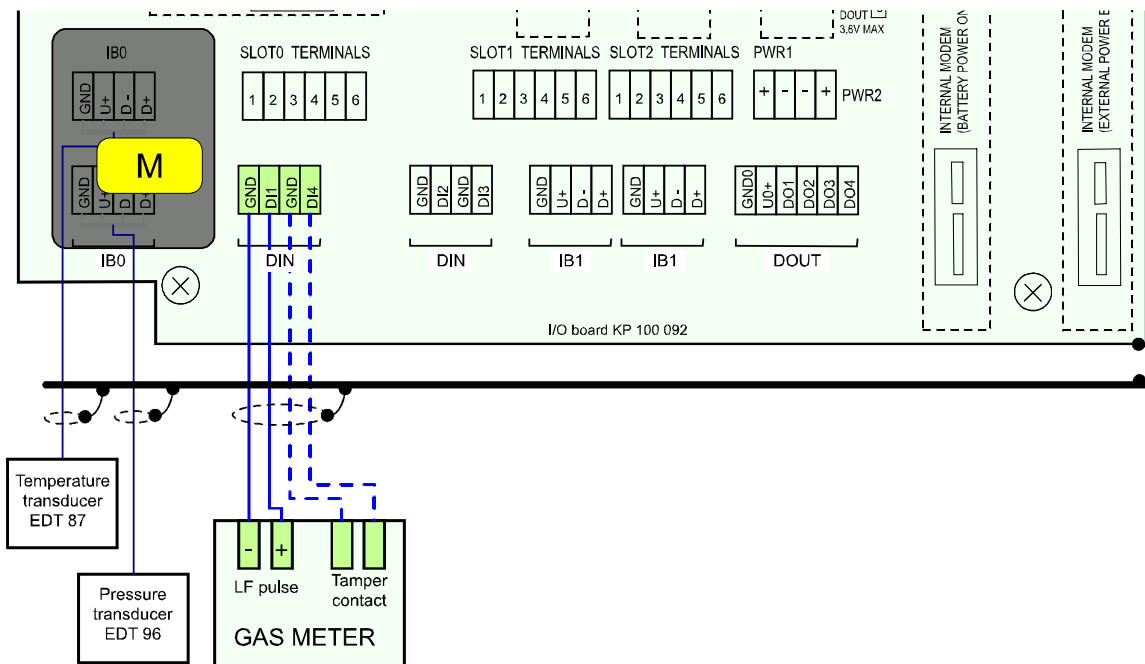

Fig. 13: Connecting LF gas meter to Prilog 400 (single channel)

5.5.2.2 LF Gas Meter with the Detection of Rotation Direction

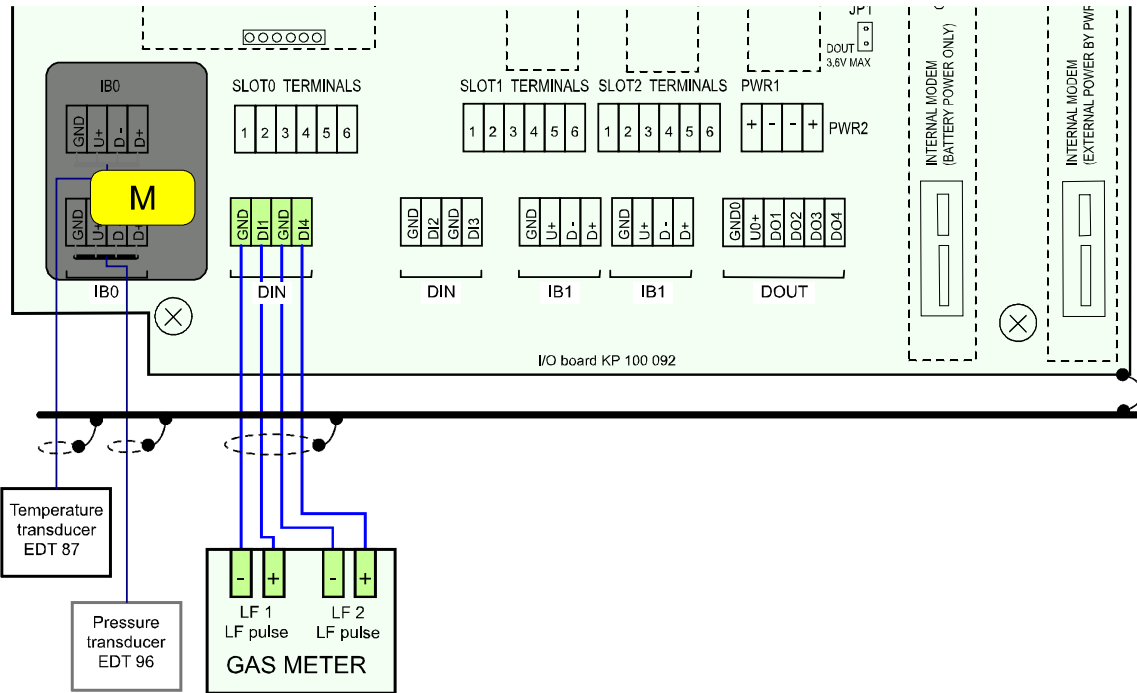

Fig. 14: Connecting LF gas meter with the detection of rotation direction to Prilog 400

5.5.2.3 HF Gas Meter, optionally with Encoder

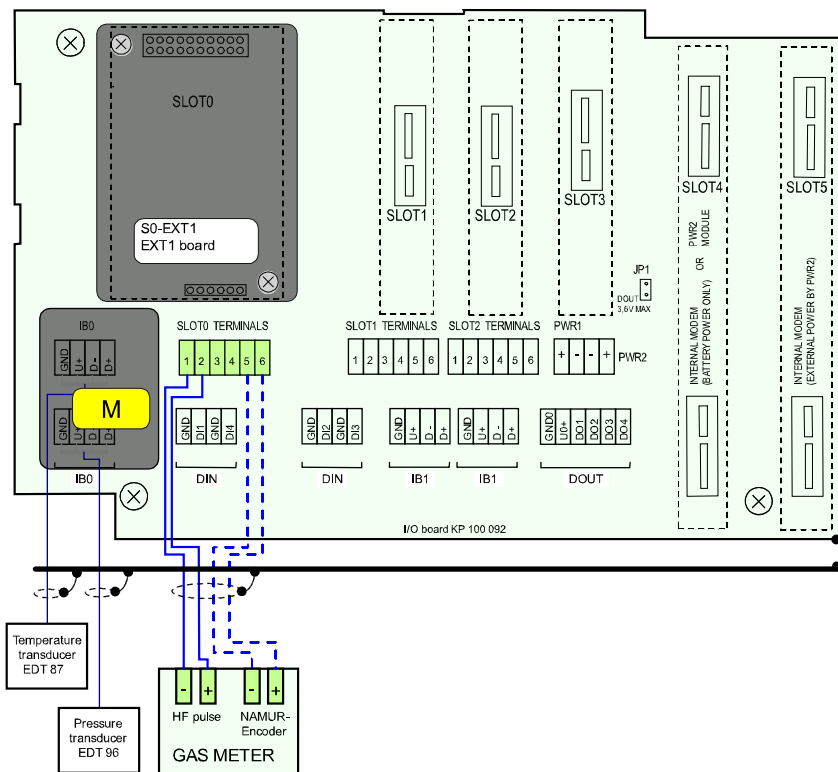

Fig. 15: Connecting HF gas meters (optionally with encoder) to Prilog 400

5.5.2.4 Gas Meter with Encoder

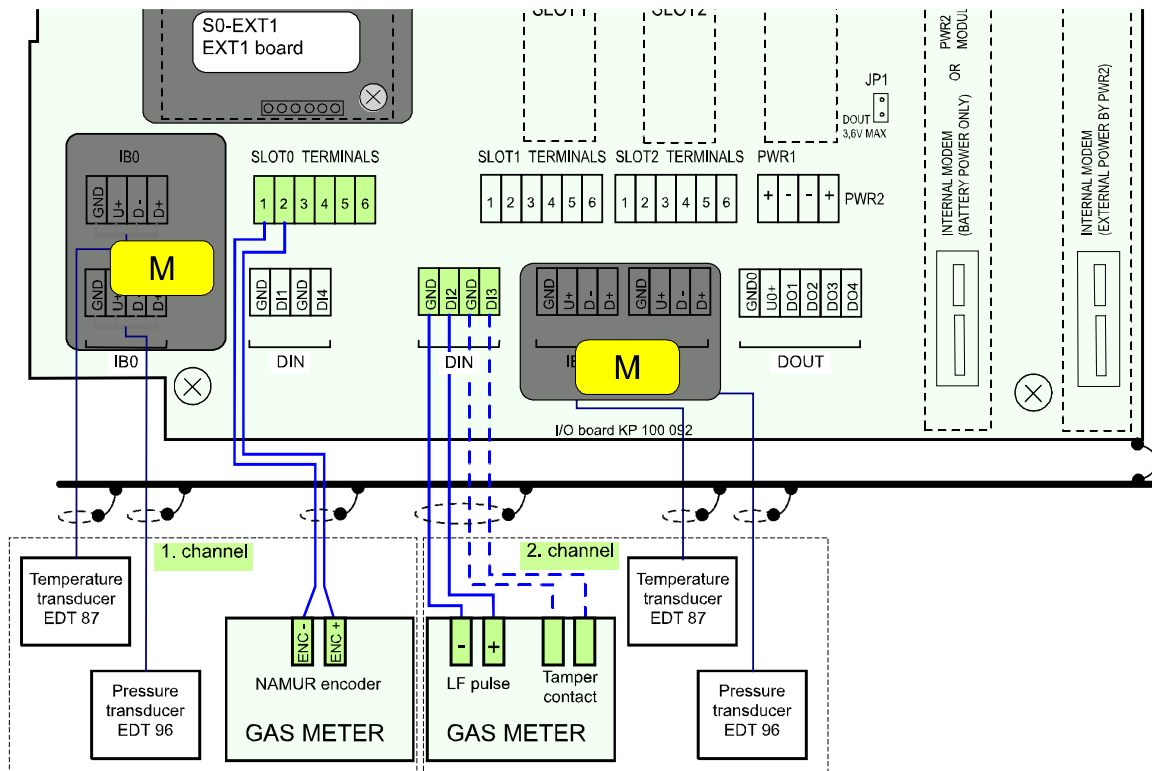

Fig. 16: Connecting gas meter with NAMUR encoder to Prilog 400

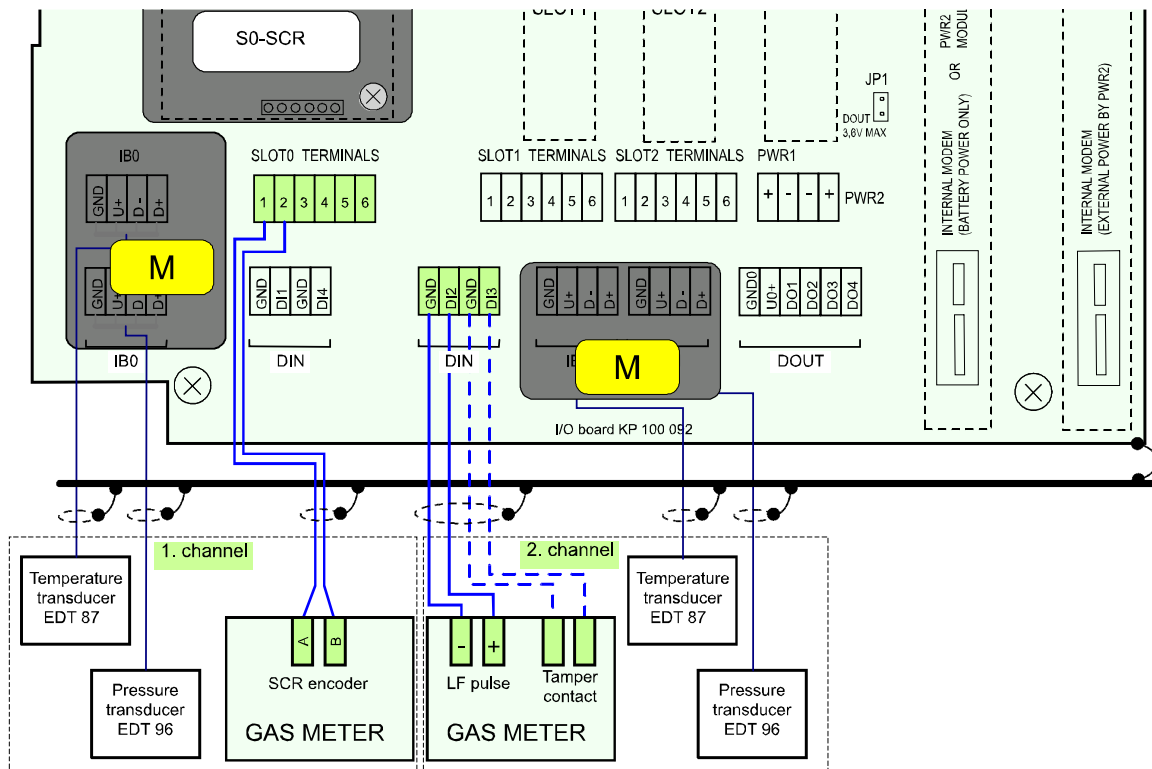

Fig. 17: Connecting gas meter with SCR encoder to Prilog 400

### 5.5.3 Connecting Binary Inputs

**Prilog 400** – One of the free terminals DI1 to DI4 can be used to connect binary inputs, if they have not been used to connect the gas meter.

44

#### **⚠ Caution**

Signals on all digital inputs (DIN terminals) are intrinsically safe. The sensors connected to these terminals must be:

- Either intrinsically safe with the corresponding Ex-I parameters,
- Or they must fall under the “Simple Device” category according to [2],
- Or they must be connected via a safety barrier.

Connection	Cable	Entry	Recommended type of cable	Cable Ø
Binary input (single)	2-wire shielded	PG7	Unitronic LiYCY 2 x 0.25 Lappkabel	4.5 mm
Binary input (double)	3-wire shielded	PG7	Unitronic LiYCY 3 x 0.25 Lappkabel	4.7 mm
Binary input (triple)	4-wire shielded	PG7	Unitronic LiYCY 4 x 0.25 Lappkabel	5.0 mm
Binary input (four times)	5-wire shielded	PG 7	Unitronic LiYCY 5 x 0.25 Lappkabel	5.6 mm

Table 5: Cables recommended to connect binary inputs

### 5.5.4 Connecting Digital Outputs

**Prilog 400** – with 4 digital outputs available, DO1 to DO4 terminals on the DOUT terminal block.

#### **⚠ Caution**

The signals of the DOUT terminal block are intrinsically safe, which is why common devices must be connected via a separation safety barrier (B-DO module).

Connection	Cable	Entry	Recommended type of cable	Cable Ø
Digital output (single)	3-wire shielded	PG7	Unitronic LiYCY 3 x 0.25 Lappkabel	4.7 mm
Digital output (four times)	6-wire shielded	PG7	Unitronic LiYCY 6 x 0.25 Lappkabel	6.0 mm

Table 6: Cables recommended to connect binary outputs to the B-DO module

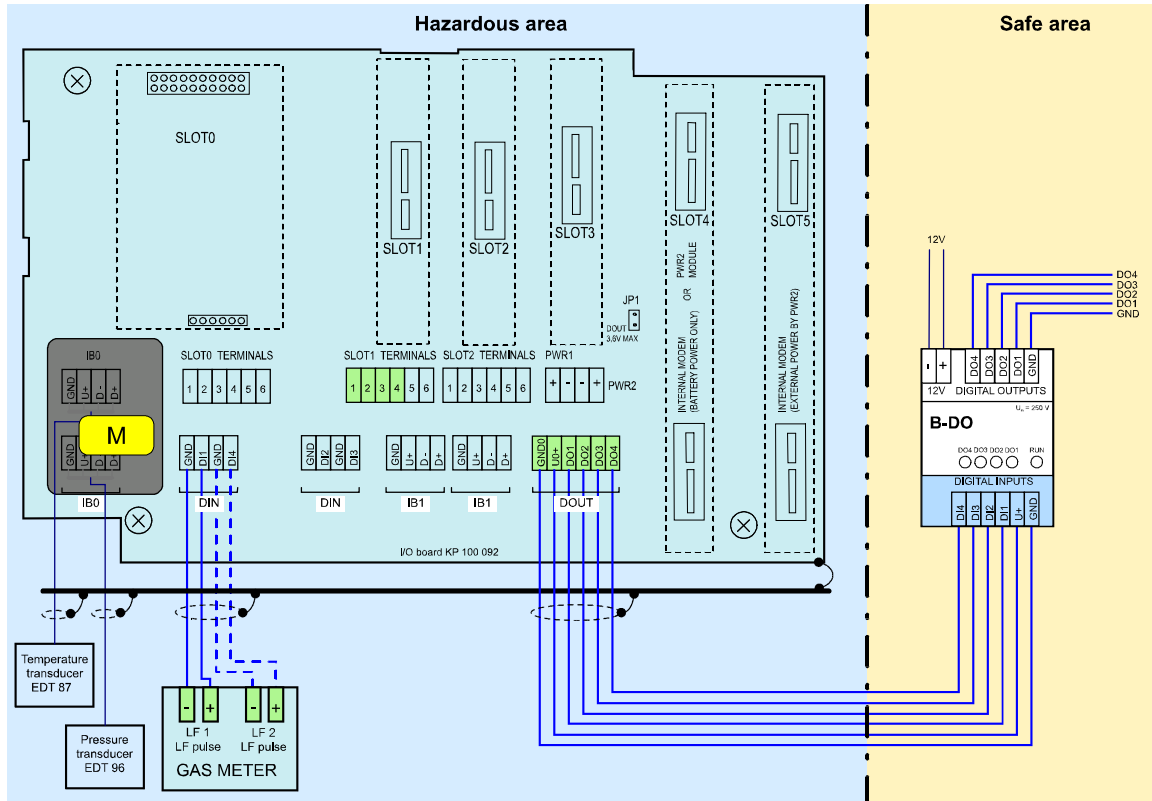

Fig. 18: Connecting digital outputs via B-DO separation barrier (Prilog 400)

### 5.5.5 Connecting Analog outputs

Primus 400 has two analog outputs per built-in S1-2AO module, each via terminals 2 (-) / 3 (+) and 5 (-) / 6 (+). A maximum of two modules can be installed (SLOT1 and SLOT 2).

RMG recommends the transmitter power supply unit KFD2-STC5-Ex1 (available as an accessory) for supply and as an Ex barrier.

46

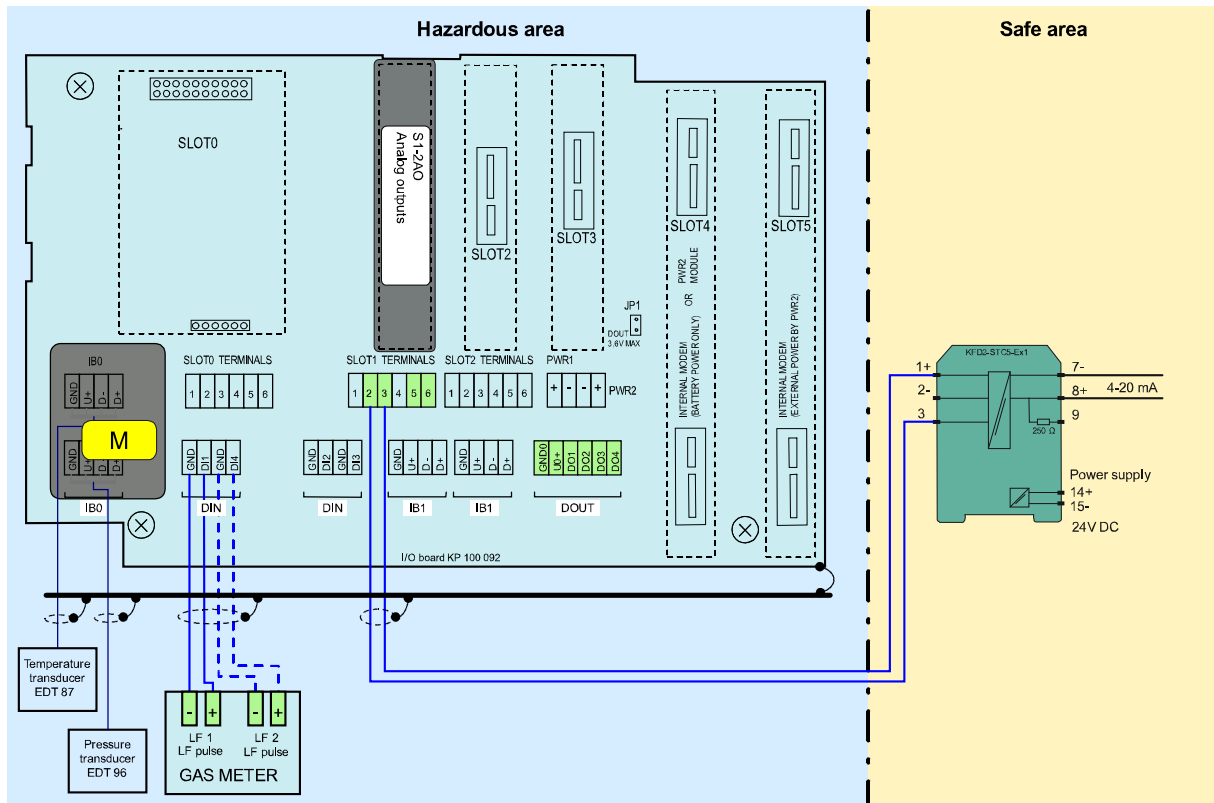

Fig. 19: Connecting analog outputs via KFD2-STC5-Ex1 barrier (Prilog 400)

### 5.5.6 Connection of pressure and temperature transducers

These transducers are connected to the I / O board in the IB0 terminal block, respectively terminal block IB1. Furthermore, they can be connected to the IB1 terminal block of the EXT1-T terminal board of the EXT1 module. In the case of the metrology channel, the connection is covered and secured with the metrological seal.

#### Caution

The intrinsically safe internal communication bus is connected to terminals IB0 and IB1. In case of any manipulation on terminals IB0 and IB1 it is necessary to disconnect the device power supply (ie external power supply and battery).

IB0, IB1	EDT 96 EDT 87	EDT 87 Temperature transducer	EDT 96 Pressure transducer	
			internal (var. A)	external (var. C)
terminal	signal	wire	wire	wire
GND	GND	green	green	green
U+	PWR	brown	brown	brown
D-	DATA-	yellow	yellow	yellow
D+	DATA+	white	white	white

Table 7: EDT 96 and EDT 87 transducers wire colors

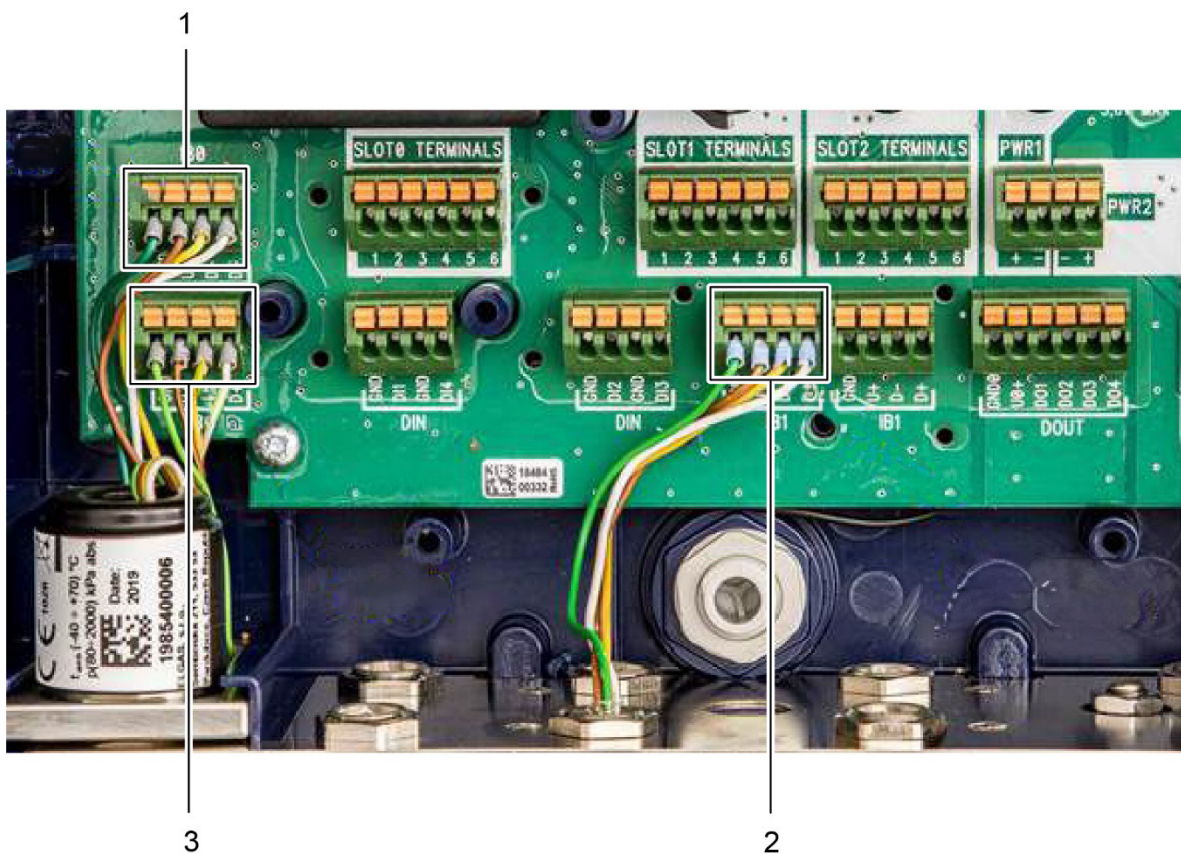

Fig. 20: EDT 96 and EDT 87 transducers connection

Item	Designation	Item	Designation
1	Connection EDT 87	3	Connection internal EDT 96
2	Connection EDT 87 or external EDT 96		

The EDT 96 pressure transmitter and the EDT 87 temperature transmitter are supplied by the manufacturer calibrated in whole measurement range. The calibration and correction data are stored in the transducer’s internal memory when the transmitter is calibrated and the resulting measured data already included with the corrections is passed to the instrument control unit.

Nevertheless, the device is equipped with the option of **one-point or two-point adjustment** (offset or offset + linearity) of the transducer using the supplied SW [19]. This option is protected by the metrology switch provided by a metrological seal. In the case of a data logger metrological verification, the adjustment is accessible to the user. A description of the device settings via user SW is given in [16].

For more information on EDT 87 and EDT 96 transducers, see [17] and [18].

### 5.5.7 Connecting External Power Supply

48

A cable with a minimum cross section of  $0.75 \text{ mm}^2$  is required for the external power supply from the PS-E (PS-E/A) intrinsically safe power supply.

To connect the external power supply to internal modem from the PS-M (PS-M/A) intrinsically safe power supply, cable with the conductor cross section of at least  $1 \text{ mm}^2$  is required. The table below shows the maximum length of this cable. The PG9 cable gland is designed for the cable. If both the corrector and the internal modem are powered from external power supply, only one 4-core cable can be used for the power supply.

Connection	Cable	Cable gland	Recommended type of cable	Max. length	Cable Ø
External power supply of the data logger (separate)	2-wire shielded	PG9 (PG7)	Unitronic LiYCY 2 x 0.75 Lappkabel	30 m	6.0 mm
External power supply of the modem (separate)	2-wire shielded	PG9	Unitronic LiYCY 2 x 1.5 Lappkabel, or	20 m	7.1 mm
			Unitronic LiYCY 2 x 1.0 Lappkabel	13 m	6.3 mm
External power supply of the data logger and the modem	4-wire shielded	PG9	Unitronic LiYCY 4 x 1,0 Lappkabel	13 m	7.3 mm

Table 8: Cables recommended for external power supply for the data logger and the modem

#### 5.5.7.1 External Power Supply for the Data Logger (Measurement Part)

External power supply can be used with Prilog 400 or Primus 400. If external power supply is used for the data logger (i.e. its measurement part), the S3-PWR1 module must be installed in SLOT 3. Power from an external intrinsically safe PS-E source is fed to the PWR1 terminals. In the event of a power failure, the data logger battery (B-03) performs the power backup function.

#### Warning

Also if the data logger is powered from an external power supply, it is necessary for the device to operate correctly that the batteries (B-03) of the data logger are inserted and connected in the device.



### 5.5.7.2 External Power Supply for the Internal Modem

The external power supply for the modem is ensured by the S4-PWR2 module in conjunction with the PS-M external intrinsically safe source. The S4-PWR2 module must be installed in SLOT 4. Power from an external intrinsically safe PS-M source is fed to the PWR2 terminals.

In the event of a power failure, the modem battery (HB-03, HB-04, etc.) performs the power backup function.

50

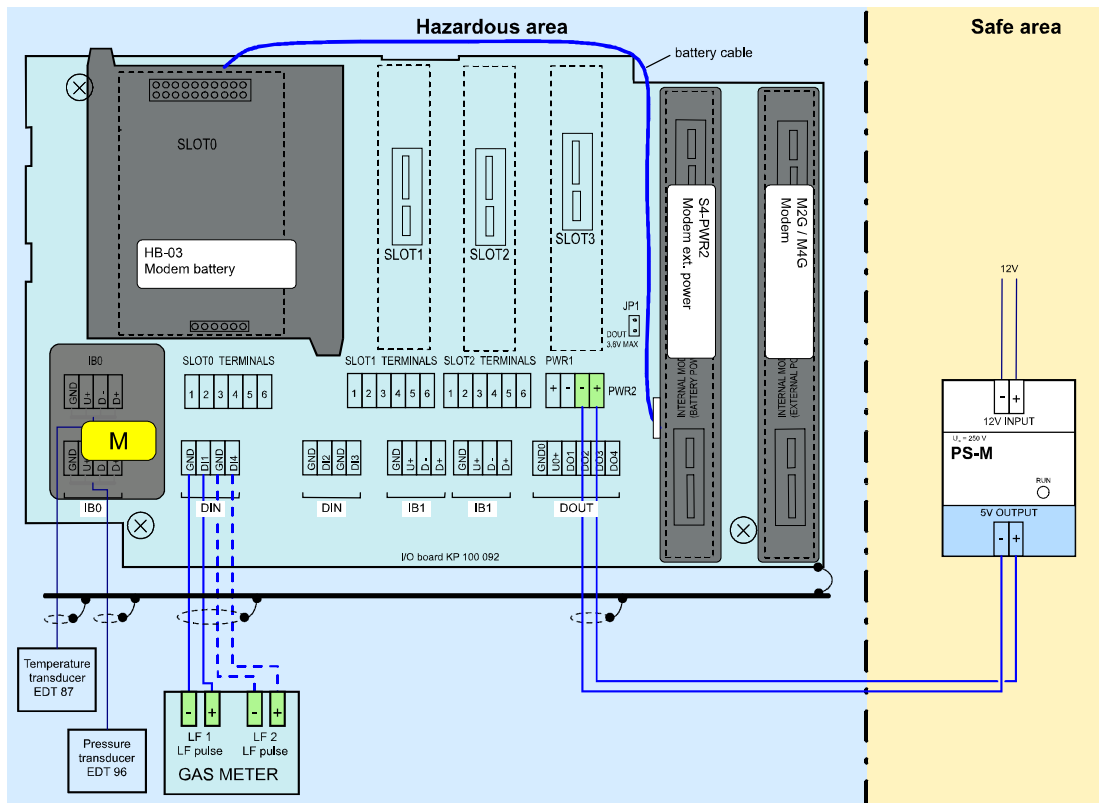

Fig. 22: PS-M External power supply for the internal modem with PS-M source

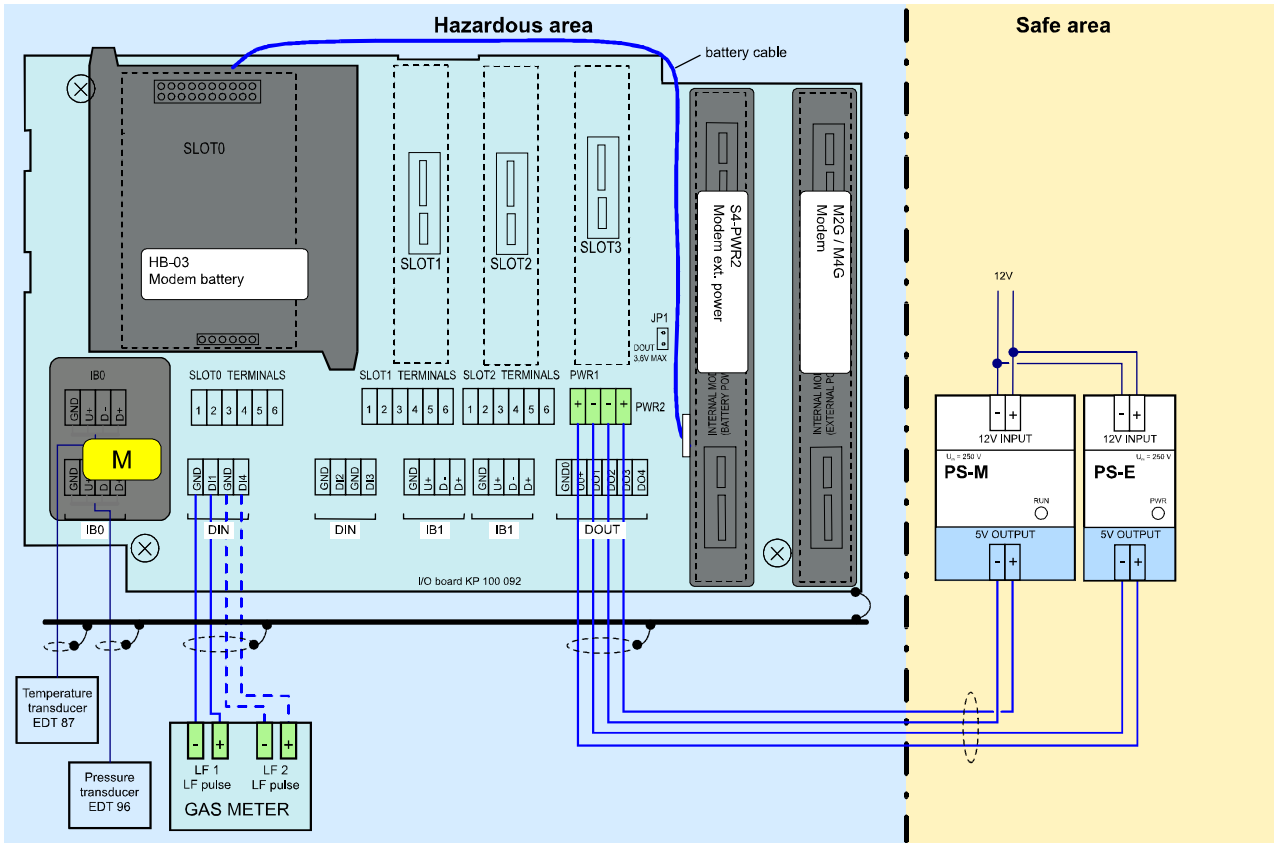

Fig. 23: External power supply to the data logger and the internal modem

### 5.5.8 Connection of RS232/RS485 Communication

**Prilog 400** - The device must be fitted with the S1-COM1 communication module. The module must be fitted in SLOT 1 or SLOT 2. The module offers RS232 or RS485 communication interface. Two S1-COM communication modules can be installed in the device. In this case, communication on two completely independent communication lines is possible. The cable is connected to SLOT 1 or SLOT2 terminal.

SLOT 1, SLOT 2	RS232	RS485
Terminal	Signal	Signal
1	---	D1+
2	---	D1-
3	GND	GND
4	CTS	U1+
5	RxD	---
6	TxD	---

Table 9: Assigning the terminals of the terminal block SLOT 1 and SLOT 2 when S1-COM module is installed

Communication interface	Cable	Cable gland	Recommended type of cable	Max. length	Cable Ø
RS232	4-wire shielded	PG7	Unitronic LiYCY 4 x 0,34 Lappkabel	30 m	5,7 mm
RS485	4-wire shielded	PG7	Unitronic LiYCY 4 x 0,34 Lappkabel	100 m *)	5,7 mm

\*) cable length may be reduced at higher communication speeds

Table 10: Recommended cables for RS232 and RS485 of the data logger

If there is no internal modem in the device, the communication can be extended by one additional independent RS232 communication interface using the S4-COM0 module in SLOT 4. Up to three independent communication lines are available.

#### Caution

The signals of the DOUT terminal block are intrinsically safe. Common devices must be connected via a suitable barrier (B-RS).

**Recommendation:**

If an external communication modem is connected to the device, an RS232 communication interface is required to connect the device with the B-RS barrier to ensure full duplex communication.

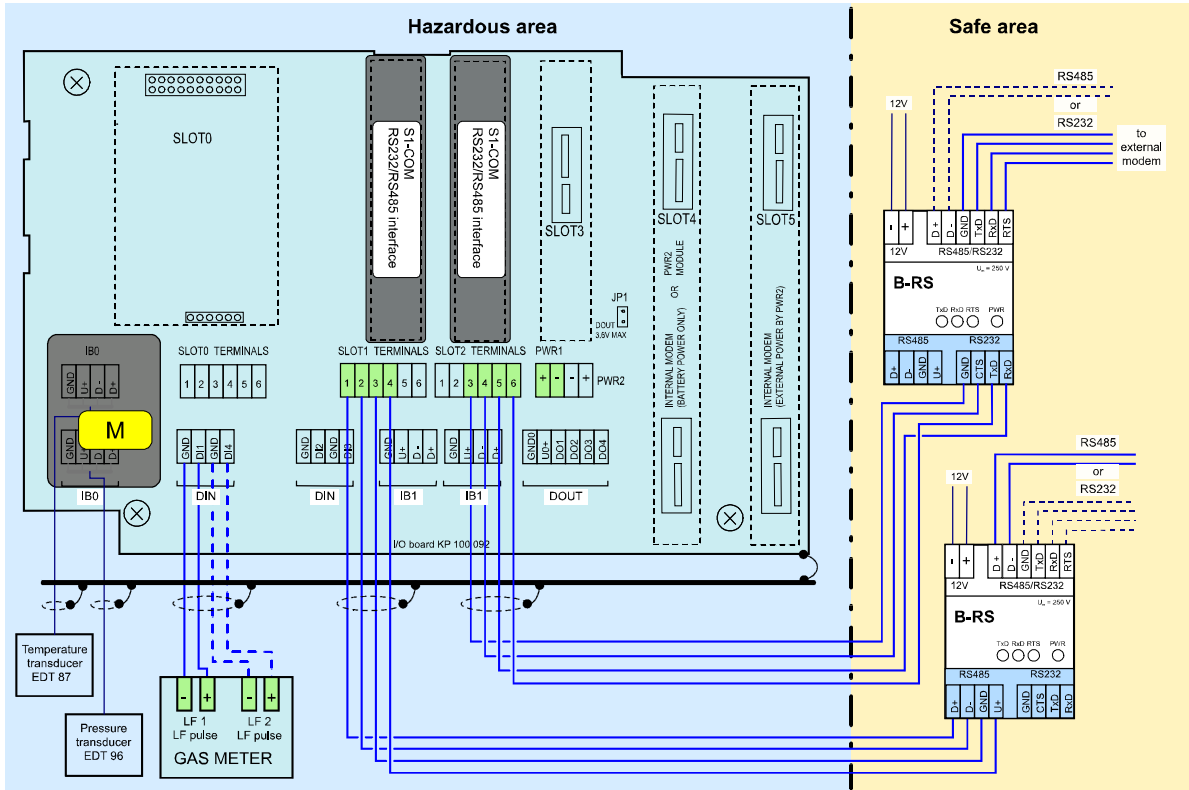

Fig. 24: Prilog 400, communication via two independent interfaces RS232/RS485

### 5.5.9 Connection to Network (Ethernet)

If a connection to a network is to be made, this can be done via an external converter from RS 485 to TCP/IP. RMG recommends the Phoenix Comserver (available as an accessory) for installation outside Zone 1.

54

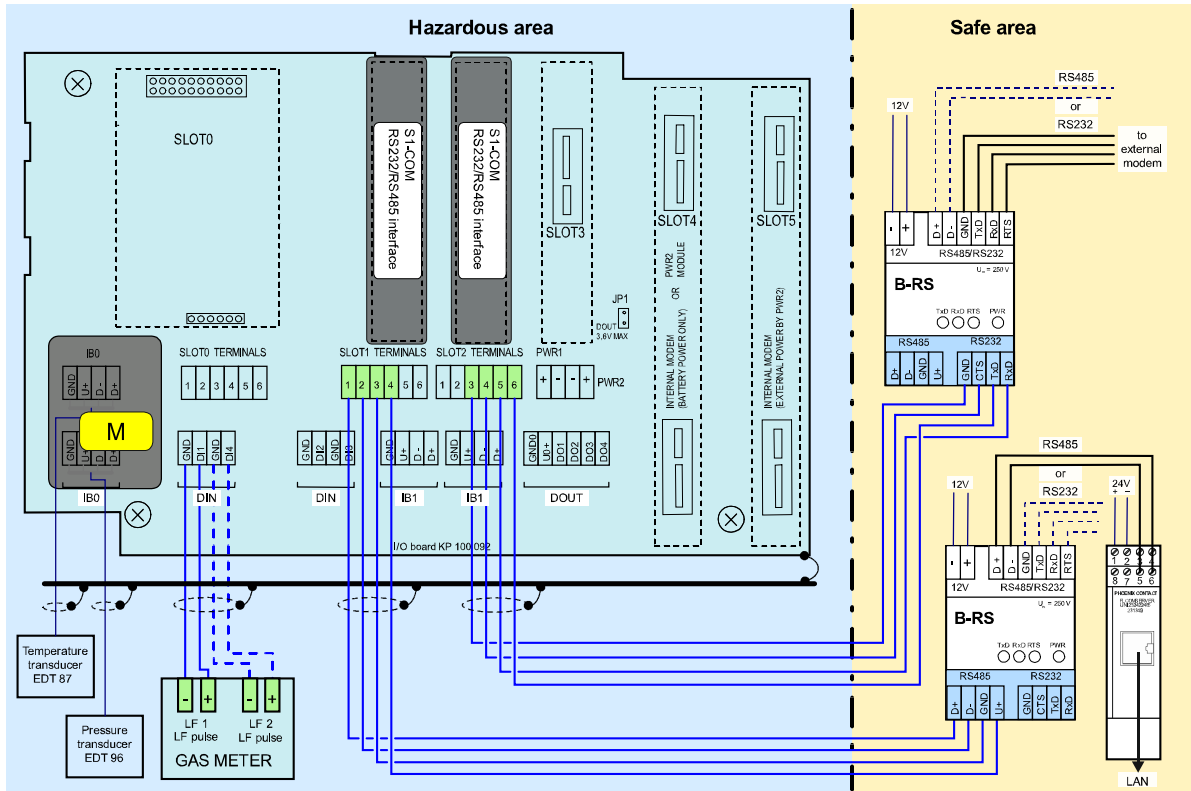

Fig. 25: Prilog 400, connection to RS232 as well as to LAN via RS485 and Comserver

Details on the configuration can be found in Appendix C.

## 5.6 Commissioning

The device is delivered either in the operating state with the battery connected or in the off mode with the battery disconnected. Both the battery of the device (B-03 etc.) and the modem battery (HB-03, HB-04, etc.) are equipped with a cable with a connector by which they are connected to the device.

**⚠ Warning**

**All the connectors in the device contain a mechanical safety lock (item 1) against accidental disconnection.**

**To disconnect the connector, first press the lock to release the connector, then pull the connector gently out of the socket. Never apply force grasping and pulling the cable, it can be damaged.**

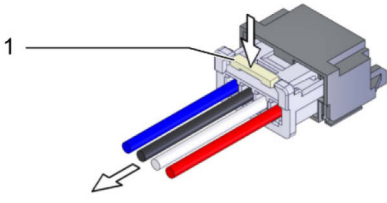

**To re-connect the cable to the device, plug the connector slightly so that the lock snaps into place, then check for the proper connection by a slight pull on the cable.**

The device comes with pre-set configuration parameters. After the mechanical assembly of the device, however, some parameters have to be set to ensure proper operation of the gas meter.

The basic operations to put the device in operation are as follows:

- **Connecting the batteries**
- **Checking (or adjusting) the system time of the device**
- **Setting the offtake point identification**
- **Setting the temperature and pressure substitute values**
- **Checking the diagnostics, removing device errors, if any, initiating cumulative status**
- **Resetting the device archive**

These basic operations can be performed either from the device keypad (Section 6.7) or from the PC with the operating program [19]. The connection to a PC, is preferably established using HIE 04 infrared head. If necessary, additional parameters can be set using the operating program (setting the pulse outputs, setpoints, etc.).

### 5.6.1 Connecting the Battery

The device display is off in the basic settings. The display light comes on when the Enter key is pressed for at least 2 seconds.

If the device is delivered in the off mode (nothing is displayed after pressing Enter for more than 2 seconds), the B-03 battery pack is disconnected from the unit. The battery cable (item 1) with connector (item 2) must be plugged into connector of the processor board (CPU module) to put the device into operation. This operation is also possible in potentially explosive environments.

When the battery is connected, the device is automatically in the operating mode.

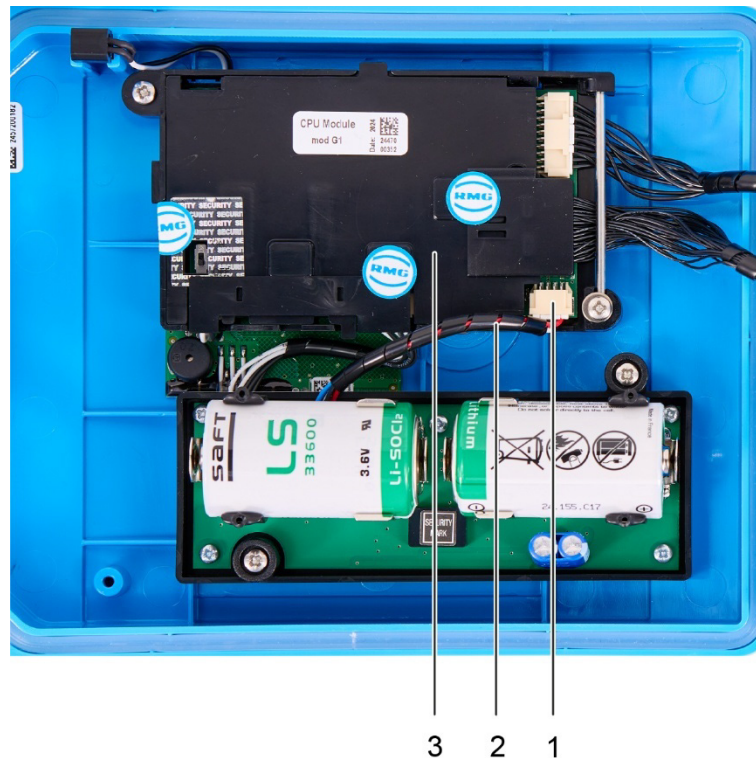

Fig. 26: Connecting the device battery

Item	Designation	Item	Designation
1	Connector	3	CPU module, processor board
2	Battery cable		

### 5.6.2 Connecting the Modem Battery

The version of the device with internal GSM/GPRS modem can be delivered with a disconnected modem battery.

When commissioning, the modem power supply battery pack (HB-03, HB-04, etc.) with the connector must be plugged into the connector of the module that is installed in the SLOT 4 position.

**⚠ Caution**

**The internal modem battery must always be connected to the module in SLOT 4:**

- If the external power supply of the modem is not used, the modem module is installed in SLOT 4. In this case, the modem battery is connected directly to the modem.
- If the external power supply of the modem is used, the modem is installed in SLOT 5, while the module of the external power supply of the modem S4-PWR2 is in SLOT 4. The battery is then connected to the S4-PWR2 connector.

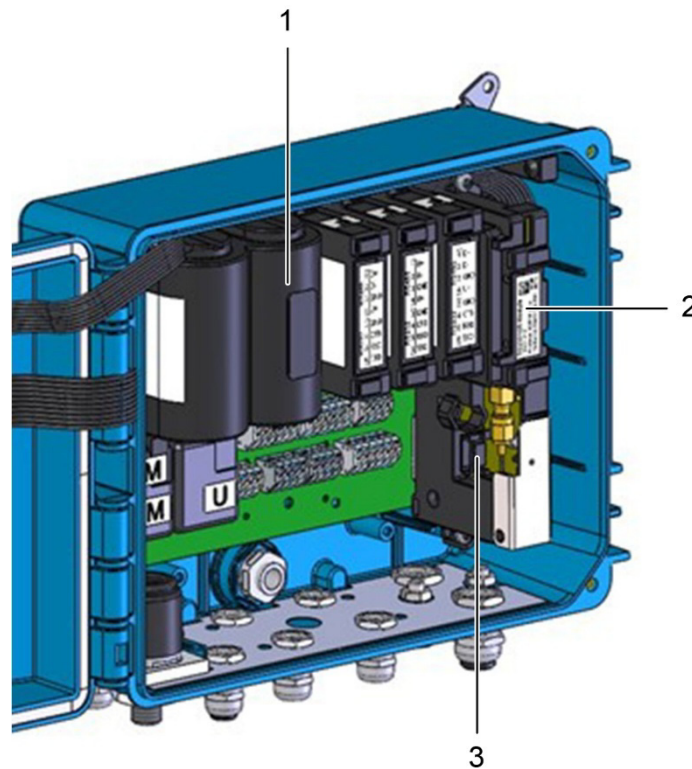

Fig. 27: Connecting the modem battery for Prilog 400

Item	Designation	Item	Designation
1	Modem battery	3	Connector of the modem battery
2	Modem module in SLOT 4 position		

**Note**

For longer time storing, it is recommended to remove the batteries from the device or at least disconnect them by pulling out the battery connector.

### 5.6.3 Installing SIM Card in the Modem

#### Install the SIM card into the modem

The device is delivered without the modem SIM card. Before using the modem, the SIM card received from the operator must be inserted into the modem. The SIM card holder is designed for miniSIM size of the SIM card.

58

#### To insert/remove the SIM card:

- If the external power supply of the modem is used, disconnect the power supply from the PWR2 terminals.
- Press safety lock (fig. 28, item 1) and pull gently the cable out to disconnect the connector of the battery modem.
- Push slightly in the direction of arrow (fig. 29, item 2) on the SIM card cover and tip it to the vertical position (fig. 29, item 3).

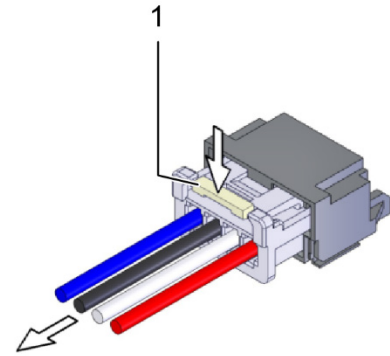

Fig. 28: Safety lock of connector

- Insert SIM card (fig. 30, item 5) into the holder and push it until you hear a click.

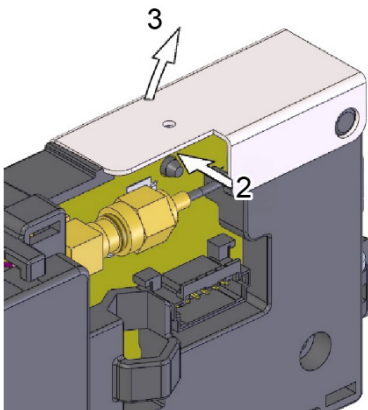

Fig. 29: Lift SIM card cover

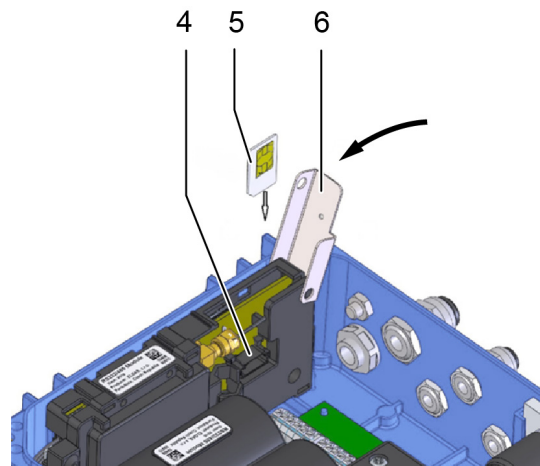

Fig. 30: Insert SIM card

- Option: To remove the SIM card, press the card until you hear a click, release the pressure, and the card moves several millimetres out. Grasp the card and remove it from the holder.
- After inserting the SIM card, close cover (fig. 30, item 6) and push it slightly in the direction of the arrow for easier insertion.
- Connect the connector of the battery of modem (fig. 30, item 4). For a device without external power supply of the modem, connect the connector to the modem. For a device with the external power supply of the modem, connect the connector to the S4-PWR2 module and then connect the wires to the PWR2 terminals of the external power supply of the modem.

## 6 Operating the Device

The device is not equipped with a power switch. The device turns automatically into the operation mode when the battery is inserted in the device. The device registers the LF pulses even with the main battery removed.



A 6-button keypad is used to operate the device and to display the measured and other values. The values are displayed on a 128 x 64 pixel graphic display.

For battery operation, the graphical display is switched off after 30 seconds since the last press

of any key. **The display lights up when the enter key  has been pressed for 2 seconds.** If the device is powered by an external power supply source, the display is permanently on.

The data to be displayed are selected in the device menu. The menu items are displayed depending on set parameters of the device. The contents of some menu items is user-configurable.

### Display Features

- Automatic display update for changing data with 1 sec period
- Autorepeat - when holding a key, the keystroke is automatically generated; this feature can be useful for example when viewing archives
- Display without special characters
- In compliance with the standard EN 12405-1+A2, Section 6.3.1.5, the display switches to the basic settings after a certain idle time. The time after which the display switches to basic can be set in the parameters.
- In order to simplify the operation by a untrained user, the option to display actual values one after another by pressing the  key is included. Before this, it is necessary to exit by pressing the  key several times to the top menu level.
- For energy saving purposes, the device's graphic display goes out after 30 seconds when in battery operation mode, and lights up only when any key is pressed.

## 6.1 Keypad

- Pressing the Enter key for 2 seconds **turns the display on**
- Moving from one menu item into lower level menu (submenu)
- When displaying actual values, Enter will scroll through the screen to display all the quantities one after another

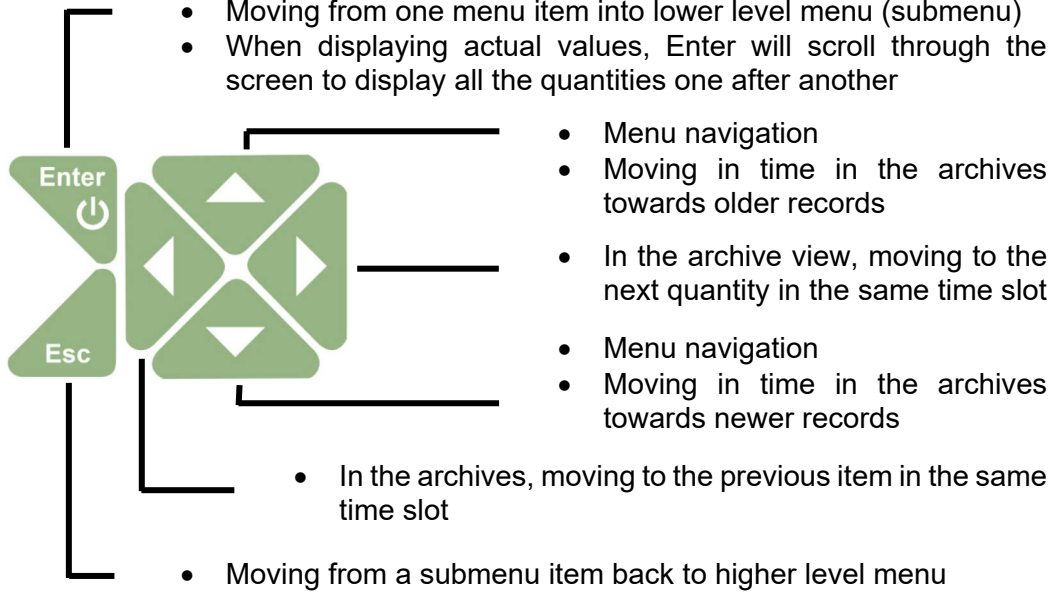

Fig. 31: Function of the keys

## 6.2 System Menu

The device is operated based on selecting items from the menu. For the purposes of further interpretation, we call the basic menu items the highest items. By entering those items, navigate to the lower menu levels (submenus).

If the display has been off for a longer time, the home screen with a volume Vm value is displayed.

### Home Screen (Initial Display)

The first line in the top right corner displays icons indicating the basic status of the device.

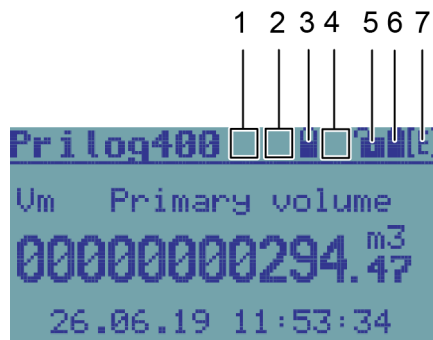

Fig. 32: Icon positions

Item	Designation	Symbol	Description
1	Operating mode		Not configured
			Maintenance
			Normal
2	Communication status		Communication via internal modem or via optical head
			Communication via the modem or the head disabled
3	Power state of the internal modem		External power supply of the modem connected
			Battery charge status 100 %
			Battery charge status 75 – 91 %
			Battery charge status 58 – 75 %
			Battery charge status 42 – 58 %
			Battery charge status 25 – 42 %
			Battery charge status 8 – 25 %
			Battery charge status 0 – 8 %











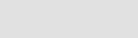



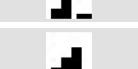



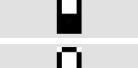
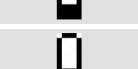
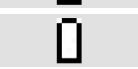

Item	Designation	Symbol	Description
4	Status of the modem, signal strength		The modem is off or not set in the parameters
			The modem is registering (connecting) in (to) the network
			Modem connected, signal strength 0 – 25 %
			Modem connected, signal strength 25 – 50 %
			Modem connected, signal strength 50 – 75 %
			Modem connected, signal strength 75 – 90 %
			Modem connected, signal strength 90 – 100 %
5	Status of the service and metrological switch		Writing to the device disabled (both the service and metrological switches are in the OFF position)
			Writing to the service area enabled (service switch is ON)
			Blinking - Writing to the metrological area enabled (metrological switch is ON)
6	Power state of the device		The external power supply of the device is connected
			Battery charge status 100 %
			Battery charge status 75 – 91%
			Battery charge status 58 – 75 %
			Battery charge status 42 – 58 %
			Battery charge status 25 – 42 %
			Battery charge status 8 – 25 %
			Battery charge status 0 – 8 %
7	Device status (sum status)		The compressibility is being calculated or the firmware is verified after the remote download update
			The device works flawlessly
			An error has occurred in the device
			The device has generated a warning message

Table 11: Status icons of the display

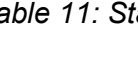
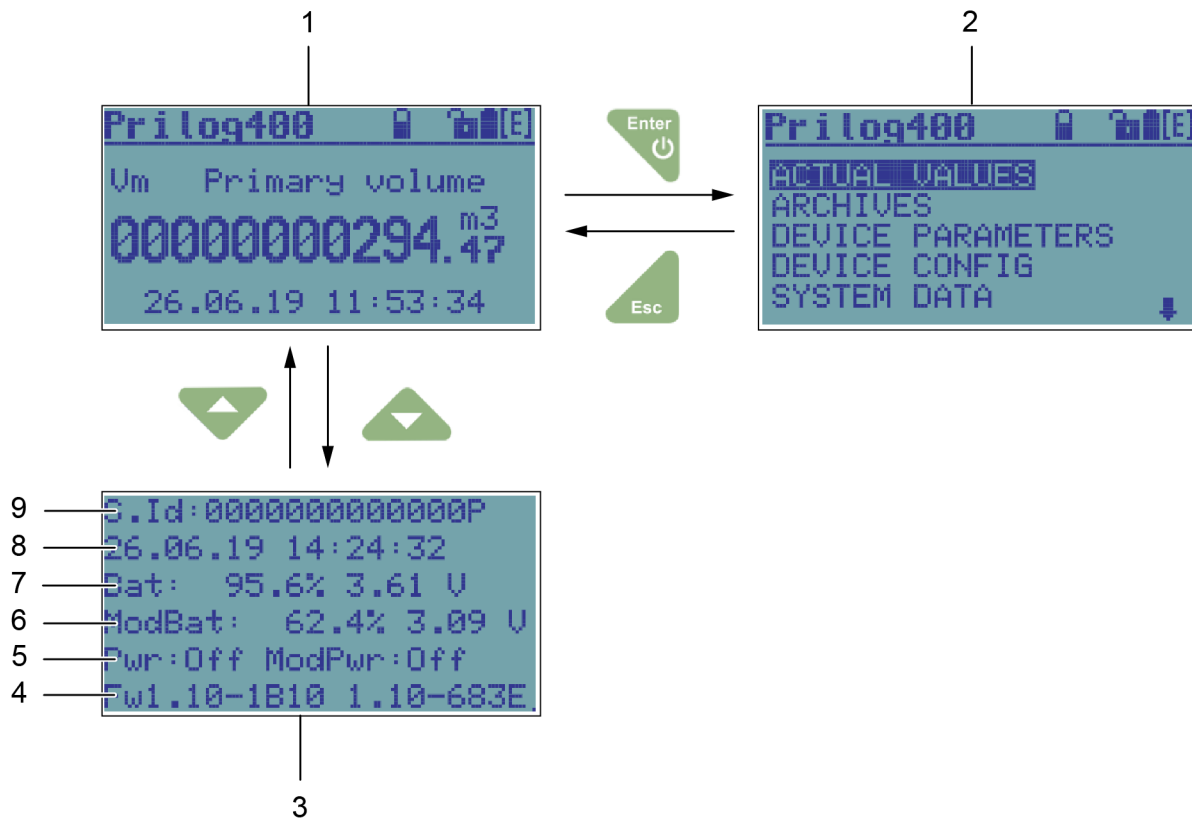
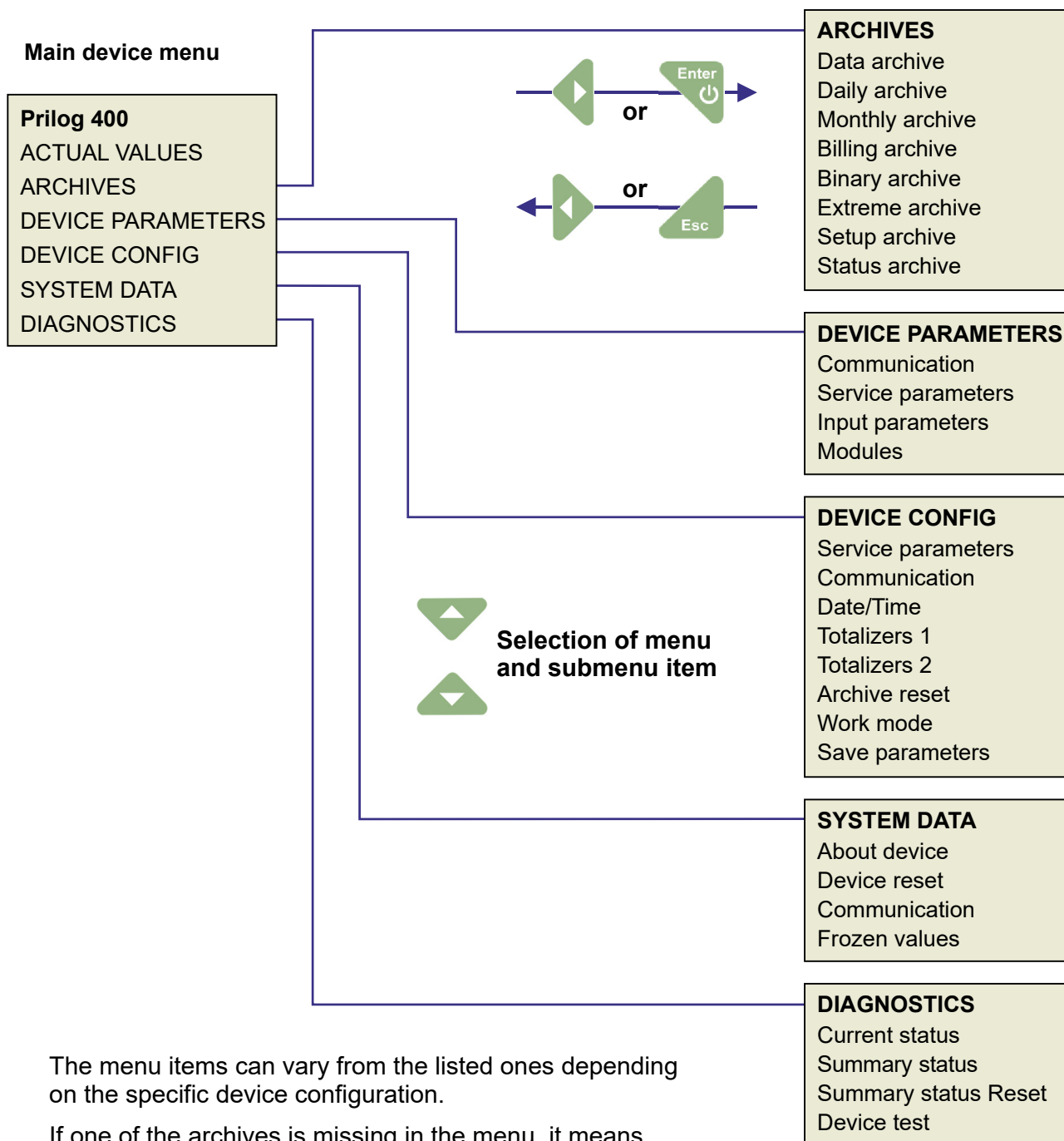

Fig. 33: Basic navigation from the home screen

Item	Designation	Item	Designation
1	Home screen	6	Status of the modem battery (level of charging, voltage)
2	Main menu	7	Status of the device battery (level of charging, voltage)
3	System data (for devices)	8	System time
4	The versions of the metrological firmware and its checksum (CRC) and version of the application firmware and its checksum (CRC)	9	Station identification
5	Status of the external power supply of the device and modem (on/off)		

### 6.3 Main Menu

The selected menu item is highlighted inversely on the display.





The menu items can vary from the listed ones depending on the specific device configuration.

If one of the archives is missing in the menu, it means that none of the quantities in the device has archiving set up in such archive.

Fig. 34: Main menu of the device and the first-level submenu

## 6.4 Actual Values Menu

By pressing the key **Enter** the actual values are displayed. To scroll through the displayed data, use the arrow up  and down keys .

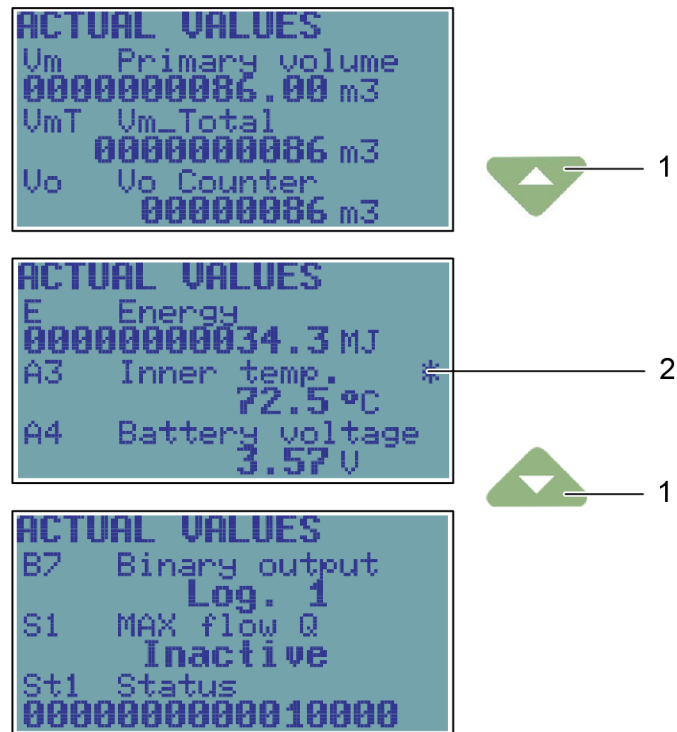

Fig. 35: Example of actual values display

Item	Designation	Function
1	navigation arrow	<ul style="list-style-type: none"> <li>scrolling through the displayed values.</li> </ul>
2	asterisk symbol	<ul style="list-style-type: none"> <li>indicates that the measurement range for the analogue value has been exceeded.</li> </ul>

## 6.5 Archives Menu

For data, daily, monthly, and binary archives, the way the data is displayed is identical and can be seen in the figure below.

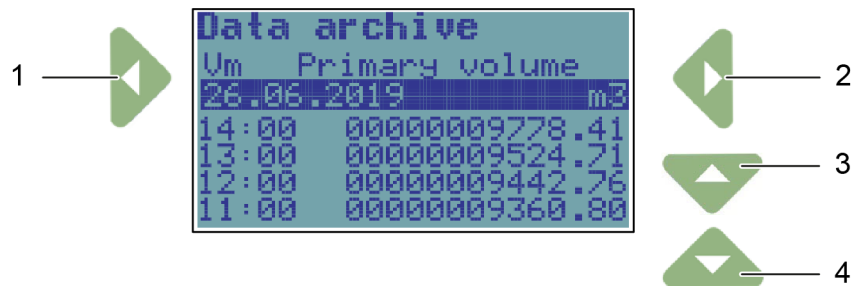

Fig. 36: Navigation in the archives (in this case, with archiving frequency 1 h)

Item	Designation	Function
1	Left navigation arrow	<ul style="list-style-type: none"> <li>moving to the previous measurand</li> </ul>
2	Right navigation arrow	<ul style="list-style-type: none"> <li>moving to the next measurand.</li> </ul>
3	Up navigation arrow	<ul style="list-style-type: none"> <li>moving forward in time</li> </ul>
4	Down navigation arrow	<ul style="list-style-type: none"> <li>moving backward in time (to the history)</li> </ul>

The binary archive is displayed in the same way, only the records are not stored in the archive with the archiving frequency, but at times when the status of some of the stored quantities has changed.

To end archive viewing, press the key **Esc**.

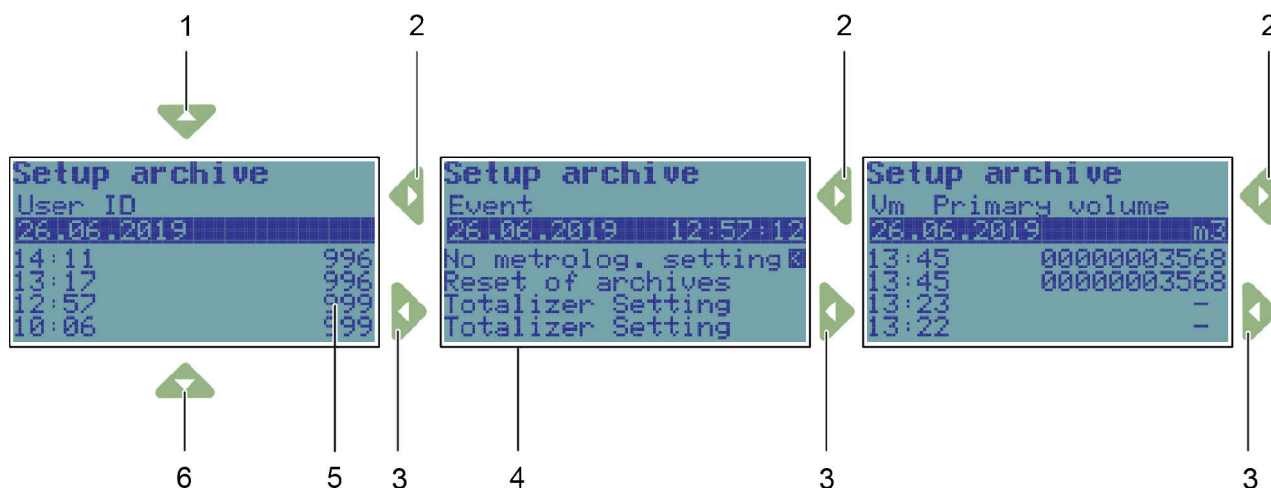

Fig. 37: Display of the settings archive

Item	Designation	Function
1	Up navigation arrow	<ul style="list-style-type: none"> <li>moving forward in time</li> </ul>
2	Right navigation arrow	<ul style="list-style-type: none"> <li>moving to the next information at the selected time</li> </ul>
3	Left navigation arrow	<ul style="list-style-type: none"> <li>moving to the previous information at the selected time</li> </ul>
4	Setup archive Event	<ul style="list-style-type: none"> <li>settings made at the selected time (26.06.2019, 12:57:12)</li> </ul>
5	User ID	<ul style="list-style-type: none"> <li>ID of the user who made the setting</li> </ul>
6	Down navigation arrow	<ul style="list-style-type: none"> <li>moving backward in time (to the history)</li> </ul>

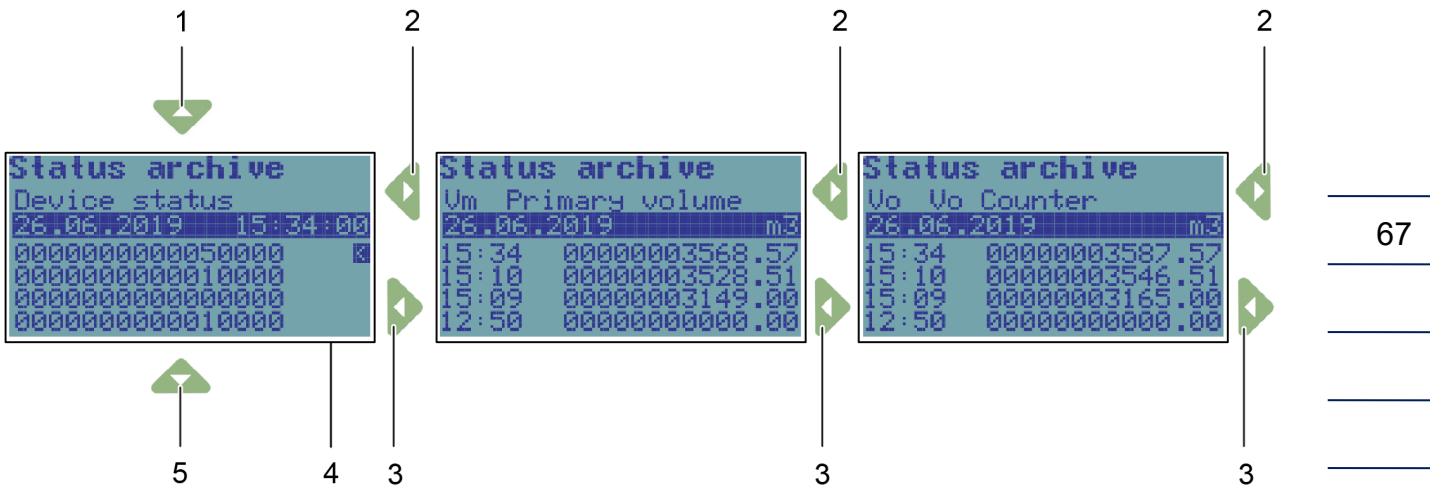

Fig. 38: Display of the status archive

Item	Designation	Function
1	Up navigation arrow	▪ moving forward in time
2	Right navigation arrow	▪ moving to the next information at the selected time
3	Left navigation arrow	▪ moving to the previous information at the selected time
4	Device Status	▪ shows the device status
5	Down navigation arrow	▪ moving backward in time (to the history)

## 6.6 Device Parameters Menu

The following parameters are displayed in the **Communication** menu:

- General parameters (network address1, network address2)
- IR head (baud rate, communication protocol)
- Internal modem (baud rate, communication protocol, communication device)
- Serial COM1 (baud rate, communication protocol, communication device)
- Serial COM2 (baud rate, communication protocol, communication device)

The following are displayed in the **Service Parameters** menu:

- Serial number of the device
- Application FW, version and checksum (CRC)
- Metrological FW, version and Checksum (CRC)
- FW Loader, version and checksum (CRC)
- Memory size [byte]
- Station Identification

Scroll through the display using the  and  keys. The end of the data is marked with "<" on the display.

In the **Input Parameters** menu, the following data are displayed:

- Vm (gas meter)**
  - Marking of input terminals
  - Gas meter constant kp [imp/m3]
  - Serial number of the meter
  
- t EDT 87 (temperature measurement)**
  - Transducer communication address
  - Measuring range
  - Serial number of the temperature sensor
  
- p EDT 96 (pressure measurement)**
  - Transducer communication address
  - Pressure range
  - Serial number of the pressure transducer

plus e.g. parameters of the 2nd channel and additional transducers (non-metrological)

In the **Modules** menu, you can view the basic data of the modules, transducers, batteries, and other system components. Use the und keys to scroll through the data.

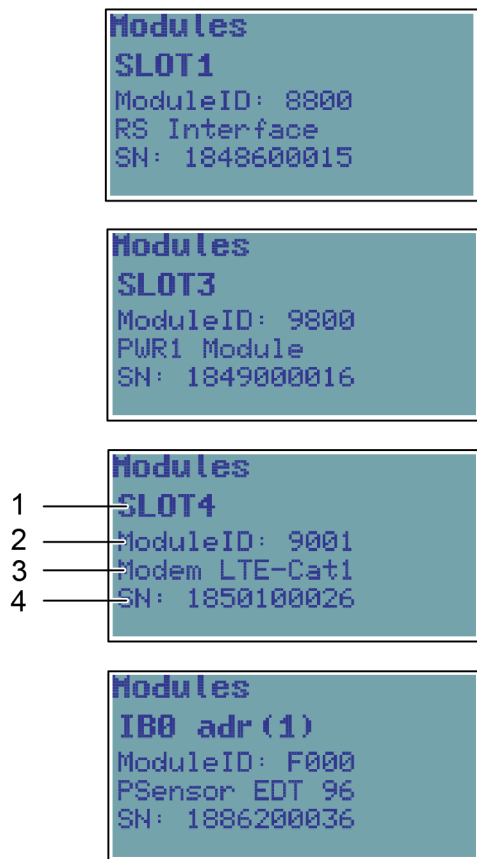



Fig. 39: Example of the displayed information on device components

Item	Designation	Item	Designation
1	Number of the slot in which the module is installed or the identification of the internal communication bus to which the module (transducer) is connected.	3	Module designation
2	Module identification number	4	Serial number of the module



## 6.7 Device Configuration Menu

In this menu, the device parameters can be set directly from the device keypad.



 <b>Caution</b>
<p>Setting device parameters from the keypad can be protected:</p> <ul style="list-style-type: none"> <li>• By the service switch (the switch must be set to ON for parameter changes)</li> <li>• By a password (for more details, refer to Section 11.6.2)</li> </ul> <p>If the service switch is set to OFF, the message "Parameters cannot be set" appears in the display.</p>

The following parameters can be set:

<b>Service parameters</b>	<ul style="list-style-type: none"> <li>- Station Identification</li> <li>- Gas hour</li> </ul>
<b>Communication</b>	<ul style="list-style-type: none"> <li>- General parameters</li> <li>- IR head</li> <li>- Communication protocol</li> <li>- Internal modem</li> <li>- Serial COM1</li> <li>- Serial COM2</li> <li>(the baud rate and communication protocol are set separately for each communication)</li> </ul>
<b>Date/Time</b>	HH:MM/DD:MM:YYYY
<b>Volume parameters (Totalizers 1,2)</b>	<ul style="list-style-type: none"> <li>- kp1, kp2 Gas meter constant [imp/m3]</li> <li>- Vm1, Vm2 Primary volume</li> <li>- Vs1, Vs2 Disturbed quantity primary volume</li> <li>- Serial numbers of the gas meters</li> <li>- Qmax1, Qmax2 Max. gas flow rate</li> </ul>
<b>Archive reset</b>	<ul style="list-style-type: none"> <li>Data archive</li> <li>Daily archive</li> <li>Monthly archive</li> <li>Binary archive</li> <li>Limit archive</li> <li>(Settings Archive)</li> <li>(Status Archive)</li> </ul>
<b>Work mode</b>	normal (standard)
<b>Saving parameters</b>	Entering the changed parameters in the device

To edit a parameter, press the  or  keys to move the parameter to the first row on the display (the parameter is displayed inversely). Start the editing by pressing the Enter key.

The edited position in the row is indicated with the symbol . The keys for parameter editing have the following functions:

	Selecting the edited position in the row
	Selecting and entering an alphanumeric character (space, 0 to 9, A to Z, a to z)
	End of editing the parameter

## Saving the Parameters



After you finish editing the parameters, the changes must be saved in the device. To do this, choose "Save Parameters". Successful saving the parameters in the device is confirmed by the message "Valid Data".

Totalizer values and Current time are saved immediately after entering the value. A confirmation dialog is displayed before the value is saved, and on confirmation, the value is stored in the appropriate register.

## 6.8 System data Menu

- About Device
- Device Reset
- Communication
- Frozen Values

### 6.8.1 About Device

The basic system parameters are displayed here, see fig. 34. In addition, you can use the  and  keys to display additional data (digital inputs and outputs, etc.).

### 6.8.2 Device Reset

The command is non-destructive. After selecting the device reset, the program jumps to the start address and re-initializes the entire metering system. Neither the contents of all archives, nor the values of all V and V<sub>o</sub> gas volumes change during this operation. The same applies to all the other set parameters. The command execution is independent of the position of the service switch.

### 6.8.3 Communication

**Note**

This option makes it possible to:

- **View important information about the modems** connected to the device (the modem must be set in the device parameters),
- **Verify that the modem settings are correct by simple testing the connection** to the master communication point (modem) of the dispatch centre (regardless of the timer setting and calls of the internal timers of the device).

For modem communication, also some diagnostic data is displayed.

In the first step, the modem is selected (the device allows for connecting no more than 2 modems, one internal and one external). The following options can be selected for each of selected modems.

#### 6.8.3.1 Modem Status

The current status of the modem is displayed on the 2nd row of the display. The following rows contain additional information.

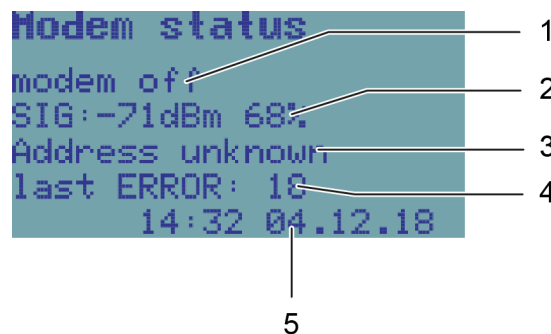

Fig. 40: Modem status display

1 Modem status	
modem not present	the modem is not enabled in the device parameters
modem off	the modem power is off
modem connecting	the modem was connected to power (by software-the internal control signal connected the modem power supply)
modem init	the device is sending initialization commands to the modem
modem on	the modem is on and initialized
modem connected; 2G connected	the modem is logged on the network
modem disconnecting	the modem is logging off from the network and turning off <sup>10)</sup>

<sup>10)</sup> If modem communication is in progress, the modem is turned off only after the communication has been completed.

### 2 Signal strength<sup>11)</sup>

Information about signal strength at the location of the device. The Modem Status command does not measure the signal strength. If this information appears on the display, it is the data ascertained at the time when the modem last logged on to the network. The strength is stated in dBm and in %. Comparison table - see table 12

### 3 IP Address

For GPRS communication, the IP address of the device is displayed.

### 4 Modem Error<sup>11)</sup>

The code of the last modem error is displayed if an error occurred. The meaning of the error according to its numeric code is specified in table 13.

### 5 Error Date and Time<sup>11)</sup>

For modem error, the date and time of the last error is displayed.

#### 6.8.3.2 Signal Testing

After selecting this option (the modem must be set in the device parameters, it can be turned off), the device turns on the modem power supply, initializes the modem and measures the signal strength after connecting to the mobile network. (The sequence (fig. 41, item 2) modem off, modem on, modem init, modem connected is run). The time limit for measuring the signal (fig. 41, item 1) is 120 seconds.

The minimum recommended RSSI value for GPRS communication is -85 dBm (i.e. 45%). Under this value, the device displays error number 10 (see table 13). In addition, low GSM/GPRS signal levels significantly reduce the reported battery life of the modem.



Fig. 41: Display of the signal testing status

Item	Designation	Function
1	Display sequence duration	<ul style="list-style-type: none"> <li>shows the remaining duration of the measurement (counting down)</li> </ul>
2	Display sequence status	<ul style="list-style-type: none"> <li>shows the status of the sequence currently being executed:                             <ul style="list-style-type: none"> <li>– Modem off</li> <li>– Modem on</li> <li>– Modem-Init.</li> </ul> </li> <li>Modem is connecting</li> </ul>
3	Display signal measurement	<ul style="list-style-type: none"> <li>shows the measured signal strength.</li> </ul>
4	Mobile connection status	<ul style="list-style-type: none"> <li>shows the status of the mobile connection.</li> </ul>

<sup>11)</sup> After resetting the device (see Section 6.8.2), or after changing some important modem parameters, this value is reset.

RSSI [dBm]	-51	-61	-71	-81	-91	-101	-113
RSSI [%]	100.00	83.87	67.74	51.61	35.48	19.35	0.00
RSSI [rel]	31	26	21	16	11	6	0

Table 12: RSSI signal strength conversion table between dBm, %, and relative units

Code	Error description
<b>General Errors</b>	
0	modem without error indication
1	modem does not respond
20	modem returns "ERROR"
<b>SIM card errors</b>	
2	PIN code requested, but not stored in the configuration data
3	PIN code requested, incorrect PIN code stored in the configuration data
4	PIN blocked, PUK code requested
5	SIM card is not inserted
<b>GSM network registration errors</b>	
6	registration in the GSM network takes longer than usual (> ~ 20s after the modem is turned on)
7	not registered in the GSM network, not searching for the network currently
8	registration in the GSM network disabled (eg no active roaming and no home operator available)
9	registration in the GSM network impossible for unknown reasons
10	low GSM signal level $\leq -85$ dBm (the error is saved only if the modem is registered in the GSM network)
<b>Initialization errors</b>	
11	incorrect initialization command entered in the configuration data (Initialization or Special Initialization field in the operating/service software [19], [20])
<b>Dial-up errors</b>	
12	GPRS or GSM/CSD cannot be dialled, or the connection that has already been established fails due to error reasons (the modem returns "NO CARRIER", "BUSY" or "NO DIALTONE")
<b>PPP protocol errors - errors in connecting to GPRS</b>	
13	LCP protocol error
14	PAP protocol error (the user name and password may be incorrectly set, but in practice and in the wrong setting this phase is performed and ends up in the IPCP phase)
15	CHAP protocol error (the username and password may be incorrectly set, but in practice and in the wrong setting this phase is performed and ends up in the IPCP phase)
16	IP address allocation error (may also be caused by a wrong username and password)

TCP protocol errors	
17	TCP session error - RST packet sent
18	error opening TCP session in Client mode - failed connection to remote server
SMS errors	
19	SMS could not be sent

Table 13: Error Codes of the Modem

### 6.8.3.3 Power on Modem

This option will turn the modem on for 5 minutes (i.e. 300 seconds; the remaining time in seconds to turning off the modem (Fig. 42, Pos. 1) shows in the top right corner of the display). This command is useful, for example, to test the communication when setting up the device (basically simulates the function of the internal parameter "Timer - Service Window" described in the TELVES program parameterization).

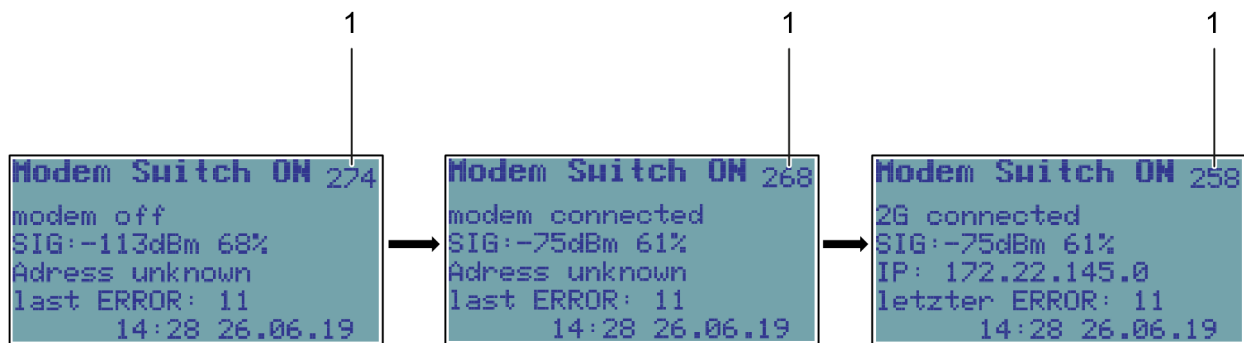

Fig. 42: Display: Option modem switch ON

Item	Designation	Function
1	Display sequence duration	<ul style="list-style-type: none"> <li>shows the time remaining until the modem switches off (counting down)</li> </ul>

### 6.8.3.4 Call to Dispatch

If the device is configured to call the dispatch centre, this command can verify that the device call to the master system is correct (applies to both dial-up connection and GPRS mode). This option basically simulates the function of the internal parameter "Timer - Call Window". On the first row of the display, the modem states (switching on, initializing, connections ...) are displayed sequentially through which the modem goes through when the connection is established. When the connection is established, the device sends the calling data frame to the dispatch centre, which must accept it when the settings are correct. After that, the modem terminates the connection and is turned off.

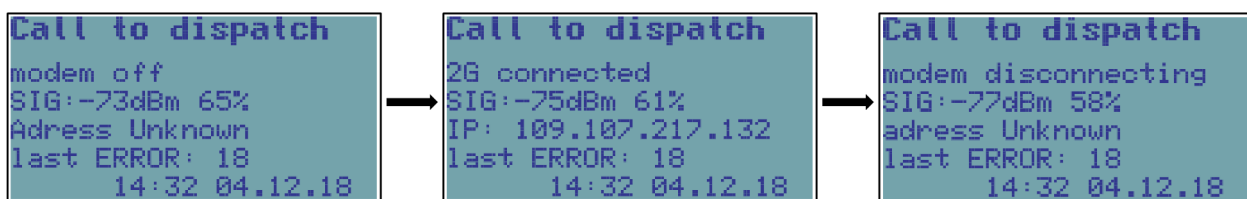
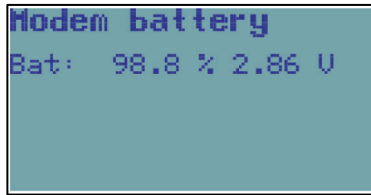

Fig. 43: Display: Connection to the dispatch centre

**6.8.3.5 Modem Battery**

It displays the battery charge status of the modem in % and the current battery voltage. If the battery is disconnected, the message "Communication Error"/"Comm.error" appears.



*Fig. 44: Display: Modem battery charge level*

**6.8.4 Frozen Values**

This option freezes the actual values. Use this option if the measured data have to be copied manually.

## 6.9 Diagnostics

In the "Diagnostics" menu, the status of the data logger is displayed. The errors are indicated by the prefix "E" and the identification number; similarly, the prefix "W" is used for warnings. For a complete list of error and warning messages see paragraph 6.9.5.

76

### Note

#### Technical assistance in troubleshooting

If there are any problems with the operation of the device for any reason, technical support personnel may be contacted. Contacts are available at [service@rmg.com](mailto:service@rmg.com).

To help you find a solution to the problem, we recommend providing as much as possible information about your device and connections to related devices nearby. Diagnostic and solving the problem would be easier, if you send us a \*.dt\_all diagnostic file obtained from the device via the operating SW [19].

### 6.9.1 Current Status

This menu displays the current status of the device. Press the "right arrow" key to display all current errors and warnings of the data logger one after another.

### 6.9.2 Summary Status

The summary status is used to monitor the occurrence of active error states (individual device status bits) **since the last summary status reset**. This means also the statuses of the device that have been removed by the operator, or have disappeared over time (typically, for example, exceeding the pressure limit, etc.) are recorded in memory.

```
Summary status
E7 sensor commun
W5 ext power fail
W11 T1 Min.Lim.
W34 mtrl.switch
```

Fig. 45: Example of a summary status display

Basic status information is also displayed in the form of an icon (see Section 6.2) of the home screen.

### 6.9.3 Summary Status Reset

After this option has been selected using the device keypad or via the "Summary Status Reset" option from the "Setup-Diagnostics" menu of the PC operating SW, the summary status is initialized, i.e. the current status is set according to the actual status. To enable initialization, the service switch must be ON. If switched to OFF, a message is displayed that the initialization cannot be performed.

## 6.9.4 Device Test

After selecting this menu item, the device tests its internal state and displays a list of detected errors and warnings. The test of the device runs for several seconds and does not affect the measuring and archiving operation of the device. The execution of the command is independent of the position of the service switch.

The notification is displayed during the test.

## 6.9.5 Device Errors Display

Error messages are displayed in the "Actual Status", "Summary Status" and "Device Test" menus. Autodiagnosics runs regularly, a full test of the device once a day, a sensor swap test every hour or irregularly when the device is switched on. The test can be also triggered by selecting the "Device Test" function from the keypad.

*The shortened form of summary diagnostics is displayed in the right corner of the top level menu in the form of OK, Err or Wrn (see Section 6.2). This shortened form is the sum of the individual states, and in each case, the abbreviation with the highest priority is displayed. The priority order is Err, Wrn, OK, starting with the highest one. More detailed diagnostic information can be displayed using the operating SW [19]. An overview of the indicated Err messages is included in table 14, and the Wrn report is provided in table 15.*

Displayed Message	bit	Description
E0 program CRC	0	Firmware checksum error.
E1 loader CRC	1	Loader checksum error.
E2 parameter CRC	2	Device parameter checksum error.
E3 memory error	3	Device memory error.
E4		- not used -
E5 setting archive full	5	The number of changes made to the device configuration has filled the archive capacity. The device is still working, only the parameter changing is blocked. It can be unblocked in ASC only.
E6 transd. replacement	6	Unauthorized replacement of the sensor or modification of its parameters has been made.
E7 trans. communication	7	Error in communication with the sensor.
E8 transd. error	8	Transducer error.
E9 battery discharged	9	The EVC battery is discharged (the remaining battery capacity is about 10%).
E10	10	- not used -
E11	17	- not used -
E12		- not used -
E13 battery disconnected	19	Battery is disconnected
E14 P1 under limit	32	Pressure range exceeded (1st channel)
E15 P1 above limit	33	
E16 P1 error	36	Pressure transducer error

E17 T1 under limit	37	Temperature range exceeded (1st channel)
E18 T1 T1 above limit	38	
E19 T1 error	41	Temperature transducer error
E20 P2 under limit	48	Pressure range exceeded (2nd channel)
E21 P2 above limit	49	
E22 P2 error	52	Pressure transducer error
E23 T2 under limit	53	Temperature range exceeded (2st channel)
E24 T2 T2 above limit	54	
E25 T2 error	57	Temperature transducer error
E26 time synch	4	RTC synchronization error, adjustment by > 2 h was required.
E27 mod.bat.capacity	15	The modem battery is discharged
E28 encoder error	20	Encoder error (SCR or NAMUR)
E29 CRC metrolog.	22	CRC error of metrological part of the FW
E31 FRAM error	26	FRAM memory error
E32 FLASH error	27	FLASH memory error
E33 bar sensor error	46	Integrated barometric transducer error

Table 14: List of events - error messages (Err indication)

Displayed Message	bit	Description
W0 transd. warning	11	Warning alert on one of connected transducers (internal modules SCR, NAMUR, EXT1, SRM or other). Details can be found by reading the parameters of the data logger.
W1		- not used -
W2 battery	13	Memory error in battery pack.
W3 overcurrent	14	Current overload occurred
W4		- not used -
W5 network failure	16	Mains power supply failure
W6	21	- not used -
W7 tamper contact 1	24	Tamper contact 1 active.
W8 tamper contact 2	25	Tamper contact 2 active.
W9 P1 min. limit	34	Pressure user limits exceeded (1 <sup>st</sup> channel)
W10 P1 max. limit	35	
W11 T1 T1 min. limit	39	Temperature user limits exceeded (1 <sup>st</sup> channel)
W12 T1 T1 max. limit	40	
W13 Q1 Q1 min. limit	42	Flow rate at measurement conditions user limits exceeded (1 <sup>st</sup> channel)
W14 Q1 Q1 max. limit	43	
W15	44	- not used -
W16	45	
W17		- not used -
W18		- not used -
W19 P2 P2 min. limit	50	Pressure user limits exceeded (2nd channel)

W20 P2 P2 max. limit	51	
W21 T2 T2 min. limit	55	Temperature user limits exceeded (2nd channel)
W22 T2 T2 max. limit	56	
W23		
W24		- not used -
W25		- not used -
W26		- not used -
W27		- not used -
W28		- not used -
W29 EEPROM m.bat	18	Memory error of the modem battery
W30 m.battery voltage	12	Modem battery voltage low
W31 communication error	28	Communication error
W32 user cover	29	Housing cover opened
W33 ext.power supply of modem	61	External power supply to the modem has failed
W34 metrol.switch	62	Metrological switch is ON
W35 user switch	63	Service switch is ON
W36 volume dif.	47	Volume limit has been exceeded when comparing volume counters
W37 metrolog. cover	60	Cover of metrological part of the device was opened
W38 RTC setting	58	The system time has been set
W39 Primary volume setting	59	The primary volume has been set
M0 no configuration	30	The device is in Not configured state
M1 maintanance	31	The device is switched to Maintenance state

Table 15: List of events - error messages (Wrnr indication)

### 6.9.6 Status Word of the Device

The current status of the device is stored in the 64-bit status word of the device. Each of the monitored status (eg temperature error, pressure error, battery status, etc.) is assigned a fixed bit in the status word. The state of each bit indicates whether the status occurred or not.

**Note**

**If any monitored bit changed, the entire status word is stored in the status archive with a time stamp.**

The status word of the device is also stored in the data, daily and monthly archives. These records store information about whether the bit has reached the active state during the archiving interval. Assignment of a specific status word bit to each monitored event is shown in table 14 and table 15. When viewing the status in the device archives by the operating SW [19] the status word is already displayed in decoded readable form.

## 7 Technical Description of the Device

### Warning

All the connectors in the device contain a mechanical safety lock (item 1) against accidental disconnection.

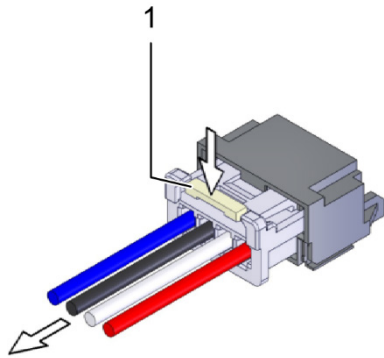

To disconnect the connector, first press the lock to release the connector, then pull the connector gently out of the socket. Never apply force grasping and pulling the cable, it can be damaged.

To re-connect the cable to the device, plug the connector slightly so that the lock snaps into place, then check for the proper connection by a slight pulling on the cable.

### 7.1 Architecture of the Device

The standard version of the device is delivered with a built-in pressure transducer and a connected temperature transducer. The device architecture is based on interchangeable modules that are mounted in the slots of the I/O board (see below) located on the bottom of the enclosure.

The CPU Module (processor board) with the display, keypad, and battery for the device (powering the device except the modem) is located in the top cover of the device. The CPU module is protected by the cover and marked with a metrological seal. In the cover of the board is an opening to access the service switch. Use the service switch to enable/disable the device parameter settings.

At the bottom of the cabinet there is the I/O board of inputs and outputs with terminal blocks for connecting external devices and with slot connectors for connecting of exchange modules used to extend the features of the device.

Connections related to the metrological function of the data logger are protected by covers that are marked with the metrological seal.

### Note

The device is equipped with autodetection of the installed modules.

Modules located in SLOT 0, SLOT 1, SLOT 2 and SLOT 3 are always detected (without any other conditions).

To the detection of SLOT 4 and SLOT 5 modules, the following applies:

- Modems requiring a modem battery (S4-PWR2 module or M2G, M4G modem) can only be detected in these slots with the modem battery connected.
- Other modules are always detected.

## 7.2 Main parts of the device

Fig. 46 shows the main parts of the Prilog 400 / Primus 400 device.

Prilog 400 and Primus 400 are equipped with SLOT 0 to SLOT 5 extension connectors.

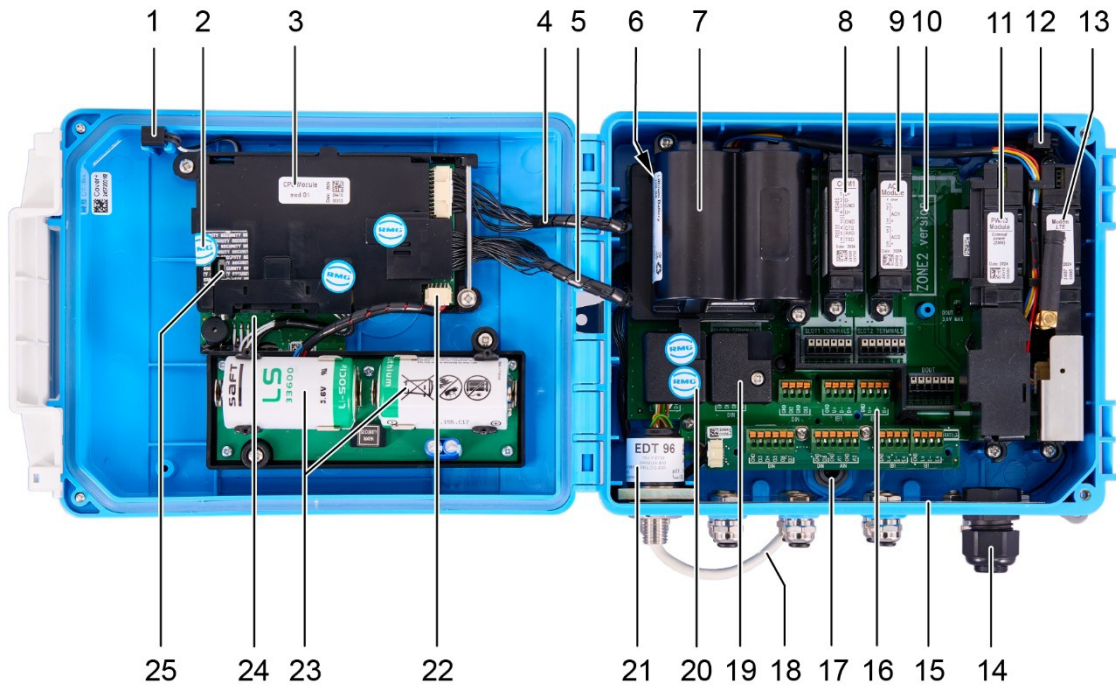

Fig. 46: Main parts of the Prilog 400 device

Item	Designation	Item	Designation
1	device opening sensor	14	cable glands
2	metrological seal of metrological switch cover	15	conductive strip connecting the metal cable glands, cable shields
3	CPU mode	16	I/O board
4	modem cable	17	ventilation grommet with IP68 rating
5	I/O board cable	18	EDT 87 temperature transmitter cable
6	module fitted in SLOT 0 (placed under modem battery in Primus 400)	19	terminal cover for gas meter connection
7	modem battery	20	cover or temperature and pressure transducer
8	module installed in SLOT 1	21	EDT 96 pressure transmitter
9	module installed in SLOT 2	22	device battery connector
10	empty SLOT 3	23	device battery
11	module installed in SLOT 4	24	keypad board
12	device opening sensor	25	service switch
13	module installed in SLOT 5		

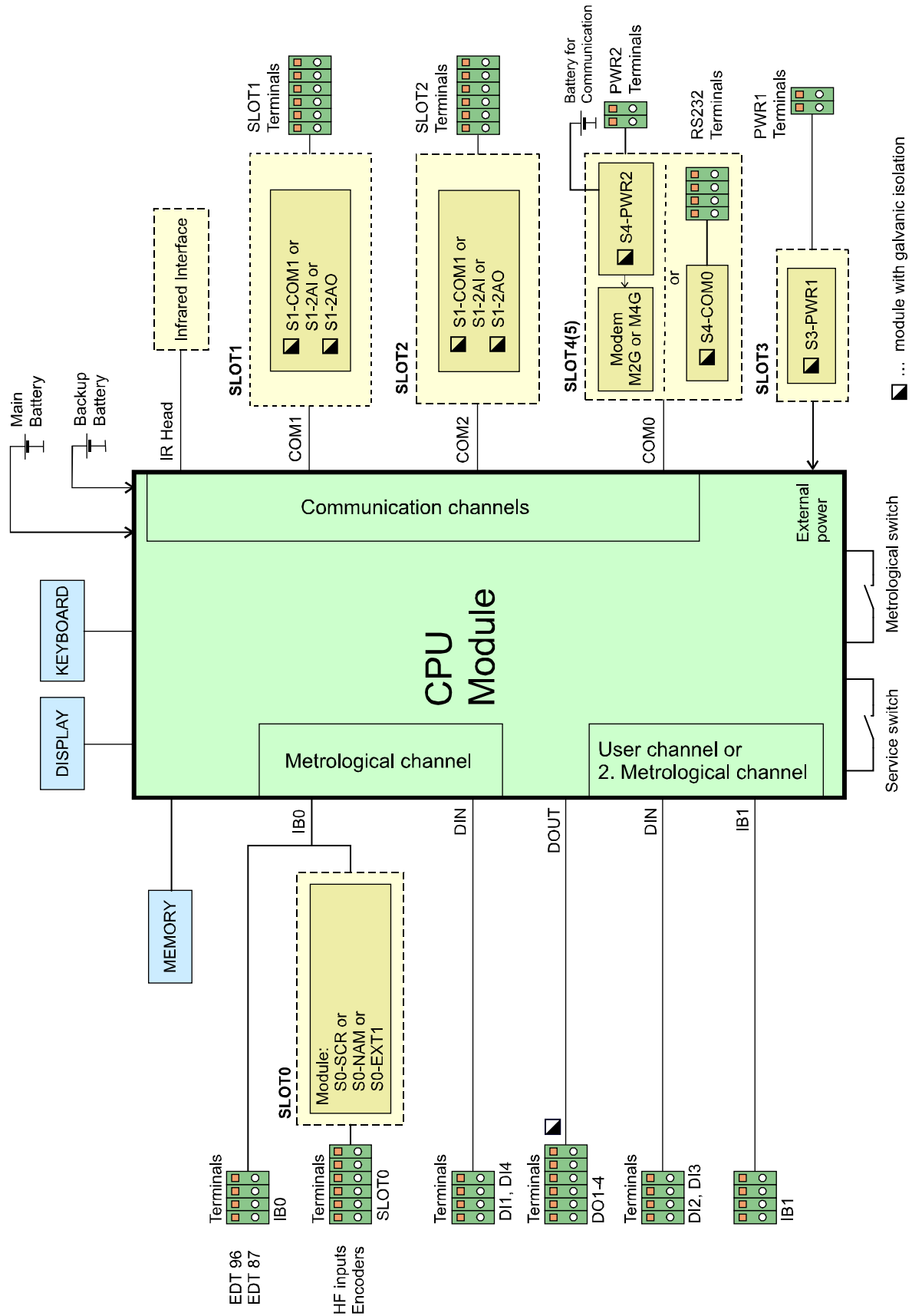

Fig. 47: Functional diagram of Prilog 400

### 7.3 Modules, Principles of Use

The supplied expansion modules are designed for installation into the slots located on the I/O board. Prilog 400 and Primus 400 are equipped with SLOT 0 to SLOT 5. For each module, the manufacturer determines into which slot it can be fitted. Each slot is fitted with a connector into which the module is inserted. The inserted module is fixed in the device by two secure screws.

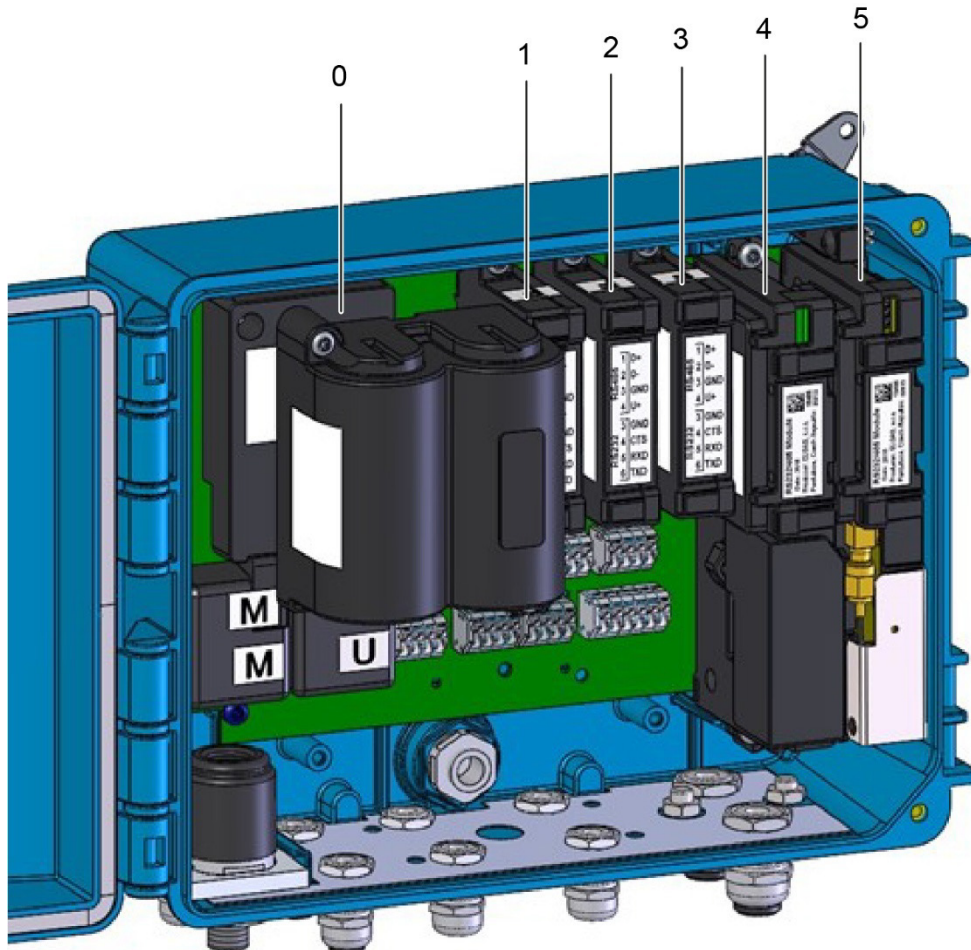

Fig. 48: Arrangement of Prilog 400 slots

Item	Designation	Item	Designation
0	SLOT 0	3	SLOT 3
1	SLOT 1	4	SLOT 4
2	SLOT 2	5	SLOT 5

**⚠ Caution**

A trained person may install or replace modules that are not protected by a metrological seal (i.e. outside of SLOT 0) even in potentially explosive environments, provided that the warnings and procedures described in this document are observed and that all safety standards applicable to products and explosive environments are complied with.

**⚠ Caution**

When handling the modules in the device, first disconnect the device and modem power supply. If external power supply is used, disconnect it first, then disconnect the battery.

Following this procedure, the module replacements may be carried out even in potentially explosive environments. When handling removed modules, be careful so as not to damage them. Put plastic protective caps to the connectors to the empty slots of the I/O board.

**⚠ Caution**

The device and modules are equipped with CMOS components that are sensitive to static charges. Do not touch the outlets of the components and connectors.

When working, do not use synthetic fabrics (including clothing) from which a static electricity spark could arc to the circuit.

### 7.3.1 Installing the Modules

The device design allows additional extension or alteration of the input/output modules (SLOT 1, SLOT 2) and external power supply of the whole device (SLOT 3) and the communication module (SLOT 4).

**⚠ Caution**

A change of the device classification from the point of view of explosion safety is not possible. This must be considered for retrofitting modules.

**Note**

The prescribed tightening torque of the module mounting screws to the I / O board is 0.7 Nm.

**Procedure:**

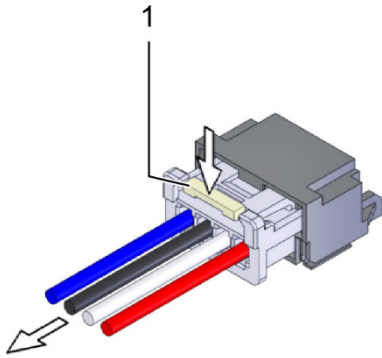

Fig. 49: Release the safety lock

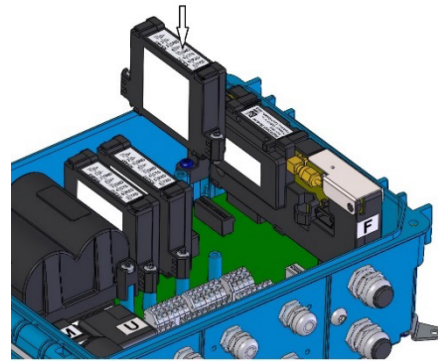

Fig. 50: Insert module

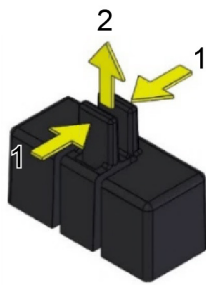

Fig. 51: Removing the end caps

Always disconnect the power supply from the measurement part (processor board) before handling the modules.

- If external power supply is used, disconnect the power supply from the PWR1 terminals.
- Disconnect the battery. Press the lock (fig. 49, item 1) and gently pull the plug to disconnect the connector.
- Unused connectors on the system board are protected by caps. To retrofit a module, first remove the cap. Push the levers gently with pliers to release the latch and remove the cap easily (see fig. 51).
- Attach the module to the posts and press it gently into the connector on the system board (see fig. 50). Tighten the screws. The module is impossible to be installed in a wrong slot. If the module is difficult to plug in, do not use greater force, but check the correct position and orientation of the module.
- Connect the battery or external source terminals.

### 7.3.2 Installing the External Power Supply of the Modem

86

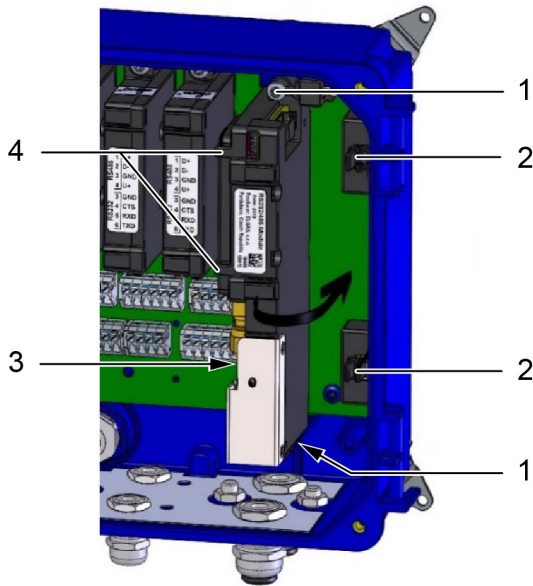

Fig. 53: Install external power supply

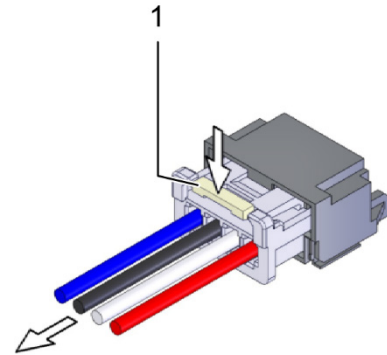

Fig. 52: Release the safety lock

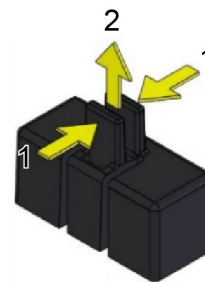

Fig. 54: Removing the end caps

- Press the lock (fig. 52, item 1) and gently pull the cables to disconnect the connector of the modem battery (fig. 53, item 3).
- **The battery-powered modem is located in SLOT 4. To connect an external power supply source, you need to move the modem to SLOT 5 and place the external power module in SLOT 4.**
- Remove the caps of the connector (fig. 53, item 2) in SLOT 5. Using pliers, press gently the levers (fig. 54, item 1) to loosen the catch and release the cap (fig. 54, item 2).
- Loosen the battery cables from the bracket (fig. 53, item 4)
- Loosen the fixing screws (fig. 53, item 1).
- Remove the modem by pulling it perpendicular to the base plate, do NOT tilt the module to the side! An antenna is installed inside the module, which moves together with the module.
- Place the module on the posts of Slot 5 and press it gently into the connector on the system board. Tighten the screws (fig. 53, item 1).
- Install the external power supply module to SLOT 4 in the same way.
- Connect the external source cables to the PWR2 terminals.
- Insert the battery into the PWR2 external power module.

### 7.3.3 Replacement of the Modem

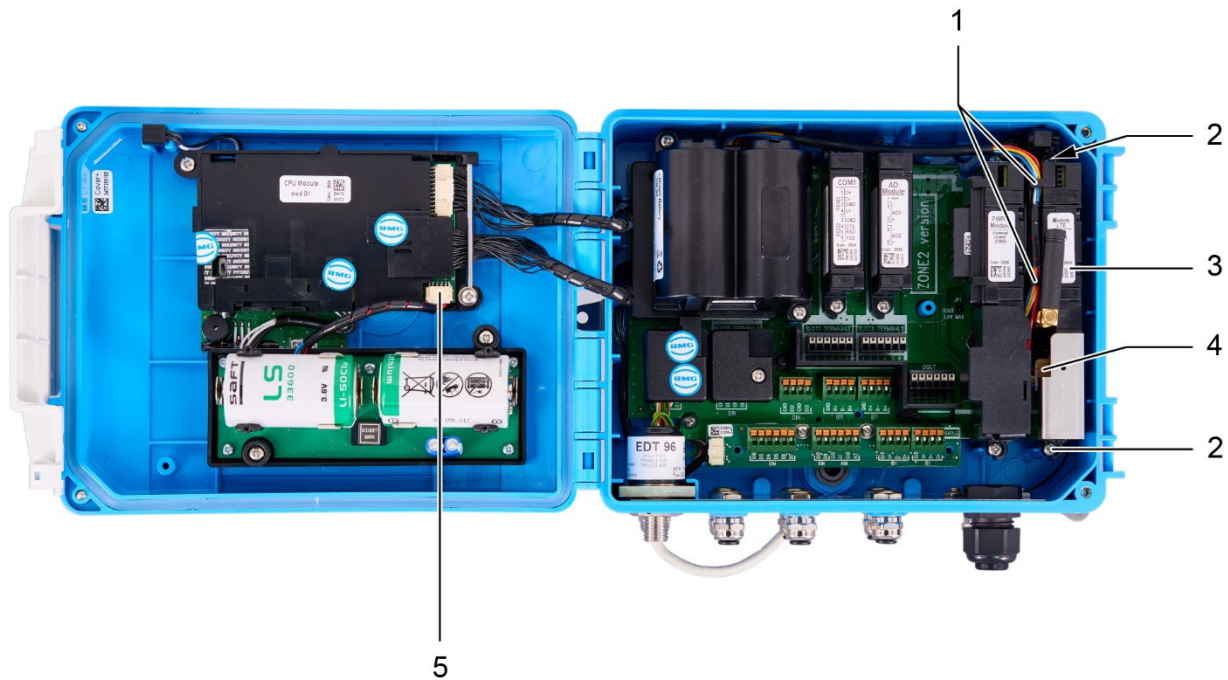

Fig. 55: Modem replacement

- If external power supply sources are used, unplug the power supply from the PWR1 and PWR2 terminals.
- Press the lock and gently pull the cables to disconnect the connectors of both batteries (fig. 55, item 4 and item 5).
- Loosen the battery cables from the bracket (fig. 55, item 1).
- Loosen the fixing screws (fig. 55, item 2).
- Remove the modem (fig. 55, item 3) by pulling it perpendicular to the base plate, do NOT tilt the module to the side! An antenna is installed inside the module, which moves together with the module. If external antenna is used, disconnect its connector from the communication module before removing the module.
- Place the module on the posts and press it gently into the connector on the system board. Tighten the screws (fig. 55, item 2). Pay attention to the correct orientation and position of the module, see Section 5.6.2.
- Connect the battery connectors (fig. 55, item 4 and item 5).
- Connect the cables to the PWR1 and PWR2 terminals of the external power supply.
- Make sure that the battery is connected to the correct connector, see Section 5.6.2.

## 7.4 Power Supply of the Device

### ⚠ Caution

Only batteries prescribed by the manufacturer (see paragraphs 3.4 and 3.10.2) approved by the laboratory for this device and complying with the parameters for explosive environment may be used in the device.

Batteries are sealed by the manufacturer and must not be disassembled for safety reasons.

### ⚠ Caution

Both the device battery and the modem battery can be replaced in a potentially explosive environment.

Only the prescribed type of battery may be used.

### ⚠ Warning

All used connectors in the device contain a fuse against accidental disconnection. When disconnecting, it is necessary to press down first to release the pull-out catch, then pull it slightly.

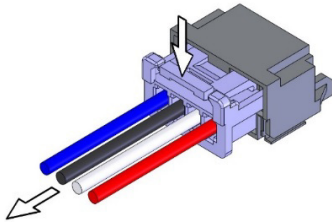

Never pull by force on the cable, it can be damaged. When reinserting, simply insert it slightly so that the lock is visible. Then, make sure to pull it lightly by the cable.

### Note

Discharged batteries fall under hazardous waste category. According to the WEEE Directive (2002/96/EC) and under national regulations, batteries may not be disposed of together with household waste. Discharged batteries are subject to a take-back obligation. Therefore, it is necessary to dispose of the discharged batteries at the point of take-back or at authorized points for the recycling of electrical and electronic waste.

### 7.4.1 Batteries to Power the Device

The device is powered by a **B-03** battery with a nominal voltage of 3.6 V and a capacity of 17 Ah. Instead of this battery, the device Prilog 400 can be equipped with a **B-03D** battery that has a higher capacity (30 Ah).

The modem module is not powered from this battery in the device variant with the modem. Its power supply is provided by its own battery.

During operation, the consumed capacity is measured and calculated. The remaining battery capacity is stored directly in the internal battery memory.

**Note**

If the battery capacity drops to 10% before the expected discharge, the device will alert you of the need to replace the battery (error message **E9**, see table 14).

The battery life depends mainly on the device configuration, the frequency of communication, the time of display illumination and weather conditions.

**Defined conditions for declared battery life:**

- 30 s measurement period (not applicable to encoders)
- archive period of data archive 1 hour
- period of input pulses from the gas meter  $\leq 10$  Hz
- generating output pulses with frequency  $f \leq 1$  Hz
- operating communication (local or remote) with the device for 2 min per day
- service communication (local or remote) with the device for 5 min per week
- firmware update (locally or remotely) once a year
- ambient temperature: -25 °C to +70 °C

Under these conditions, the lifetime of the batteries supplied for typical Prilog 400 configurations is shown below:

#### 7.4.1.1 Prilog 400 Data Logger Basic Variant

**a) Basic configuration**

Battery life	With the display OFF
Lithium battery B-03	11 years
Lithium batterie B-03D	15 years

*Backup battery lifetime: 15 years backup time (including use without main battery for 3 years)*

**b) Basic configuration with online communication**

Communication via RS232 or RS485 interface, transfer rate 115 kBd:

Battery life	With the display OFF	
Actual values reading period	5 s	15 s
Lithium battery B-03	---	5 years
Lithium battery B-03D	5 years	10 years

Declared battery life applies to the HW device configurations:

**Prilog 400 HW Configuration:**

- IB0: 1x EDT 96, 1x EDT 87 (metrological transducers)
- IB1: not fitted
- SLOT0: not fitted
- SLOT1: S1-COM1 - RS232/RS485 interface
- SLOT2: not fitted
- SLOT3: S3-PWR1
- SLOT4: S4-PWR2 or modem
- SLOT5: Modem or not fitted

**7.4.1.2 Prilog 400 data logger variant with connected NAMUR or SCR+ encoder**
**a) Encoder reading period 1 hour**

Battery life	With the display OFF
Lithium battery B-03	10 years
Lithium battery B-03D	15 years

*Backup battery lifetime: 15 years backup time (including use without main battery for 3 years)*

**b) Encoder reading period 30 s**

Battery life	With the display OFF	
Encoder type	NAMUR	SCR+
Lithium battery B-03	---	5 years
Lithium battery B-03D	5 years	9 years

*Comment:*

- 1) *In this mode, the battery life depends mainly on the power consumption of the connected encoder. The consumption of the encoder of different manufacturers may be different. The above lifetimes apply to encoders manufactured by Elster, RMG and FMG.*
- 2) *The encoder reading period is limited, see section 9.4.*

Prilog 400 HW Configuration:

- IB0: 1x EDT 96, 1x EDT 87 (metrological transducers)
- IB1: not fitted
- SLOT0: S0-NAM or S0-SCR module with encoder connected
- SLOT1: S1-COM1 - RS232 / RS485 interface
- SLOT2: not fitted
- SLOT3: S3-PWR1
- SLOT4: S4-PWR2 or modem
- SLOT5: Modem or not mounted

**7.4.1.3 Prilog 400 other variants**

Contact the manufacturer to determine the battery life of a different HW/SW configuration of the device that is not stated here (see section 6.9).

**Note**

If the device needs to be operated with a higher consumption than in the defined mode, it is necessary to take into account the more frequent replacement of the battery or, in the case of Prilog 400, to use the external power supply.

**7.4.2 Replacing the Battery**

It is advisable to disconnect the discharged battery as soon as possible.

**Note**

The device indicates discharged battery by E9 error message in the device diagnostics (see Section 6.9.5).

**Note**

All data in the device, archives and parameter settings are stored in non-volatile (energetically independent) memory and will remain intact even if the device is disconnected from the power supply, including the disconnection of the backup battery.

**Note**

During the battery replacement, the device does not measure pressure or temperature, but counts incoming LF pulses (however, the pulse conversion is not carried out before the battery is connected), and the real-time clocks operation is ensured.

**Note**

The prescribed tightening torque of the batteries mounting screws to the device is 0.7 Nm.

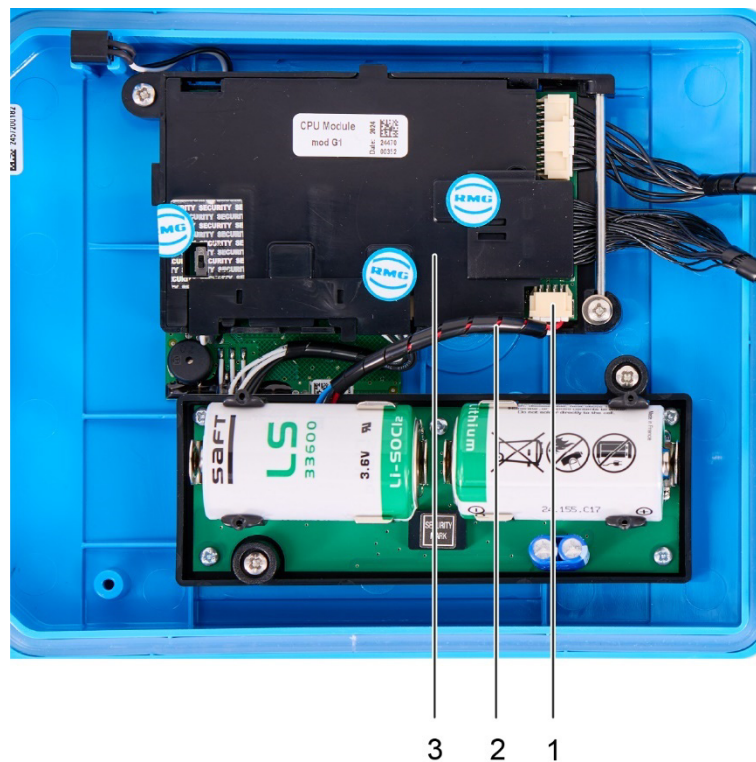
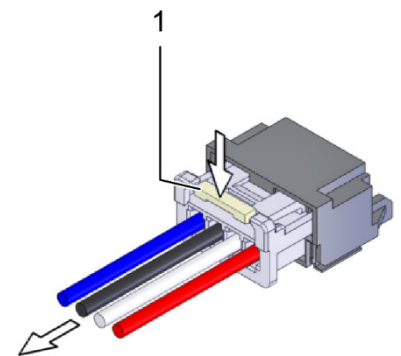

Fig. 56: Main battery

Item	Designation	Item	Designation
1	Connector	3	CPU module, processor board
2	Battery cable		

**To replace the battery:**

- Press the mechanical connector lock (item 1) and pull the cables gently to disconnect the battery connector (fig. 56, item 1) from the CPU module.
- Loosen the battery fixing screws.
- Remove the battery and replace it with a new one. Fix the battery in position by the screws.
- The battery cable with connector (fig. 56, item 2) must be plugged into connector (fig. 56, item 1) on the processor board (fig. 56, item 3).
- When the battery has been connected, the device is automatically turned on.



### 7.4.3 Battery to Power the Modem

#### Note

Discharged battery of the modem is indicated by the E27 error message in the device diagnostics; low voltage of the modem battery is indicated by the W30 warning message.

93

The status of the modem battery is automatically checked by the machine every 2 minutes. Replacing the battery of the modem is therefore automatically registered within 2 minutes or after resetting the device.

During modem operation, the consumed capacity is measured and calculated. The remaining battery capacity is stored in the internal memory of the battery.

Each type of applied modem requires the appropriate battery type.

Type of the modem	Battery designation	Battery life *)	Battery voltage	Battery capacity
M2G internal 2G modem	HB-03	6 years	3.0 V	12 Ah
	HB-03D	11 years	3.0 V	20 Ah
M4G internal LTE modem	HB-04	6 years	6.0 V	12 Ah

\*) The specified battery life applies to the following mode of operation:

- GSM/GPRS data transmission once a day (modem ON for 2 minutes per day on average)
- GSM/GPRS service window once a week (10 minutes ON, average 1 minute of communication each week)
- remote download once a year
- Ambient temperature -25°C to + 25°C
- Signal strength 80%

Battery life depends mainly on the mode of use, the signal strength at the point of deployment and the ambient temperature:

- Battery life decreases with higher ambient temperatures (to ca 90% at 50°C, to 80% at 70°C).
- Battery life decreases with decreasing signal strength (to ca 60% at 15% signal strength).

### 7.4.4 Replacing the Modem Battery

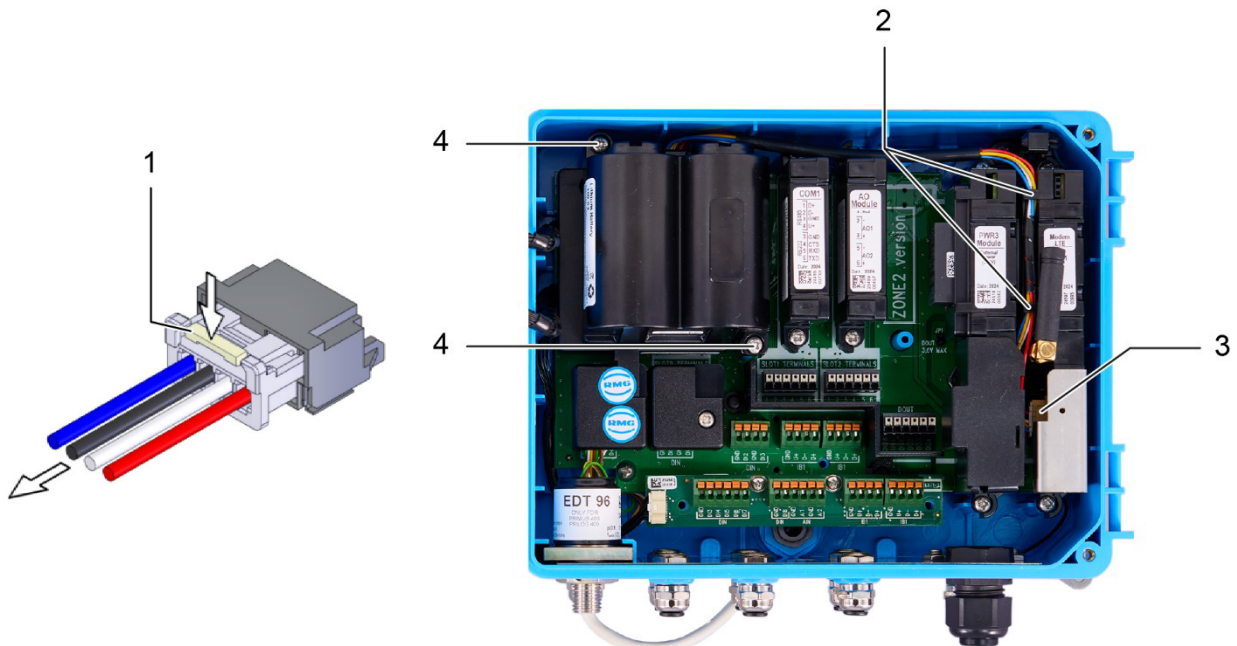

Fig. 57: Replacing the modem battery

Item	Designation	Item	Designation
1	Safety lock connector	3	Modem battery connector
2	Bracket for battery cable	4	Modem battery mounting screws

- Press the lock (fig. 57, item 1) and gently pull the cables to disconnect the connector of the modem battery (fig. 57, item 3).
- Loosen the battery cables from the bracket (fig. 57, item 2)
- Loosen the mounting screws (fig. 57, item 4).
- Remove the battery and replace it with a new one. Tighten the screws.
- Hitch the cables under the bracket (fig. 57, item 2) and connect the connector (fig. 57, item 3).
- Connect the cables into PWR2 terminals of the modem external power supply.
- Make sure that the battery is connected to the correct connector, see Section 5.6.2.

### 7.4.5 Back-up Battery

The battery serves to backup important functions when the main battery is discharged or being replaced. The back-up battery is located in a holder on the processor board (CPU module) under the cover. The back-up battery can be replaced by an authorized service centre after disrupting the metrological seal and the manufacturing mark (the replacement must not be performed in potentially explosive atmospheres). Only approved battery types may be used.

The battery life of the back-up battery is specified in Section 3.4.

7.4.6 External Power Supply

<b>Note</b>
<p><b>External power supply can be used for Prilog 400.</b></p> <p><b>The external power supply to the device does not provide power to the internal modem. For an internal modem, separate external power supply must be used.</b></p>

The Prilog 400 can be powered from an external intrinsically safe source. If the device is equipped with an internal modem, the device can also be equipped with an external power supply for the modem.

External power is recommended where the operating mode of the device or modem is set to have an increased current consumption from the batteries, thus shortening the batteries life.

**Using external power supply for the device (its measuring part) is necessary:**

- When using EXT1 module with NAMUR HF pulse input

**Using external power supply for the device is recommended:**

- For frequent communication (more than once a day),
- When longer time ON of the modem than specified in paragraph 7.4.3 is requested

In order for the device or modem to be powered externally, it must be fitted with an appropriate plug-in module to which an external intrinsically safe source is connected. The supplied intrinsically safe sources must be powered from a 12 Vdc source.

<b>Note</b>
<p><b>The device batteries and modem batteries must be inserted and connected in the device even when external power supply is used.</b></p> <p><b>In the event of the external power supply failure, the device and the modem are switched automatically to battery operation. In this case, the batteries serve as backup power supply.</b></p>

External power supply	External power supply module		IS source	
	Module	Installation	Type of source	Installation
Device	S3-PWR1	SLOT 3	PS-E, PS-E/A	Out of potentially explosive atmosphere
Internal modem	S4-PWR2	SLOT 4	PS-M, PS-M/A	Out of potentially explosive atmosphere

Table 16: External power supply, components required

The wiring diagram for the external supply of the device is specified in Section 5.5.7.1.

The wiring diagram for the external supply of the modem is specified in Section 5.5.7.2.

## 7.5 Digital Outputs, Modified Use

Prilog 400 and Primus 400 have 4 digital outputs DO1 to DO4. These outputs run to the DOUT terminal block of the input/output board (I/O board). All outputs are galvanically isolated and are of the open collector type.

The basic use of these outputs required feeding these outputs externally by supplying voltage to the U0 + terminal of the DOUT terminal block. In this case, the shorting jumper JP1 must not be fitted to the I/O board.

For pulse outputs, however, it is possible to set a special mode of use for DO1 and DO2 outputs where these outputs can be operated as pulse outputs without power supply at terminal U0 +. This method of use requires a shorting jumper JP1 on the I/O board (see fig. 58).

**Attention: this mode reduces the operating ranges of the DO1 and DO2 outputs**  
(see table 17)

Parameter	Without shorting jumper JP1	With shorting jumper JP1
DO1 and DO2 output option	Pulse, binary, data	Pulse output
Supply voltage (terminal U0+)	3.6 V – 15 V	-----
Output voltage	2.7 V – 15 V	3.0 V – 3.6 V !!!
Output current	3 $\mu$ A – 100 mA	3 $\mu$ A – 1 mA
Max. frequency	1 Hz	1 Hz
Pulse width (closed output)	5 ms – 25 s	5 ms – 50 ms

Table 17: Operating parameters of DO1 and DO2 outputs depending on shorting jumper JP1

### Note

If the supply voltage is not applied to the U0 + terminal, the DO3 and DO4 outputs are disabled in the case of Prilog 400.



Fig. 58: Placing JP1 Jumper on I/O Board

## 7.6 Internal Modem, Using External Antenna

The internal M2G, M4G modem is powered by a stand-alone HB-03/HB-03D battery. The modem is fully controlled by the device parameters. Due to the current consumption of the modem, it is necessary to choose the mode and timing of the transmitted data and to control the switching ON and OFF of the modem with respect to the modem battery. For the Prilog 400, the internal modem can also be powered from an external power supply (PS-M, PS-M/A) using the S4-PWR2 module.

### 7.6.1 Using the Device with an External Antenna

The internal M2G and M4G modems are equipped with an integrated antenna that is part of the M2G or M4G modem. The antenna is located under the modem module cover and is connected to the modem board via a standard SMA connector.

In locations with poor signal quality, the internal antenna can be disconnected and an external, more powerful antenna, attached to the coaxial cable outside the device, can be connected. This modification is based on the installation of a HF cable adapter that interconnects modem antenna outlet with outer antenna plug. The required part - HF cable adapter, see fig. 60 - can be ordered as an option.

An external antenna (optional) is connected to the SMA (f) panel connector at the bottom of the device enclosure.

The external antenna may be located in a potentially explosive zone or in a safe environment.

**Warning**

When designing the installation and use of an antenna other than the supplied standard one, especially when located outside a potentially explosive zone, the external antenna must be installed so that it is in the protection area of a lightning protection (see EN 60079-14 and EN 62305 3).

98

The maximum cable length for the external antenna is 10 m.

**7.6.2 Modifying the Device for Connecting an External Antenna to the Modem**

Fig. 59: Connecting an external antenna

**Procedure:**

- If external power supply of the modem is used, first disconnect power source from PWR2 terminals.
- Press mechanical lock of the connector on the modem battery cable and pull the cables gently to disconnect the modem battery.
- Put SIM card cover (fig. 59, item 3) to the vertical position, open it slightly, and remove from the modem plastic cover.
- Hold the fixed part of the connector (fig. 59, item 1) with a flat key size 7 to prevent the part from slipping out of the printed circuit board, and release the nut of the inner antenna connector (fig. 59, item 2) nut with a key size 8.
- Unscrew the connector nut (fig. 59, item 2) and insert it into the holder in the cover (fig. 59, item 6).
- Remove the blind cap (fig. 59, item 5) at the bottom of the enclosure.
- Install the HF cable reducer. Insert the panel connector of the HF cable reducer with the

rubber O-ring into the blind cap opening (fig. 59, item 5) and fasten it outside the enclosure using a nut and a washer. Tighten the nut gently (0.7 Nm), remember to hold the fixed part of the connector with the key. Then connect the other end of the HF cable reducer to the connector on the modem board. Feed the cable through the slot opening (fig. 59, item 4) in the modem housing.

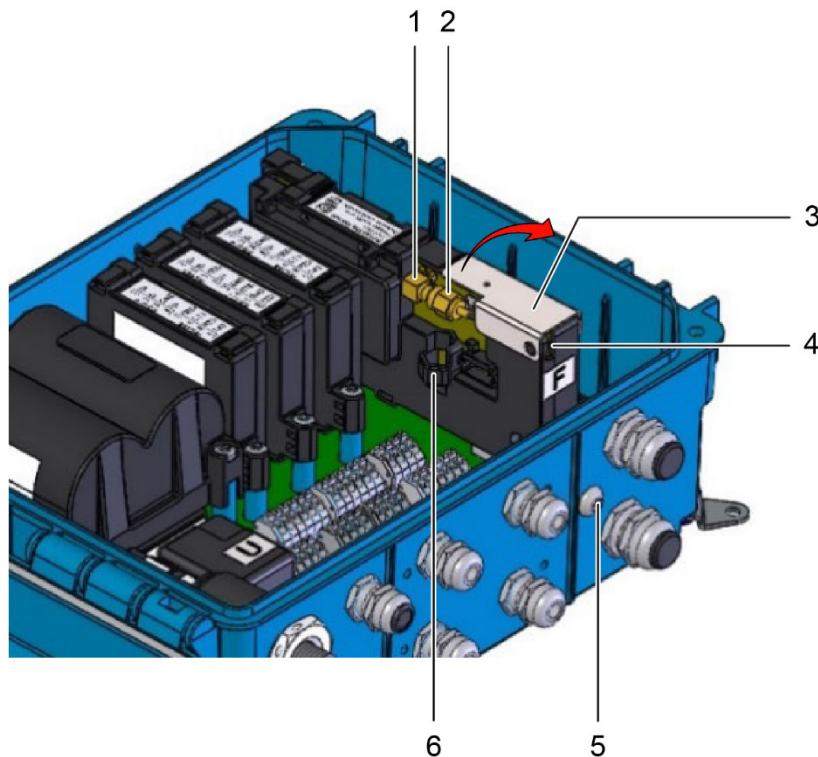
- Put the SIM card cover (fig. 59, item 3) back and close it.
- Reconnect the modem battery connector.
- Connect the external power supply to the PWR2 terminals of the external power supply of the modem.



*Fig. 60: External antenna cable adapter*

## 7.7 Software

The device software (firmware, FW) is divided into 3 parts. The first part ("Loader") is used to ensure that the firmware is uploaded when it is updated.

The second part of the firmware ("Metrolog") includes software for the metrological functionality of the device, display control and keypad control, metrological data security routines and control mechanisms for error statuses detection.

The third part of the firmware ("App") contains the rest of the firmware - communication protocols, communication channel management, superstructure functionality, etc.

Each part of the FW is identified by the version number and the checksum. The version designation is stored in the form of a string; it is a decimal number with two decimal places. The version and checksum "Loader" and "Metrolog" are specified in the certificate, versions can only be modified by the notified body with official approval. Changing in version unit number means a major change, changing the decimals indicates a version with minor changes or bug fixes.

### 7.7.1 Downloading Application Firmware Using "Remote Download" Method

Using this method, you can load new firmware to your device in accordance with the **Welmec 7-2 Extension D** recommendation. The loaded firmware is secured with a **digital signature**, separately in each section. This is to check the integrity of data, the authenticity and also the specificity of the device. The upgrade process is divided into several phases, delayed start of the firmware activation can be set. Information on processing of each individual phase of loading is recorded in the settings archive.

Downloading the FW is not bound to a specific communication protocol or specific PC software, and can be performed via any communication channel. For recording, the firmware is divided into two parts; either the "App" part or the "App" part together with the "Metrolog" can be downloaded.

The digital signature contained in the application firmware file (\*.srec) confirms that standard testing has been performed in the factory and that the "Metrolog" module complies with the valid certificate of the relevant notified body.

### 7.7.2 Storing Data in the Device

Various memories (internal processor RAM, internal FLASH processor, SPI FRAM and SPI dataFLASH) are used to store data in the device.

All the archives and counters are stored in 16MB **non-volatile** SPI dataFLASH memory. Important archives, counters and parameters are additionally backed up in other memories. All data is properly secured. Irregular errors are indicated in the internal diagnostics of the device. The backup battery in the device is used to back up the RAM and the RTC circuit remains in operation. The pulses are counted at the LF inputs.

## 7.8 Principle of the Function

### 7.8.1 Disturbed Quantity Counters

For calculation under error conditions (i.e. because of a device error or in case of exceeding the approved lower or upper limits), the disturbed quantity counter at measurement conditions ( $V_{ms}$ ) is installed in the device.

These counters are coupled with the main counters under undisturbed conditions.

A detailed description of the behaviour of the device under undisturbed and error conditions is described in Section 8.3.1.

### 7.8.2 Volume Correction under the Measurement Conditions

The device is equipped with the option of compensating the gas meter errors according to the correction profile data specified in the gas meter test report. This possibility to use the corrected volume  $V_c$  is in accordance with EN 12405-1 + A2. The function and the  $V_c$  parameter can be added by the manufacturer or at the ASC level. If this function is used, it must be ensured that the error rate profile of the gas meter in relation to the flow rate  $Q$  corresponds to the actual operating conditions.

The meter error is corrected using the  $f(Q)$  function. For the corrected volume, the following applies:

$$V_c = V_m \times f(Q)$$

where:

$V_c$	...	Corrected volume at the measurement conditions (volume corrected based on the correction profile of the gas meter)
$V_m$	...	Volume at the measurement conditions (primary volume)
$Q$	...	Flow rate at the measurement conditions (primary flow rate)

The linear interpolation is used as interpolation method to determine values between the calibration points.

#### Note

The gas meter correction data file is uploaded to the device using the operating program [19].

Gas meter correction values are stored in a file as a table. The table can contain up to 10 flow-dependent correction values.

Information on entering the correction profile of the gas meter in the device is stored in the settings archive.

## Conditions for using Volume Correction

The conditions are in accordance with the requirements of EN 12405-1 + A2:

The correction is used if only the gas meter measures at least 10 pulses per second at  $Q_{min}$ . Below  $Q_{min}$ , the correction is not applied, and the value of the correction factor specified for  $Q_{max}$  is used above  $Q_{max}$ .

102

It follows from these conditions that the correction can only be applied to gas meters with a HF pulse sensor and in the connection with Prilog 400 type.

# 8 Metrological Features

## 8.1 Temperature Measurement

To measure temperature, the device uses the EDT 87 digital transmitter with a PT1000 temperature sensor.

Mechanically, the transducer consists of a sensor in a 5.7 mm stainless steel shank with a length of 50 mm from which the cable is routed. A part of the cable is a plastic cylindrical case with electronics.

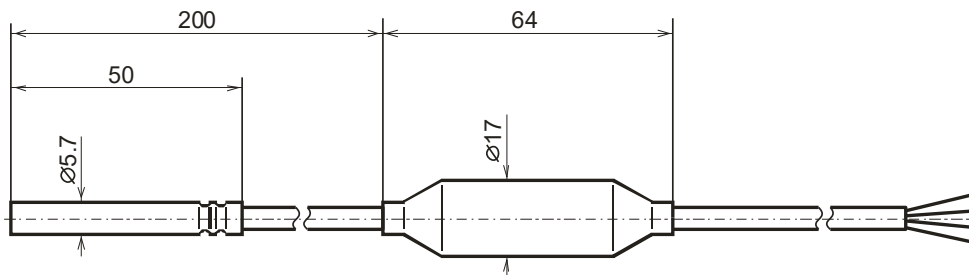

Fig. 61: Transducer dimensions

The temperature is measured using a platinum resistance sensor whose output signal is fed to an analogue-to-digital high-resolution corrector input. After converting to digital, the data is processed by a microprocessor that corrects nonlinearity based on calibration data. The calibration data is stored to EEPROM memory when the transducer is manufactured. The transmitter communicates with the device via the RS485 communication interface.

The temperature measurement range is -25°C to +70°C. The measurement period is common to both temperature and pressure measurements and can be set by the user from 1s to 30s. The temperature measurement units are selectable by end user.

The temperature sensor replacement is protected by the manufacturer's seal (metrological seal) and can only be performed by an Authorized Service Centre (ASC).

When configuring the device, the user must enter a constant parameter **Substitute Temperature** in the device. This value is used instead of the measured temperature value in the following cases:

- the measured temperature deviated from the measuring range
- there is a malfunction of the temperature measurement.

## 8.2 Pressure Measurement

The pressure is measured using the digital EDT 96 transducer. The transducer includes a piezo-resistive silicon sensor with a durable stainless-steel diaphragm. The device electronics corrects the non-linearity and temperature dependences of the pressure transducer based on the calibration data stored in the transducer memory. The measuring range of the pressure transducer must be specified by the customer when ordering the device. The supplied pressure ranges are specified in Section 3.5.2.

The measurement period is common for both temperature and pressure measurements and can be set by the user within the range from 1s to 30s. The pressure measurement units are adjustable.

The temperature transducer replacement is protected by the manufacturer's seal (metrological seal) and can only be performed by an Authorized Service Centre (ASC).

When configuring the device, the user must enter a constant parameter **Substitute Pressure** in the device. This value is used instead of the measured temperature value in the following cases:

- the measured pressure deviated from the measuring range
- the device has been manufactured without pressure transducer
- there is a malfunction of the pressure measurement.

## 8.3 Volumes Measurement and Calculation

To measure and calculate volumes, the following counters are used for each channel in the device:

$V_m$	-	Volume counter under the measurement conditions (primary volume)
$V_c$	-	Corrected volume under the measurement conditions (volume corrected based on the correction profile of the meter)
$V$	-	Volume $V_m$ or $V_c$
$V_s$	-	Operating volume counter at error conditions (disturbed quantity)

Table 18: Volume counter

### 8.3.1 Activities at Error Conditions Occurrence

In the event of error conditions, along counting the pulses into the volume counter at measurement conditions ( $V$ ), the device starts to count the pulses into the disturbed quantity volume counter ( $V_s$ ).

If the corrected volume  $V_c$  is used, the primary volume counter at error conditions  $V_c$  can be related to  $V_m$  or  $V_c$ .

### 8.3.2 Respecting the Change of the Gas Flow Direction in the Gas Meter

A gas meter equipped with two phase-shifted LF rotary sensors allows detecting the flow direction of the gas.

When detecting the gas flow directing while respecting the change of direction, the data logger processes data from the meter in the following way (Fig. 62):

- If the primary volume  $V_m$  addition is positive, the volume is processed following the standard procedure (i.e. the increasing the values of counters  $V_m$  and  $V_{ms}$ )
- If the direction of rotation of the meter is changed, the device remembers the reading of the primary volume counter  $V_m$  (gas meter reading) at which the gas flow direction has been reversed. If gas flows back, only the value of the primary counter  $V_m$  (and  $V_{ms}$ , if applicable) is updated. All the other counters do not change the reading.

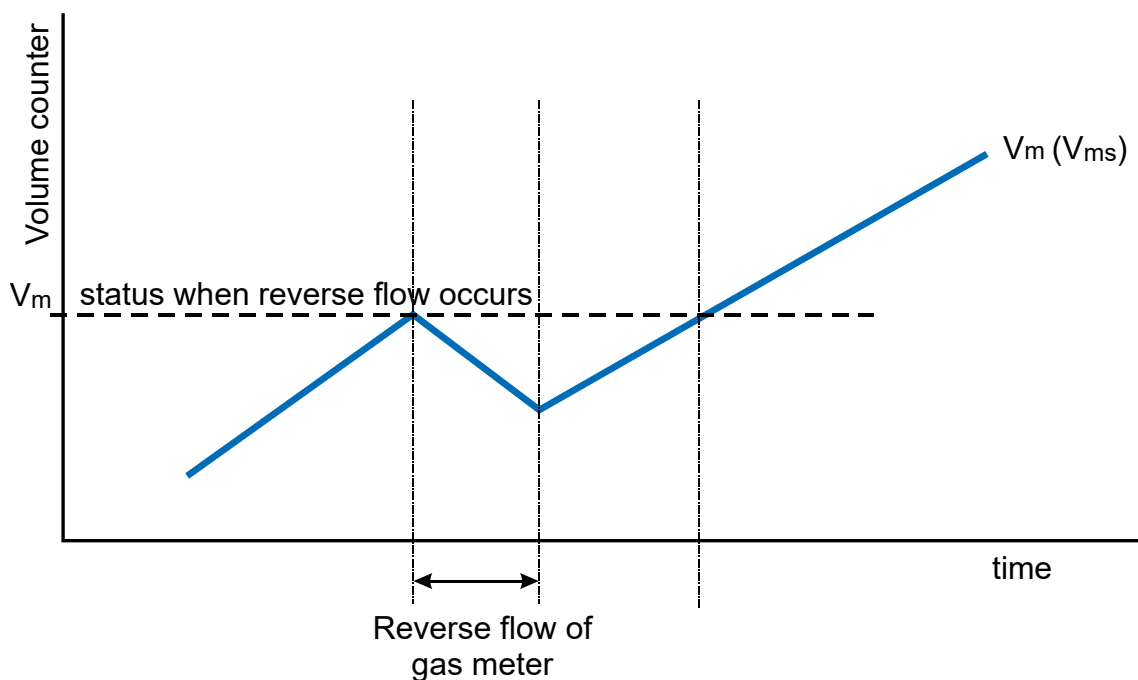

Fig. 62: Processing the volumes at the gas meter revers rotation

## 9 Connecting Inputs

The **Prilog 400** has 4 digital inputs in the basic version, marked DI1 to DI4. Other inputs can be added to the device via plug-in modules.

Digital inputs can be set by the operating SW as binary or LF pulse. The electrical connection of the meters is described in Section 5.5.2.

### Prilog 400, Primus 400

Inputs	Module	Terminals	Pulses	Indication of the gas meter rotation direction	Binary	Encoder
Digital input	Basic design	DI1	LF	LF direction	✓	---
		DI4	---		✓	---
		DI2	LF	---	✓	---
		DI3	LF	---	✓	---
	S0-EXT1	DI1	HF (NAMUR)	HF direction	✓	NAMUR
		DI2	HF (NAMUR)		✓	NAMUR
		DI3	LF	LF direction	✓	---
		DI6	LF		✓	---
		DI4	LF	LF direction	✓	---
		DI7	LF		✓	---
		DI5	LF	LF direction	✓	---
		DI8	LF		✓	---
	S0-NAM		---	---	---	NAMUR
	S0-SCR		---	---	---	SCR

Table 19: Options of digital inputs for the Prilog 400 device

Input	Module	Terminals	Mounting options
4-20 mA analogue (passive)	S0-EXT1	AI1	SLOT 0
		AI2	
4-20 mA analogue (passive)	S1-2AI	AI1	SLOT 1
		AI2	SLOT 2

Table 20: Options of analogue inputs for the Prilog 400 device

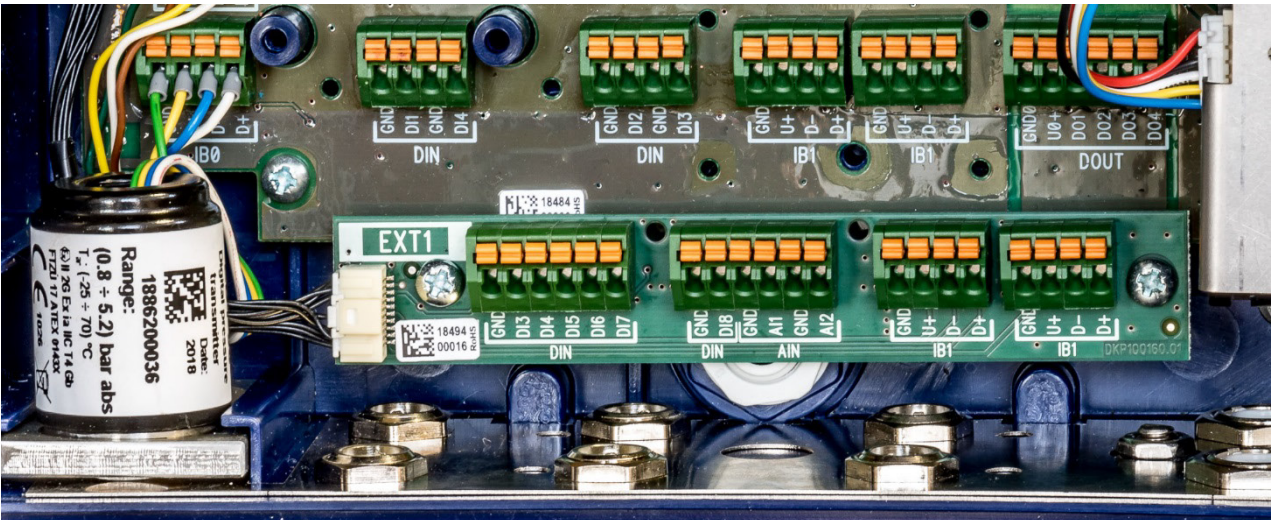

Fig. 63: EXT1-T add-on terminal board for S0-EXT1 module

## 9.1 LF Pulse Inputs

There are used to count pulses from the gas meter. For these inputs, flow measurement function can be selected. The backup battery ensures that the counter readings and the LF input pulses count are maintained even when the battery is discharged or replaced. After the power supply connecting, the impulses read during the voltage outage of the supply battery are added to the spare counters.

### **Changing the Measurement Units, Setting the Gas Meter Constant**

Pulse input measurement units can be changed by the operating SW [19]. The gas meter conversion constant and the gas meter serial number can be set using both the operating SW and the device keypad. When setting the gas meter constant value, only decimal multiples or fractions within the range of 0.001 to 1000 should be used.

Note: We recommend always to use external power supply when using HF pulse inputs. Running on full battery operation is not always recommended.

## 9.2 Binary Inputs

These inputs are used to scan the input signals with the possibility to detect the state "closed" (i.e. log 0) or "open" (log 1). The device allows to evaluate binary inputs from potential-free outputs (reed contact or open collector).

By setting the parameters, the user can select the displayed actual values, save changes to these entries in the archive, the displayed message for log. 0 and log. 1 statuses and the active signal level.

### 9.3 HF Pulse Inputs (NAMUR)

These inputs are available on Prilog 400 with S0-EXT1 module. For these inputs, flow measurement function can be selected. The backup battery ensures that the counter readings are maintained when the external power supply fails even when the main battery is discharged or replaced, but it does not provide for pulse counting in this case.

#### ***Changing the Measurement Units, Setting the Gas Meter Constant***

Pulse input and gas meter measurement units can be changed by the operating SW. The gas meter constant and gas meter serial number can also be set from the device keypad.

Note: We recommend always to use external power supply when using HF pulse inputs. Running on full battery operation is not always recommended.

### 9.4 Connecting a Gas Meter with an Encoder

A gas meter equipped with an encoder can be connected to the data logger. The meter counter reading is transferred to the data logger in digital form. To connect an encoder, it is necessary to install the module into SLOT 0 according to the type of encoder. Two types of encoders, a NAMUR encoder and an SCR encoder, are supported.

The use of both types of encoders is metrologically approved by EC Type Certificate TCM 143/18-5562.

The data logger is connected with the encoder by a shielded two-wire cable. The electrical connection of the encoders with the device is described in Section 5.5.2.4. When making the connection, the signal polarity must be respected.

The encoder data is transmitted to the data logger in the measurement frequency. Setting a short measurement frequency shortens the battery life. Section 7.4.1 shows the battery life when using encoders.

The period of reading the data from the gas meter encoder connected to the instrument by means of an add-on module located in the SLOT 0 position is limited according to the type of encoder and the type of module used:

Encoder type	Module (SLOT 0)	Reading period
SCR+	S0-SCR	10 s – 1 hour
NAMUR	S0-NAM	1 min – 1 hour
	S0-EXT1	10 s – 1 hour

*Table 21: Encoders – limitation of reading period*

#### 9.4.1 Device Specifics when using the Encoders

When the encoder is connected, the data communication with the data logger takes place on a two-wire cable. In addition to transferring the absolute value of the gas meter counter reading, additional information from the meter can be transmitted (serial number, gas meter constant, number of nines to reverse the counters, etc.). This additional information is downloaded by the control firmware of the data logger and used to parameterize the device.

If there is a communication error between the data logger and the encoder, then:

- The "\*" flag (asterisk) shows on the display of the data logger at the actual primary volume value.
- If the communication error lasts for more than 10 minutes, the volume difference is added to the counter after the communication has been restored.

The manual setting of the primary volume  $V_m$  value is blocked for inputs connected to an encoder.

109

## 9.4.2 Gas Meter Installing and Replacing

When the gas meter is connected to the data logger, the current reading of the meter is transferred to the corrector, i.e. the state  $V_m$  may change abruptly. In order that this abrupt change is not falsely reflected, the following procedure should be followed:

- In the operating SW [19] running on the PC, display the device parameters, select the "SCR Encoder" object and press the "Encoder Replacement" button. During the exchange of the encoder, the processing of volume from the meter will be stopped. (You also need to follow the instructions displayed on the PC screen).
- Connect the encoder physically to the data logger.
- After connecting the encoder, complete the installation/replacement with the OK button.

During the installation/replacement (i.e. from point 1), no increments are added to the related counters, and the corresponding counter is marked with an exclamation mark on the display. If point 3 of this procedure is not performed within one hour of the start of the replacement, the replacement mode will automatically be terminated in the operating program.

## 10 Communication with the Device

In order to communicate with other instruments, the device is equipped with several communication devices:

110

	Prilog 400
Optical interface for IR head	1
RS232/RS485 integrated communication line	-----
RS232/RS485 communication line, module S1-COM1	2
RS232 communication line, module S4-COM0	1
Internal modem	1 **)

\*\*) Using plug-in internal M2G or M4G modem

Table 22: Communication options of the devices (max. possibilities)

The table specifies the maximum numbers of communication interfaces for the plug-in modules. An external modem can be connected to RS232 communication lines (for details see 10.3.1)

### Note

The devices can operate up to two modems.

A combination of 1 internal modem and 1 external modem is allowed, or 2 external modems connected to RS232 communication lines can be used.

### ⚠ Caution

Signals on all RS232/RS485 communication terminals of the device are intrinsically safe. Common communication devices connected to the device must be connected via a suitable communication barrier (B-RS).

The recommended wiring diagram is shown in Section 5.5.8.

The speed settings and communication protocol type for each interface can show on the device display. It is also possible to change the setting from the device keypad (see 6.7).

The internal modems are supplied in the following versions:

Designation	Description	Battery type	Note
<b>1. Modems for 2nd generation networks (2G)</b>			
M2G	Data transfer in GSM or GPRS mode	HB-03, HB-03D	
<b>2. Modems for 4th generation networks (4G)</b>			
M4G, LTE-Cat1E	LTE cat. 1, European design	HB-04	
M4G, LTE-Cat1US	LTE cat. 1, European design	HB-04	
M4G, LTE-CatM1US	LTE-M1, European design	HB-04	
M4G, LTE-CatNB	LTE-NB, European design	HB-04	in progress

#### Baud rate setting ranges

	Baud rate
Optical interface for IR head	2 400 Bd – 115 200 Bd
Internal modem (Baud rate between the device and the modem)	2 400 Bd – 115 200 Bd
RS232/RS485 communication line	2 400 Bd – 115 200 Bd

In the current firmware version, the device is equipped with several communication protocols. The device is extendable by additional protocols according to customer requirements. By default, the following protocols are implemented:

- ECconf,
- MODBUS RTU
- MODBUS TCP
- MODBUS IGD

(other communication protocols are being prepared)

When using MODBUS protocols, a map of the MODBUS registers must be loaded to the device. The map assigns the numeric addresses to the measured and calculated quantities stored in the internal memory of the device. The Modbus map can be uploaded to the device by service SW [20].

The ECconf protocol is the native protocol of the device. A complete set of features implemented in the device is available. The operating SW [19] uses this protocol only; to switch to another data link layer, the ECconf protocol is just nested in another data link layer (the tunnel). Only the ECconf and CTR protocols can be used to download the firmware (protected by a metrological seal).

## 10.1 EN 62056-21 (IEC-1107) Optical Interface

In the front cover of the enclosure there is a port for communication via the optical head. The optical head is placed to the port and secured with a magnet. An HIE-04 with USB connection to the PC (or HIE 03 with RS232 interface) can be used as an optical head. When the optical head is attached, the machine switches from the standby mode into a mode that allows for data receiving. Depending on the device setting, the device remains in this state either until the attached optical head is removed from the communication interface or until the set time limit since the last communication expires (timeout within 1 to 255 seconds). The set timeout can be read and changed using the service SW [20] (parameter "Turn IR head off after [s]:" on the Service Parameters tab).

## 10.2 Modules of the Internal Modems

The device contains a build-in antenna of the integrated M2G, M4G modem. If the signal is weak at the installation site, an external antenna may be used. In this case, however, it is necessary to order a special HF cable adapter from the manufacturer to connect the external antenna. The HF cable reducer is installed as described in v Section 7.6.2.

Using the operating SW [19], the M2G modem can be set to one of the following modes:

- GSM modem
- modem GPRS modem
- GSM & SMS modem
- GPRS & SMS modem

Data transfer can be initiated either by the dispatcher station calling the device (PULL) or by the device calling the dispatcher station (PUSH).

The minimum recommended RSSI value for GPRS communication is -85 dBm (i.e. 45%). Below this value, the device displays error number 10 (see Section 6.8.3, table 13).

### Note on the SIM Card

The modem requires a SIM card in order it can be operated. The SIM card is not supplied with the device. The internal modem allows data transfer both in dial-up (CSD) mode - i.e. data transfer to GSM, and in GPRS or LTE mode. The SIM card for the given data transfer mode must be provided to the user with his mobile operator.

**For dial-up connection (CSD), the mobile operator must be required to activate the data transfer on the SIM card. Data transfer activation is, of course, required even for GPRS data transfer.**

Basic information about the modem connection and signal strength is shown on the device display with icons (see table 11). In addition, some additional information on the modem current status can be displayed. This screen can be accessed from the device keypad by selecting SYSTEM DATA-> Communication. The following information can be displayed (for details, refer to Section 6.8.3):

- The numerical code of the last error of the modem and the time of its occurrence. The numerical codes of errors and their meanings are shown in table 13.
- For the GPRS mode, the assigned current IP address
- Signal strength (in%) at the installation site

In addition, the keypad can be used, when needed, (especially for service purposes) to:

- Turn on the power of the GSM/GPRS modem,
- Initialize GSM/GPRS calls from the device to the master system (if this call option is set in the device parameters),
- Send SMS

### 10.3 Connecting communication devices via RS232 interface

In terms of data transmission, we distinguish two types of devices, DTE - Data Terminal Equipment and DCE - Data Communication Equipment.

The Prilog 400 is a DTE device.

Depending on whether a device of the same type (i.e. DTE) or a DCE-type device is used, either a crossover or a direct link cable is used. For example, a PC is a DTE device, a modem is a DCE device.

Generally (RS232):

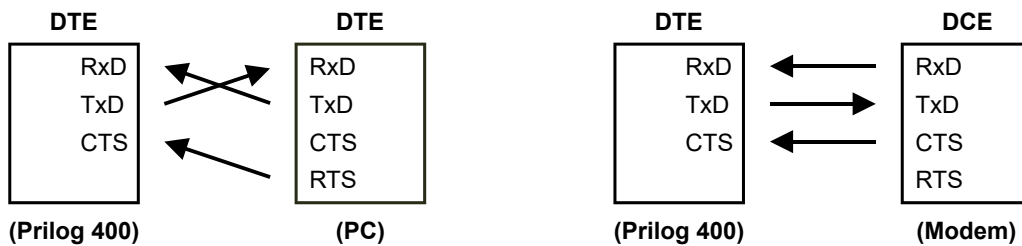

The Prilog 400 is connected via external module B-RS, B-RS/A. This communication module includes an internal signal crossing. Therefore, connecting to a PC and modem will look like this:

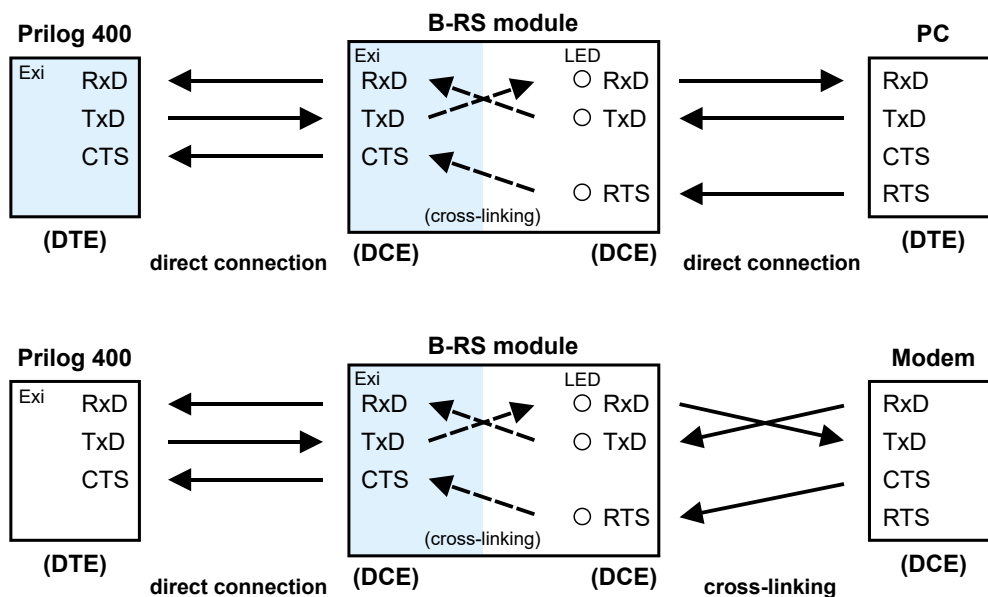

Fig. 64: Principle of connection with PC and external modem via module B-RS

### 10.3.1 Connecting an external modem

An external modem with RS232 communication interface can be connected to the device.

**For the Prilog 400 and Primus 400**, the external modem can be connected either to the S1-COM1 module, which must be located in the SLOT1 position, or to the S4-COM0 module, which must be installed in the SLOT 4 position.

Note: If S4-COM0 (SLOT 4) is used, the internal modem in SLOT 5 cannot be used.

In any case, the external modem must be connected to the device via a intrinsically safe barrier (module B-RS, or MTL5051).

If the connected modem allows it, you can use the operating SW [19] to set the parameters of the external modem communication similarly to the internal modem (see par. 10.2).

## 10.4 Encrypting Data when Communicating with the Master System

This optional feature is implemented in the ECconf and CTR protocols. For this purpose, the device contains cryptographic keys. Symmetric AES encryption with a key length of 128 bits is used. In addition, the packet of transmitted data includes the type of encryption key and the control signature. Thanks to this signature, the authenticity of the key can be confirmed, and consequently, the use of the decrypted data permitted. In case of incorrect decryption, the counterpart is informed by means of a standard error response. Modifying keys is only possible with highest security level. The keys from an unencrypted packet cannot be accepted.

The implemented protocols include the option to block the device response if an unencrypted packet has been queried. In the case of such a query, the device responds with a standard error packet.

# 11 Function Description

The device offers highly variable and user-configurable options for displaying of values and storing the quantities. The user can decide which quantities to display as actual values and which quantities should be stored in the archives.

## 11.1 Quantities Designation

The quantities are designated using the symbols shown in the table “Symbols and Terms” (see page 1).

### Quantities Designation

- The designations of the metrological quantities do not include an index.
- For other quantities (non-metrological), index can be used to distinguish the quantities of the same type.

### User Designation of Quantities

- This new feature allows the user to define customized designations of quantities. The original quantities designation then serves as the default designation (shown in blue in the service program [20]). The quantities designation must be chosen in such a way as to preserve the uniqueness of the designation. The uniqueness of the designation is checked by the operating program.
- The designation of metrological quantities can only be changed at ASC level.
- The user-defined quantities designation is used for display purposes both in the device and in the operating program and can be exported to be used in third-party software.

## 11.2 Actual Values

For the displayed quantities, the number of displayed digits, the units, and the displayed name are user-customizable. If the measured quantity is in an error state, this state is indicated by the asterisk at the last position in the quantity designation row.

Example of quantities that can be displayed as actual values:

- Pressure p1, p2
- Temperature t1, t2
- Primary volume Vm1, Vm2
- Disturbed quantity for primary volume Vs1, Vs2
- Primary flow rate Q1, Q2
- Device error
- External power supply
- Battery capacity
- Internal temperature

## 11.3 Archives

The values in the archives are ordered in time slots. Each time slot includes the time data of the slot and the values of the quantities selected for archiving.

The measured and computed quantity values can be stored in the following archives:

- Monthly archive
- Daily archive
- Data archive
- Binary archive
- Limit Archive

Besides these data archives, the device contains the following additional archives:

- Status archive
- Settings archive
- Gas composition archive

The archives with a fixed number of records (monthly, daily, binary, and limit) are stored at the beginning of the available memory of the device, and in the remaining memory, data archive is stored in (with the length depending on the size of the remaining memory).

	Data archive	Daily archive	Monthly archive	Limit archive	Binary archive
<b>Analogue values</b>					
Analogue input - mean value	yes	yes	yes		
Analogue internal - mean value	yes	yes	yes		
Analogue output - mean value	yes	yes	yes		
Minimum/maximum	yes	yes		yes <sup>2)</sup>	
<b>Quantities, flow rates</b>					
Primary volume - absolute state	yes	yes	yes		
Corrected volume - absolute state	yes	yes	yes		
Disturbed quantity for primary volume – absolute state	yes	yes	yes		
Disturbed quantity for corrected volume - absolute state	yes	yes	yes		
Max. daily consumption - primary volume			yes <sup>1)</sup>		
Max. daily consumption - corrected volume			yes <sup>1)</sup>		
Max. hourly consumption - primary volume		yes <sup>1)</sup>	yes <sup>1)</sup>		
Max. hourly consumption - corrected volume		yes <sup>1)</sup>	yes <sup>1)</sup>		
Internal counter - absolute state	yes	yes	yes		
Output pulses - pulse deficiency	yes	yes	yes		
Primary flow rate - mean value	yes	yes	yes		
Corrected flow rate - mean value	yes	yes	yes		
Minimum/maximum flow rate	yes	yes		yes <sup>2)</sup>	
<b>Binary values</b>					

Binary input - state	yes				yes
Binary output - state	yes				yes
Setpoints - state	yes				yes
Device and transducer communication errors – state	yes				yes
Binary internal	yes				yes
<b>Other values</b>					
Counter/ timer - absolute	yes				
Device status	yes	yes	yes		
<b>Notes:</b>					
1) The day or hour is stored together with the value (or in combination, where suitable)					
2) The date and time of reaching the minimum/maximum is stored together with the value					

Table 23: Quantities archiving options

### 11.3.1 Monthly Archive

The values are recorded in the archive once a month at the set "gas" hour (usually 6:00 am). The record time is stored in the archive along with the values. When the archive is filled, the new data starts to overwrite the oldest. There is an option to store statistical values for gas consumption and analogue values (see table 23).

Therefore, a record dated 01.06. means statistical values of quantities in the interval 1.05. 6:00 to 1.06. 6:00.

### 11.3.2 Daily Archive

The features are similar to the monthly archive (for the list of options see table 23). Also in this archive, the statistical values of gas consumption and analogue values can be stored. The values are recorded in the archive once a day at the scheduled "gas" hour (usually 6:00 am).

Therefore, a record dated 13.06. means statistical values of quantities in the interval 1.05. 6:00 to 1.06. 6:00.

### 11.3.3 Data Archive

#### Archiving period: adjustable from 1s to 1h

In this archive, the quantities are stored in the defined period, which can be set by the user. The default value is 1 h. For status variables, the occurrence of the active state in the archive period is stored in the archive. For binary inputs, the active status can be set according to the actual parameter setting. Log1 is the active status for setpoints and errors.

### 11.3.4 Binary Archive

The archive stores the states of binary inputs together with status bits calculated and stored in the system, and the errors of each device. The values can only be stored in this archive if the status of any stored binary is changed. The record includes a time with a resolution of seconds.

### 11.3.5 Limit Archive

For the archived quantities, limit (minimum or maximum) reaching is stored. A value and a time are stored. When this archive is initialized, the current measured values of the specific quantities are set in both maximums and minimums registers.

### 11.3.6 Status Archive

The archive stores the date and time of an event change, the status word (64 bits) describing the statuses of all the monitored events in the device and the state of the primary volume counter Vm1. The list of monitored events in the device is listed in table 14 and in table 15.

The content of the archive cannot be displayed directly, but it has to be viewed via the operating PC software.

### 11.3.7 Settings Archive

The settings archive stores the parameter changes, especially if they affect the metrological properties of the device. The ID of the person who made the change is stored in the archive, as well. The record contains the time, person ID, activity description, and new and old parameter values that have been set.

This archive is different from the other archives, as it is not rewritable, i.e. when filled, no records can be stored, and further modification of the parameters is impossible. This archive cannot be displayed directly, the contents can only be viewed on a PC.

## 11.4 Device Parametrization

### 11.4.1 SW Parameterization Using the Operating SW

The device allows for setting the parameters needed for the device to be put into operation after installation directly from the device keypad, i.e. without the need to use a computer. The description of the procedure is provided in paragraph 6.7

The device can be fully parametrized using the supplied operating SW [19] for PC. In addition to setting up the device, the software also allows reading, viewing, archiving and printing of both actual values and the archives contents. The parameterization procedure using the operating SW is described in [16].

## 11.5 Other Features of the Device

### 11.5.1 Summer/Winter Time (DST)

The time change function (summer/winter time) is implemented in the device. This function can be activated/deactivated with the operating SW. When this function is activated, the device automatically changes the time based on the region where the device is used (Europe or USA). At the same time, it is necessary to set a deviation from the central time (GMT) for correct operation. The archives of the device then distinguish whether the record was taken in summer or winter time.

## 11.5.2 Time Synchronization

The device is equipped with a time synchronization function that allows only the administrator to correct the time within a time deviation of +/- 10 minutes without recording the adjustment in the setup archive and without generating the warning message W38 in the device status.

### **Remark for CTR communication protocol:**

*If the time deviation is greater than 60 s and less than 2 hours, then the time correction is enabled, but it is recorded in the status archive. If an attempt is made to change the time by more than 2 hours, then this correction is not enabled and an alert is generated.*

In the device parameterization, if the device is equipped with a modem, it is possible to set automatic time synchronization using NTP protocol via the GPRS network or using the ETTC protocol via GSM CSD call. The time is synchronized automatically with a 20-day period, or with a 24-hour in the case of failure. If the synchronization is not successfully completed by 25th day, an E26 error is triggered and recorded in the status archive (table 14). The amount of the time deviation detected during synchronization is always evaluated with respect to the data storage frequency so that the archives are not corrupted during synchronization.

## 11.5.3 Tarif Counters

Up to four tariff counters are available in the device that allow for volume calculating according to a pre-set time schedule. There are two separate schedules (Tariff Schedule 1 and Tariff Schedule 2) that can be configured independently and only one can be active at a given time. In these schedules, the tariffs can be assigned to specific time slots in the days, and it is also possible to define whether the selected day is a working day, Saturday or Sunday (holiday).

Each schedule has its own identification number and the time of activation can be set separately for each schedule.

## 11.6 Protection against change of Metrological Parameters

The device is protected against unauthorized manipulation (especially with data that affect the metrological characteristics of the device) with a metrological and service switch and uses password system security. Changes to the device settings and other operations are stored in the settings archive. These measures make it possible to protect the device both in accordance with and beyond standard EN 12405-1.

### 11.6.1 Protection Switches

The device contains two switches, a metrological switch and a service switch.

#### 11.6.1.1 Metrological Switch

- Protects the metrological setting of the device. It is located on the inside of the enclosure cover (see fig. 46) and is protected by plate secured with the metrological seal.

#### 11.6.1.2 Service Switch

- The service switch is located beneath the metrological switch (fig. 46). Opening the device and the switch accessibility can be protected with the user mark, see fig. 2.

The **service switch** function depends on the settings in the device parameters. The settings are

done via the operating program (Parameters Menu -> Service Switch Function). Here, the user can choose what effect the switch settings will have on each device parameter group.

This variability resolves the setting of various access options to work with the device (e.g. remote setting of the parameters via the modem ...).

Using the operating SW, the user can select one of the following functions for the service switch:

120

Switch function	Position	Description
<b>Full</b> <sup>12)</sup>	OFF	Writing parameters into the device is blocked.
	ON	Parameters can be entered into the device.
<b>Non</b>	OFF	The position of the switch is of no significance, writing to the device is possible. The switch protection has been overridden.
	ON	
<b>Partial</b>	OFF	Writing to the device is blocked with the exception of non-metrological parameters (such as archiving frequency, system time etc.) This setting is suitable for remote data transfers from the device. Protecting the setting with a password is recommended.
	ON	Parameters can be entered in the device (in the same way as in the case of full function).

Table 24: Service Switch Settings

## 11.6.2 Passwords

The device has password protection implemented. The use of passwords may be restricted depending on the communication protocol set. Maximum number of passwords that can be entered in the device is 50. When the password protection in the device is turned on (see below), the passwords must be used both for serial line or modem communication and for setting device parameters using the device keypad. When setting parameters from the keypad, the list of items to be edited is limited by the access level permitted.

### 11.6.2.1 Password Groups (Valid for ECconf, MODBUS, and CTR)

The passwords are divided into 5 groups. Users of the "Administrators" group have the highest rights, the users of the "User 3" group have the lowest rights. Higher-level users have lower-level users rights, plus some others. Up to 10 passwords can be used in each group (i.e., a total of 50 passwords are available). The passwords are identified by a three-digit numeric designation. The length of each password is limited to a maximum of 6 characters. Users in all the groups can change their own passwords. The group administrator (the user with the highest ID in each group) can change the passwords of other users in that group. The administrator of the "Administrators" (ID = 801) group can change the passwords of the administrators of the other groups. According to the communication protocol used, the following characters can be used in a password:

<sup>12)</sup> This function has been pre-set by the manufacturer (default setting).

Communication Protocol	Permitted characters	Note
ECconf	letters a-z, A-Z, digits 0 to 9	password length 1 to 6 characters case-sensitive
CTR	digits 0 to 9 (the device allows for entering letters, which however are rejected by the counterpart station)	password length must be 6 characters (the device allows for entering shorter password, which however is rejected by the counterpart station)
MODBUS	digits 0 to 9	password length 1 to 6 characters

Table 25: Password format

**Note**

**Turning on password protection**

- by entering a password with ID 801 (default: 1234).

**Turning password protection off**

- by deleting the password with ID 801.  
By deleting the ID 801 password, the other passwords set in each group are deactivated, but their settings are not lost. Once the password protection is enabled, they become active again.

With selection of the menu item „DEVICE CONFIG“ the input field for the password opens. The input is made as described in chapter 6, the cursor ↑ shows the input position. This field can also appear elsewhere.

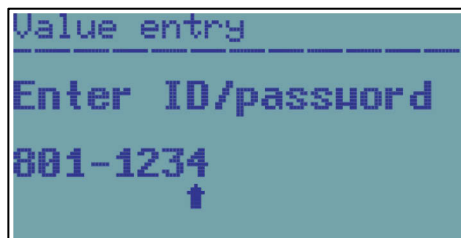

Fig. 65: Entering password

Password Group	Password IDs	Description
<b>Administrators</b>	801 to 810	<p>When the metrology switch is set to ON, the metrological properties of the device can be changed:</p> <ul style="list-style-type: none"> <li>• Loading a new firmware using the "Loader"</li> <li>• Loading new MSP processor firmware</li> <li>• Resetting metrological archives (settings archive, status archive, gas composition archive)</li> <li>• Transducer replacement, calibration of the data logger</li> <li>• Creating or removing metrological quantities</li> <li>• Changing the name or prefix of metrological quantities</li> <li>• Changing the device status</li> <li>• Changing a restriction</li> <li>• Setting the schedule of the tariff currently active</li> </ul> <p>When the metrology switch is set to ON, it is possible to:</p> <ul style="list-style-type: none"> <li>• Load a new firmware using the "Remote Download"</li> <li>• Setting the system time of the device if the device is used with CTR protocol (in other cases, the settings can be made for lower-level users)</li> </ul>
<b>Service Maintenance</b>	811 to 820	Switching to the "Maintenance" mode and back to "Normal"
<b>User 1</b>	821 to 830	<p>Depending on the service switch, the parameters are divided into groups. For the effect of the service switch, see table 24.</p> <p>Parameters influencing metrological properties:</p> <ul style="list-style-type: none"> <li>• DST mode setting (summer / winter time)</li> <li>• Unit and constants of the quantity, configuration of the pulse input of metrological variables</li> <li>• Assigning the influence of the service switch to parameter entering</li> </ul> <p>Other parameters:</p> <ul style="list-style-type: none"> <li>• Adding to or reducing non-metrological quantities</li> <li>• Setting the parameters of non-metrological quantities - name, marking, unit, constants</li> <li>• Saving to the appropriate data archive</li> <li>• • setting the input quantity connection with the output in the form of the user equation</li> <li>• Setting the communication parameters</li> <li>• Setting the descriptive data - station name</li> <li>• Setting the measurement frequency and the archiving frequency</li> </ul>
<b>User 2</b>	831 to 840	<p>permits:</p> <ul style="list-style-type: none"> <li>• Setting the system time (when using CTR, this setting is only possible for the "Administrators" group)</li> </ul>
<b>User 3</b>	841 to 850	<ul style="list-style-type: none"> <li>• Permits reading data from the device</li> <li>• (does not permit writing to the device)</li> <li>• Setting the access password</li> </ul>

Table 26: Password Groups and their Specification

**Notes:**

Administrator with password identifier 801 is authorized to:

- Set passwords for the other administrators (ID 801 to 810)
- Set passwords with IDs 811, 821, 831 and 841

The first user in each group (ID 801, 811, 821, 831 and 841) is allowed to assign passwords to other users in the same group.

**11.6.3 Levels of Access**

From the point of view of modifying parameters and other operations with the device, it is possible to divide the users of devices according to different levels of access.

**User Level**

- Common user of the device. At this level, reading all the data from the device and setting a large number of parameters is allowed. It is not possible to change the parameters directly affecting the metrological properties of the device. For more details, see table 27. As a protection against misuse, protection switch together with user mark and password system can be used.

**Accredited Service Centre (ASC)**

- Designed for the workers of the centre authorized by the manufacturer. The Centre is authorized to carry out operations relating to the device metrological properties. These activities require the breaking the metrological seal, switching the metrological switch and using a **special HW key** for the operating program [19]. For the description, see table 28

User Level			
	Activities	Service switch	Activities permitted with password protection
Reading data	<ul style="list-style-type: none"> <li>• Reading actual values of quantities</li> <li>• Reading archives</li> <li>• Reading parameters</li> </ul>	OFF, ON	<ul style="list-style-type: none"> <li>• Permitted with password protection off</li> </ul>
Non-metrological parameters changes	<ul style="list-style-type: none"> <li>• Turning archiving of the quantities into the archives on / off</li> <li>• Setting the measurement frequency</li> <li>• Setting archiving frequency of data archive</li> <li>• Changing passwords</li> <li>• Resetting archives</li> <li>• Setting the internal time of the data logger</li> <li>• Setting communication parameters</li> <li>• Setting station identification</li> <li>• Setting the start time of the gas day</li> <li>• Switching displaying the actual values of non-metrological variables on / off</li> </ul>	ON	<ul style="list-style-type: none"> <li>• Permitted with password protection off</li> </ul>

	<ul style="list-style-type: none"> <li>Configuring digital inputs</li> <li>Configuring digital outputs</li> <li>User designation of the quantities</li> </ul>		
<b>Metrological changes</b>	<ul style="list-style-type: none"> <li>Assigning the influence of the service switch on parameter writing</li> <li>Setting the V and Vs counters</li> <li>Setting units and constants</li> <li>Setting of temperature and pressure substitute values for conversion</li> </ul>	ON	

Table 27: User access level - for the "full" function of the service switch

<b>Authorized Service Centre (ASC) Level</b>			
<b>Activities</b>		<b>Service switch</b>	<b>Activities permitted with password protection</b>
	<ul style="list-style-type: none"> <li>All the activities described in the user level</li> <li>Setting the status bit mask (Diagnostics quantity)</li> </ul>	OFF, ON	Note: When using the HW key, the effect of passwords is suppressed, if used with the device.
<b>Metrological changes</b>	<ul style="list-style-type: none"> <li>Firmware upgrade</li> <li>Changing metrological approval variant (NMI, CMI, ...)</li> <li>Configuring metrological quantities (V, Vs)</li> <li>Replacing the transducers</li> <li>One-point or two-point transducer assembly</li> <li>Reset the archive settings and status archive</li> <li>User designation of the quantities</li> </ul>	ON	Using the HW key designated WGQOI, "Accredited Service" version

Table 28: ASC Access Level

# 12 Accessories

## 12.1 Plug-in Modules for Prilog 400 data logger

Module	Designation	Slot
S0-SCR	Interface for SCR gas meter encoder	SLOT 0
S0-NAM	Interface for NAMUR gas meter encoder	
S0-EXT1	Extension module - 2 HF NAMUR pulse inputs, 6 digital inputs, 2 passive analogue inputs, 2 transducer connection <sup>13)</sup>	
S1-COM	RS232/RS485 communication module	SLOT 1, SLOT 2
S1-2AI	4-20 mA analogue inputs module (2 passive inputs)	
S1-2AO	4-20 mA analogue outputs module 4-20 mA (2 outputs)	
S3-PWR1	EVC external power supply module	SLOT 3
S4-PWR2	Module of external power supply of internal module	SLOT 4
S4-COM0	RS232 communication module	
M2G	Internal modem 2G	SLOT 5 <sup>14)</sup>
M4G, LTE-Cat1E	Internal modem LTE cat.1-E	
M4G, LTE-Cat1US	Internal modem LTE cat.1-US	
M4G, LTE-CatM1	Internal modem LTE cat.M1-US	

### Extension Internal Module

BARP	Module for barometric pressure measurement (must be specified in the order, cannot be installed by user)
------	---

<sup>13)</sup> External power supply from S3-PWR1 is required

<sup>14)</sup> If external power supply to the modem is not used, the internal modem module is mounted in SLOT 4 instead of in slot SLOT 5

## 12.2 External Modules

The main function of these modules is to ensure external power supply of the device and external power supply of internal modems and to ensure correct connection of other cooperating devices, which extend the utility features of the device. Since the device is intrinsically safe, the following modules act as a safety barrier (except for the CLO module) to connect conventional devices.

126

### Dual module design

Most of the modules are available in two versions - the basic version and the designation "/A" (e.g. PS-E and PS-E / A). Both designs are functionally identical, the difference is only in its resistance in terms of intrinsic safety, current consumption and the possibility of galvanic separation.

**basic design** - for common use, the module is powered with a 12V power supply connected to the 230Vac power supply (intrinsically safe parameter  $U_m = 250V$ ). The intrinsically safe module terminals are galvanically isolated from the other terminals.

**"/ A" version** - the module has reduced its own current consumption, therefore it is suitable for installations where the 230Vac power supply is not available and which are powered from the battery (intrinsically safe parameter  $U_m = 60V$ ). In this case, the power supply battery must not be charged from a power supply connected to the 230Vac power supply. The module does not have galvanic isolation of terminals.

The external modules are designed for DIN rail mounting into the switchboard. There are separate manuals for the modules. The use of external modules is illustrated in fig. 66 and fig. 67.

### 12.2.1 Intrinsically Safe Sources for External Power Supply

PS-E PS-E/A	External intrinsically safe power supply for the data logger (powered from 12Vdc mains)	*)
PS-M PS-M/A	External intrinsically safe power supply for internal 2G or 4G modem (powered from 12Vdc mains)	*)

\*) *under preparation*

### 12.2.2 Separation and Communication Modules

B-RS B-RS/A	Separation barrier for RS485	*)
B-DI	Separation barrier for digital inputs (2 pcs)	*)
B-DO B-DO/A	Separation barrier for digital outputs (4 pcs)	*)
B-IB	Separation barrier for internal bus	*)

\*) *under preparation*

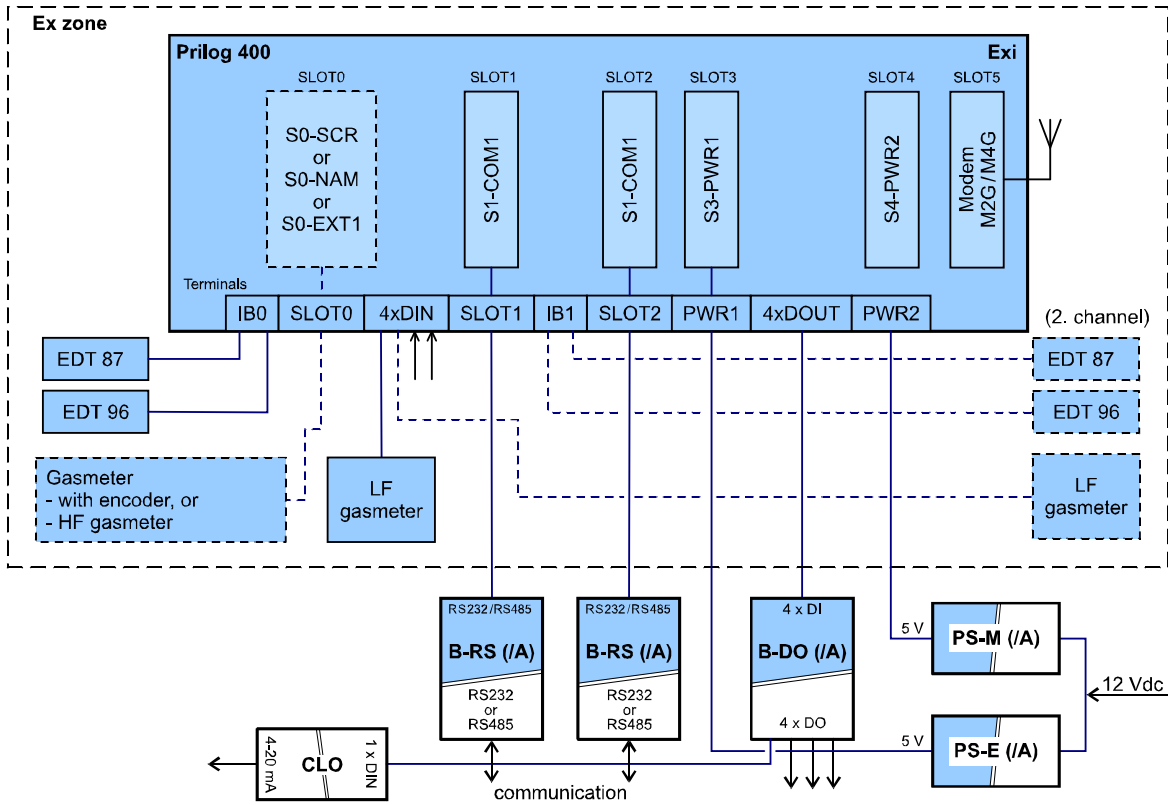
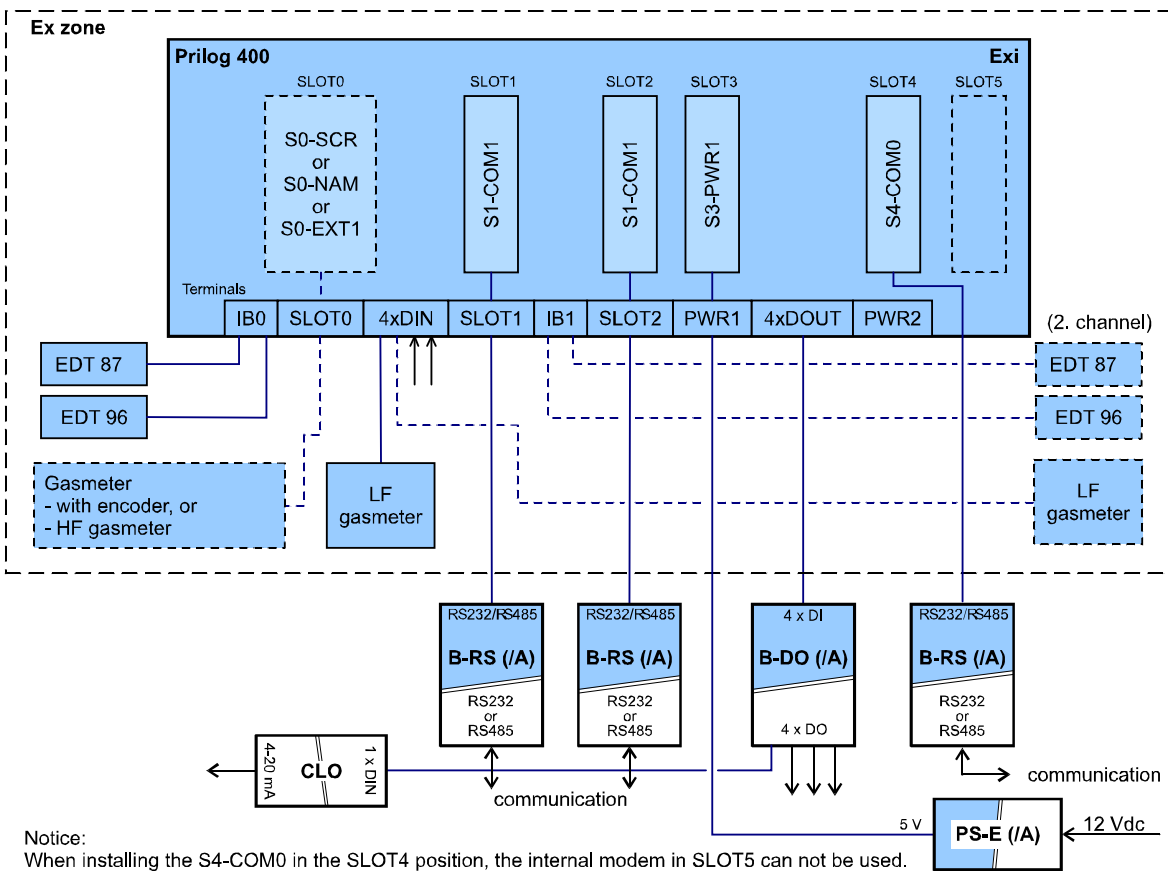

Fig. 66: Prilog 400, example 1 of use of external modules



Notice:

When installing the S4-COM0 in the SLOT4 position, the internal modem in SLOT5 can not be used.

Fig. 67: Prilog 400, example 2 of use of external modules

## 12.3 Other Accessories

CLO	4-20 mA analogue output module	*)
HIE-04 B	IR head with USB communication interface (max. 115 200 Bd)	
HIE-04	IR head with USB communication interface (max. 38 400 Bd) (production ceased)	
HIE-03	IR head with RS232 communication interface (max. 38400 Bd) (production ceased)	
EDT 87	Temperature transducer	
EDT 96	Pressure transducer, internal or external	

## 12.4 Order numbers for spare parts and accessories

Order number	Description
--------------	-------------

### Mechanical components

30.00.584.00	Wall mounting plate
30.00.585.00	Kit for pipe mounting DN 50
30.00.586.00	Kit for pipe mounting DN 100
30.00.587.00	Kit for pipe mounting DN 150
00.67.105.00	Adapter plate for EK280

### Electronical components

38.01.100.00	Communication module RS232/485 (S1-COM)
38.01.100.01	Analog input module (S1-AI)
38.01.100.02	Analog output module (S1-AO)
38.01.100.03	Power module EVC (S3-PWR1)
38.01.100.04	Power module Modem (S4-PWR2)
30.00.579.00	Barrier for Communication module RS232/485 (B-RS)
30.00.580.00	Barrier for Digital Output (B-DO)
38.01.100.05	Analog output 4-20 mA
30.00.581.00	Barrier for Power module EVC (S3-PWR1)
30.00.582.00	Barrier for Power module Modem (S4-PWR2)
38.01.100.06	GSM/GPRS modem
38.01.100.07	4G/LTE modem
38.01.100.08	Battery GSM/ GPRS Modem (HB-03D)

38.01.100.09	Battery LTE Modem (HB-04)
38.01.100.10	Battery EVC (B-03D)
86.77.554.04	Infra-red head (HIE-04B)
38.01.100.11	Pressure sensor 1:5 (EDT-96)
38.01.100.12	Temp. Sensor (EDT-87)
30.00.583.00	2G Modem antenna
30.00.583.01	LTE Modem antenna
30.00.703.00	Cable adapter external antenna
30.00.712.00	Analog output module Zone 2 (S1N-2AO)
30.00.713.00	Analog input module Zone 2 (S1N-2AI)
30.00.714.00	RS232/485 interface Zone 2 (S1N-COM1)
30.00.715.00	230V Power supply Zone 2 (PWR3)
30.00.716.00	24V Power supply Zone 2 (PWR4)
30.00.698.00	Klax 2.0 Prilog 400
40.00.041.00	HF/ENCO module (S0-EXT1)
40.00.061.00	Potential-free output (Turck IM1-12-T)
86.98.249.01	Barrier + supply AO (KFD2-STC5-Ex1)

# Appendix

## A System Menu

Data that can be displayed on the device display are structured based on the menu. For the purposes of further interpretation, we call the basic menu items the highest items. By entering those items, navigate to the lower menu levels (submenus).

### A.1 Main Menu

The menu depends on the parameters set in the device. The set of items below can be changed according to the device settings.

The main menu consists of eight items. The main menu can be displayed from the home screen by pressing the (ENTER) key. You can scroll through one of the keys (LEFT, RIGHT). If any of the main menu items contains a submenu (e.g. PARAM, CONFIG or SYSTEM), the submenu is entered by the ENTER key.

	main menu	1st submenu	2nd submenu	3rd submenu	Note
1	<b>Vm</b>				actual value of the volume counter at measurement conditions
2	<b>ACTUAL</b>				actual values display
		Vm			actual value of the primary volume counter at basic conditions
		P			actual value of gas pressure
		T			actual value of gas temperature
		Q			actual value of primary flow rate
		Vs			actual value of the disturbed quantity at measurement conditions
		... etc.			other items depending on the device configuration
3	<b>MENU1</b>				user-defined display of actual values
4	<i>(reserve)</i>				<i>Reserved</i>
5	<b>PARAM</b>				displaying the device parameters
		COMMUN			communication address
			COM.GEN.		General
				ADR1	communication address 1
				ADR2	communication address 2
			IR.HEAD		optical head
				SPEED	baud rate
				PROT.	communication protocol
			COM0		communication device connected via SLOT 4,5

				SPEED	baud rate
				PROT.	communication protocol
				COM.DEV.	communication device
			COM1		communication device connected via SLOT1
				SPEED	baud rate
				PROT.	communication protocol
				COM.DEV.	communication device
			COM2		communication device connected via SLOT2
				SPEED	baud rate
				PROT.	communication protocol
				COM.DEV.	communication device
		SERV			service parameters
			S.N.DEV		device serial number
			VER.APP		application SW, version no., CRC
			VER.MTR		metrological firmware, version no., CRC
			VER.LDR		loader – version no., CRC
			ST.NAME		Station Identification
		INPUTS			input parameters
			Vm		primary volume
				GAS KP	gas meter constant [imp/m <sup>3</sup> ]
				S.N.GAS	gas meter serial number
			P		pressure measurement
				P.RANGE	pressure range
				S.N. P	serial number of the transducer
			T		temperature measurement
				T.RANGE	temperature range
				S.N. T	serial number of the transducer
<b>6</b>	<b>CONFIG</b>				setting the device parameters from the keyboard
		SERV			setting service parameters
			ST.NAME		Station Identification
			GAS.H		hour of the start of the gas day
		COMMUN			setting communication parameters
			COM.GEN.		general parameters
				ADR1	communication address 1
				ADR2	communication address 2

			IR.HEAD		optical head
				SPEED	baud rate
				PROT.	communication protocol
			INT.MOD		communication device
				SPEED	baud rate
				PROT.	communication protocol
			COM1		RS232/RS485 interface
				SPEED	baud rate
				PROT.	communication protocol
			COM2		RS232/RS485 interface
				SPEED	baud rate
				PROT.	communication protocol
		DAT:TIM			
			TIME		system time of the device setting
			DATE		the date setting
		VOL1			volume setting
			GAS KP		the gas meter constant setting
			Vm		primary volume setting
			Vs		primary volume disturbed quantity setting
			S.N.GAS		gas meter serial number setting
			QMAX		maximum gas meter flow rate setting
		CLEAR.A			deleting archives contents
			DATA.AR.		deleting the data archive
			DAY.AR.		deleting the daily archive
			MONTH.A.		deleting the monthly archive
			TARIFF		deleting the tariff archive
			BINARY		deleting the binary archive
			LIMIT.A.		deleting the boundary archive
			SETUP.A.		deleting the settings archive
			STATUS		delete the status archive
			GAS.AR.		deleting the gas composition archive
		WORK.M.			working regime setting
		SAVE.PA			entering the set parameters into the device
<b>7</b>	<b>SYSTEM</b>				system parameters display
		TIME			system time display
		DATE			system date display
		RESET			device reset
		MODEM			modem parameters

			MODEM1	modem no.1 parameters
			GPRS.IP	up-to-date GPRS modem IP address
			MODERR	last modem error code and time of occurrence (Err.xx format hh: mm DD.MM.YY) "Xx" - modem error code (see table 13)
			SIGNAL	Measuring the signal strength triggered by a keyboard command. Showing measurement status: BTS: test BTS: roam BTS: connect BTS: search BTS: no BTS: denied  After the signal strength is successfully measured, the value in percent (SIG: xx [%]), converted to dBm - see table 12) is displayed. Automatic shutdown after 2 min or by shutdown by the user.
			MOD ON	Turning the modem power supply on manually from the keypad - switches on, or switches on and connects to GPRS according to the set mode - the time in seconds to automatic exit and shut down the of modem is displayed - automatic shutdown after 5 minutes or shutdown by the user
			CALL	Manual initialization of GSM / GPRS calling from the device to the master system - must be enabled in parameters - after activating the command, it displays "Working" - then you can exit the mode and the device performs the action
			PACKET	displays the number of packets sent during the active or last communication
		BAT.EVC		remaining battery capacity [%]
		Vcc		battery voltage
		LATCH		Displays and freezes the actual values on the display. This function is used to check the field operation of the device (abbreviated test). For E, Es, the decimal part of the value is displayed when Enter is pressed.
<b>8</b>	<b>DIAG</b>			Device Diagnostics
		ACT.ST.		The current device status is displayed (browse by pressing ENTER)

		SUM.ST.			The device checksum is displayed (browse by pressing ENTER)
		SUM.CLR			resetting total status
		TEST			triggering the device test
<b>9</b>	<b>TARIFF</b>				
		ID.CURR			
		ID.PREV			
		PREV.D			

**Note:**

The number of display characters (digits) on the display at a time is limited to 10. If you need to display longer information (such as ST.NAME - Station Identification), the displayed information will be scrolled.

**A.1.1 ACTUAL Menu – Actual Values Display**

*(serial number 2 of the main menu)*

Immediate values of metrological quantities and the set non-metrological quantities are displayed (the non-metrological quantities are set in the parameters of the instrument using the operating program [19]). In the basic view (device idle), these data are displayed periodically on the display (except as in A.1.2).

**Indication of Exceeding the Limit**

If the value of the measured quantity is outside the measuring range of the instrument, the "E" flag appears before the displayed numeral.

**A.1.2 USER 1, USER 2 Menu**

*(serial number 3 and 4 of the main menu)*

These items are displayed only if they are set in the device. Settings can only be performed by the service SW [20].

With these settings, actual values can be displayed, in the order defined by the user.

**Note**

**If the USER 1 menu is set in the device, the display of the actual values defined in the ACTUAL menu item is suppressed in the device and the actual values defined in the USER 1 item are displayed.**

**A.1.3 PARAM Menu**

*(serial number 5 of the main menu)*

Select this menu to display the set parameters of the device.

#### A.1.4 CONFIG Menu

*(serial number 6 of the main menu)*

Use this menu to set the device parameters from the keypad. Service parameters, communication parameters, gas composition, system date and time, gas meter parameters and volume measurement parameters can be set. After changing the parameters, you must save the changed values to the device memory using the last submenu option SAVE.PA.

Select CLEAR.A to delete the contents of the device archives.

#### A.1.5 SYSTEM Menu - system data

*(serial number 7 of the main menu)*

##### RESET - Device Reset

After selecting the device reset, the program jumps to the initial address and re-initializes the entire measurement system. The contents of all the archives and the states of all gas volume counters ( $V_m$ ,  $V_s$ ) do not change during this operation, nor any other configured parameters. Execution of the command is independent of the position of the service switch.

##### MODEM

In this option you can find the assigned IP address of the device for the configured GPRS modem and the mobile signal strength of the device at the device location. In addition, you can turn on the modem and, if necessary, initiate connection with the dispatch centre if the device is configured to send alarms. These operations are especially useful when configuring the modem and putting the device into operation.

##### LATCH - Freezing the Actual Values

The actual values measured are frozen at the display on pressing the key. The frozen values of the quantities ( $V_m$ ,  $p$ ,  $T$  etc.) can be displayed in the standard way when displaying the actual values. Press ESC to stop displaying frozen quantities.

The LATCH function should be used, for example, when manually copying the values of the measured actual values when checking the accuracy of the device.

#### A.1.6 DIAG Menu Item - the Device Diagnostics

*(serial number 8 of the main menu)*

V menu DIAG Information on the device condition are stored in the DIAG menu.

##### ACT.ST. - Actual Status

This menu displays the actual state of the device. Pressing the RIGHT key shows all the current errors and warnings of the device one after another.

##### SUM.ST. - Checksum

The checksum is used to monitor the occurrence of active error states (individual device status bits) since the last checksum initialization. This means that also statuses of the device that may have been already extinct are stored in the memory.

The error status information is also displayed as a "bell" icon on the device display.

## SUM.CLR. - Checksum Trigger

On selecting this option on the device keypad or via the "Clear Checksum" option from the "Setup-Diagnostics" menu from the operating SW on the PC, the checksum is triggered, i.e. the current status is set according to the actual status. To enable the triggering, the service switch must be ON. If it is switched to OFF, a message ("Not Possible") is displayed, warning that the function cannot be triggered.

136

## TEST - Device Test

After selecting this menu item, the device tests its internal state and displays a list of detected errors and warnings. The test runs for several seconds (the message "Working" appears on the display) and does not affect the actual measuring and archiving operation of the device. The command execution is independent of the position of the service switch.

During the test, WARNING is displayed on the display. The indicated errors are identified with the prefix "E" and the identification number; similarly, the prefix "W" is used for the warnings <sup>15)</sup>. Refer to table 14 and table 15 for a complete list of error messages and warnings.

---

<sup>15)</sup> Due to the limitation of character display on the customer display, the "W" is displayed as "U"

## B Prilog 400 Version for Zone 2

### B.1 Introduction

This appendix describes a version of the Prilog 400 that has a different type of explosion protection than the one described in the previous section of the manual and is intended for use in a hazardous area Zone 2.

#### Note

##### Modification of the ATEX marking

With the introduction of Revision 3 of the EU type examination certificate (ATEX) No. **FTZÚ 19 ATEX 0121X** on 18 April 2023, the ATEX marking for **Prilog 400 devices for Zone 2** was also amended. The previous part of the designation, 'nA', has been replaced by 'ec'.

Previous marking:  $\text{Ex}$  II 3G Ex ic nA IIB T4 Gc

Marking from 18.04.2023:  $\text{Ex}$  II 3G Ex ic ec IIB T4 Gc

The following descriptions include the currently valid part designation 'ec'.

In the following, this embodiment of the device is designated Prilog 400 for Zone 2.

Prilog 400 for Zone 2 is implemented with "ec" type protection in combination with "ic" protection and cannot be used in Zone 0/1 environments.

This version of the device can be also supplied under the trade name Primus 400 for Zone 2 as an electronic volume corrector.

The appendix describes the differences between the Prilog 400 for Zone 2 and the intrinsically safe version of the device described in the main body of this document.

#### ⚠ Caution

The Prilog 400 for Zone 2 with explosion-proof category "II 3 G" and combined explosion protection "ic ec" must not be used in Zone 0/1 environments, otherwise, there is a risk of explosion.

The whole device with transducers and etc. must be located in the Zone 2 environment (i.e. including pressure and temperature transducers).

The production label with ATEX is located on the top of the housing.

#### Note

The device Prilog 400 for Zone 2 has a working temperature limited to range of:

Operating temperature scope:  $-25^{\circ}\text{C} - +60^{\circ}\text{C}$

## B.2 Safety

### B.2.1 General

The device **Prilog 400 for Zone 2** is approved according to Directive 2014/34/EU and has been released with the following certificate:

<b>FTZÚ 19 ATEX 0121X</b>	EU type-examination certificate (ATEX) for use in potentially explosive atmospheres.
---------------------------	--

#### Important Notice:

#### **Caution**

The device is designed according to safety principles for use in potentially explosive atmospheres of type Zone 2.

It is approved as a safe device with combined protection of the type “intrinsic safety” ic and a type of non-sparking device “ec” according to the standards EN 60079-0, EN 60079-11 and EN 60079-15.

The version for Zone 2 must not be used in Zone 0/1, otherwise, there is a risk of explosion.

#### **Danger**

The device must be installed and used in accordance with this documentation and the conditions specified in the ATEX certificate.

#### **Warning**

The specified protection IP66 is only valid if cables of suitable diameter and proper tightening are used in the cable glands of the device. Unused cable glands must be blinded.

### B.2.2 Use in potentially explosive atmospheres zones

Based on EU certificate of Examination type 19 ATEX 0121X, the device can be operated in a potentially explosive atmosphere designated Zone 2 (area in which an explosive gaseous atmosphere is not likely to occur during normal operation, but will remain for a short period of time if this atmosphere occurs – EN 60079-10-1).

**Prilog 400**

Designation of explosion safety	Device and its internal equipment	Environment
II 3G Ex ic ec IIB T4 Gc	<p><b>- basic design including module extensions:</b></p> <p>S0-NAM Interface for NAMUR gas meter encoder,                      S0-SCR Interface for SCR gas meter encoder,                      S0-EXT1 Expansion module,                      S1N-COM1 RS232/RS485 communication module,                      S1N-2AI Analogue inputs module,                      S1N-2AO Analogue outputs module,                      S4N-PWR3 Module of data logger and modem external power supply,                      S4N-PWR4/24V Module of data logger and modem external power supply,                      M2G Internal modem 2G,                      M4G Internal modem LTE-Cat1 or Internal modem LTE-Cat M1</p>	<b>ZONE 2</b>

**⚠ Caution**

**If the ATEX marking is marked with the category “II 3 G”, the device must not be operated in Zone 0/1, but only in Zone 2!**

**The ATEX label is located on the top of the housing.**

When connecting the device, it is to be expected with the electrical properties of connecting cables and comply with the requirements of the relevant safety standards. Furthermore, it is necessary to respect the Special Conditions of Use, if mentioned in these certificates.

**B.2.3 Special conditions of use**

**⚠ Caution**

**In certain extreme situations, an electrostatic charge capable of initiation may be formed on the plastic housing. The device must not be installed in places where external conditions could lead to electrostatic charging. The device may only be wiped with a damp cloth.**

**⚠ Caution**

**Do not open the device if there is an explosive atmosphere!**

### B.2.4 Risks of Use

The housing is made of polycarbonate. On the top lid is placed foil keyboard made of polyester. In some extreme cases, electrostatic charges may build up on the cabinet surface. Its energy could cause the initial explosive atmosphere to initialize.

Here are recommendations to avoid the risk of ignition due to electrostatic charges:

- **If the device is used in a potentially explosive atmosphere, it must not be installed in a place where external conditions may cause electrostatic charges.**
- **The device may only be cleaned with a damp cloth. It is also necessary to observe:**
  - **the cables must be tightly tightened in the cable glands against pulling out**
  - **the device must not be opened if there is an explosive atmosphere**
  - **the enclosure must not be damaged**

### B.2.5 Connecting of external devices

#### **Caution**

**In terms of safety, the device is equipped with connection terminals with two types of signals:**

- **terminals with intrinsically safe signals**
- **terminals with signals with protection “ec”**

**The terminals of intrinsically safe device can be connected only approved devices (intrinsically safe device associated apparatus) or so. Simple devices complying with the standard EN 60079-11 and complying with the intrinsically safe parameters mentioned in paragraph in the EU Examination Certificate Type[16].**

**Terminals with “ec” protected signals can be connected to standard equipment that meets operating parameters. When connecting wires to these terminals, it must be non-energized conductor.**

**The relevant safety standards must be observed when wiring.**

**The electrical connection** of external devices to the Prilog 400 for Zone 2 is described in paragraph 8 of this Annex.

**The designation of intrinsically safe and “ec” terminals** is described in paragraph 8.1 of this Annex.

The connection of the device must be carried out in accordance with the applicable norms and standards, in particular:

EN 60079-0 - Electrical apparatus for explosive gas atmospheres - Part 0: General requirements,

EN 60079-11 - Explosive atmospheres - Part 11: Protection of equipment by intrinsic safety “i”,

EN 60079-14 - Explosive atmospheres - Part 14: Design, selection and installation of electrical installations,

EN 60079-15 - Explosive atmospheres - Part 15: Equipment protected by type of protection “n”

EN 60079-25 - Explosive atmospheres - Part 25: Intrinsically safe electrical systems,

**B.3 Safety parameters of signals on terminals**

**B.3.1 Intrinsically safe terminals**

**Digital inputs DIN:** (terminals DI1, GND, DI2, GND, DI3, GND, DI4, GND)

U<sub>o</sub> = 6.5 V    U<sub>i</sub> = 5.5 V    C<sub>i</sub> = 0  
 I<sub>o</sub> = 2 mA    I<sub>i</sub> = 1 mA    L<sub>i</sub> = 0  
 P<sub>o</sub> = 3 mW    P<sub>i</sub> = 1 mW

	IIB	IIA
Co	20 μF	100 μF
Lo	10 mH	100 mH

**Internal bus IB0 and IB1:** (terminals GND, U+, D-, D+)

U<sub>o</sub> = 6.5 V  
 I<sub>o</sub> = 2.2 A  
 P<sub>o</sub> = 1.1 W

	IIB	IIA
ΣCo	24 μF	50 μF
ΣLo <sup>4/</sup>	1 μH	1 μH

<sup>4/</sup> concentrated inductance, max. 100 m cable can be connected

**SCR interface - KP 100 061:** (terminals SLOTO TERMINALS: A, B)

U<sub>o</sub> = 8.0 V  
 I<sub>o</sub> = 20 mA  
 P<sub>o</sub> = 160 mW

	IIB	IIA
Co	14 uF	100 uF
Lo <sup>4/</sup>	8 μH	10 μH

<sup>4/</sup> concentrated inductance, max. 30 m cable can be connected

**NAMUR interface - KP 100 062:** (terminals SLOTO TERMINALS: NAMUR+, NAMUR-)

U<sub>o</sub> = 10.0 V    U<sub>i</sub> = 5.5 V    C<sub>i</sub> = 0  
 I<sub>o</sub> = 11 mA    I<sub>i</sub> = 1 mA    L<sub>i</sub> = 0  
 P<sub>o</sub> = 27 mW    P<sub>i</sub> = 1 mW

	IIB	IIA
Co	20 μF	100 μF
Lo	1 mH	1 mH

**Module EXT1 (KP 100 130) – DI1, DI2 (NAMUR):** (terminals SLOT0 TERMINALS: DI1-, DI1+, DI2-, DI2+)

$U_o = 10.0 \text{ V}$

$I_o = 11 \text{ mA}$

$P_o = 27 \text{ mW}$

	IIB	IIA
Co	20 $\mu\text{F}$	100 $\mu\text{F}$
Lo	1 mH	1 mH

**Module EXT1 (KP 100 130) – DI3 to DI8:** (terminals EXT1-T: GND, DI3, DI4, DI5, DI6, DI7, DI8)

$U_o = 6.5 \text{ V}$

$I_o = 2 \text{ mA}$

$P_o = 3 \text{ mW}$

	IIB	IIA
Co	20 $\mu\text{F}$	100 $\mu\text{F}$
Lo	10 mH	100 mH

**Module EXT1 (KP 100 130) – analog inputs AIN:** (terminals EXT1-T: GND, AI1, GND, AI)

$U_i = 28 \text{ V}$

$I_i = 93 \text{ mA}$

$P_i = 0.66 \text{ W}$

$C_i = 40 \text{ nF}$

$L_i = 0$

### B.3.2 Terminals with protections “ec”

**Digital outputs DOUT:** (terminals U0+, GND0, DO1, DO2, DO3, DO4)

$U_n = 28\text{V}, \quad I_n = 100 \text{ mA}$

**RS485 interface - KP 100 110:** (terminals SLOT1,2 TERMINALS: D+, D-, GND, U+)

$U_n = 28 \text{ V}$

**RS232 interface - KP 100 110:** (terminals SLOT1,2 TERMINALS: GND, CTS, RXD, TXD)

RXD:  $U_n = \pm 15 \text{ V}, \quad \text{CTS: } U_n = \pm 28 \text{ V}$

**Analog inputs AIN - KP 100 112:** (terminals SLOT1,2 TERMINALS: GND, AI1, GND, AI2)

$I = 0 - 25 \text{ mA}$

**Analog outputs AO - KP 100 113:** (terminals SLOT1,2 TERMINALS: AO1+, AO1-, AO2+, AO2-)

$U = 5 - 28 \text{ V}$

**B.4 Device identification of Prilog 400 for Zone 2**

**B.4.1 Production label**

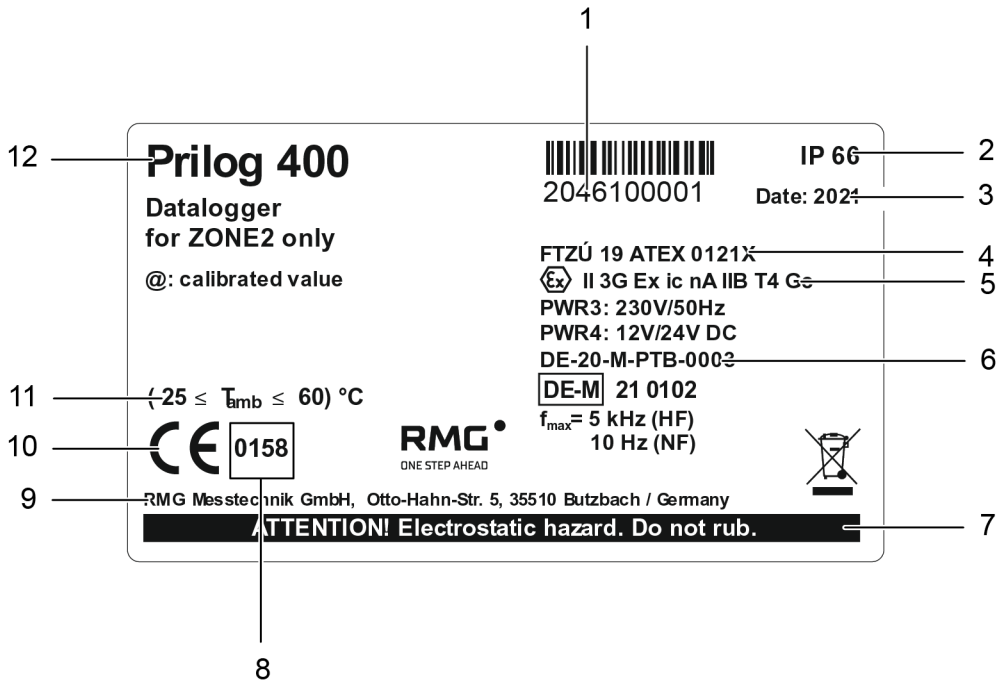

Fig. 68: Prilog 400 type plate for Zone 2 only (illustrative purposes)

Item	Designation	Item	Designation
1	Serial number of the device	7	Warning to operators
2	IP rating	8	Notified body designation
3	Year of manufacture	9	Manufacturer's address
4	EU Type examination certificate (ATEX)	10	CE conformity mark
5	Explosion protection designation	11	Ambient temperature range
6	MessEG examination certificate (metrological)	12	Device designation

**B.4.2 Additional label**

**ATTENTION – DO NOT OPEN WHEN AN EXPLOSIVE ATMOSPHERE MAY BE PRESENT**

Both labels are situated on the front part of device.

## **B.5 Product features**

### **B.5.1 Metrological characteristics and parameters**

Metrological characteristics and parameters of device Prilog 400 for Zone 2 are identical to the standard version of the intrinsically safe Prilog 400 device.

144

### **B.5.2 Technical design and characteristics**

Technical design and characteristics of the device Prilog 400 for zone 2 are almost no different from intrinsically safe but a modified version of the I/O board and the associated changes in plug-in modules are used.

Some terminals for connecting external devices are not intrinsically safe on this unit and have a “ec” type of protection. This changes the way of connecting some additional devices (communication devices, digital outputs and possibly analog inputs / outputs).

These changes are described in the following chapters.

## B.6 Technical design

### B.6.1 I/O board differences

The I/O board (position 12 in Fig. 46 of manual) contains terminal blocks for connecting external devices and slot connectors for plug-in modules. In the version for Zone 2 there are the following differences:

- does not contain SLOT 3 (S3-PWR1 cannot be used). The EVC's external power supply is via the S4N-PWR3 or S4N-PWR4 module.
- Change with SLOT 4 – the slot is designed exclusively for external power module S4N-PWR3 or S4N-PWR4 (S4-PWR2 and S4-COM0 cannot be used).
- does not contain PWR1 and PWR2 terminals. The external power supply for the EVC and the internal modem is common and is connected to the terminals directly on the S4N-PWR3 or S4N-PWR4 module.
- non-intrinsically safe terminals with 'ec' protection, ie SLOT1, SLOT2 and DOUT terminals are color coded in black from intrinsically safe terminals, and are further separated from them by a safety partition.

### B.6.2 External power supply

The EVC part of the converter can be powered from the internal battery B-03, B-03D or B-03A. In this version, the internal modem cannot be powered from the internal battery.

Only the S4N-PWR3 module or the S4N-PWR4 module is intended for external power supply of the Prilog 400 in the version for Zone 2. Both modules are designed for SLOT 4.

Note:

The S3-PWR1 and S4-PWR2 modules cannot be used for the external power supply of the Prilog 400 in Zone 2. In addition, these modules are mechanically incompatible with slot 4 connectors on the I/O board.

#### Note

**External power supply of data logger and internal modem is provided by a single module S4N-PWR3 or S4N-PWR4 simultaneously.**

**The internal modem cannot be powered from the battery.**

The **module S4N-PWR3** provides external power supply of data logger and internal modem from 230 V/AC electric network, S4-PWR4 module from DC power supply.

The **module S4N-PWR4** is actually available in one version depending on the DC supply voltage:

- The module **S4N-PWR4/24V**, powered by 24V/DC.

The technical parameters of the S4N-PWR3 and S4N-PWR4/24V modules are given in paragraph B.7 of this Annex.

The connection of the external power supply is described in section B.8.3.

### B.6.3 Plug-in modules changes in use

Slot	Plug-in modules (Prilog 400 for Zone 2)
SLOT 0	S0-SCR S0-NAM S0-EXT1 (including board EXT1-T)
SLOT 1	S1N-COM1 *) S1N-2AI *) S1N-2AO *)
SLOT 2	S1N-COM1 *) S1N-2AI *) S1N-2AO *)
SLOT 4	S4N-PWR3 S4N-PWR4/24V
SLOT 5	M2G M4G, LTE-Cat1E M4G, LTE-Cat1U M4G, LTE-CatM1U

\*) These modules are functionally identical to intrinsically safe modules, but they have terminals for connection of external devices protected by the type of protection “ec”.

Table 29: Plug-in modules, Prilog 400 for Zone 2

#### Caution

**Internal modules for positions SLOT 1 and SLOT 2, it means modules:**

**S1N-COM1,  
S1N-2AI,  
S1N-2AO,**

**they are functionally identical to intrinsically safe modules, but they have terminals for connection of external devices protected by the type of protection “ec” and are only intended for zone 2 (check the module's side rating plate).**

**Devices connected to these modules are connected to the terminals of these modules directly without using a safety barrier.**

#### Caution

**Marking and using modules for positions SLOT 1 and SLOT 2**

**Modules with marking:**

**S1N-xxxx ... not suitable for intrinsically safe device design,  
S1-xxxx ... not applicable with Prilog 400 for Zone 2.**

**Marking and using modules for position SLOT 4**

**Modules with marking:**

**S4N-xxxx ... not suitable for intrinsically safe device design,  
S4-xxxx ... not applicable with Prilog 400 for Zone 2.**

## B.7 Technical parameters – modules for external power supply

<b>S4N-PWR3 Module of external power supply data logger and internal modem</b>	
	<b>Prilog 400 for Zone 2</b>
max. count of modules in device	1
installation in EVC device	SLOT 4
module identification	providing external power to the data logger circuits and internal modem from the 230 V/AC, 50 Hz power supply network
galvanic separation	Yes
the nominal supply voltage	230 V/AC, 50/60 Hz
range of power supply voltage	100 V – 240 V/AC, 50/60 Hz
max. power input	25 W
max. input current	0.25 A
design in terms of protection against electric shock	protection class equipment II (EN 61140)
overvoltage protection	by varistor
identification of terminals for power supply connection	N, L
terminals allow to connect conductor with cross-section	0.2 – 3.3 mm <sup>2</sup>

<b>S4N-PWR4/24V Module of external power supply data logger and internal modem</b>	
	<b>Prilog 400 for Zone 2</b>
max. count of modules in device	1
installation in EVC device	SLOT 4
module identification	providing external power to the data logger circuits and internal modem from the 24V/DC power supply network
galvanic separation	Yes
the nominal supply voltage	24 V/DC
range of power supply voltage	20 V – 32 V/DC
max. input current	0.5 A
overvoltage protection	Yes
identification of terminals for power supply connection	+U, -U
terminals allow to connect conductor with cross-section	0.2 – 3.3 mm <sup>2</sup>

## B.8 Connection of inputs and outputs

Connecting the equipment to the intrinsically safe terminals is described in the main section of the manual and also applies to the Prilog 400 for Zone 2.

A different connection method applies to terminals that are not intrinsically safe but have “ec” type protection applied, i.e. terminals:

- **SLOT 1,**
- **SLOT 2,**
- **DOUT**
- **external power connection.**

It is the connection of communication, digital outputs, analog inputs/outputs and external power supply (common for data logger part and internal modem).

### B.8.1 Safety marking of terminals

The device Prilog 400 for Zone 2 has on terminals I/O board shown as intrinsically safe signals and so signals with "nA" protection. These two types of signals are distinguished by the type and color of the terminal:

Type of signal	Terminal blocks on the I/O board	Colour terminals
signal with protection “ec”	DOUT, SLOT 1, SLOT 2	black
intrinsically safe signal	all others	green (or blue)

Non-intrinsically safe terminals are separated from intrinsically safe terminals on the I / O board by a safety barrier to maintain safety distances according to EN 60079-11 (see fig. 69).

### **Warning**

**Do not open the device if it is located in a potentially explosive area!**

**Cable leads from external power supply and cable leads to DOUT, SLOT 1 and SLOT 2 terminals must not be connected/disconnected while they are under voltage!**

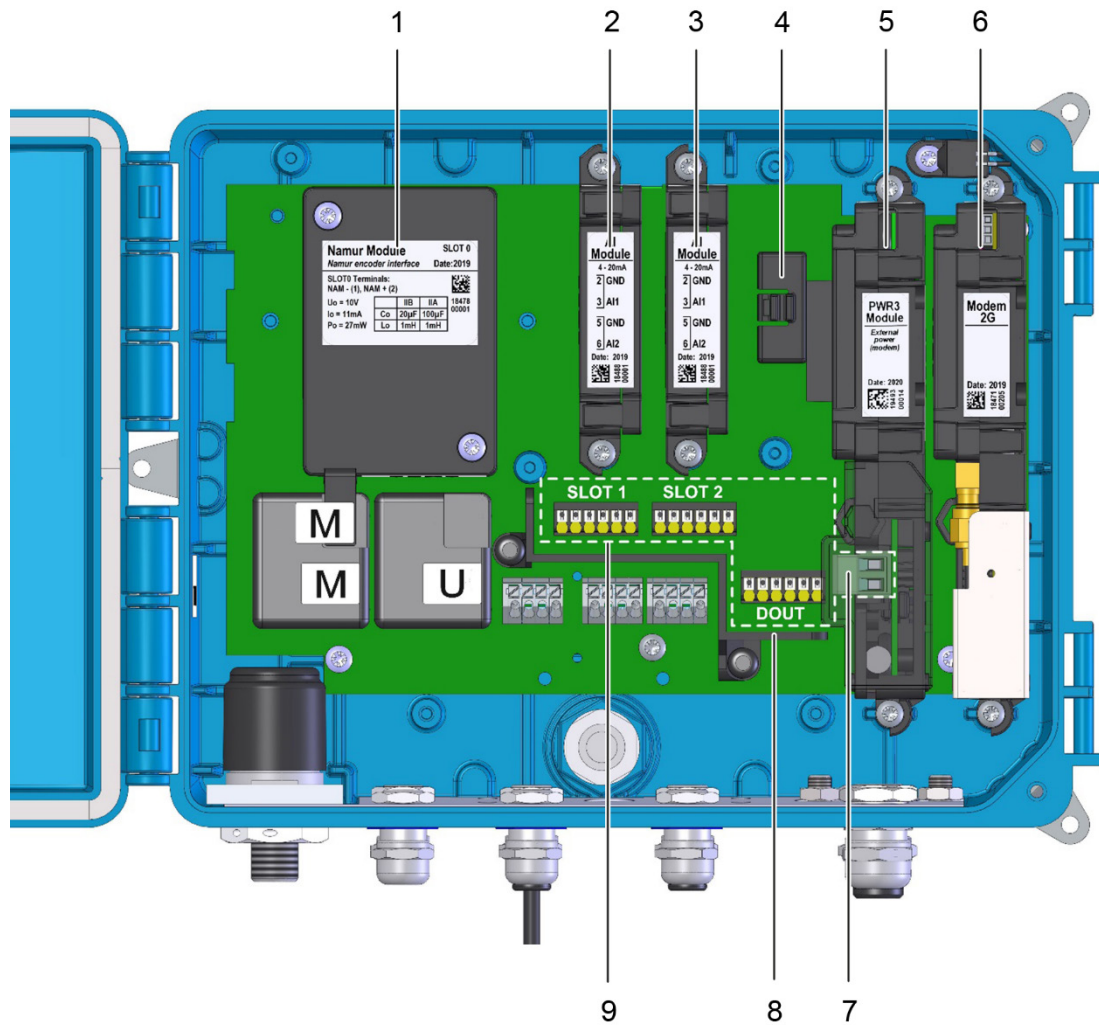

Fig. 69: Terminals with protection “ec”

Item	Designation	Item	Designation
1	SLOT 0	6	SLOT 5
2	SLOT 1	7	External power supply
3	SLOT 2	8	Barriers
4	SLOT 3 (empty)	9	Terminals with ‘ec’ protection
5	SLOT 4		

**B.8.2 Identification of cable glands**

**⚠ Caution**

The cable glands for intrinsically safe cables are marked with a blue gland nut cover on the device Prilog 400 for zone 2.

For cables with standard signals (i.e. non-intrinsically safe signals) - external power supply, communication, digital outputs and analog inputs/outputs, two PG9 cable glands, gland no. 9 and 10 are intended – see fig. 70.

For external power supply it is necessary to use separate two-core cable. When using all signals from the SLOT 1 (4-wire), SLOT 2 (4-wire) and DOUT (6-wire) terminal blocks, a 14-core cable must be used.

150

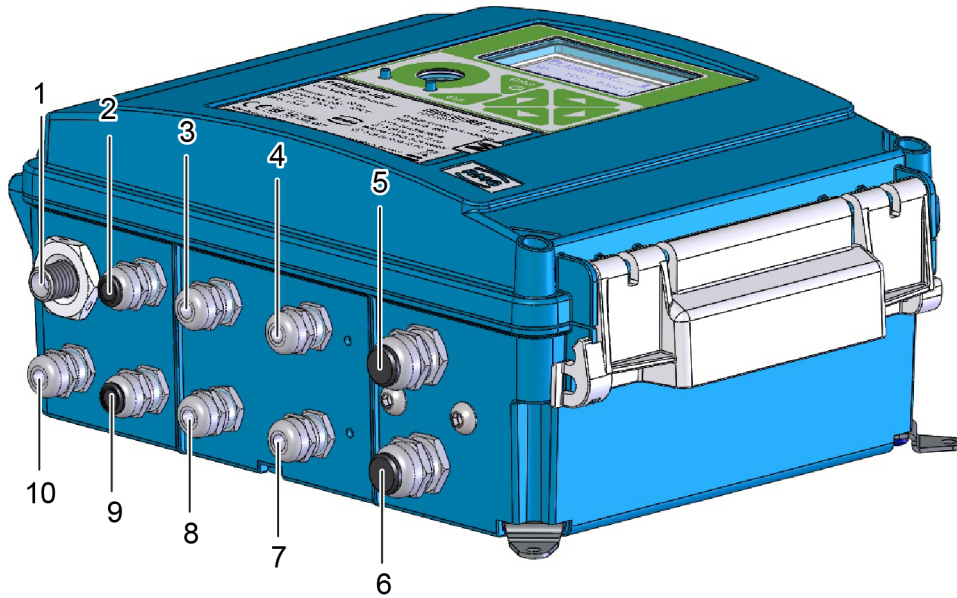

Fig. 70: The deployment of the cable gland

Item	Cable	Type of signal	Gland
1	Pressure (1. channel)	intrinsically safe	PG7
2	gas meter (1. channel)	intrinsically safe	PG7
3	gas meter (2. channel), digital inputs (DIN)	intrinsically safe	PG7
4	Communication	intrinsically safe	PG7
5	Digital outputs (DOUT), communication, event. analog input/output	Standard	PG9
6	External power supply (for device and modem)	Standard	PG9 for Ex-Zone 0/1, M20x1,5 for Ex-Zone 2
7	External pressure (2. channel)	intrinsically safe	PG7
8	Temperature (2. channel)	intrinsically safe	PG7
9	gas meter HF, encoder	intrinsically safe	PG7
10	Temperature (1. channel)	intrinsically safe	PG7

Table 30: Cable glands - recommended use for Prilog 400 for Zone2

**B.8.3 External power connection**

The instrument must have the S4N-PWR3 or S4N-PWR4 module in the SLOT4 position, depending on the type and size of the supply voltage.

**Note**

To ensure proper operation of the device, the applied supply voltage to the device must be treated for interference and overvoltage.

A surge arrester type 3 with HF filter must be used in the power supply near the device.

**⚠ Caution**

The wires of external power supply cables must be connecting without under voltage to data logger device!

There is also a risk of electric shock if the power supply is connected!

151

---



---



---



---

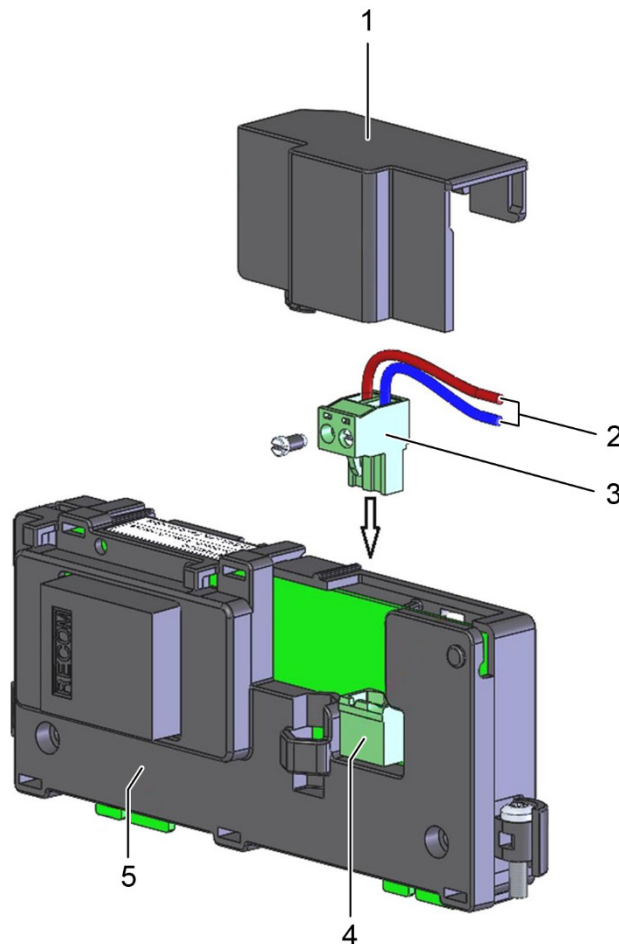

Fig. 71: Connecting of external power supply

Item	Designation	Item	Designation
1	Cover of external power supply	4	Connector-plug for external power supply to board of module
2	External power supply wires	5	Plug-in module S4N-PWR3 (S4N-PWR4)
3	Connector-plug with terminals for external power supply		

The power supply cable of the external power supply is connected to the device via cable gland (see fig. 70, item 6). Remove a cover of connector (fig. 71, item 1) from a module S4N-PWR3/S4N-PWR4 for power supply connecting. The connector-plug (fig. 71, item 3) is pulled out and the power supply wires (fig. 71, item 2) are fastened to the terminals of connector (fig. 71, item 3). Make sure the polarity of the S4N-PWR4 is correct. Check the cable clamp for tightness for moving. Insert the plug with the power cord plugged into the connector socket (fig. 71, item 4) on the module fitted in the instrument. Finally, replace the connector cover (fig. 71, item 1).

Fix the cable against being pulled out by tightening the nut cable gland (see fig. 70, item 6).

#### Note:

*Do not connect the external power supply to the terminals when the connector plug (fig. 71, item 3) is inserted into module board. The reason is mechanical stress on the connector on the board!*

Choose the power cord diameter with regard to the PG9 cable gland, which is designed for cables with a diameter of 4 to 8 mm.

In the case of **DC power supply**, we recommend using a 2-core shielded cable type UNITRONIC LiYCY with min. wire cross-section 0.25 mm<sup>2</sup> and connect its shielding to the cable gland body of the device. Do not connect the shield at the opposite end of the cable.

In case of mains power supply, select a cable with min. 0.25 mm<sup>2</sup> cross-section.

When the external power supply failure occurs, the data logger battery (B-03) performs a backup function for the data logger. The modem power is not backed up by the battery.

#### Note

**If the data logger is powered by an external power supply, it is necessary for the battery power supply module (B-03) of the data logger to be inserted and connected in the device.**

#### B.8.4 Connection of digital outputs

If several digital outputs are used, they all have the same ground. In order to galvanically isolate the outputs from each other, it is necessary to install an isolating module for each output. This also applies if devices are connected which are not approved for Ex zone 2.

For the separation, RMG recommends the isolating amplifiers IM1-12-T (available as an accessory).

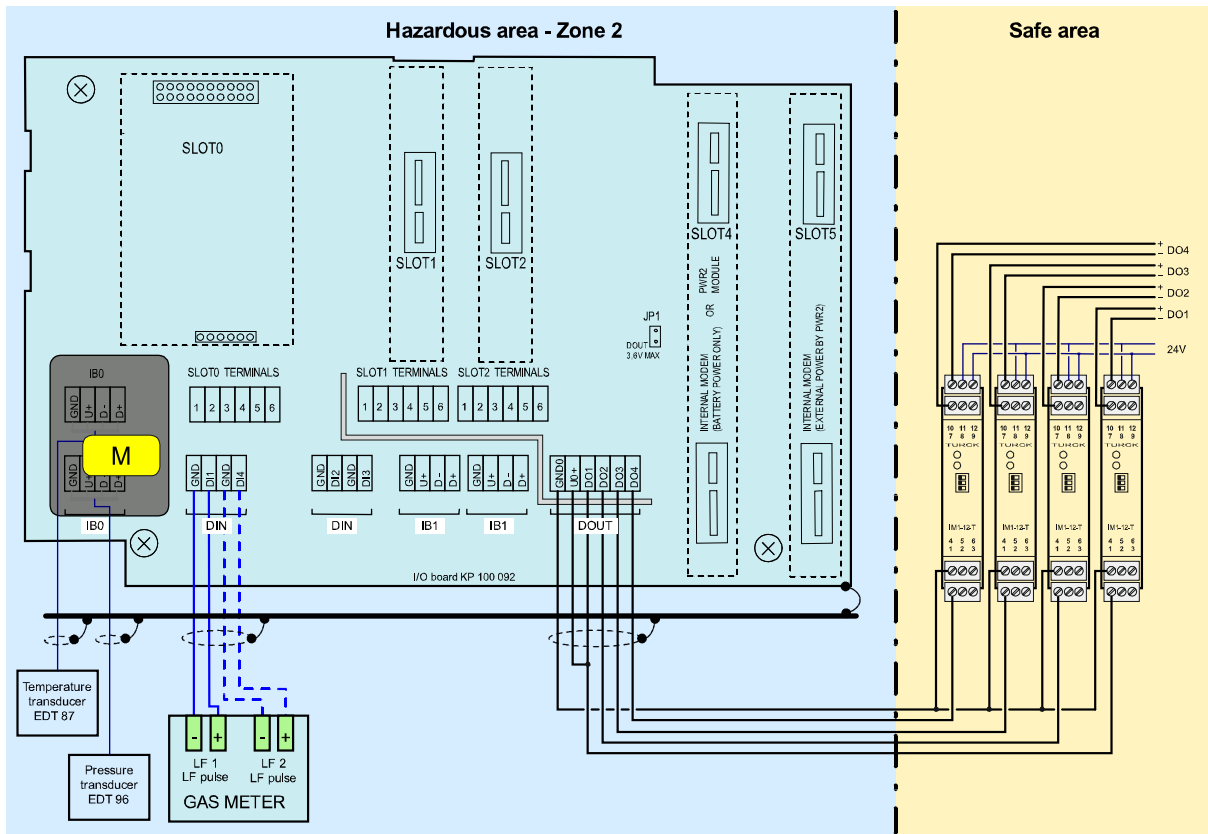

Fig. 72: Connecting digital outputs via the isolating amplifiers IM1-12-T (Prilog 400)

**B.8.5 Connection of communication devices via RS232 / RS485 interface**

For communication, Prilog 400 for Zone 2 must have at least one S1N-COM1 communication module. The module must be installed in SLOT 1 and/or SLOT 2. The module offers RS232 or RS485 communication interface. A maximum of two S1N-COM1 communication modules can be installed in the device. In this case, it is possible to communicate on two completely independent communication lines. The cable is connected to terminal block SLOT 1 and / or SLOT 2.

**Note:**

Module S4-COM0 is not possible to use in device.

SLOT 1, SLOT 2	RS232	RS485
terminal	signal	signal
1	---	D1+
2	---	D1-
3	GND	GND
4	CTS	U1+
5	RxD	---
6	TxD	---

Table 31: Terminal block assignment of SLOT 1 and SLOT 2 when fitted with S1N-COM1 module

Communication device (PC, modem, PLC automat etc.) is connecting directly with module S1N-COM1 (resp. to terminals SLOT 1 and SLOT 2) without safety isolation barrier.

We recommend using a shielded cable of the UNITRONIC LiYCY type as the connecting cable. The number of cores and the conductor cross-section depend on the required outputs and parameters of the PG9 cable gland (cable gland No. 10, see Fig. 70). The cable is common to signals from SLOT 1, SLOT 2 DOUT terminals. The PG9 cable gland is designed for cable diameters of 4 to 8 mm.

Recommended cables:

Signal	Number of cores	Recommended types of cables with max. cross section of cores	Cable diameter
only SLOT 1 or SLOT 2	4	Unitronic LiYCY 4 x 0.34 Lappkabel	5.7 mm
from SLOT 1 and SLOT 2	8	Unitronic LiYCY 8 x 0.34 Lappkabel	7.8 mm
only digital outputs DOUT (4x)	6	Unitronic LiYCY 6 x 0.5 Lappkabel	7.6 mm
from SLOT 1 (or SLOT 2) and DOUT (4x)	10	Unitronic LiYCY 10 x 0.25 Lappkabel	7.5 mm
from SLOT 1, SLOT 2 and DOUT (4x)	14	Unitronic LiYCY 14 x 0.14 Lappkabel	6.7 mm

Table 32: Recommended cables for RS232 and RS485 converters

### Recommendation:

When you connect an external modem to the device, we recommend using the RS232 communication interface to ensure full duplex communication.

In terms of data transmission, the Prilog 400 for Zone 2 is a DTE device, i.e. for the RS232 interface:

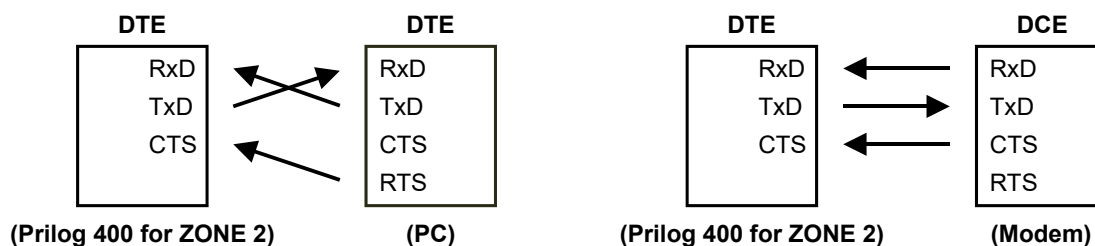

In the case of Prilog 400 for Zone 2, there is no need to use the B-RS (B-RS/A) safety barrier that included signal crossing. For this reason, it is necessary to check the correct wiring of the cables used:

**B.8.6 Connection to a network (Ethernet)**

If a connection to a network is to be made, this can be done via an external converter from RS 485 to TCP/IP. RMG recommends the Phoenix Comserver (available as an accessory) for installation outside Zone 1.

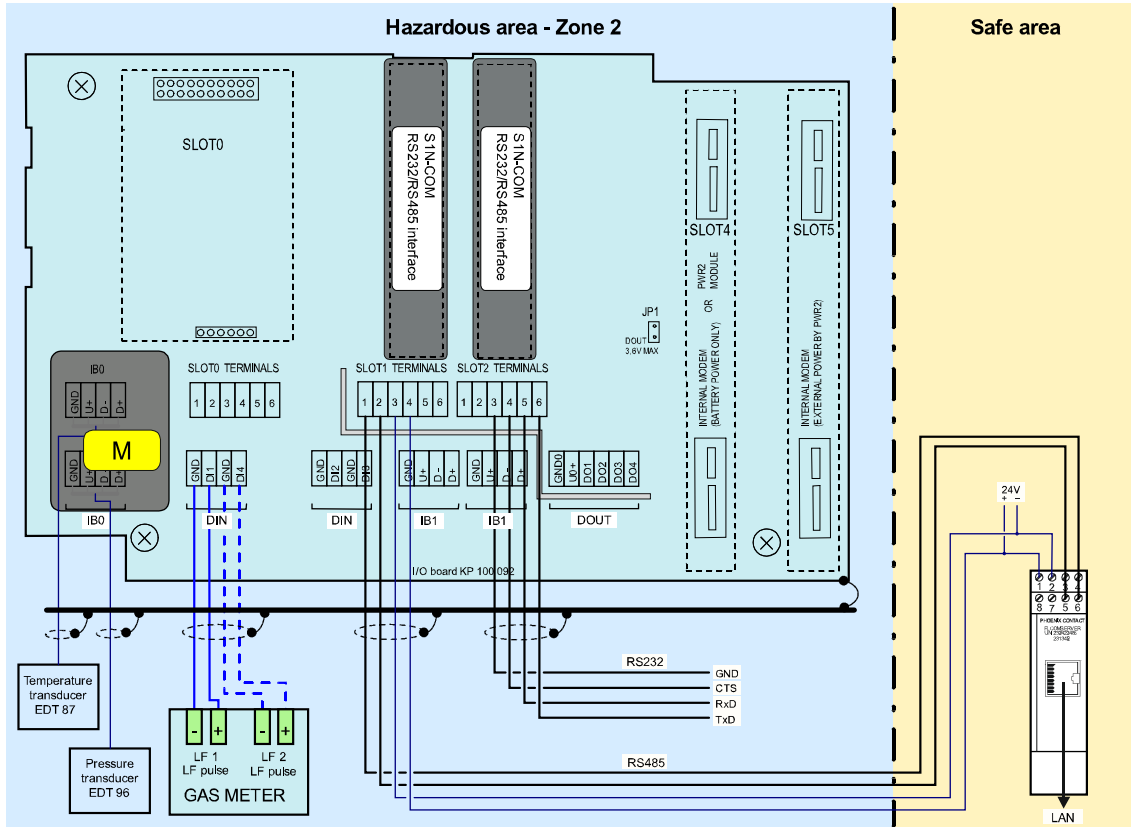

Fig. 73: Prilog 400, connection to LAN via RS485 and Comserver

Details on the configuration can be found in Appendix C.

### B.9 Examples - block diagram of connection

156

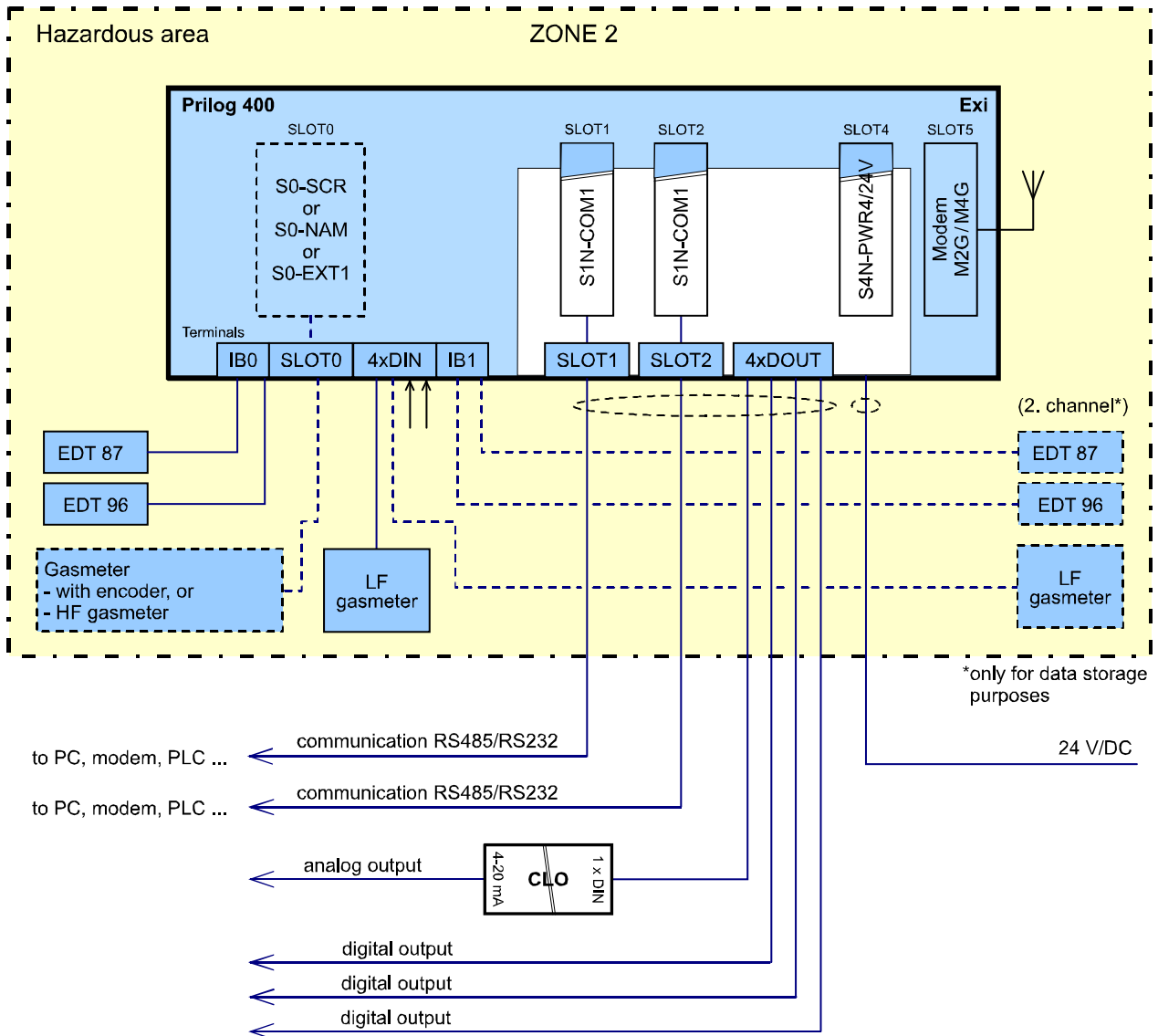

Fig. 74: Block diagram, Prilog 400 for Zone 2 with ext. 24V power supply

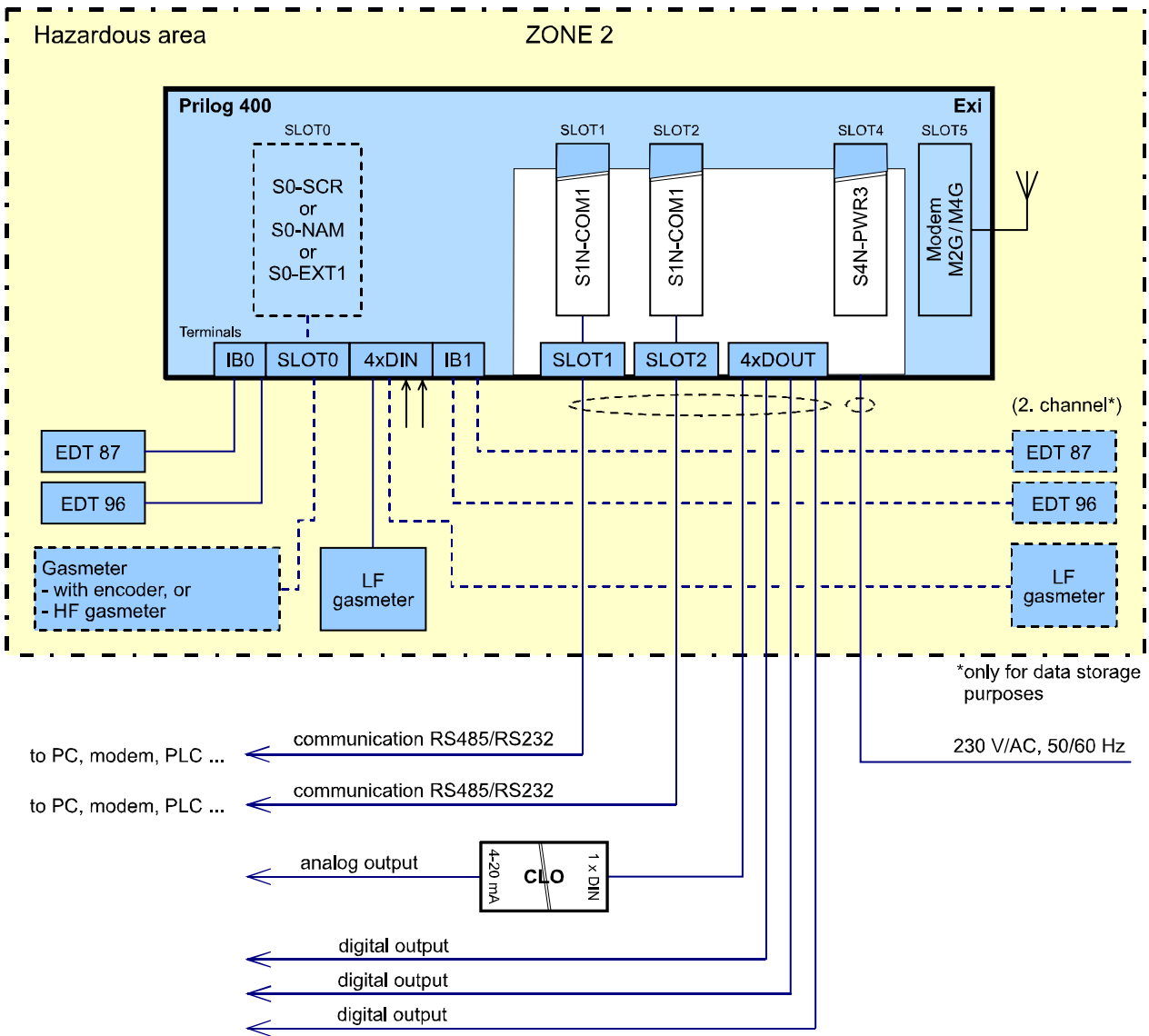
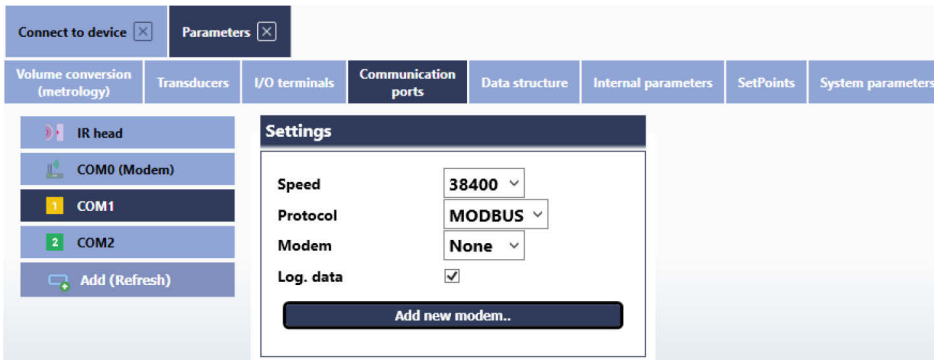

Fig. 75: Block diagram, Prilog 400 for zone 2 with ext. 230V power supply

## C Configuration Ethernet Connection via FL Comserver

Settings in RMGView prime:



158

Settings für the COMServer via Web browser:

1. Enter the IP Adresse of the FL Comserver in the search box after the Comserver is connected to your PC



2. Enter the following parameters under „General Configuration -> IP“

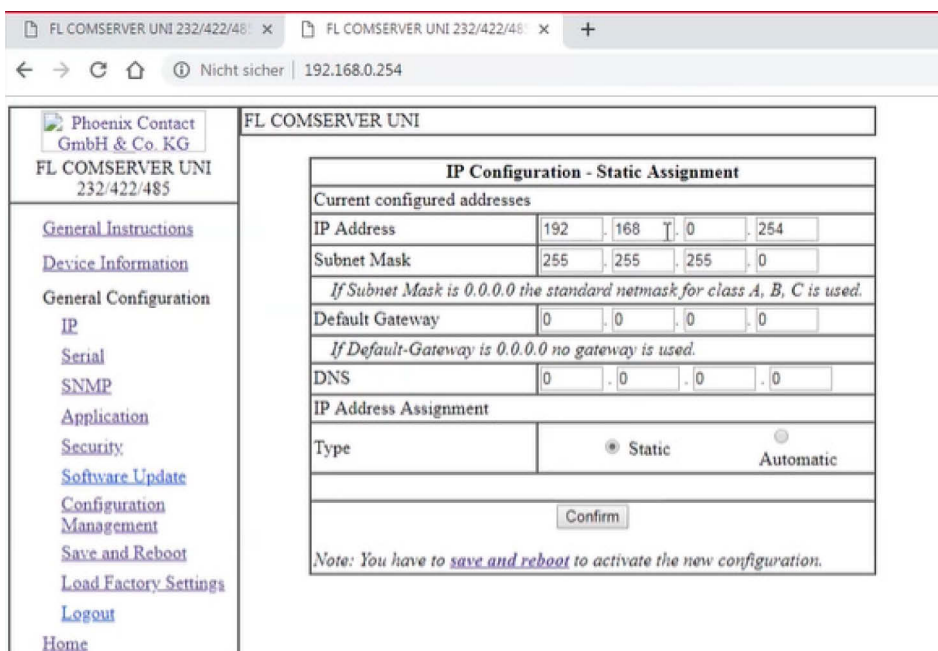

3. Enter the following parameters under „General Configuration -> Serial“

The screenshot shows the web interface for the FL COMSERVER UNI. The browser address bar shows the URL 192.168.0.254. The page title is "FL COMSERVER UNI". The left sidebar contains a navigation menu with the following items: General Instructions, Device Information, General Configuration, IP, Serial, SNMP, Application, Security, Software Update, Configuration Management, Save and Reboot, Load Factory Settings, Logout, and Home. The main content area is titled "Serial Configuration" and contains the following table:

Serial Configuration	
Interface Type	Port 2 RS-485
Baud Rate	38400
Data Bits	8
Parity	none
Stop Bits	1
Flow Control	self controlled
Switching output	RESET (Setting is NOT retained after a reboot)

Below the table is a "Confirm" button and a note: "Note: You have to save and reboot to activate the new configuration." At the bottom, there is a "Typical settings:" section with the following data:

3964 R, Phoenix Contact:	9600; 8; Even; 1; none
S7-PC Adapter:	19200; 8; Odd; 1; RTS/CTS
S7-TS-Adapter:	19200; 8; None; 1; RTS/CTS
Modbus RTU:	xxxx; 8; Even; 1; none
Modbus ASCII:	xxxx; 7; Even; 1; none

After these settings make a connection test via RMGView Prime

The screenshot shows the RMGView Prime interface. The "Parameters" tab is selected. Under "Try to connect automatically: (serial)", there is a "Connect" button. Below that, under "or manually:", there is a "Settings" table:

Settings	
Channel	TCP
IP address : port	192.168.0.254:3001
Protocol	Modbus
Address 1	248
Address 2	0

At the bottom of the settings area is a "Test connection to device" button.

## D References

- [1] EN 60079-0 ed.4: III.2013 – Explosive atmospheres - Part 0: Equipment - General requirements
- [2] EN 60079-11 ed.2:VI.2012 – Explosive atmospheres - Part 11: Equipment protection by intrinsic safety "i"
- [3] EN 60079-26 ed.3:VII.2015 – Explosive atmospheres - Part 26: Equipment with Equipment Protection Level (EPL) Ga
- [4] EN 12405-1: I.2006, +A1: II.2007 – Gas meters - Conversion devices - Part 1: Volume conversion
- [5] EN 60079-14 ed. 4: IX.2014 - Explosive atmospheres - Part 14: Electrical installations design, selection and erection
- [6] EN 61000-4-2: VII.1997 + A1: VII.1999 + Z1: XI.2001 - Electromagnetic compatibility (EMC) - Part 4-2: Testing and measurement techniques - Electrostatic discharge immunity test
- [7] EN 61000-4-3 ed.3:2006 + A1:2008+ Z1: 2010 - Electromagnetic compatibility (EMC) - Part 4-3: Testing and measurement techniques - Radiated, radio-frequency, electromagnetic field immunity test
- [8] EN 61000-4-4 ed.2:2005 - Electromagnetic compatibility (EMC) - Part 4-4: Testing and measurement techniques - Electrical fast transient/burst immunity test
- [9] EN 61000-4-6 ed.2:2008 - Electromagnetic compatibility (EMC) - Part 4-6: Testing and measurement techniques - Immunity to conducted disturbances, induced by radio-frequency fields
- [10] EN 61000-6-2 ed. 3:2006 – Electromagnetic compatibility (EMC) - Part 6-2: Generic standards - Immunity standard for industrial environments
- [11] EN 61000-6-4 ed.2:2007 - Electromagnetic compatibility (EMC) - Part 6-4: Generic standards - Emission standard for industrial environments
- [12] EN 62056-21: IV.2004 – Electricity metering - Data exchange for meter reading, tariff and load control - Part 21: Direct local data exchange
- [13] Modicon Modbus Protocol Reference Guide, Modicon Inc., Industrial Automation Systems, 1996
- [14] FTZÚ 19 ATEX 0034X - EU-Type Examination Certificate
- [15] EN ISO 12213-3:2010 - Natural gas - Calculation of compression factor - Part 3: Calculation using physical properties

## E Related Documents

- [16] RMGViewPrime – Software description. User Manual. RMG Messtechnik GmbH
- [17] EDT 96 Pressure transducer. User Manual. RMG Messtechnik GmbH.
- [18] EDT 87 Temperature transducer. User Manual. RMG Messtechnik GmbH.

## F Software

- [19] RMGViewPrime.exe, RMG Messtechnik GmbH, supplied with the device
- [20] Dialog 600.exe, RMG Messtechnik GmbH, for RMG service

## G Trade Marks Used

- {1} IrDA® - trade mark of Infrared Data Association company
- {2} ModBus® - trade mark of Modicon company

## H List of Figures

Fig. 1: Prilog 400 dimensions.....	26
Fig. 2: Internal security marks of Prilog 400.....	27
Fig. 3: External security marks of the device .....	28
Fig. 4: Data plate (for example) .....	29
Fig. 5: Mounting the brackets on the device .....	31
Fig. 6: Mounting Prilog 400 on a mounting plate .....	32
Fig. 7: Mounting the device on a pipe .....	33
Fig. 8: Installation of Prilog 400 on RMG turbine gas meter .....	34
Fig. 9: Mounting the temperature sensor on the pipe .....	35
Fig. 10: Mounting the temperature sensor using a straight weld-on fitting .....	36
Fig. 11: Connecting the cable shields in the cable glands .....	37
Fig. 12: Cable glands arrangement.....	38
Fig. 13: Connecting LF gas meter to Prilog 400 (single channel).....	41
Fig. 14: Connecting LF gas meter with the detection of rotation direction to Prilog 400.....	42
Fig. 15: Connecting HF gas meters (optionally with encoder) to Prilog 400 .....	42
Fig. 16: Connecting gas meter with NAMUR encoder to Prilog 400 .....	43
Fig. 17: Connecting gas meter with SCR encoder to Prilog 400.....	43
Fig. 18: Connecting digital outputs via B-DO separation barrier (Prilog 400) .....	45
Fig. 19: Connecting analog outputs via KFD2-STC5-Ex1 barrier (Prilog 400).....	46
Fig. 20: EDT 96 and EDT 87 transducers connection .....	47
Fig. 21: Connecting the external power supply of the data logger.....	49
Fig. 22: PS-M External power supply for the internal modem with PS-M source .....	50
Fig. 23: External power supply to the data logger and the internal modem .....	51
Fig. 24: Prilog 400, communication via two independent interfaces RS232/RS485 .....	53

Fig. 25: Prilog 400, connection to RS232 as well as to LAN via RS485 and Comserver.....	54
Fig. 26: Connecting the device battery.....	56
Fig. 27: Connecting the modem battery for Prilog 400.....	57
Fig. 28: Safety lock of connector.....	58
Fig. 29: Lift SIM card cover .....	58
Fig. 30: Insert SIM card.....	58
Fig. 31: Function of the keys .....	60
Fig. 32: Icon positions .....	61
Fig. 33: Basic navigation from the home screen .....	63
Fig. 34: Main menu of the device and the first-level submenu.....	64
Fig. 35: Example of actual values display .....	65
Fig. 36: Navigation in the archives (in this case, with archiving frequency 1 h).....	66
Fig. 37: Display of the settings archive .....	66
Fig. 38: Display of the status archive .....	67
Fig. 39: Example of the displayed information on device components .....	68
Fig. 40: Modem status display .....	71
Fig. 41: Display of the signal testing status.....	72
Fig. 42: Display: Option modem switch ON .....	74
Fig. 43: Display: Connection to the dispatch centre.....	74
Fig. 44: Display: Modem battery charge level.....	75
Fig. 45: Example of a summary status display.....	76
Fig. 46: Main parts of the Prilog 400 device.....	81
Fig. 47: Functional diagram of Prilog 400 .....	82
Fig. 48: Arrangement of Prilog 400 slots.....	83
Fig. 49: Release the safety lock.....	85
Fig. 50: Insert module .....	85
Fig. 51: Removing the end caps .....	85
Fig. 52: Release the safety lock.....	86
Fig. 53: Install external power supply.....	86
Fig. 54: Removing the end caps .....	86
Fig. 55: Modem replacement .....	87
Fig. 56: Main battery .....	92
Fig. 57: Replacing the modem battery .....	94
Fig. 58: Placing JP1 Jumper on I/O Board.....	97
Fig. 59: Connecting an external antenna .....	98
Fig. 60: External antenna cable adapter .....	99
Fig. 61: Transducer dimensions.....	103

---

Fig. 62: Processing the volumes at the gas meter revers rotation .....	105
Fig. 63: EXT1-T add-on terminal board for S0-EXT1 module .....	107
Fig. 64: Principle of connection with PC and external modem via module B-RS.....	113
Fig. 65: Entering password .....	121
Fig. 66: Prilog 400, example 1 of use of external modules .....	127
Fig. 67: Prilog 400, example 2 of use of external modules .....	127
Fig. 68: Prilog 400 type plate for Zone 2 only (illustrative purposes) .....	143
Fig. 69: Terminals with protection “ec” .....	149
Fig. 70: The deployment of the cable gland.....	150
Fig. 71: Connecting of external power supply.....	151
Fig. 72: Connecting digital outputs via the isolating amplifiers IM1-12-T (Prilog 400) .....	153
Fig. 73: Prilog 400, connection to LAN via RS485 and Comserver .....	155
Fig. 74: Block diagram, Prilog 400 for Zone 2 with ext. 24V power supply .....	156
Fig. 75: Block diagram, Prilog 400 for zone 2 with ext. 230V power supply .....	157

## I List of Tables

Table 1: Mounting plates supplied .....	32
Table 2: Weld-on fittings and thermowells appropriate for the pipe diameters .....	35
Table 3: Cable entries - recommended use .....	39
Table 4: Cables recommended to connect the gas meter .....	41
Table 5: Cables recommended to connect binary inputs .....	44
Table 6: Cables recommended to connect binary outputs to the B-DO module .....	44
Table 7: EDT 96 and EDT 87 transducers wire colors .....	47
Table 8: Cables recommended for external power supply for the data logger and the modem....	48
Table 9: Assigning the terminals of the terminal block SLOT 1 and SLOT 2 when S1-COM module is installed .....	52
Table 10: Recommended cables for RS232 and RS485 of the data logger .....	52
Table 11: Status icons of the display .....	62
Table 12: RSSI signal strength conversion table between dBm, %, and relative units .....	73
Table 13: Error Codes of the Modem .....	74
Table 14: List of events - error messages (Err indication) .....	78
Table 15: List of events - error messages (Wmnr indication) .....	79
Table 16: External power supply, components required .....	96
Table 17: Operating parameters of DO1 and DO2 outputs depending on shorting jumper JP1 ...	96
Table 18: Volume counter .....	104
Table 19: Options of digital inputs for the Prilog 400 device .....	106
Table 20: Options of analogue inputs for the Prilog 400 device.....	106
Table 21: Encoders – limitation of reading period .....	108
Table 22: Communication options of the devices (max. possibilities).....	110
Table 23: Quantities archiving options .....	117
Table 24: Service Switch Settings.....	120
Table 25: Password format .....	121
Table 26: Password Groups and their Specification .....	122
Table 27: User access level - for the "full" function of the service switch .....	124
Table 28: ASC Access Level.....	124
Table 29: Plug-in modules, Prilog 400 for Zone 2.....	146
Table 30: Cable glands - recommended use for Prilog 400 for Zone2 .....	150
Table 31: Terminal block assignment of SLOT 1 and SLOT 2 when fitted with S1N-COM1 module .....	153
Table 32: Recommended cables for RS232 and RS485 converters .....	154

# J Certificates

**EU-Declaration of Conformity // EU-Konformitätserklärung**



**We** RMG Messtechnik GmbH  
**Wir** Otto – Hahn – Straße 5  
 35510 Butzbach  
 Germany

Declare under our sole responsibility that the product is in conformity with the directives. Product is labeled according to the listed directives and standards and in accordance with the Type-Examination.

*Erklären in alleiniger Verantwortung, dass das Produkt konform ist mit den Anforderungen der Richtlinien. Das entsprechend gekennzeichnete Produkt ist nach den aufgeführten Richtlinien und Normen hergestellt und stimmt mit dem Baumuster überein.*

**Product** Load recorder and indication device for the maximum load Prilog 400  
**Produkt** Belastungs-Registriergerät und Höchstbelastungs-Anzeigegerät Prilog 400

Harmonisation Legislations <i>Harmonisierungsrechtsvorschriften</i>	EMV	ATEX
<b>EU- Directives</b> <i>EU-Richtlinie</i>	2014/30/EU	2014/34/EU
<b>Marking</b> <i>Kennzeichen</i>	---	II 1G Ex ia IIB T4 Ga II 1G Ex ia IIB T3 Ga (LTE) II 2G Ex ib IIA T3 Gb (PWR2 board) II 2G Ex ib IIB T4 Gb (SCR board) II 3G Ex ic ec IIB T4 Gc
<b>Normative Documents</b> <i>Normative Dokumente</i>	EN 61000-4-2: 2009 EN 61000-4-3: 2006 A1:2008, Z1:2010, A2: 2011 EN 61000-4-4: 2013 EN 61000-4-5: 2015 EN 61000-4-6: 2014 EN 61000-4-8: 2010	EN IEC 60079-0: 2018 EN 60079-11: 2012 EN 60079-15: 2011 EN 60079-7:2015:A1:2018
<b>EU Type-Examination issued by</b> <i>EU-Baumusterprüfung ausgestellt durch</i>	Prüfbericht/Test Report: 194300-596/2017 Vojenský technický ústav, s.p. Czech Republic	Modul B FTZÚ 19 ATEX 0034X FTZÚ 19 ATEX 0121X FTZÚ Czech Republic
<b>Approval of a Quality System by</b> <i>Anerkennung eines Qualitätssicherungssysteme durch</i>	---	Modul D BVS 23 ATEX ZQS/E139 Notified Body: 0158 DEKRA Testing and Certification GmbH



The object of the declaration described above is in conformity with Directive 2011/65/EU of the European Parliament and of the Council of 8 June 2011 on the restriction of the use of certain hazardous substances in electrical and electronic equipment.

*Der oben beschriebene Gegenstand der Erklärung erfüllt die Vorschriften der Richtlinie 2011/65/EU des Europäischen Parlaments und des Rates vom 8. Juni 2011 zur Beschränkung der Verwendung bestimmter gefährlicher Stoffe in Elektro- und Elektronikgeräten.*

**RED**

The object of the declaration described above is in conformity with Directive 2014/53/EU of the European Parliament. The following standards were used as a basis:

*Der oben beschriebene Gegenstand der Erklärung erfüllt die Vorschriften der Richtlinie 2014/53/EU (RED) des Europäischen Parlaments. Folgende Normen wurden zugrunde gelegt:  
 EN ETSI 301908-1 V15.1.1 / ETSI EN 301908-13 V13.2.1 / ETSI EN 301511: V12.5.1 / EN 18031-1:2024*

**RMG Messtechnik GmbH**  
 Butzbach, den 02.04.2026

\_\_\_\_\_  
 Thorsten Dietz  
 (CEO)

\_\_\_\_\_  
 Sascha Körner  
 (Technical Manager)

Sitz der Gesellschaft Butzbach • Registergericht Friedberg HRB 2535  
 Geschäftsführung Thorsten Dietz  
 Qualitätsmanagement DIN EN ISO 9001:2015



Physical-Technical Testing Institute  
Ostrava - Radvanice



(1) **Supplementary EU - Type Examination Certificate No.1**

(2) **Equipment or Protective Systems Intended for Use  
in Potentially Explosive Atmospheres  
(Directive 2014/34/EU)**

(3) EU - Type Examination Certificate number:

**FTZÚ 19 ATEX 0034X**

(4) Product: **Gas-Volume Conversion Device Primus 400  
Datalogger Prilog 400**

(5) Manufacturer: **RMG Messtechnik GmbH**

(6) Address: **Otto-Hahn-Straße 5, D-35510 Butzbach, Germany**

(7) This supplementary certificate extends EU - Type Examination Certificate No. FTZÚ 19 ATEX 0034X to apply to products designed and constructed in accordance with the specification set out in the Schedule of the said certificate but having any variations specified in the Schedule attached to this certificate and the documents therein referred to.

(8) The Physical-Technical Testing Institute, Notified Body number 1026, in accordance with Articles 17 of Directive 2014/34/EU of the European Parliament and of the Council, dated 26.02.2014, certifies that this product, as modified by this supplementary certificate, has been found to comply with the Essential Health and Safety Requirements relating to the design and construction of products intended for use in potentially explosive atmospheres given in Annex II to the Directive.

(9) Compliance with the Essential Health and Safety Requirements has been assured by compliance with:

**EN IEC 60079-0:2018, EN 60079-11:2012**

(10) If the sign "X" is placed after the certificate number, it indicates that the product is subject to Specific Conditions of Use specified in the schedule to this certificate.

(11) The marking of the product shall include the following:

 **II 1G Ex ia IIB T4 Ga**

(12) This certificate is valid till: **31.12.2027**

Responsible person:

  
Dipl. Ing. Lukáš Martinák  
Head of Certification Body



Date of issue: 17.03.2023

Page: 1/5

This certificate is granted subject to the general conditions of the FTZÚ, s.p.  
This certificate may only be reproduced in its entirety and without any change, schedule included.  
Physical-Technical Testing Institute, s.p., Píkartská 1337/7, 716 07 Ostrava - Radvanice, Czech Republic  
tel.: +420 595 223 111, +420 604 203 525, e-mail: ftzu@ftzu.cz, www.ftzu.cz



**Physical-Technical Testing Institute  
Ostrava - Radvanice**

**Schedule**

(13)

(14) **Supplementary EU - Type Examination Certificate No. 1  
to FTZÚ 19 ATEX 0034X**

(15) Description of the variation to the Product:

The subject of this supplementary certificate is:

- Extension of certificate validity.
- Modification of certified apparatus.

This supplementary certificate modifies the product's electrical circuitry, expands the product's capabilities and features, and adds additional add-on boards. These boards are as follows:

- Terminal board PT4W (connection four-wired temperature sensors P1000), this module is designed only to connection of sensors Pt1000.
- PCB of interface TMR (connection of HF TMR sensors inside the gas meter), this module is designed only to connection of sensors HF TMR.
- PCB interface EDT (connection of temperature and pressure converters type EDTxx), this module is designed to connect next devices to internal bus IB1.
- AMR interface board, this module is used to connect subsystems.

Expanding the possibilities of product by connecting a digital temperature sensor EDT87 production by ELGAS.

Extends the possibility to connect to all digital inputs DIN and NAMUR sensors with its own power supply.

New intrinsically safe parameters for DIN and NAMUR inputs are set

$$U_i = 5,5 \text{ V}, I_i = 1 \text{ mA}, P_i = 1 \text{ mW}, C_i = 0, L_i = 0$$

The remaining intrinsically safe parameters of the device remain unchanged.

New battery packs with user replaceable lithium cells are introduced to power the apparatus and all internal modems: B-03U, B-03DU, HB-03U 3.6Ah / 7.2Ah / 17Ah, HB-04U.

Internal modems can only be used in the device with an approved battery pack and battery cell. Modems can also be powered from an approved external power supply.

GPRS modem: HB-03 / HB-03D / HB-03U / option of external power supply PS-M

LTE-CatM1 modem: HB-03 / HB-03D / HB-03U / option of external power supply PS-M

LTE-Cat1 modem: HB-04 / HB-04U / option of external power supply PS-M

LTE-CatNB modem: HB-03U / option of external power supply PS-M

The modifications do not affect the existing equipment protection level (EPL).

Responsible person:

*Jaroslav*

Dipl. Ing. Lukáš Martinák  
Head of Certification Body



Date of issue: 17.03.2023

Page: 2/5

This certificate is granted in accordance to the general conditions of the FTZÚ, s.p.  
This certificate may only be reproduced in its entirety and without any change, schedule included.  
Physical-Technical Testing Institute, s.p., Pikartská 1337/7, 716 07 Ostrava - Radvanice, Czech Republic  
tel.: +420 595 223 111, +420 604 203 525, e-mail: ftzu@ftzu.cz, www.ftzu.cz



**Physical-Technical Testing Institute  
Ostrava - Radvanice**

168

(13)

**Schedule**

(14) **Supplementary EU - Type Examination Certificate No. 1  
to FTZÚ 19 ATEX 0034X**

(15) Description of the variation to the Product (continuing):

Intrinsically safe parameters

Digital inputs DIN (Terminals DI1, GND, DI2, GND, DI3, GND, DI4, GND)

$U_o = 6.5 \text{ V}$ ,  $I_o = 2 \text{ mA}$ ,  $P_o = 3 \text{ mW}$

Gas Group IIA:  $C_o = 100 \text{ }\mu\text{F}$ ,  $L_o = 100 \text{ mH}$

Gas Group IIB:  $C_o = 20 \text{ }\mu\text{F}$ ,  $L_o = 10 \text{ mH}$

$U_i = 5.5 \text{ V}$ ,  $I_i = 1 \text{ mA}$ ,  $P_i = 1 \text{ mW}$ ,  $C_i = 0$ ,  $L_i = 0$

Digital outputs DOUT (Terminals U0+, GND0, DO1, DO2, DO3, DO4)

$U_i = 15 \text{ V}$ ,  $I_i = 0.3 \text{ A}$ ,  $\Sigma P_i = 0.5 \text{ W}$ ,  $C_i = 3.3 \text{ }\mu\text{F}$ ,  $L_i = 0$

Internal bus IB0, IB1 (Terminals GND, U+, D+, D-)

$U_o = 6.5 \text{ V}$ ,  $I_o = 2.2 \text{ A}$ ,  $P_o = 1.1 \text{ W}$

Gas Group IIA:  $\Sigma C_o = 50 \text{ }\mu\text{F}$ ,  $\Sigma L_o = 1 \text{ }\mu\text{H}$

Gas Group IIB:  $\Sigma C_o = 24 \text{ }\mu\text{F}$ ,  $\Sigma L_o = 1 \text{ }\mu\text{H}$

Maximal cable length: 100 m

Interface SCR (Terminals SLOT0 TERMINALS: A, B)

$U_o = 8.0 \text{ V}$ ,  $I_o = 20 \text{ mA}$ ,  $P_o = 160 \text{ mW}$

Gas Group IIA:  $C_o = 100 \text{ }\mu\text{F}$ ,  $L_o = 10 \text{ }\mu\text{H}$

Gas Group IIB:  $C_o = 14 \text{ }\mu\text{F}$ ,  $L_o = 8 \text{ }\mu\text{H}$

Maximal cable length: 30 m

Interface NAMUR (Terminals SLOT0 TERMINALS: NAMUR+, NAMUR-)

$U_o = 10.0 \text{ V}$ ,  $I_o = 11 \text{ mA}$ ,  $P_o = 27 \text{ mW}$

Gas Group IIA:  $C_o = 100 \text{ }\mu\text{F}$ ,  $L_o = 1 \text{ mH}$

Gas Group IIB:  $C_o = 20 \text{ }\mu\text{F}$ ,  $L_o = 1 \text{ mH}$

$U_i = 5.5 \text{ V}$ ,  $I_i = 1 \text{ mA}$ ,  $P_i = 1 \text{ mW}$ ,  $C_i = 0$ ,  $L_i = 0$

Analog inputs AIN (terminals SLOT1,2 TERMINALS: GND, AI1, GND, AI2)

$U_i = 28 \text{ V}$ ,  $I_i = 93 \text{ mA}$ ,  $P_i = 660 \text{ mW}$ ,  $C_i = 40 \text{ nF}$ ,  $L_i = 0$

Analog outputs AO (terminals SLOT1,2 TERMINALS: AO1+, AO1-, AO2+, AO2-)

$U_i = 28 \text{ V}$ ,  $I_i = 100 \text{ mA}$ ,  $P_i = 660 \text{ mW}$ ,  $C_i = 0.46 \text{ }\mu\text{F}$ ,  $L_i = 0$

Interface RS485 (Terminals SLOT1, 2 TERMINALS: D+, D-, GND, U+)

$U_j = 10 \text{ V}$ ,  $I_j = 0.15 \text{ A}$ ,  $\Sigma P_i = 0.33 \text{ W}$ ,  $C_i = 4 \text{ }\mu\text{F}$ ,  $L_i = 0$

Interface RS232 (Terminals SLOT1, 2 TERMINALS: GND, CTS, RXD, TXD)

$U_j = 20 \text{ V}$ ,  $I_j = 0.15 \text{ A}$ ,  $\Sigma P_i = 0.46 \text{ W}$ ,  $C_i = 1 \text{ }\mu\text{F}$ ,  $L_i = 0$

External power supply PWR1 (Terminals SLOT3, PWR1+, PWR1-)

$U_i = 6.5 \text{ V}$ ,  $I_i = 0.2 \text{ A}$ ,  $P_i = 0.41 \text{ W}$ ,  $C_i = 40 \text{ }\mu\text{F}$ ,  $L_i = 1.1 \text{ mH}$

External power supply PWR2 (Terminals SLOT4, PWR2+, PWR2-)

$U_i = 6.2 \text{ V}$ ,  $I_i = 1.0 \text{ A}$ ,  $P_i = 6.2 \text{ W}$ ,  $C_i = 13 \text{ mF}$ ,  $L_i = 55 \text{ }\mu\text{H}$

Responsible person:

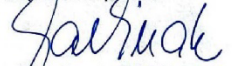
  
Dipl. Ing. Lukáš Martinák  
Head of Certification Body



Date of issue: 17.03.2023

Page: 3/5

This certificate is granted subject to the general conditions of the FTZÚ, s.p.  
This certificate may only be reproduced in its entirety and without any change, schedule included.

Physical-Technical Testing Institute, s.p., Píkatřská 1337/7, 716 07 Ostrava - Radvanice, Czech Republic  
tel.: +420 595 223 111, +420 604 203 525, e-mail: ftzu@ftzu.cz, www.ftzu.cz



**Physical-Technical Testing Institute  
Ostrava - Radvanice**

(13)

**Schedule**

169

(14) **Supplementary EU - Type Examination Certificate No. 1  
to FTZÚ 19 ATEX 0034X**

(15) Description of the variation to the Product (continuing):

TMR Interface (Slot 0, Terminals GND, U+, DI1, DI2, U+)

Uo = 6.5 V, Io = 2 mA, Po = 3 mW

Gas Group IIA: Co = 100 µF, Lo = 100 mH

Gas Group IIB: Co = 20 µF, Lo = 10 mH

EDT interface - Internal bus IB1 (Terminals Slot 0, EXT1-T: GND, U+, D+, D-)

Uo = 6.5 V, Io = 0.7 A, Po = 1.1 W

Gas Group IIA: ΣCo = 50 µF, ΣLo = 50 µH

Gas Group IIB: ΣCo = 24 µF, ΣLo = 50 µH

Maximal cable length: 100 m

AMR interface (terminals SLOT1,2: GND, U+, D-, D+)

Uo = 6.5 V, Io = 145 mA, Po = 235 mW

Gas Group IIA: ΣCo = 100 µF, ΣLo = 1.2 mH

Gas Group IIB: ΣCo = 18 µF, ΣLo = 1.2 mH

**Board EXT1**

Digital inputs DI1, DI2 (NAMUR) (terminals SLOT0 TERMINALS: DI1+, DI1-, DI2+, DI2-)

Uo = 10 V, Io = 11 mA, Po = 27 mW

Gas Group IIA: Co = 100 µF, Lo = 1 mH

Gas Group IIB: Co = 20 µF, Lo = 1 mH

Ui = 5.5V, Ii = 1mA, Pi = 1mW, Ci = 0, Li = 0

Digital inputs DI3-DI8 (terminals EXT1-T: GND, DI3, DI4, DI5, DI6, DI7, DI8)

Uo = 6.5 V, Io = 2 mA, Po = 3 mW

Gas Group IIA: Co = 100 µF, Lo = 100 mH

Gas Group IIB: Co = 20 µF, Lo = 10 mH

Ui = 5.5V, Ii = 1mA, Pi = 1 mW, Ci = 0, Li = 0

Analog inputs AIN (terminals EXT1-T: GND, AI1, GND, AI2)

Ui = 28 V, Ii = 93 mA, Pi = 660 mW, Ci = 40 nF, Li = 0

Internal bus IB1 (terminals EXT1-T: GND, U+, D+, D-)

Same parameters as IB0, IB1

Interface RS232 (terminals COM0: GND, CTS, RXD, TXD)

Ui = 20 V, Ii = 0.15 A, ΣPi = 0.46 W, Ci = 1 µF, Li = 0

Degree of protection by enclosure: IP66

Ambient temperature: -40°C ≤ Ta ≤ +70°C

Responsible person:

*Lukáš Martinák*  
Dipl. Ing. Lukáš Martinák  
Head of Certification Body



Date of issue: 17.03.2023

Page: 4/5

This certificate is granted subject to the general conditions of the FTZÚ, s.p.  
This certificate may only be reproduced in its entirety and without any change, schedule included.

Physical-Technical Testing Institute, s.p., Pikartská 1337/7, 716 07 Ostrava - Radvanice, Czech Republic  
tel.: +420 595 223 111, +420 604 203 525, e-mail: ftzu@ftzu.cz, www.ftzu.cz



**Physical-Technical Testing Institute  
Ostrava - Radvanice**

**Schedule**

(13)

(14) **Supplementary EU - Type Examination Certificate No. 1  
to FTZÚ 19 ATEX 0034X**

(15) Report Number: 19/034/1

(16) Specific Conditions of Use:

None additional to those listed previously.

(17) Essential Health and Safety Requirements:

Compliance with the Essential Health and Safety Requirements is covered by standards mentioned in clause (9) of this supplementary certificate.

(18) Drawings and Documents:

Number	Issue	Sheets	Date	Description
-	02	185	12.11.2021	User manual
KP 100_99	Z 100 018	14	20.9.2022	List of documentation KP 100
KP 108_99	Z 108 011	3	30.9.2022	List of documentation KP 108 (Primus/Prilog 400)

Responsible person:

  
Dipl. Ing. Lukáš Martinák  
Head of Certification Body



Date of issue: 17.03.2023

Page: 5/5

This certificate is granted subject to the general conditions of the FTZÚ, s.p.  
This certificate may only be reproduced in its entirety and without any change, schedule included.  
Physical-Technical Testing Institute, s.p., Pikartská 1337/7, 716 07 Ostrava - Radvanice, Czech Republic  
tel.: +420 585 223 111, +420 604 203 525, e-mail: ftzu@ftzu.cz, www.ftzu.cz



Physical-Technical Testing Institute  
Ostrava - Radvanice



(1) **Supplementary Type Examination Certificate No. 3**

(2) **Equipment or Protective Systems Intended for Use  
in Potentially Explosive Atmospheres  
(Directive 2014/34/EU)**

(3) Type Examination Examination Certificate number:

**FTZÚ 19 ATEX 0121X**

(4) Product: **Gas-Volume Conversion Device type Primus 400 for Zone 2  
Datalogger type Prilog 400 for Zone 2**

(5) Manufacturer: **RMG Messtechnik GmbH**

(6) Address: **Otto-Hahn-Straße 5, D-35510 Butzbach, Germany**

(7) This supplementary certificate extends Type Examination Certificate No. FTZÚ 19 ATEX 0121X to apply to products designed and constructed in accordance with the specification set out in the Schedule of the said certificate but having any variations specified in the Schedule attached to this certificate and the documents therein referred to.

(8) The Physical-Technical Testing Institute certifies that this product, as modified by this supplementary certificate, has been found to comply with the Essential Health and Safety Requirements relating to the design and construction of products intended for use in potentially explosive atmospheres given in Annex II to the Directive 2014/34/EU of the European Parliament and of the Council, dated 26.02.2014.

(9) Compliance with the Essential Health and Safety Requirements has been assured by compliance with:  
**EN IEC 60079-0:2018; EN 60079-7:2015:A1:2018, EN 60079-11:2012**

(10) If the sign "X" is placed after the certificate number, it indicates that the product is subject to Specific Conditions of Use specified in the schedule to this certificate.

(11) The marking of the product shall include the following:

**Ex II 3G Ex ic ec IIB T4 Gc**

(12) This certificate is valid till: **30.04.2028**

Responsible person:

*Lukáš Martinák*  
Dipl. Ing. Lukáš Martinák  
Head of Certification Body



Date of issue: 18.04.2023

Page: 1/5

This certificate is granted subject to the general conditions of the FTZÚ, s.p.  
This certificate may only be reproduced in its entirety and without any change, schedule included.  
Physical-Technical Testing Institute, s.p., Píkatřská 1337/7, 716 07 Ostrava - Radvanice, The Czech Republic,  
tel.: +420 595 223 111, +420 604 203 525, ftzu@ftzu.cz, www.ftzu.cz



**Physical-Technical Testing Institute  
Ostrava - Radvanice**

**Schedule**

(13)

(14) **Supplementary Type Examination Certificate No. 3  
to FTZÚ 19 ATEX 0121X**

(15) Description of the variation to the Product:

The subject of this supplementary certificate is:

- Modification of certified apparatus.
- Evaluation according newest standards.
- Change of type of protection "nA" to protection "ec" and `change the marking of the product.
- Extension pf certificate validity.

This supplementary certificate modifies the product's electrical circuitry, expands the product's capabilities and features, and adds new cable glands and additional add-on boards. These boards are:

- PT4W terminal board, this module is only used to connect Pt1000 sensors

Power supply modules PWR3, PWR4 are being modified to allow connection of lithium battery HB-03U in order to power the modem part in case of external power failure.

Only internal modems with an approved battery pack may be used in the device.

GPRS modem: power supply from PWR3, PWR4 module / battery backup HB-03U

LTE-CatM1 modem: power supply from PWR3, PWR4 module / battery backup HB-03U

LTE-Cat1 modem: power supply from PWR3, PWR4 module

LTE-CatNB modem: power supply from PWR3, PWR4 module / battery backup HB-03U

The modifications do not affect the existing equipment protection level (EPL).

The intrinsically safe parameters remain unchanged. The parameters at the terminals with "ec" protection are identical to the parameters of the previous "nA" protection.

Intrinsically safe parameters:

Digital inputs DIN (Terminals DI1, GND, DI2, GND, DI3, GND, DI4, GND)

$U_o = 6.5 \text{ V}$ ,  $I_o = 2 \text{ mA}$ ,  $P_o = 3 \text{ mW}$

$U_i = 5.5 \text{ V}$ ,  $I_i = 1 \text{ mA}$ ,  $P_i = 1 \text{ mW}$ ,  $C_i = 0$ ,  $L_i = 0$

Gas Group IIA:  $C_o = 100 \text{ }\mu\text{F}$ ,  $L_o = 100 \text{ mH}$

Gas Group IIB:  $C_o = 20 \text{ }\mu\text{F}$ ,  $L_o = 10 \text{ mH}$

Responsible person:

  
Dipl. Ing. Lukáš Martinák  
Head of Certification Body



Date of issue: 18.04.2023

Page: 2/5

This certificate is granted subject to the general conditions of the FTZÚ, s.p.  
This certificate may only be reproduced in its entirety and without any change, schedule included.  
Physical-Technical Testing Institute, s.p., Píkatřská 1337/7, 716 07 Ostrava - Radvanice, The Czech Republic,  
tel.: +420 595 223 111, +420 604 203 525, ftzu@ftzu.cz, www.ftzu.cz



**Physical-Technical Testing Institute  
Ostrava - Radvanice**

**Schedule**

(13)

(14) **Supplementary Type Examination Certificate No. 3  
to FTZÚ 19 ATEX 0121X**

(15) Description of the variation to the Product: (continued)

Internal bus IB0, IB1 (Terminals GND, U+, D+, D-)

U<sub>o</sub> = 6.5 V, I<sub>o</sub> = 2.2 A, P<sub>o</sub> = 1.1 W

Gas Group IIA:  $\sum C_o = 50 \mu F, \sum L_o = 1 \mu H$

Gas Group IIB:  $\sum C_o = 24 \mu F, \sum L_o = 1 \mu H$

Maximal cable length: 100 m

Interface SCR (Terminals SLOT0 TERMINALS: A, B)

U<sub>o</sub> = 8.0 V, I<sub>o</sub> = 20 mA, P<sub>o</sub> = 160 mW

Gas Group IIA: C<sub>o</sub> = 100  $\mu F$ , L<sub>o</sub> = 10  $\mu H$

Gas Group IIB: C<sub>o</sub> = 14  $\mu F$ , L<sub>o</sub> = 8  $\mu H$

Maximal cable length: 30 m

Interface NAMUR (Terminals SLOT0 TERMINALS: NAMUR+, NAMUR-)

U<sub>o</sub> = 10.0 V, I<sub>o</sub> = 11 mA, P<sub>o</sub> = 27 mW

U<sub>i</sub> = 5.5 V, I<sub>i</sub> = 1 mA, P<sub>i</sub> = 1 mW, C<sub>i</sub> = 0, L<sub>i</sub> = 0

Gas Group IIA: C<sub>o</sub> = 100  $\mu F$ , L<sub>o</sub> = 1 mH

Gas Group IIB: C<sub>o</sub> = 20  $\mu F$ , L<sub>o</sub> = 1 mH

EDT interface - Internal bus IB1 (terminals EXT1-T: GND, U+, D+, D-)

U<sub>o</sub> = 6.5 V, I<sub>o</sub> = 0.7 A, P<sub>o</sub> = 1.1 W

Gas Group IIA:  $\sum C_o = 50 \mu F, \sum L_o = 50 \mu H$

Gas Group IIB:  $\sum C_o = 24 \mu F, \sum L_o = 50 \mu H$

Maximal cable length: 100 m

TMR Interface (Slot 0, Terminals GND, U+, DI1, DI2, U+)

U<sub>o</sub> = 6.5 V, I<sub>o</sub> = 2 mA, P<sub>o</sub> = 3 mW

Gas Group IIA: C<sub>o</sub> = 100  $\mu F$ , L<sub>o</sub> = 100 mH

Gas Group IIB: C<sub>o</sub> = 20  $\mu F$ , L<sub>o</sub> = 10 mH

Board EXT1

Digital inputs DI1, DI2 (NAMUR) (terminals SLOT0 TERMINALS: DI1+, DI1-, DI2+, DI2-)

U<sub>o</sub> = 10 V, I<sub>o</sub> = 11 mA, P<sub>o</sub> = 27 mW

U<sub>i</sub> = 5.5 V, I<sub>i</sub> = 1 mA, P<sub>i</sub> = 1 mW, C<sub>i</sub> = 0, L<sub>i</sub> = 0

Gas Group IIA: C<sub>o</sub> = 100  $\mu F$ , L<sub>o</sub> = 1 mH

Gas Group IIB: C<sub>o</sub> = 20  $\mu F$ , L<sub>o</sub> = 1 mH

Responsible person:

*Lukáš Martinák*  
Dipl. Ing. Lukáš Martinák  
Head of Certification Body



Date of issue: 18.04.2023

Page: 3/5

This certificate is granted subject to the general conditions of the FTZÚ, s.p.  
This certificate may only be reproduced in its entirety and without any change, schedule included.

Physical-Technical Testing Institute, s.p., Píkatřská 1337/7, 716 07 Ostrava - Radvanice, The Czech Republic,  
tel.: +420 595 223 111, +420 604 203 525, ftzu@ftzu.cz, www.ftzu.cz



**Physical-Technical Testing Institute  
Ostrava - Radvanice**

**Schedule**

(14) **Supplementary Type Examination Certificate No. 3  
to FTZÚ 19 ATEX 0121X**

(15) Description of the variation to the Product: (continued)

Digital inputs DI3-DI8 (terminals EXT1-T: GND, DI3, DI4, DI5, DI6, DI7, DI8)

$U_o = 6.5 \text{ V}$ ,  $I_o = 2 \text{ mA}$ ,  $P_o = 3 \text{ mW}$

$U_i = 5.5 \text{ V}$ ,  $I_i = 1 \text{ mA}$ ,  $P_i = 1 \text{ mW}$ ,  $C_i = 0$ ,  $L_i = 0$

Gas Group IIA:  $C_o = 100 \mu\text{F}$ ,  $L_o = 100 \text{ mH}$

Gas Group IIB:  $C_o = 20 \mu\text{F}$ ,  $L_o = 10 \text{ mH}$

Analog inputs AIN (terminals EXT1-T: GND, AI1, GND, AI2)

$U_i = 28 \text{ V}$ ,  $I_i = 93 \text{ mA}$ ,  $P_i = 660 \text{ mW}$ ,  $C_i = 40 \text{ nF}$ ,  $L_i = 0$

Internal bus IB1 (terminals EXT1-T: GND, U+, D+, D-)

Same parameters as IB0, IB1

Parameters on terminals with protection "ec"

Digital outputs DOUT (terminals U0+, GND0, DO1, DO2, DO3, DO4)

$U_n = 28 \text{ V}$

$I_n = 100 \text{ mA}$

Interface RS485 (SLOT 1, 2 TERMINALS: D+, D-, GND, U+)

$U_n = 28 \text{ V}$

Interface RS232 (SLOT1, 2 TERMINALS: GND, CTS, RXD, TXD)

RXD:  $U_n = \pm 15 \text{ V}$

CTS:  $U_n = \pm 28 \text{ V}$

Analog inputs AIN (SLOT 1, 2 TERMINALS: GND, AI1, GND, AI2)

$I_n = 0 \div 25 \text{ mA}$

Analog outputs AO (SLOT 1, 2 TERMINALS: AO1+, AO1-, AO2+, AO2-)

$U_n = 28 \text{ V}$

Power supply 230V AC (module PWR3, TERMINALS: N, L)

$U_n = 100 \div 240 \text{ VAC}$ , 50/60 Hz

Power supply 24V DC (module PWR4/24V, TERMINALS: +U, -U)

$U_n = 20 \div 32 \text{ VDC}$

Power supply 12V DC (module PWR4/12V, TERMINALS: +U, -U)

$U_n = 10 \div 16 \text{ VDC}$

Degree of protection by enclosure: IP66

Ambient temperature:  $-25^\circ\text{C} \leq T_a \leq +60^\circ\text{C}$

Responsible person:

  
Dipl. Ing. Lukáš Martinák  
Head of Certification Body



Date of issue: 18.04.2023

Page: 4/5

This certificate is granted subject to the general conditions of the FTZÚ, s.p.  
This certificate may only be reproduced in its entirety and without any change, schedule included.  
Physical-Technical Testing Institute, s.p., Pikartská 1337/7, 716 07 Ostrava - Radvanice, The Czech Republic,  
tel.: +420 595 223 111, +420 604 203 525, ftzu@ftzu.cz, www.ftzu.cz



**Physical-Technical Testing Institute  
Ostrava - Radvanice**

**Schedule**

(13)

(14) **Supplementary Type Examination Certificate No. 3  
to FTZÚ 19 ATEX 0121X**

(16) Report Number: 19/0121/3

(17) Specific Conditions of Use:

1. Under certain extreme circumstances, the plastic enclosure may store an ignition-capable level of electrostatic charge. Therefore the device shall not be installed in a location where the external conditions are conducive to the build-up of electrostatic charge. The equipment shall only be cleaned with a damp cloth.
2. The product was tested with low risk of mechanical danger. It should be taken into consideration during transmitter installation.
3. The equipment shall only be used in an area of a least pollution degree 2, as defined in EN IEC 60664-1.

(18) Essential Health and Safety Requirements:

Compliance with the Essential Health and Safety Requirements is covered by standards mentioned in clause (10) of this supplementary certificate.

(19) Drawings and Documents:

Number:	Rev.:	Pages:	Date:	Description:
KP 100	Z 100 018	14	20.09.2022	KP 100 documentation
KP 108	Z 108 011	3	30.09.2022	KP 108 documentation

Responsible person:

*Lukáš Martinák*  
Dipl. Ing. Lukáš Martinák  
Head of Certification Body



Date of issue: 18.04.2023

Page: 5/5

This certificate is granted subject to the general conditions of the FTZÚ, s.p.  
This certificate may only be reproduced in its entirety and without any change, schedule included.  
Physical-Technical Testing Institute, s.p., Pílkartská 1337/7, 716 07 Ostrava - Radvanice, The Czech Republic,  
tel.: +420 595 223 111, +420 604 203 525, ftzu@ftzu.cz, www.ftzu.cz

*Subject to technical changes*

**More information**

If you would like to learn more about the products and solutions from RMG, visit our website:

[www.rmg.com](http://www.rmg.com)

or contact your local sales representative

**RMG Messtechnik GmbH**

Otto-Hahn-Straße 5  
35510 Butzbach, Germany  
Tel: +49 (0) 6033 897 – 0  
Fax: +49 (0) 6033 897 – 130  
Email: [service@rmg.com](mailto:service@rmg.com)