



Operating Manual

PGC9300 – Measuring Element

Status: OCTOBER 15TH, 2024
Version: 12.0

Manufacturer Our customer service is available for technical queries

Address	RMG Messtechnik GmbH Otto-Hahn-Straße 5 35510 Butzbach, Germany
Main office	+49 6033 897 – 0
Service	+49 6033 897 – 0
Spare parts	+49 6033 897 – 173
Fax	+49 6033 897 – 130
Email	service@rmg.com

Translation of the original document The **PGC9300_ME_manual_en_12.0** for the gas chromatograph PGC 9300 from October 15th, 2024 is a translation of the original German manual. Anyhow, this document may serve as reference for translations into other languages.

Remark: Please use in case of any uncertainties the German version as main reference.

Note The latest version of this manual (and the ones of other devices) can be downloaded at your convenience from our Internet page.

www.rmg.com.

Created	August	2012
1. Revised	March	2013
...		
10.	December	2021
11. Revised	October	2023
12. Revised	October	2024

Document version and language	Document version	PGC9300_ME_manual_en_12.0 October 15th, 2024
	Language	EN

Contents

1 ABOUT THIS MANUAL	1	
1.1 Structure of this manual	1	
1.2 Objective of this manual	2	
1.2.1 Abbreviations.....	2	
1.2.2 Symbols.....	3	
1.2.3 Layout of instructions	3	
1.2.4 Working with the device	4	
1.2.5 Risk assessment and minimization	9	
1.2.6 Validity of the manual	11	
1.2.7 Transport.....	12	
1.2.8 Scope of delivery.....	13	
1.2.9 Disposal of packaging material	13	
1.2.10 Storage.....	13	
1.3 Explosion-proof design	14	
1.3.1 General information.....	14	
1.3.2 Pressure-proof housing	15	
1.3.3 Connection housing with elevated safety	15	
1.4 Inspection and maintenance tasks	16	
1.4.1 General information.....	16	
1.4.2 Draining condensate from the measuring element.....	18	
1.4.3 Changing carrier gas cylinders.....	19	
1.4.4 Replacing the carrier gas filter.....	23	
2 QUICK GUIDE	26	
2.1 Mechanical connection	26	
2.2 Electrical connection	28	
2.3 Commissioning	28	
3 GAS CHROMATOGRAPH PGC 9300	29	
3.1 Type designation.....	29	
3.1.1 Suitability and safety for natural gas containing H ₂	31	
3.2 Mode of operation	32	
3.3 Configuration of the measuring element unit.....	36	
3.4 Gas flow distribution.....	39	
3.5 Gas chromatograph	40	
3.6 Analysis process.....	43	
3.7 Separating columns	48	

3.8	Area of applicability	48
3.9	Data acquisition and evaluation.....	48
3.9.1	Basic principles of the analysis	48
3.10	Required gases and gas consumption.....	50
3.10.1	Carrier gas	50
3.10.2	Calibration gas	50
3.10.3	Sample gas	51
4	CONNECTION AND COMMISSIONING	53
4.1	Electrical connections	53
4.1.1	Grounding.....	55
4.2	Gas connections	56
4.2.1	Carrier gas connection	57
4.2.2	Sample gas / calibration gas / reference gas connection	57
4.3	Column supply pressure and column temperature.....	58
4.4	Further process	58
4.5	Interruption of the carrier gas supply.....	59
5	OPERATING MODES OF THE DEVICE.....	61
5.1	Automatic operation.....	61
5.2	Stop mode.....	61
5.3	Normal calibration	61
5.4	Reference gas analysis.....	61
5.5	Basic calibration.....	62
	APPENDIX 1: TECHNICAL DATA	63
	APPENDIX 2: ERROR MESSAGES	76
	Appendix 2 A: Error during operation	76
	Appendix 2 B: Errors during recalibration	77
	Appendix 2 C: Mains failure of the GC 9300	78
	APPENDIX 3: PRE-FILTER FLUSHING UNIT	79
	APPENDIX 4: SPARE PARTS AND ACCESSORIES.....	85
	APPENDIX 5: CERTIFICATES.....	87

1 About this manual

1.1 Structure of this manual

The introduction of this manual essentially comprises three parts. The first part of the introduction lists general specifications, the symbols used in the manual and the structure of notices are presented and a risk assessment is provided. It also includes specifications for transport and storage of the gas chromatograph PGC 9300.

The PGC 9300 can be operated in explosion-protected zones. The second part of the introduction covers the conditions that must be observed for operation in such areas and describes the explosion protection.

The third part of the introduction describes recurrent inspection and maintenance tasks. Since the PGC 9300 “consumes” gases in order to be able to conduct an analysis of the gas components, these regular maintenance tasks are necessary for the proper function of the PGC 9300.

The second chapter provides brief instructions for connecting the PGC 9300. In particular, the electrical and mechanical connections are sketched. The “correct” starting up then takes place together with the controller of the GC 9300 and is described in the manual of this GC 9300.

The method of operation and the intended use of the PGC 9300 are described in the third chapter. The fourth chapter describes the electrical and mechanical connections and relevant conditions for further operation. Automated operation and the various calibrations during operation are covered in chapter 5.

The appendix contains the technical data, error messages, information about a flushing unit pre-filter, sample circuit diagrams and a summary of the approvals.

1.2 Objective of this manual

This manual provides information that is necessary for error-free and safe operation.

The gas chromatograph PGC 9300 was designed and produced according to the state of the art and generally recognized safety standards and directives. However, its use can entail dangers that can be avoided by complying with this manual. The gas chromatograph PGC 9300 must only be used as intended and in technically sound condition.

Caution

Unintended use voids all warranty claims and the gas chromatograph PGC 9300 can also lose its approvals.

1.2.1 Abbreviations

The following abbreviations are used:

ca.	circa, about
max.	maximum
min.	minimum
e.g.	for example
MID	Measurement Instruments Directive
PED (DGRL)	Pressure Equipment Directive (Druckgeräterichtlinie)
DSfG	Digitale Schnittstelle für Gasmessgeräte Digital interface for gas flow rate meters, created under the umbrella of the DVGW
DVGW	Deutscher Verein des Gas- und Wasserfaches German Gas and Water Association
MessEG	Measuring and calibration law Law on placing and providing measuring instruments on the market, their use and calibration; valid since 1.1.2015
MessEV	Measuring and calibration regulations Regulation on placing and providing measuring instruments on the market; their use and verification; 11.12.2014
PTB	Physikalisch-Technische Bundesanstalt German authority for calibration tasks

1.2.2 Symbols

The following symbols are used:

1, 2, ...	Identifies steps for work tasks
..	

1.2.3 Layout of instructions

The following notices are used:

⚠ Danger

This warning notice informs you of imminently threatening dangers that can arise due to misuse/operator error. If these situations are not avoided, death or severe injuries can occur.

⚠ Warning

This warning notice informs you of potentially dangerous situations that can arise due to misuse/operator error. If these situations are not avoided, minor injuries can occur.

⚠ Caution

This notice informs you of potentially dangerous situations that can arise due to misuse/operator error. If these situations are not avoided, damage to the device or nearby property can occur.

Note

This notice provides you with helpful tips to make your work easier. This notice also provides you with further information about the device or the work process in order to prevent operator error.

1.2.4 Working with the device

1.2.4.1 Safety instructions Danger, Warning, Caution and Note

Danger

All of the following safety notices must be observed!

Disregard of the safety notices can result in danger to the life and limb or environmental and property damage.

Bear in mind that the safety warnings in this manual and on the device cannot cover all potentially dangerous situations, because the interaction of various conditions can be impossible to foresee. Merely following the instructions may not suffice for correct operation. Always remain attentive and consider potential consequences.

- Read this operating manual and especially the following safety notices carefully before working with the device for the first time.
- Warnings are provided in the operating manual for unavoidable residual risks for users, third parties, equipment or other property. The safety instructions used in this manual do not refer to unavoidable residual risks.
- Only operate the device in fault-free condition and in observance of the operating manual.
- Compliance with local statutory accident prevention, installation and assembly regulations is also mandatory.

Caution

All notices in the manual must be observed.

Use of the gas chromatograph PGC 9300 is only permitted in accordance with the specifications in the operating manual.

RMG assumes no liability for damages arising due to disregard of the operating manual.

Danger

Service and maintenance tasks or repairs that are not described in the operating manual must not be carried out without prior consultation with the manufacturer.

Observe the following, in particular:

- Changes to the gas chromatograph PGC 9300 are not permitted.
- The technical specifications must be observed and followed for safe operation (*Appendix 1: Technical data*). Performance limits must not be exceeded.
- For safe operation, the gas chromatograph PGC 9300 must only be used in the scope of the intended use (*Chapter 3 Gas chromatograph PGC 9300* and *3.8 Area of applicability*)
- The PGC 9300 complies with current standards and regulations. However, danger can arise with misuse and the measuring element of the PGC 9300 can be destroyed due to operator error.

1.2.4.2 Dangers during commissioning

Initial commissioning	The initial commissioning must only be carried out by specially trained personnel (training by RMG) or RMG service personnel.
-----------------------	---

Note

In accordance with Article 15 of the German Ordinance on Industrial Safety and Health (Betriebssicherheitsverordnung), Article 5 of German Social Accident Insurance (DGUV) REGULATION 3 “Electrical systems and equipment” and generally recognized good engineering practices, particularly the VDE standards VDE 0100-100 “Construction of low-voltage systems” and VDE 0165 “Electrical explosion protection”, an inspection of the measuring system must be carried out before the device is commissioned. An acceptance test certificate and corresponding test report must be created for this commissioning.

These, the operating manual and the CE Declaration of Conformity must be stored so that they are always readily available. In the process, the entire documentation, including the conformity declarations and certificates must be checked for completeness.

Danger



This symbol is used in the manual as a warning of the danger of explosion; observe the instructions following the symbol.

With the danger of explosion, the following must be observed, in particular:

- Install the device as specified in the operating manual. If the device is not installed as specified in the operating manual, there may be a risk that other connected devices do not have adequate explosion protection.

The explosion protection is lost!

- Inadequately qualified persons working on the equipment are unable to correctly estimate dangers. Explosions can be triggered. Only work on the equipment if you have the appropriate qualifications.
- Components can be damaged if you do not use suitable tools and materials. Use tools that are recommended for the respective work in the operating manual.

Mechanical installation	Mechanical installation must only be performed by appropriately qualified technicians.
Electrical installation	Installation on electrical components must only be carried out by qualified electricians.
Mechanical and/or electrical installation	These qualified personnel require training specifically for work in hazardous areas. Qualified personnel are persons who have training / education in accordance with DIN VDE 0105, IEC 364 or comparable standards .

⚠ Caution

Before connecting the power supply, ensure that all gas lines to the measuring element and the measuring element itself have been flushed. If there is still air in the line system or the measuring element, the measuring element will be destroyed. For this reason, you must also consider the operating manual for the PGC measuring element CP 4900!

⚠ Danger

Connection of pressurized pipelines must only be carried out by trained qualified personnel.

Note

In order to comply with protection class IP 65 for the products of the PGC93xx family, a gooseneck pipe or by attaching a suitable piping must be connected to the outlet of the vent valve to protect it against the ingress of dirt and rain.

It must be ensured that this function is provided during installation.

⚠ Caution

The vent and outlet pipes on the top of the housing must not be closed during operation. All sealing plugs or dummy plugs at these two outlets must be removed!

Observe the following:

- Proof of competence of trained qualified personnel and the RMG test report of solder-free pipe fittings must be submitted by the installation company for the commissioning.
- All lines carrying gas must be inspected for tightness and documented in a test report prior to commissioning.

Minimum test pressure of 1.1 times the operating pressure.

- The measuring system must be checked for completeness prior to commissioning.
- Anchor the PGC 9300 on the floor to ensure that it is stable. For this purpose, use clamps or brackets to fasten it to the floor. There are fastening eyes in the rear of the feet to accommodate mounting on the wall or a ground beam.
- Connection of the gas chromatograph PGC 9300 must only take place in an explosion-free, pressure-free atmosphere. The descriptions in the operating manual must be observed for the installation process.
- In general, the setup, connection or replacement of a gas chromatograph PGC 9300 must only be carried out by RMG Service.
- A leak test must be carried out after work on pressurized components.
- All of the above points also apply to repair and maintenance tasks and in general when connection or disconnection of the gas chromatograph PGC 9300 is necessary.
- Flange fastening elements, fastening screws, screw couplings and check valves, the oil supply, pressure relief connections, valves, protective pipes and swivel adapters must not be loosened during operation.

1.2.4.3 Dangers during maintenance and repair

Operating personnel	The operating personnel use and operate the device in the scope of the intended use.
Maintenance personnel	Work on the device must only be carried out by qualified personnel who can carry out the respective tasks on the basis of their technical training, experience and familiarity with the applicable standards and requirements. These qualified personnel are familiar with the applicable statutory regulations for accident prevention and can independently recognize and avoid potential dangers.
Maintenance and cleaning	Maintenance and cleaning must only be performed by appropriately qualified technicians.

⚠ Danger

Inadequately qualified persons working on the equipment are unable to correctly estimate dangers. Explosions can be triggered. If work on live equipment must be conducted in hazardous areas, sparks that are created can trigger an explosion.

Only work on the equipment if you have the appropriate training and qualifications.

⚠ Caution

The device can be damaged if it is not cleaned as specified in the operating manual. Only clean the device as specified in the operating manual.

- Only clean the device with a slightly damp cloth!

⚠ Danger

The gas chromatograph PGC 9300 must only be used as intended! (Chapter 3 *Gas chromatograph PGC 9300* and 3.8 *Area of applicability*).

⚠ Danger

Prevent use of the gas chromatograph PGC 9300 as a potential climbing aid or use of attachments of the PGC 9300 as potential handles!

9

1.2.4.4 Qualification of the user

In general, the following is recommended for all persons working with or on the gas chromatograph PGC 9300:

- Training / education for work in hazardous areas.
- The capacity to be able to correctly estimate dangers and risks when working with the gas chromatograph PGC 9300 and all connected devices. Possible dangers include components that are under pressure and consequences of incorrect installation.
- Recognition of dangers that can arise from the flow medium that is used.
- Training / education by RMG for work with gas measuring devices.
- Education / instruction in all national standards and directives to be complied with for the work to be carried out on the GC 9300 analytical computer.

1.2.5 Risk assessment and minimization

According to assessment by qualified employees of RMG, the gas chromatograph PGC 9300 is subject to risks during its use. Risks can also arise due to high pressures and occasionally due to pressures that are too low. Work outside of the permissible temperature range can also lead to dangers. Impermissible current and voltage values can trigger explosions in hazardous areas. The risk assessment requires an emptying and ventilation of the pipeline for connection of a PGC 9300. Then and only then it is assured that there is not an explosive gas mixture in the pipeline. Naturally, work must only be carried out by trained personnel (see chapter 1.2.4.4 *Qualification of the user*) who are also trained to recognize suitable tools and use them exclusively. These risks were summarized alongside development and measures were taken to minimize these risks.

Measures for risk minimization:

- The maximum operating pressure and the permissible temperature range are specified on the type plate of the device. Operation of the device is only permitted within these specified ranges.

10



The following applies for work in hazardous areas (all zones):

- Only tools that are approved for Ex Zone 1 are permitted for maintenance and repair tasks. Components can be damaged if you do not use suitable tools.

The explosion protection is lost.

- Otherwise, work must only be carried out when there is not an explosive atmosphere.
- The risk of ignition due to impact or friction must be avoided.
- The wiring from and installation of the gas chromatograph PGC 9300 in hazardous areas must only be carried out by trained personnel in accordance with EN60079-14 and in observance of national regulations.
- Qualified persons must satisfy the definitions in accordance with DIN EN 0105 or IEC 364 or directly comparable standards.
- Only trained and instructed personnel are permitted. Work on the measuring system must only be carried out by qualified persons and inspected by responsible qualified supervisors.
- Qualified persons have been authorized by the person responsible for safety of personnel to carrying out such work on the basis of their training, experience or instruction and familiarity with applicable standards, provisions, accident prevention regulations and system conditions. It is essential that these persons are able to recognize and avoid potential dangers in good time.

1.2.6 Validity of the manual

This manual describes the gas chromatograph PGC 9300. The gas chromatograph

PGC 9300 is only part of a complete system. The manuals of the other components of the system must be observed, too. If you find contradictory instructions, contact RMG and/or the manufacturers of the other components.

⚠ Caution

Ensure that the power data of the current connection matches the specifications on the type plate. Observe any applicable national regulations in the country of use. Use cable that is appropriate for the cable fittings (see chapter 4.1. *Electrical connections*)

1.2.6.1 Danger during operation

Observe the specifications of the system manufacturer and/or system operator.

1.2.6.2 Dangers of operation in EX areas

⚠ Danger

- **Only use the gas chromatograph PGC 9300 in its original condition.**

- Only operate the gas chromatograph PGC 9300 in fault-free and complete condition. If you make technical changes to the device, safe operation can no longer be guaranteed.
- When connecting additional measuring components or additional equipment in hazardous areas, ensure that the appropriate explosion protection is provided for these components.
- They are intrinsically safe devices for which galvanic isolation must be provided with connection of these devices.

The gas chromatograph PGC 9300 is permitted for operation in Ex Protection Zone 1, but only within the permissible temperature range (*Appendix 1: Technical data*).

1.2.6.3 Responsibility of the operator

As the operator, you must ensure that only adequately qualified personnel work on the device. Ensure that all employees who work with the device have read and understood this manual. You are also obligated to train personnel regularly and inform them of the dangers. Ensure that all work on the device is carried out exclusively by qualified persons and inspected by responsible qualified supervisors. The responsibilities for installation, operation, fault rectification, maintenance and cleaning must be clearly regulated. Instruct your personnel with regard to the risks involved with working with the device.

Suitable personal protective equipment must be used for work on the PGC 9300 that you, as the operator, must provide. This applies despite the fact that all sharp edges on the device were removed as far as possible.

1.2.7 Transport

Warning

The PGC 9300 is a highly technical, quality device with glass tubes and delicate connections that partially contain flammable, explosive gases.

Therefore, any transport of the chromatograph must be carried out carefully and cautiously!

The device is packaged specific to the transport requirements for each customer. Ensure safe packaging that absorbs light impact and vibrations is used for any further transport. Nevertheless, inform the transport company that all types of impact and vibrations should be avoided during transport.

The following applies in particular for transport:

- Impact and vibrations must be avoided
- Protect the PGC 9300 from moisture
- Transport must only take place with the device lying on its back
- Transport the PGC 9300 secured on a pallet with wedges and tensioning belts, secured against movement and toppling over
- If you suspect that transport has taken place incorrectly or that damage has occurred during transport, please contact the RMG service department immediately

 Danger
Risk of injury during transport.

- Only use support and frame elements to lift the PGC 9300.
- Please observe the relevant permissible loads for the lifting equipment (see chapter *Appendix 1: Technical data*).
- Prior to lifting, ensure that the load is securely fastened.
- Do not stand under suspended loads.
- The device can slip, topple over or fall down when being lifted and set down. The device can fall over if the bearing capacity of the lifting equipment is disregarded. There is a risk of severe injury for nearby persons.
- If the device is delivered on a Euro pallet, the device can be transported on the pallet using a pallet truck or forklift.

1.2.8 Scope of delivery

The scope of delivery can differ depending on the optional orders. The following is “normally” included in the scope of delivery (only the PGC9300):

Part	Quantity
Gas chromatograph PGC 9300	1
Manual	1
...	...

1.2.9 Disposal of packaging material

Dispose of the material in an environmentally friendly manner in accordance with national standards and directives.

1.2.10 Storage

Avoid extended periods of storage. The PGC 9300 is a high-precision measuring device that should not be stored for an extended time. A new factory calibration may be necessary after an extended period of storage (longer than 4 weeks). Inspect the gas chromatograph PGC 9300 for damage and correct function after

storage. Contact the RMG service department to arrange for inspection of the device after a storage period of longer than one year. For this purpose, send the device to RMG.

However, if storage is necessary, the following must be observed:

- The PGC 9300 must be positioned upright after it has been unloaded
- The PGC 9300 must be secured against movement and tipping over
- Storage in an air-conditioned and dry environment is required due to the sensitivity to moisture
- All supply and discharge lines for gas must be sealed during storage (condition as delivered). If applicable, seal the lines with sealing plugs or dummy plugs.
- Installation must be carried out by qualified personnel only.
- If storage times of longer than 4 weeks are necessary, a permanent carrier gas flush must be provided.
An alternative storage is described in *chapter 4.5 Interruption of the carrier gas supply*.
- Any form of improper storage can result in damage and necessitate a new factory calibration

1.3 Explosion-proof design

1.3.1 General information

The process gas chromatograph PGC 9300 in Ex version is an explosion-proof electrical device with ignition protection type “pressure-proof enclosure” with connection housing of the ignition protection type “elevated safety”.

Code:  II 2G Ex db e IIB+H₂ T5 / T4 Gb

The device conforms to the requirements of Directive 94/9/EC.

Danger

The PGC 9300 is permitted for installation in hazardous areas in Zone 1 that are endangered by gas and vapor assigned to explosion group IIB+H₂ and temperature class T4 or T5.

The applicable regulations and provisions must be observed for installation and operation. The device is approved for operation in hazardous areas. The permissible electrical data and specifications for the temperature range are listed in *Appendix 1: Technical data*.

⚠ Caution
The device must be protected from direct weather influences.

1.3.2 Pressure-proof housing

⚠ Danger
The pressure-proof housing has no interlocking switch. Before opening the housing, ensure that the voltage has been switched off and observe a wait time of one minute. (See information on the type plate)

1.3.3 Connection housing with elevated safety

⚠ Danger
Ensure the correct power supply for electrical connection of the device (see specifications on the type plate).

⚠ Danger
Only certified cable connections with a male thread of M20 x 1.5 are permitted for use. The cable diameter of the supply lines must lie within the clamping range of the cable gland. Unused openings for cable input must be sealed with shockproof sealing plugs secured from independently loosening and turning. When sealing, it must be ensured that the seals remain effective in order to maintain the IP 65 protection rating.

1.4 Inspection and maintenance tasks

1.4.1 General information

Note

Explosion-proof electrical control units must be maintained on a regular basis.

The time intervals for this inspection depend on the operating and environmental conditions. We recommend at least one inspection per year (e.g. in connection with the annual calibration of the PGC 9300).

The following **recurrent** maintenance tasks require knowledge that is described in the further course of the manual. Therefore, please read the entire manual or search for the appropriate chapter in the table of contents.

All maintenance intervals and tasks are listed in the **accompanying** book of maintenance logs. The measures described there are prerequisite for the calibrated operation of the device and any warranty claims.

Note

Manual, book of maintenance logs, acceptance inspection certificate and test logs must remain accessible within the vicinity of the PGC 9300 and always readily available (see also chapter 1.2.4.2 *Dangers during commissioning*).

All measures must be documented, particularly maintenance tasks.

Danger

If it is necessary to open a pressure-proof housing, suitable measures must be taken to assure that the housing is not exposed to an explosive atmosphere.

⚠ Danger

Work on live equipment in hazardous areas is prohibited as a fundamental principle (except for intrinsically safe power circuits).

17

In special cases, work can also be carried out on live equipment in hazardous areas if it has been assured that an explosive atmosphere is not present. This must only take place with approved, explosion-proof measuring devices.

⚠ Danger

If access to electrical assemblies of the analytical computer or measuring element is necessary, the following precautionary measures must be taken:

- **The entire device must be disconnected from the power supply.**
- **When working with electronic assemblies, a connection between a grounded object and the body must be established.**

To interrupt the carrier gas supply, refer to chapter 4.5 Fehler! Verweisquelle konnte nicht gefunden werden..

Note

Pay attention to accumulation of water in the housing because the explosion-proof housing is only conditionally protected from water by the gap protecting against ignition sparks (IP65).

Rusted or corroded gaps must not be cleaned with grinding materials or wire brushes; chemical means must be used, such as reducing oils. Then acid-free anti-corrosive agents, such as ESSO RUST BAN 397, Mobil Oil Tecrex 39 or equivalent products must be applied to the gaps for protection.

⚠ Danger

The seal for the Ex-e housing must be inspected for damage and replaced as necessary.

Check cable connections and sealing plugs for tight seating.

Damage to the housing can negate the Ex protection!

If part of the device that is essential for Ex protection is repaired, the device cannot be re-commissioned until it has been inspected by a recognized qualified expert (chapter 1.2.4.4 *Qualification of*).

If repairs are carried out by the manufacturer, acceptance by a qualified expert is not necessary.

1.4.2 Draining condensate from the measuring element

There is a diaphragm filter on the measuring element with a condensate collection container (*Figure 6: Gas chromatograph PGC 9300 and Figure 5: Separation of Ex zones, Pos. 6, one per gas stream, standard for biogas, optional for natural gas*). From time to time it is necessary to drain condensate from the drain valves under the containers.

For this purpose, first **close the corresponding inlet valve on the measuring element** and open the respective drain valve for about 10 seconds.

⚠ Danger

The line contains explosive gas under a line pressure of approx. 3 bar.

The interval is determined by the humidity of the measuring gas. The optimal interval is determined by initially draining the condensate in short intervals (e.g. weekly). With lower quantities of emerging condensate, the interval can be extended until the amount of condensate is approximately half of the volume of the collecting container.

⚠ Caution

Do not open drain valves while an analysis is in progress, because this causes a pressure drop in the measuring element and disturbs the analysis. Instead, set the operating mode to “STOP” and wait until the end of the current analysis or open during calibration (duration: about 10 min).

1.4.3 Changing carrier gas cylinders

An inlet pressure of 5.5 bar for the carrier gas is required for operation of the PGC 9300. This value must not be undercut by more than 10%; any values below that level will trigger an alarm. Since the carrier gas also has a protective function and protects the measuring element from the penetration of oxygen, this situation should never arise! However, if this should occur, the measuring element switches off automatically in the range between 2 and 3 bar.

⚠ Caution

If an automatic shut-off takes place, it must be taken into consideration that air may have penetrated into the measuring element. In this case, the power supply must be switched off prior to replacing the cylinder, because the measuring element will switch itself on again if there is sufficient pressure.

The measuring element must be flushed for at least 15 minutes after cylinder replacement. If an alarm message is issued after recommissioning, a service call by RMG is required.

Cylinder replacement should take place on notification of an empty cylinder from the contact manometer.

⚠ Caution

The instructions at the cylinder frame must be observed for cylinder replacement.

Air must be prevented from entering the system during cylinder replacement!

Switchover unit for uninterrupted operation

The switchover unit guarantees uninterrupted carrier gas supply when two filled carrier gas cylinders are connected. A cylinder is selected for extraction during operation. Once this cylinder undercuts the minimum cylinder pressure (switchover pressure) setting, the unit automatically switches to the other (still full) cylinder so that the empty cylinder can be replaced. The selector switch located in the middle determines the cylinder from which gas is extracted (if neither of the two cylinders is below the minimum pressure setting).

Cylinder replacement

Carry out the following steps in the specified sequence in order to replace a gas cylinder. The same procedure must also be used for commissioning in order to connect and flush two cylinders in succession. These instructions describe the procedure for the exchange of the left cylinder identified with the letter A. To exchange the right cylinder B, replace A with B in the description.

1. Set the selector switch to cylinder B (arrow points to cylinder B) to replace cylinder A!
2. Close the cylinder valve of A and extraction valve 2A.
3. Open vent valve 1A and close it again after pressure equalization.

Caution

ATTENTION: (Carrier-) gas emerges at the cylinder pressure!

4. Remove the empty cylinder A and connect the full replacement cylinder A.
5. Open the cylinder valve of A and then close it again.
6. Open vent valve 1A and close 1A again after pressure equalization.

Caution

ATTENTION: (Carrier-) gas emerges at the cylinder pressure!

7. Carry out steps (5.) and (6.) two additional times in order to flush the air out of the high-pressure area.
8. Open cylinder valve A and then extraction valve 2A.

At the time of commissioning or if both cylinders must be replaced, carry out steps 1. to 9. for cylinder A and for cylinder B in succession. If the line between the switchover unit and valve 2A or valve 2B has not been vented (e.g. with a cylinder replacement during normal operation), the procedure is now finished. Otherwise (e.g. during commissioning), the following steps must be carried out afterwards in order to flush the air out of the entire system.

9. While the carrier gas inlet valve is closed, unscrew the screwed connection at the carrier gas inlet of the PGC until the carrier gas can escape unimpeded. In the process, do not completely unscrew the cap nut.
10. At the secondary pressure regulator of the switchover unit, adjust the extraction pressure as close to 5.5 bar as possible
11. Allow the carrier gas to flow out under extraction pressure for about 2 minutes.
12. Switch the selector switch to the opposite position (cylinder) and allow the carrier gas to flow out for an additional 2 minutes in order to ensure that the air is flushed out of both sides of the switchover unit.
13. Re-tighten the screw connection on the carrier gas inlet of the PGC.
14. Check all lines to ensure that there are no leaks.
15. Use the selector switch to select the cylinder that should be used for extraction during operation.

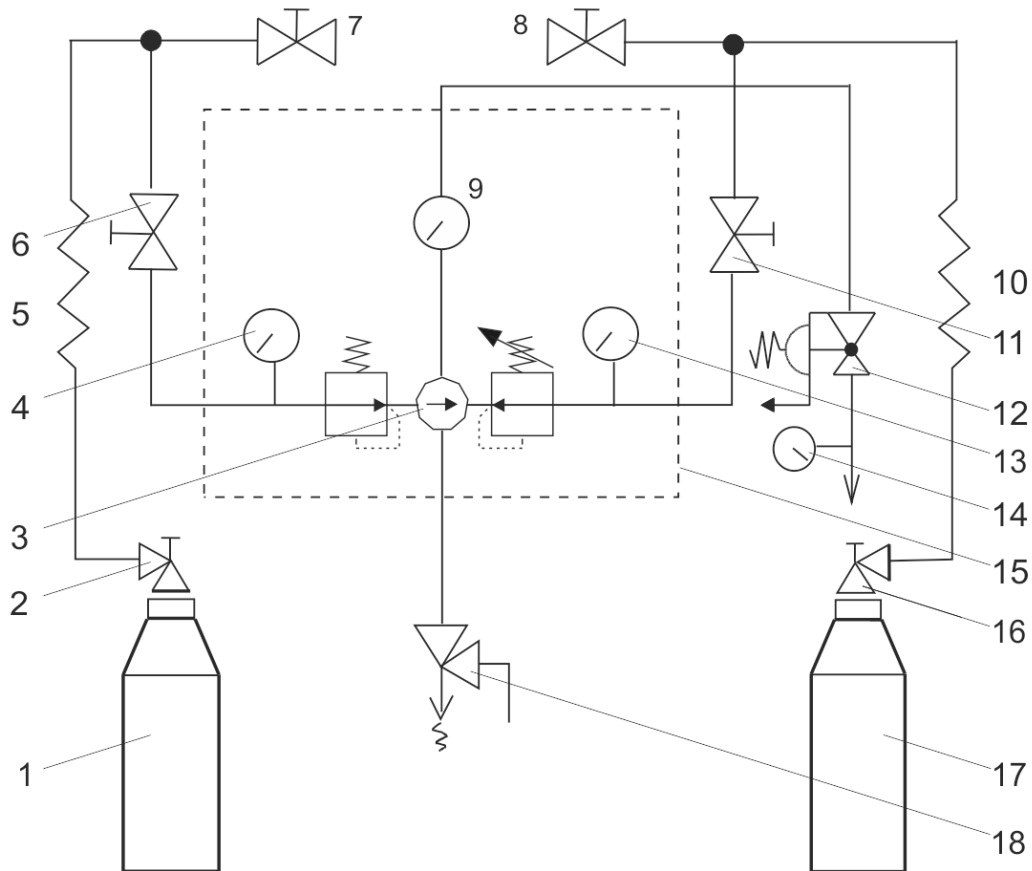

- | | | | |
|----|--|----|---|
| 1 | Carrier gas cylinder A
Helium-filled max. 200 bar | 11 | Shut-off valve 2B |
| 2 | Cylinder valve A | 12 | Pressure regulator |
| 3 | Selector switch | 13 | Contact pressure gauge |
| 4 | Contact pressure gauge | 14 | Outlet of carrier gas at 5.5 bar |
| 5 | High-pressure helix | 15 | Automatic changeover block
Changeover pressure 7-10 bar |
| 6 | Shut-off valve 2A | 16 | Cylinder valve B |
| 7 | Shut-off valve 1A | 17 | Carrier gas Cylinder B
Helium-filled max. 200 bar |
| 8 | Shut-off valve 1B | 18 | Safety relief valve with an
Opening pressure of 13 bar |
| 9 | Output pressure gauge | | |
| 10 | High-pressure helix | | |

Figure 1: Automatic switchover unit type USE-3A block circuit diagram

1.4.4 Replacing the carrier gas filter

Caution

The molecular sieve column (Module C) is very sensitive to moisture.

Therefore, an additional filter is installed at the carrier gas inlet for all measuring elements with oxygen / hydrogen measurement (*Figure 6: Gas chromatograph PGC 9300, Pos. 6*). It is a moisture filter that filters water out of the carrier gas. The filter can be obtained from RMG as spare part; the type designation is:

Gas Clean Moisture Filter (Agilent)

Note

A color indicator shows whether the filter must be replaced. Fields with corresponding colors for ORIGINAL and SATURATED are printed on the filter cap.

The filter must be changed when the display field begins to change color.

If the indicator completely changes color to SATURATED, damage to the measuring element is possible. The service department must be contacted in this case.

Caution

We urgently recommend contacting RMG customer service to replace the filter on the PGC 9300 in order to minimize the risk of damage to the measuring element.

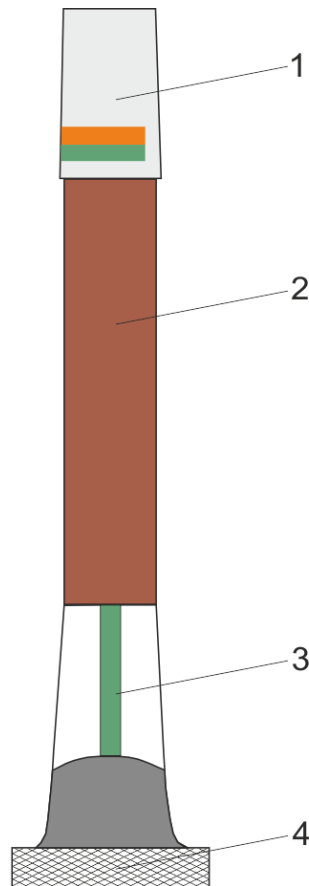

- 1 Filter cap with color codes
- 2 Filter granulate
- 3 Color indicator for moisture
- 4 Knurled screw connection

Figure 2: Molecular sieve filter

Filter replacement must take place as follows:

1. Decommission the device as specified in section 6.5 and switch off the measuring element. Observe a possible PGC timeout on the downstream corrector.
2. Loosen the knurled screw connection and unscrew the filter. Since residual pressure may still be present in the filter, hold the filter firmly with your other hand.
3. Replace O-ring seals on the filter base according to the manual accompanying the filter.
4. Slide the knurled screw connection over the new filter.
5. Remove the metal plug on the new filter.

6. Insert a new filter and turn it until it is seated in its guide.
7. Re-tighten the knurled screw connection.
8. Unscrew the compression fitting connection on the outlet of the filter base to install the filter by jetting.
9. Re-connect the carrier gas supply. Carrier gas then streams under high pressure at the loosened screw connection.
10. Flush the filter(s) for at least 24 hours in this manner.
11. Close the screw connection again under flow.
12. The screw connection and area of the knurled screw connection must be checked for leaks with a tracing device.
13. Wait at least 15 minutes until the measuring element has been flushed.

⚠ Caution

An inadequate flushing time can result in irreparable damage to the measuring element!

14. Re-commission the device as specified in 6.5.
15. Enter filter replacement in the maintenance log.

Note

The saturated filter is special waste and must be disposed of according to statutory specifications.

Appendix 3: *Pre-filter flushing unit* describes how simple replacement with reduced maintenance times can be realized with 2 filter units.

2 Quick guide

This chapter does not replace the rest of the operating manual. It only provides a brief abstract of the necessary steps to commission the device.

26

⚠ Danger

This chapter is only intended for experienced users!

It does not replace all safety instructions that are primarily listed in the first part of the manual but can also be found in the remaining chapters.

Moreover, use of this chapter “Quick guide” requires that the experienced user is familiar with all of these safety instructions and implements them when working with the device.

RMG rejects liability for any damage to the device or other connected devices if a user disregards even one of the safety notices in the overall manual because of this chapter “Quick guide”. This also applies to safety instructions to which reference was only made in this manual but were not explicitly listed.

2.1 Mechanical connection

The supply lines for connections A - M (*Figure 6: Gas chromatograph PGC 9300*) are designed as 1/8” pipelines with a compression fitting connection. Appropriate particle filters are arranged upstream from the analytical device. The lines should be stainless steel and free from soiling, grease, solvents, etc.

The gases must be connected to the process gas chromatograph in compliance with the rules for working with pure gases (VDI 3490 page 3, Dec. 1980).

The gas discharge line must have a minimum inside diameter of 4 mm. A 6 mm compression fitting connection must be provided.

Carrier gas connection

The connection of the carrier gas according to the aforementioned guidelines should take place with the ball valve closed first.

It must be ensured that a pressure of 5.5 bar is provided.

After connection, the supply lines must be flushed by opening the compression fitting connection on the inlet filters.

The power supply to the measuring unit can be re-established after the ball valve is opened and a wait time of **at least 15 min** is observed.

Monitoring of the carrier gas pressure now takes place with the internal pressure transducer and analytical computer. The pressure at the analytical computer can be read on the “Status” screen and fine adjustments can be made when checking the display value.

Connection values: 5.5 bar ($\pm 10\%$)

Measuring gas / calibration gas / reference gas

Connection of these gases must take place in the same manner as connection of the carrier gas.

The input pressure should line in the range between 1.1 – 2.5 bar.

The pressure must be identical for all three inputs. The permissible tolerance is $\pm 10\%$.

The pressure monitoring takes place with an integrated pressure transducer in a manner that is similar to that of the carrier gas. The measurements are also available at the bottom of the “Status” screen of the analytical computer. The measured input pressure at the

GC 9300 can be read for pressure equalization of the analysis gas input. If the pressure compensation takes place for measuring gas, the adjustment is also suitable for calibration gas and reference gas.

Column supply pressure and column temperature

Continuous monitoring of the pre-settings for the factory calibration is carried out by the analytical computer during operation. When the limit values are exceeded, an error message is issued, and no further analysis takes place.

Further process

The “Normal Calib.” operating mode must be selected after compensation of the input pressures. The chromatograph performs a calibration cycle.

The PGC 9300 automatically switches to “Autorun” mode after successful calibration.

Please read *chapter 4.5 Interruption of the carrier gas supply* for details about interrupting the carrier gas supply.

2.2 Electrical connection

28

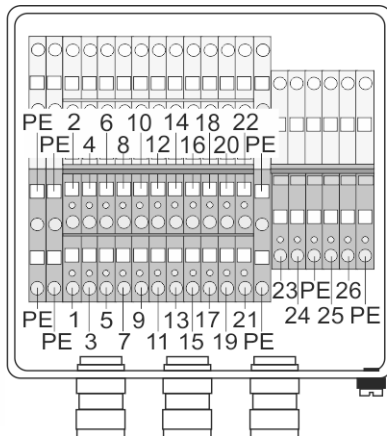

Figure 3: Electrical compartment

**Clamping ranges of cable glands
(permissible cable diameter):**

number	Inner casing	Outer casing
Ex-PGC		
5	8.7 mm	6.1 – 13.1 mm

For recommended cable types, also for grounding, refer to *chapter 4.1 Electrical connections*.

Pin assignment

Measuring element	Signal	GC 9300
1	p sample gas +	X5 / 3
2	p sample gas -	X5 / 4
3	p carrier gas 1 +	X5 / 1
4	p carrier gas 1 -	X5 / 2
5	TxD+	X18
6	TxD-	
7	RxD+	
8	RxD-	
9	p carrier gas 2 +	(X6 / 3)
10	p carrier gas 2 -	(X6 / 4)
11	int. cal. gas	X2 / 1
12	ext. cal. gas	X2 / 3
13	stream 1	X1 / 1
14	stream 2	X1 / 3
15	stream 3	X1 / 5
16	stream 4	X1 / 7
17	GND	X1 / 2, 4, 6, 8 X2 / 2, 4
23	+ 24 V heater	
24	- 24 V heater	
25	+ 24 V measuring element	
26	- 24 V measuring element	

2.3 Commissioning

Commissioning normally takes place together with the controller. For this purpose, read the manual of the GC 9300 (PGC9300_AC_manual_en).

3 Gas chromatograph PGC 9300

The **Process Gas Chromatograph PGC 9300** analyzes natural gas and biogas and determines the quantities of individual components of these gases from which the energy content, compressibility factor and other parameters can be calculated in an additional, separate evaluation unit. This other, separate evaluation unit is the GC 9300, which determines the course of the analysis and provides measurement results as an evaluation unit and control computer. The PGC 9300 is always operated together with the GC 9300.

29

3.1 Type designation

The various versions of the PGC 9300 differ depending on the application. The designation PGC 9300 is used as a collective term in this manual. If differentiation must be made between the variants, they are listed separately.

PGC 9301

This type is designed for use in “normal” natural gas. It operates with 2 column modules (A and B) and can determine the gas components nitrogen (N_2), methane (CH_4), carbon dioxide (CO_2), ethane (C_2H_6) with Column A and propane (C_3H_8), butanes (C_4H_{10}), pentanes (C_5H_{12}) and hexane together with all higher hydrocarbons with Column B.

PGC 9302

This type is designed for use in biogas. It operates with 2 column modules (A and C) and can determine the gas components methane (CH_4), carbon dioxide (CO_2), ethane (C_2H_6), propane (C_3H_8), butanes (C_4H_{10}) with Column A and hydrogen (H_2), oxygen (O_2) and nitrogen (N_2) with Column C.

PGC 9303

This type enables determination of additional gas components in “normal” natural gas.

It operates with 3 column modules (A, B and C) and can determine the gas components methane (CH_4), carbon dioxide (CO_2), ethane (C_2H_6) with Column A, propane (C_3H_8), butanes (C_4H_{10}), pentanes (C_5H_{12}) and hexanes together with all higher hydrocarbons with Column B and hydrogen (H_2), oxygen (O_2) and nitrogen (N_2) with Column C.

PGC 9304

This type enables determination of additional gas components in “normal” natural gas.

It operates with 3 column modules (A, B and C), wherein Argon is used as a carrier gas in Column C. With Columns A and B, it can determine the same gas components as the PGC 9303; with the 3rd Column C, it can also determine helium (He), hydrogen (H₂), oxygen (O₂) and nitrogen (N₂).

PGC 9305

This type PGC 9305 corresponds with the PGC 9301. For this PGC there will be a separate approval according to Russian regulations, the GOST. Differences in the GOST application are limited to the associated control and evaluation unit, the GC 9305.

The PGC 9305 is designed for use in natural gas of Russian origin. Like the PGC 9301, it works with 2 column modules (A and B) and can thus detect the quantities of the same gas components as this one (see above).

Table 1 below summarizes the properties again.

TYPE	Area of application	Channels (column modules)	Measured components *
PGC 9301	Natural gas	A (helium carrier gas) B (helium carrier gas)	N ₂ , C ₁ , CO ₂ , C ₂ C ₃ to C ₆₊
PGC 9302	Bio gas	A (helium carrier gas) C (helium carrier gas)	C ₁ , CO ₂ , C ₂ to C ₄ H ₂ , O ₂ , N ₂
PGC 9303	Natural gas extended	A (helium carrier gas) B (helium carrier gas) C (helium carrier gas)	C ₁ , CO ₂ , C ₂ C ₃ to C ₆₊ H ₂ , O ₂ , N ₂
PGC 9304	Natural gas extended, with helium measurement and increased meas. range for H ₂	A (helium carrier gas) B (helium carrier gas) C (argon carrier gas)	C ₁ , CO ₂ , C ₂ C ₃ to C ₆₊ He, H ₂ , O ₂ , N ₂
PGC 9305	Natural gas	A (helium carrier gas) B (helium carrier gas)	N ₂ , C ₁ , CO ₂ , C ₂ C ₃ to C ₆₊

* The chronological sequence of the components corresponds to the sequence of the list.

Table 1: Properties of the PGC 930X versions

3.1.1 Suitability and safety for natural gas containing H₂

In regard to safety-related aspects, the PGC9300 is approved to be used in natural gas containing hydrogen. However, this does not make sense for all versions, as the various versions can be used to detect different concentrations of hydrogen. Certified measurements are possible:

- PGC9301: not approved for gases containing hydrogen
- PGC9302: hydrogen content up to 5 mol-%
- PGC9303: hydrogen content up to 5 mol-%
- PGC9304: hydrogen content up to 20 mol-%
- PGC9305: not suitable for measuring gases containing hydrogen

3.2 Mode of operation

A gas sample is taken from the process line with a sampling probe. Filtration and pressure reduction take place in an inlet pressure regulating unit before the sample is delivered to the measuring element. An optional gas dryer can be provided.

Figure 4: Gas chromatograph block diagram shows the typical layout of the chromatograph in a block diagram.

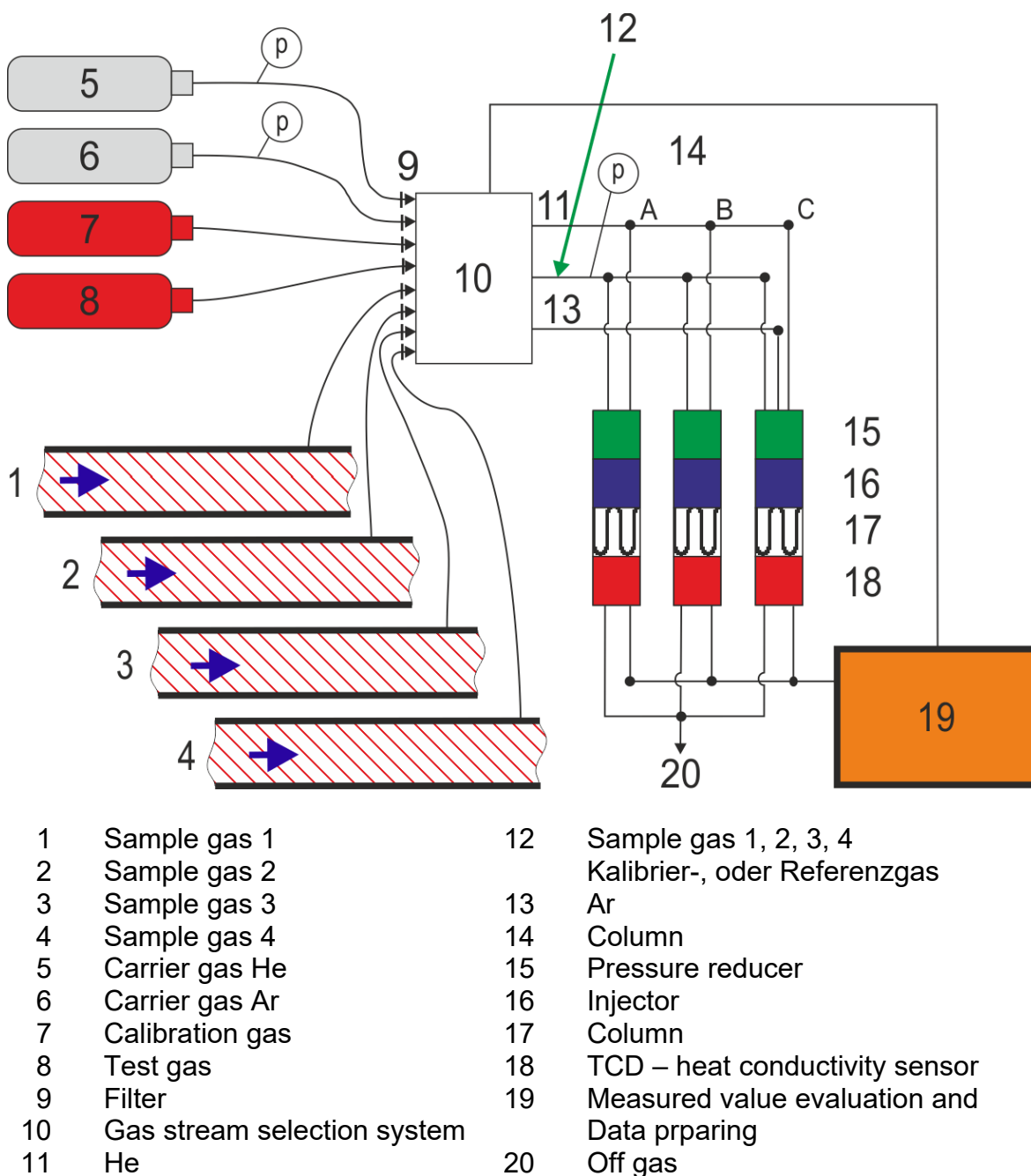

Figure 4: Gas chromatograph block diagram

One of the three inputs in the gas distribution is connected to the analyzer via valves (a “Double Block and Bleed” valve unit). A precisely defined quantity of the gas to be analyzed is supplied to the separating columns by means of the injector. This quantity is delivered through the separating columns with a carrier gas, which represents a so-called mobile phase.

33

The separation of the gas mixture is based on the interaction between the stationary phase, the coating and/or filling of columns and the components of the gas that flows past. With adsorption and a strong interaction of the individual components with the stationary phase, the individual components are selectively delayed in their passage in the stationary phase, moving at different speeds through the column. As a result, all of the components arrive at the end of the column at different times.

A thermal conductivity detector detects the emergence of the components. Therefore, a signal varying in length and height, a so-called peak, is generated for each component. The area under the signal curve is a measurement for the corresponding amount of substance.

Helium and argon are used as carrier gas in the measuring element. Two or three columns that operate in parallel are used for the separation.

The further evaluation of the area share takes place in the analytical computer GC 9300.

If the PGC 9300 is used as a multi-streamer and requires more than 2 DSfG bus connections, they can be provided with a gateway, the GC 9310. This can be seen in *Figure 5: Separation of Ex zones* to the left above the analytical computer GC 9300.

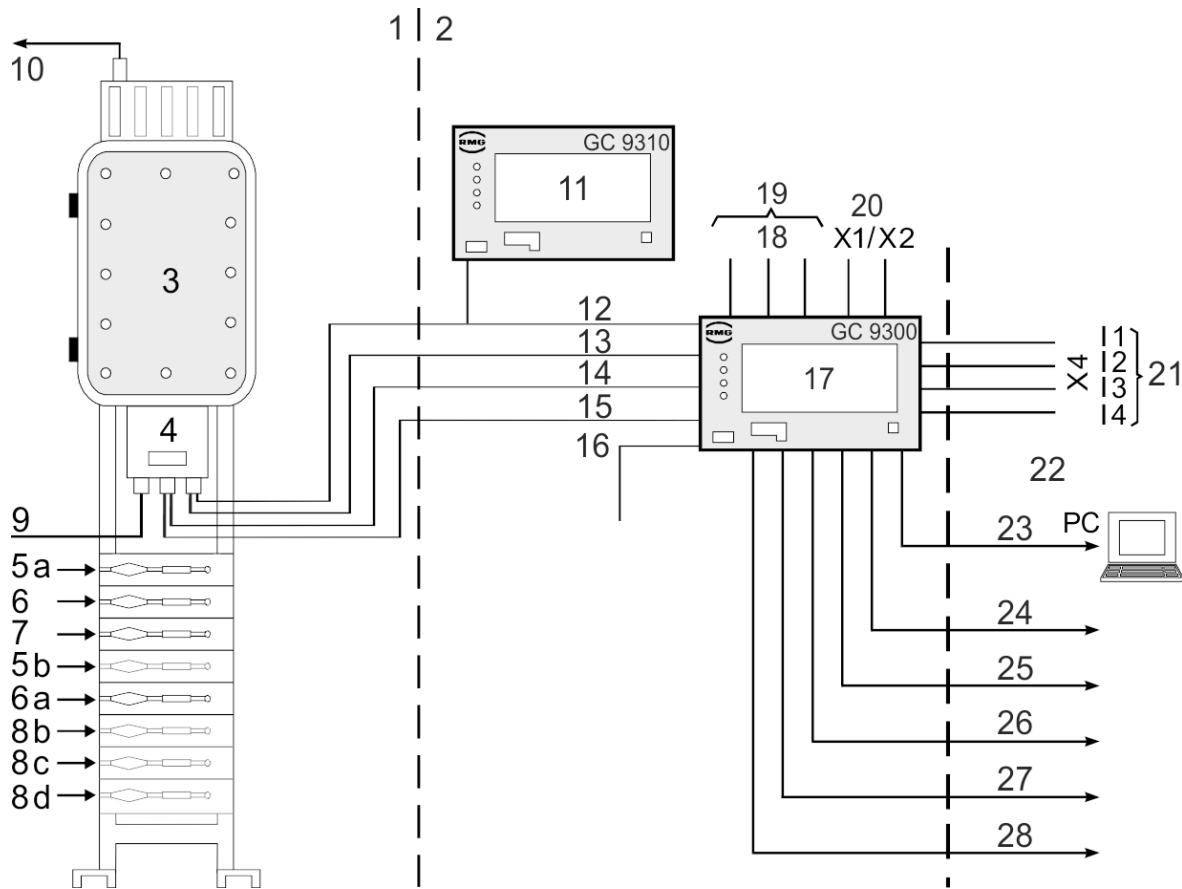

- | | | | |
|-----|--|-----|--|
| 1. | Hazardous area | 15. | X5 p sample gas (4-20 mA) |
| 2. | Non hazardous area | 16. | 230 VAC / 24 VDC |
| 3. | Measuring element | 17. | Control unit GC 9300 |
| 4. | Terminal box | 18. | E. g. calibration / measurement |
| 5. | Carrier gas inlets (1 / 2) | 19. | Contact output open collector |
| 6. | Calibration gas inlet | 20. | Relay output alarm / warning |
| 7. | Test gas inlet | 21. | Current outputs 0 / 4-20 mA |
| 8. | Sample gas inlets (max. 4) | 22. | Communication ports |
| 9. | 24 VDC | 23. | LAN2 service Ethernet (PC) |
| 10. | Vent outlet | 24. | COM1 Modbus RS 230 / 485 |
| 11. | Optional control unit GC 9310 | 25. | COM2 Wago adds I/Os RS 232/485 |
| 12. | Ethernet | 26. | COM3 DSfG/RMG bus RS230/485 |
| 13. | X1/X2 valve control LAN1 GCI (control) | 27. | COM4 DSfG/RMG bus RS230/485 |
| 14. | X5 p carrier gas (4-20 mA) | 28. | COM5: RS 232 Modbus/RMG bus
COM6/7 RS232/485 Modbus |

Figure 5: Separation of Ex zones

The analytical computer GC 9300 is the controller for the process gas chromatograph PGC 9300 and controls the analysis process in the measuring element CP 4900. In normal operation, an analysis begins as soon as the preceding analysis is finished, wherein each analysis lasts about 3-4 minutes, depending on the variant.

The series of analyses proceeds without interruption by automatic calibration. A calibration normally comprises 4 calibration gas analyses (or can be adjusted for more) and lasts about 15 minutes. The PTB approval specifies that this calibration must be repeated once per day (calibration interval = 1 day), but other intervals can be adjusted, too.

The PGC 9300 can be designed as a **single stream** unit for analysis of the gas from **one** extraction point or as a **multi-stream** unit for up to **four** extraction points.

Note

With multi-stream units, the measured gases change with each analysis in the standard setting.

If different measuring gases are measured in a multi-stream unit, the setting should be changed so that multiple measurements of the same gas take place in succession. This reduces a potential influence of mixture.

Please pay attention to legal rules if you have custody transfer measurements.

3.3 Configuration of the measuring element unit

Figure 6: Gas chromatograph PGC 9300 shows the measuring element unit in its Ex d housing. The unit can be broken down into four primary components.

- The electrical connection socket (2) with appropriate connections for the analytical computer GC 9300. (data exchange, valve control, power supply)
- A pressure-proof encapsulated unit (1) containing parts of the power supply and valve control.
- The gas distribution with carrier gas inputs A and D and inputs for the various gas streams (B, C, M1, etc.).

These inputs are connected to the chromatograph via a “Double Block and Bleed” valve assembly. The analytical computer GC 9300 controls the switching.

Two integrated pressure transducers that monitor the carrier gas and analysis gas pressure.

- The actual chromatograph is placed in a pressure-proof encapsulated housing (1).

This compact unit comprises the separating columns, heating, injectors, detectors, pressure regulation, data recording hardware and communication hardware. The housing is heated in order to maintain the necessary internal temperature.

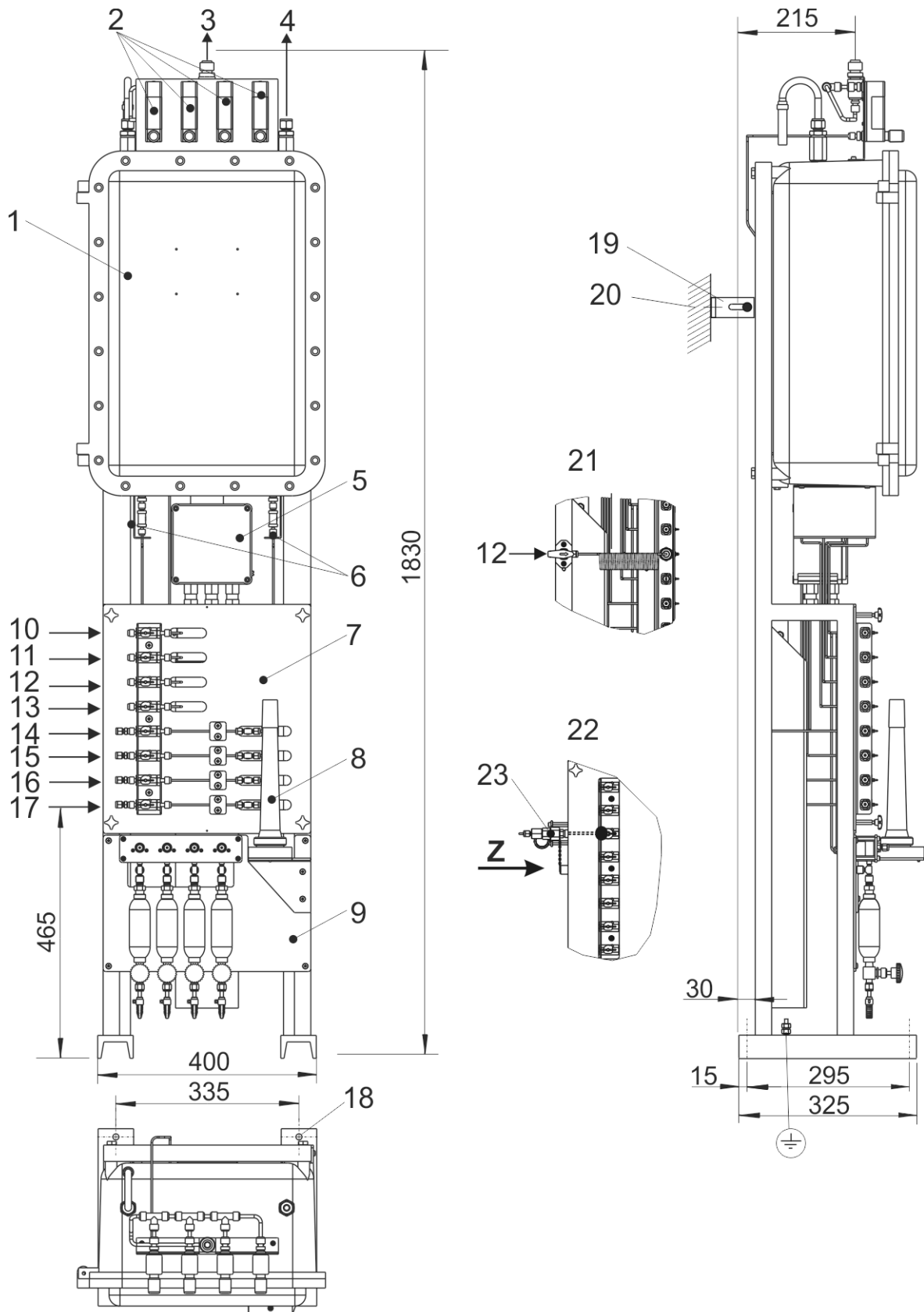

37

1. Chromatograph, Type CP4900-GC with valve control explosion-proof enclosure
2. Flow indicator for bypass, sample gas
3. Outlet pipe bypass E1
4. Outlet pipe sample gas E2
5. Ex(e) connection box
6. Inlet filter
7. Gas inlet module from the left with filter plate in pipe (basic version)
8. Inlet filter carrier gas 1 for measuring H₂-containing gases
9. Membrane filter unit with condensate collectors 75ml (hand valve) for sample gases
10. A. Gas inlet carrier gas 1 (inlet pressure 5,5 bar)
11. B. Gas inlet int. calibration gas (inlet pressure 2-3 bar)
12. C. Gas inlet ext. test gas (inlet pressure 2-3 bar)
13. D. Gas inlet carrier gas 2 (inlet pressure 5,5 bar)
14. M1 Gas inlet sample gas 1 (inlet pressure 2-3 bar)
15. M2 Gas inlet sample gas 2 (inlet pressure 2-3 bar)
16. M3 Gas inlet sample gas 3 (inlet pressure 2-3 bar)
17. M4 Gas inlet sample gas 4 (inlet pressure 2-3 bar)
18. Mounting hole $\varnothing 11 \times 4$
19. Secure the unit with the accompanying brackets at the building rear wall.
20. Rear wall
21. View Z
22. Detail front view
23. External test gas connection with quick coupling type 1215 Fabr. Minimes
24. Total weight approx. 75 kg

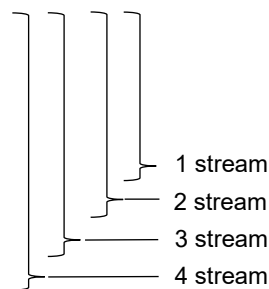

Figure 6: Gas chromatograph PGC 9300

3.4 Gas flow distribution

The purpose of the gas distribution is to connect one of the four gas streams to the analyzer and to supply the carrier gas.

In order to avoid contamination of the selected gas stream due to potential leakage of the valves, a so-called “Double Block and Bleed” arrangement of valves was selected.

Figure 7: Gas (distribution principle diagram) shows a corresponding arrangement in which Gas Stream 2 is selected. It shows that the volumes between the valves of gas streams that are not selected are vented to the atmosphere. As a result, any occurring leaks cannot contaminate the analysis gas stream.

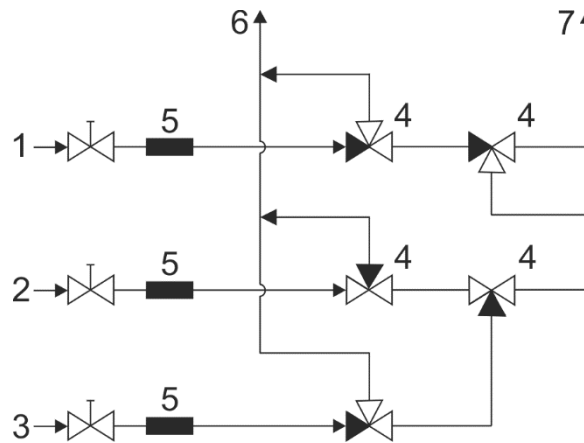

- 1. sample gas
- 2. calibration gas
- 3. test gas
- 4. safe shut off valve
- 5. gas filter
- 6. off gas
- 7. sample gas outlet

Figure 7: Gas (distribution principle diagram)

3.5 Gas chromatograph

Figure 7: Gas (distribution principle diagram) and Figure 8: Gas distribution (photo) show the layout of the analysis unit located in the pressure-proof housing (Pos. 1).

This is composed of three essential functional units for each channel:

- **Pressure regulation / valve actuation**

This unit includes pressure regulation and monitoring for the carrier gas pressure upstream from the columns and the control valves for the injector.

The setting is adjusted at the factory during the basic calibration of the device.

- **Column modules**

Each column module comprises an injector, a reference and measurement column, heat conductivity detectors, column heating, injector heating and, if applicable, a back flush unit for column C (molecular sieve column).

- **Electronic unit**

This unit consist of an analog and a digital part as well as a communication unit. Data recording and preparation, temperature regulation, pressure monitoring and communication with the main board take place here. The main board is responsible for the evaluation of the chromatogram and for the transmission of all measurement data to the analytical computer.

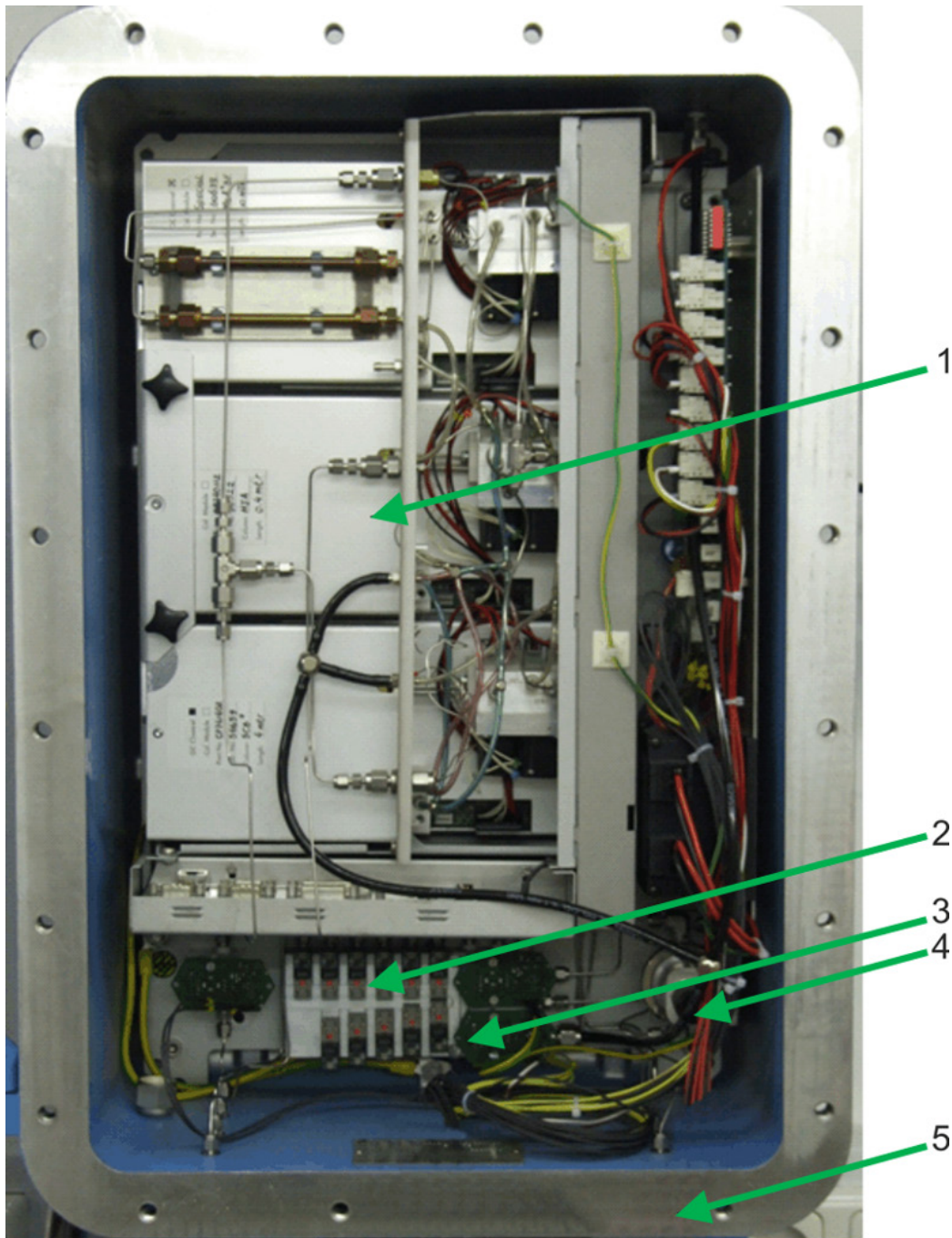

- 1 Analysis modules
- 2 Solenoid valve
- 3 Pressure regulator
- 4 Pressure transmitter
- 5 Ex d enclosure

Figure 8: Gas distribution (photo)

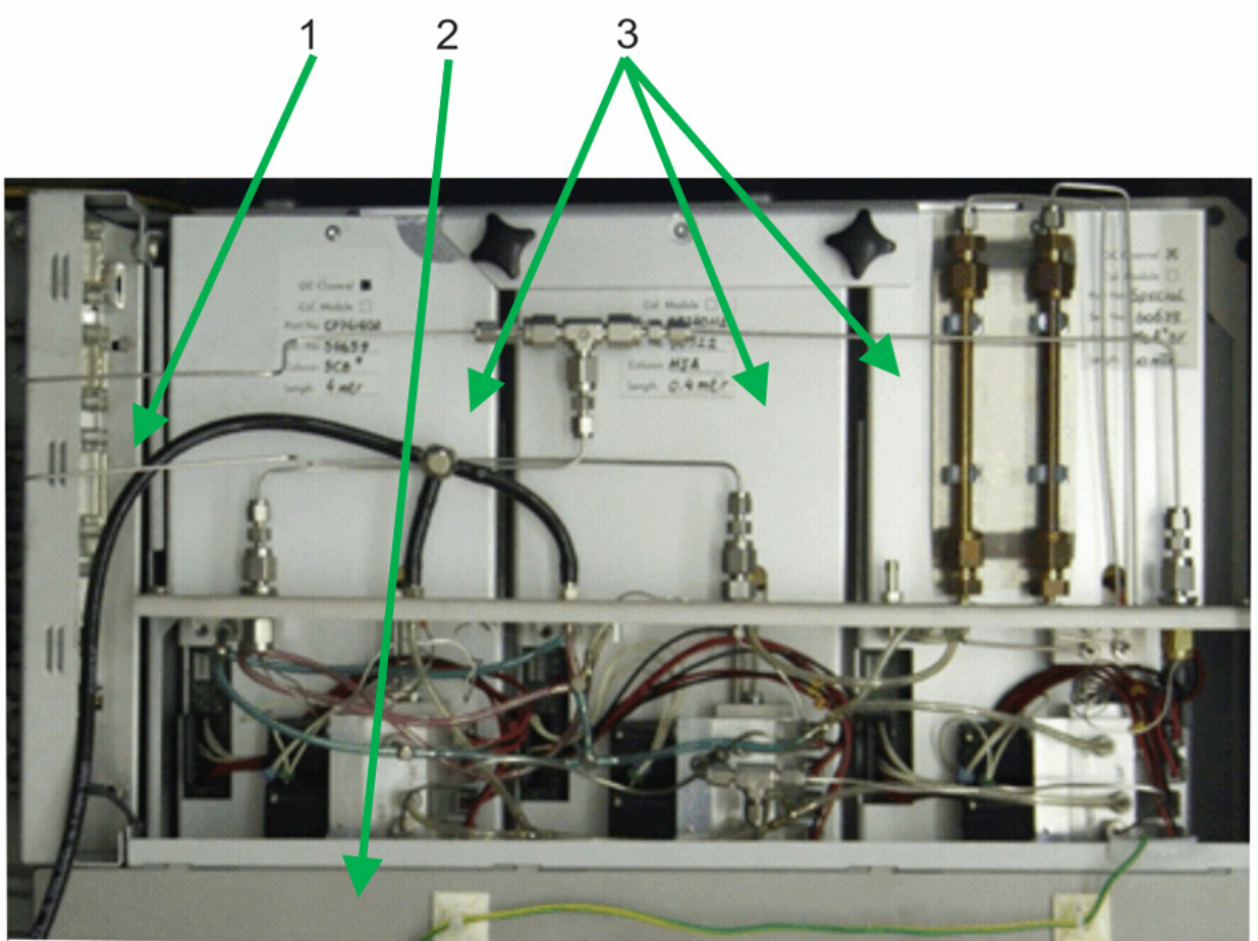

- 1 Main board
- 2 Power supply
- 3 Analysis modules

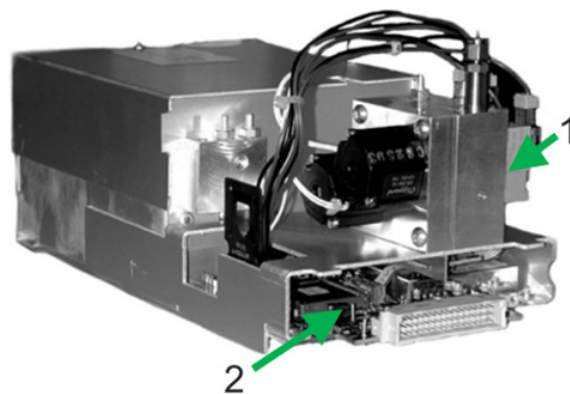

- 1 Column pressure regulation
- 2 Column electronics

Figure 9: Functional blocks

3.6 Analysis process

The following four diagrams *Figure 10: Flushing (default position)*, *Figure 11: Application of pressure*, *Figure 12: Injection* and *Figure 13: Analysis* show the basic analysis sequence. The process is only shown for one channel for the purpose of simplification.

43

- Default position

Carrier gas (green) is connected to the injector via a solenoid valve with a pressure of 5.5 bar. It applies pressure to the micro valves for the injection and gas sample, whereby they are closed (red). The pressure-regulated carrier gas flows continuously over flow resistors through the analysis and reference column.

- Flushing (Figure 10: Flushing (default position))

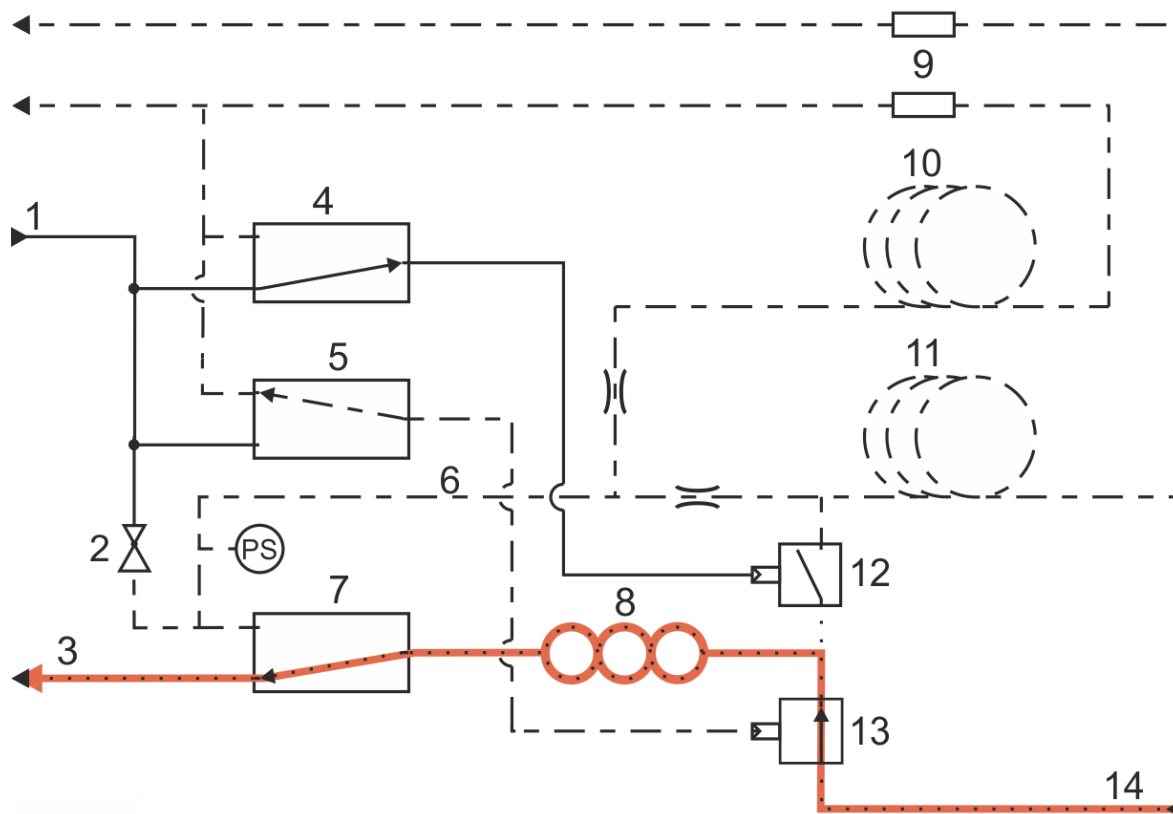

Carrier gas 5,5bar
 Carrier gas regulated
 Sample

1	Carrier gas 5,5bar	8	Sample loop
2	Pressure regulator	9	TCD
3	Sample vent	10	Reference column
4	Injection	11	Sample column
5	Sample	12	Injection
6	Carrier gas	13	Sample
7	Switch	14	Sample in

Figure 10: Flushing (default position)

The solenoid valve for the gas sample is switched to ventilation, the pressure at the micro valve is relieved and the valve opens. The gas stream flows through the sample loop. Continuous flushing that is always activated takes place at the PGC 9300.

- Application of pressure (Figure 11: Application of pressure)

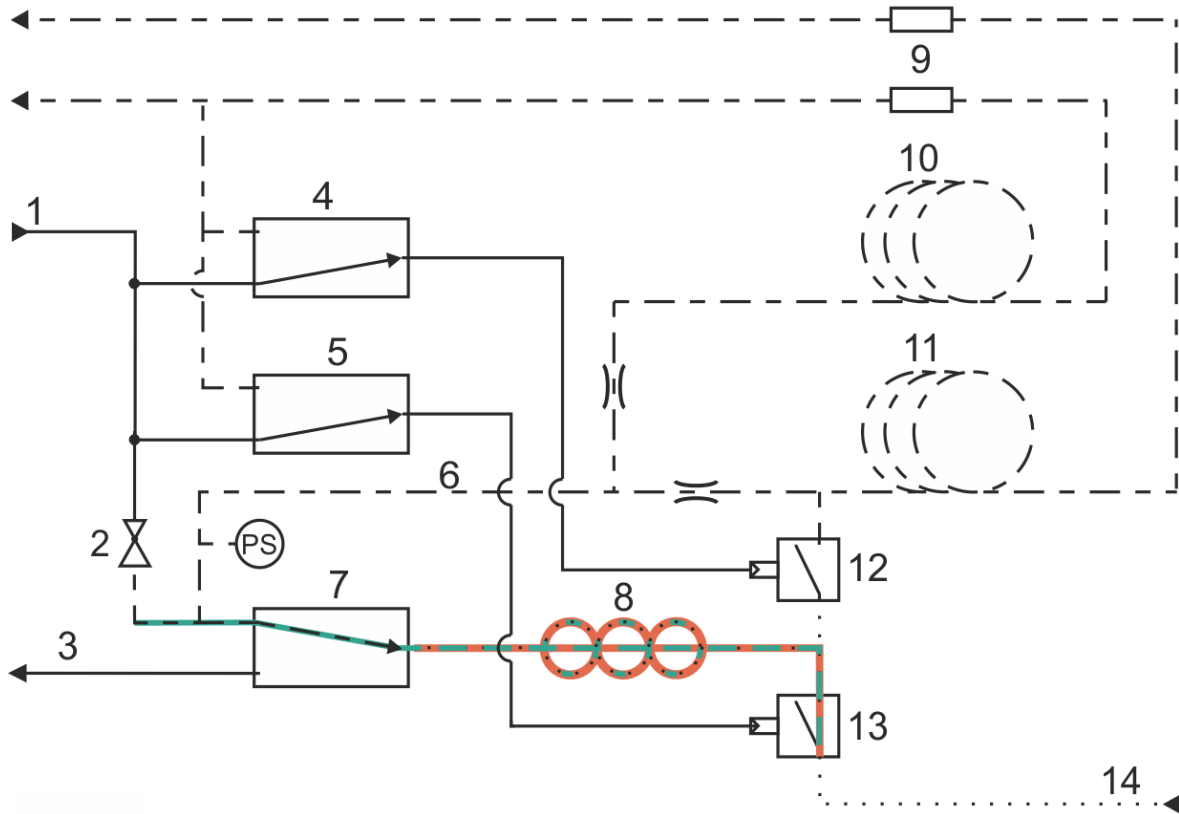

45

Carrier gas 5,5bar
 Carrier gas regulated
 Sample

- | | | | |
|---|--------------------|----|------------------|
| 1 | Carrier gas 5,5bar | 8 | Sample loop |
| 2 | Pressure regulator | 9 | TCD |
| 3 | Sample vent | 10 | Reference column |
| 4 | Injection | 11 | Sample column |
| 5 | Sample | 12 | Injection |
| 6 | Carrier gas | 13 | Sample |
| 7 | Switch | 14 | Sample in |

Figure 11: Application of pressure

The sample solenoid valve opens the micro valve for the gas sample with carrier gas and applies a control pressure of 5.5 bar. The micro solenoid valve is blocked, and a defined sample volume is enclosed in the sample loop. The switching solenoid valve regulates the pressure in the sample loop with carrier gas.

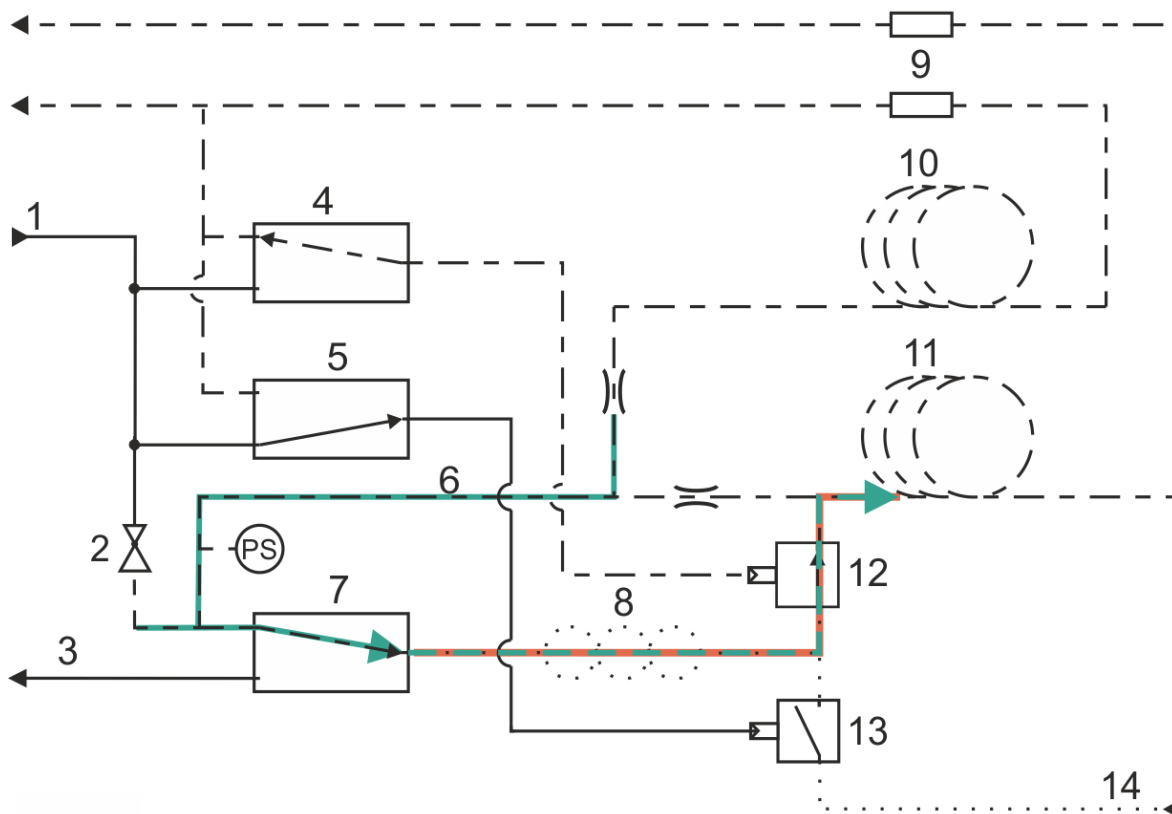
- Injection (30ms - 800ms) (Figure 12: Injection)

1	Carrier gas 5,5bar	8	Sample loop
2	Pressure regulator	9	TCD
3	Sample vent	10	Reference column
4	Injection	11	Sample column
5	Sample	12	Injection
6	Carrier gas	13	Sample
7	Switch	14	Sample in

Figure 12: Injection

The injection solenoid valve switches to ventilation and opens the micro valve for the injection. The pressure-regulated carrier gas of the switching solenoid valve drives the gas sample through the injection micro valve to the column. The reference column is not supplied with sample gas.

- Analysis (Figure 13: Analysis)

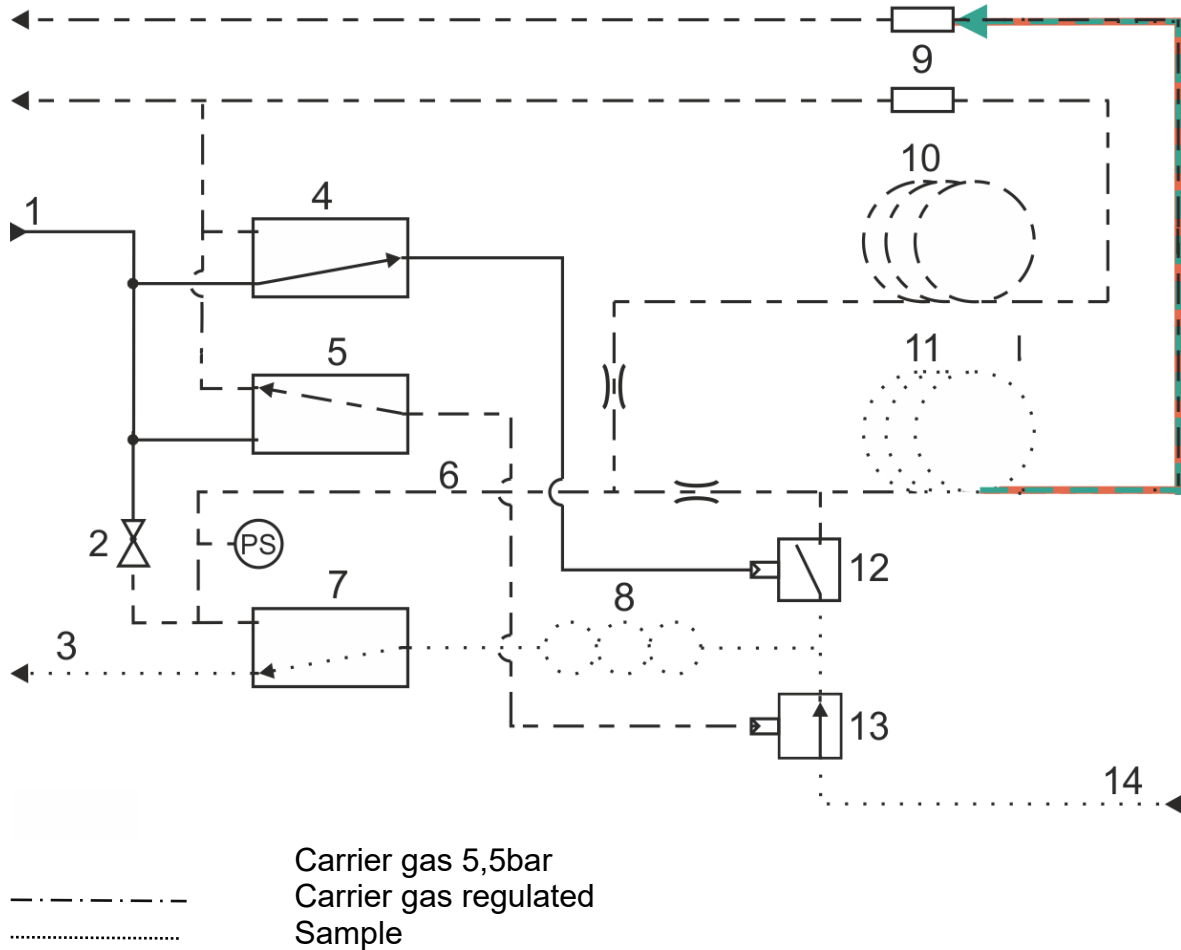

47

- | | | | |
|---|--------------------|----|------------------|
| 1 | Carrier gas 5,5bar | 8 | Sample loop |
| 2 | Pressure regulator | 9 | TCD |
| 3 | Sample vent | 10 | Reference column |
| 4 | Injection | 11 | Sample column |
| 5 | Sample | 12 | Injection |
| 6 | Carrier gas | 13 | Sample |
| 7 | Switch | 14 | Sample in |

Figure 13: Analysis

The injection solenoid valve opens and applies pressure to the injection micro valve, wherein it is closed. The gas sample is separated in the column and passes the detector.

3.7 Separating columns

As already mentioned, two or three separating columns are operated in parallel in the measuring element. The three column types in use are:

Channel A

Type: Haye Sep A

Channel B

Type: CP-Sil 5 CB

Channel C

Type: Molecular sieve

The process sequence shown in *Figure 7: Gas (distribution principle **diagram**)* applies for all channels.

3.8 Area of applicability

The PGC 9300 is normally operated in an Ex d housing in Ex Zone 1.

Safety classification:

II 2G Ex db e IIB+H₂ T5 (< 40°C) / T4 (< 60°C) Gb

3.9 Data acquisition and evaluation

The essential points of data recording and evaluation are outlined in the separate manual PGC9300_AC_manual_en. Only a few points that are relevant for the gas chromatograph are covered here.

3.9.1 Basic principles of the analysis

The basic factory setting assures good separation of the individual gas components when passing through the columns. The corresponding parameter set is identified as a **method**. Part of these settings is displayed and checked via the analytical computer. The basic physical parameters of the analysis process that influence directly the analysis result and are defined in the **method** are the following:

- Column temperatures

The column temperatures have a **direct** influence on the separating performance and analysis times. The temperature of the columns is therefore kept constant and displayed on the analytical computer.

- Running time

The running time determines the time period for which the data recording and evaluation of the TCD (thermal conductivity detector) signals take place.

- Flushing time

The flushing time defines how long the collecting loop upstream from the ejection is flushed with fresh measuring gas. It is a permanent setting from the factory calibration.

- Carrier gas pressure

Since the pneumatically controlled valves of the injector unit are actuated with carrier gas, a defined supply pressure (5.5. bar) is necessary. The adjustment is made with the input pressure regulation unit. This pressure is also monitored by the analytical computer.

Note

This pressure should not be confused with the carrier gas pressure at the columns, which is adjusted separately at the chromatograph.

- Measuring gas pressure

The measuring gas pressure is set to 1 bar at the factory. The pressure defined at the gas distribution must then be kept within a tolerance range. Measurement and monitoring also take place via the analytical computer.

3.10 Required gases and gas consumption

3.10.1 Carrier gas

The used helium and argon carrier gases must correspond to at least Class 5.0 (99.999%). The following inlet pressure must be correctly adjusted for proper function of the measuring element:

$$p_T = 5.5 \text{ bar } (\pm 10\%)$$

Pressure monitoring takes place with a pressure transducer arranged in the gas distribution. The analytical computer monitors the output signal of the pressure transducer.

The total carrier gas consumption varies as follows depending on the column pressure and variant:

$$Q_T = 0.4 \text{ NI/h} - 1.2 \text{ NI/h}$$

Note

Since helium, in particular, escapes through the smallest leaks, careful sealing and inspection of the system is very important.

3.10.2 Calibration gas

The following composition is used for the internal calibration gas:

Component	Concentration (mol%)			
	Natural gas (9301) (Type 11D)	Biogas (9302) (Type 9M)	Natural gas extended (9303, 9304) (Type 12M)	Natural gas (9305) (Type GOST)
Nitrogen	4.00	4.00	4.00	
Methane	88.90	89.00	87.45	
Carbon dioxide	1.50	2.50	1.50	
Ethane	4.00	2.50	4.00	
Propane	1.00	1.00	1.00	
Iso-butane	0.20	0.20	0.20	
n-butane	0.20	0.20	0.20	
neo-pentane	0.05	0.00	0.00	
iso-pentane	0.05	0.00	0.05	
n-pentane	0.05	0.00	0.05	
n-hexane	0.05	0.00	0.05	
Oxygen	0.00	0.40	0.50	
Hydrogen	0.00	0.20	1.00	

Kundenspezifisch/
customer specific

Note

Calibration gases must never cool down below the permissible minimum temperature specified on the corresponding certificate.

The usability of calibration gases is subject to a time limit; the expiration date is also specified on the certificate.

51

The inlet pressure is specified as:

$$p_e = 1.0 \text{ bar (internal)}$$

It must be specified before the basic calibration. Changes at a later time are not permitted. The permissible deviations during operation are:

$$dp_e = \pm 10\%$$

Permanent consumption of gas takes place during the entire calibration time. With a supply pressure of $p_e = 1.0$ bar, there is an overall flow rate of:

$$Q = 3 \text{ NI/h} - 5 \text{ NI/h}$$

3.10.3 Sample gas

⚠ Caution

The probe to be analyzed must be in a gaseous aggregate state and dry. Liquid components and other impurities are not permitted.

The values specified under 3.10.1 and 3.10.2 apply for the inlet pressure and gas consumption. The working range of the modules is within the following limit values:

Component	Concentration (mol%)				
	Officially calibrated metering				GOST measurement
	PGC	9301	9302	9303	9304
Nitrogen	0 - 20	0 - 20	0 - 20	0 - 25	
Methane	65 - 100	70 - 100	65 - 100	55 - 100	
Carbon dioxide	0 - 12	0 - 8	0 - 10	0 - 12	
Ethane	0 - 14	0 - 15	0 - 15	0 - 15	
Propane	0 - 5.5	0 - 9	0 - 9	0 - 9	
Iso-butane	0 - 4	0 - 4	0 - 4	0 - 4	
n-butane	0 - 4*2 // 0..-..0.4	0 - 4	0 - 4	0 - 4	
neo-pentane	for n-butane*3//0-0.08	-	for n-butane*2	for n-butane*2	
iso-pentane	0 - 0.3	-	0 - 0.15	0 - 0.3	
n-pentane	0 - 0.3	-	0 - 0.15	0 - 0.3	
C6+	0 - 0.3	-	0 - 0.3	0 - 0.3	
Oxygen	-	0 - 5	0 - 5	0 - 5	
Hydrogen	-	0 - 5	0 - 5	0 - 20	
Helium	-	-	-	0 - 1	

Kundenspezifisch/
customer specific

*1 In general, the measuring ranges will not match with that of PGC 9301.

*2 There are two calibrations for the PGC 9301 that are approved by the calibration authorities

- neo-pentane is reported with n-butane as a total for n-butane 0 - 4 mol%.
- neo-pentane is shown separately for the measuring range for n-butane 0 - 0.4 mol%.

*3 neo-pentane is shown as total with n-butane.

The oxygen is recognized and shown together with nitrogen without Column C.
The limit values are monitored by the analytical computer.

Note

The limit values on the type plate apply in calibrated operation.

4 Connection and commissioning

4.1 Electrical connections

⚠ Caution

The power supply of the measuring element must not be connected until the carrier gas flow has been connected and applied for at least 15 minutes!

53

The electrical connections must be made as specified in the accompanying circuit documents for both the analytical computer and the measuring element. The following connection assignment applies.

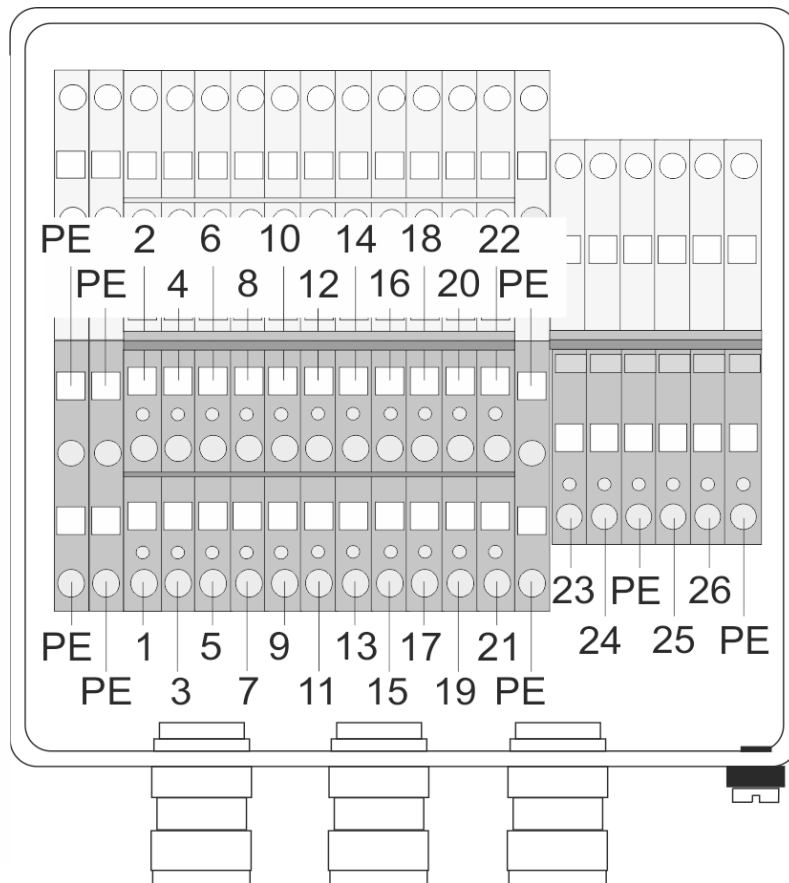

Figure 14: Connection terminal

Pin assignment

Measuring element	Signal	GC 9300	Recommended cable type
1	p sample gas +	X5 / 3	
2	p sample gas -	X5 / 4	RE-2Y(St) Yv BK
3	p carrier gas 1 +	X5 / 1	2 x 2 x 0.75 mm ²
4	p carrier gas 1 -	X5 / 2	(for PGC 9304, see below)
5	TxD+	X18	Herkulat, 600 A S/FTP 4 x 2 AWG23
6	TxD-		
7	RxD+		
8	RxD-		
9	p carrier gas 2 +	(X6 / 3)	RE-2Y(St) Yv BK 4 x 2 x 0.75 mm ²
10	p carrier gas 2 -	(X6 / 4)	For PGC 9304 (Carrier Gas 2)
11	int. cal.gas	X2 / 1	
12	ext. Cal.gas	X2 / 3	RE-2Y(St) Yv BK
13	stream 1	X1 / 1	4 x 2 x 0.75 mm ²
14	stream 2	X1 / 3	
15	stream 3	X1 / 5	
16	stream 4	X1 / 7	
17	GND	X1 / 2, 4, 6, 8 X2 / 2, 4	
23	+ 24 V Heater		NY-Y-J
24	-24 V Heater		3G 2.5 mm ²
25	+ 24 V Measuring element		NY-Y-J
26	- 24 V Measuring element		3G 2.5 mm ²

The cable type NY-Y-J 3G 4 mm² should be used for the power supply (23-26) for distances greater than 50 m between the control cabinet and PGC.

Clamping ranges of cable glands (permissible cable diameter):

number	Inner casing	Outer casing
Ex-PGC		
5	8.7 mm	6.1 – 13.1 mm

Note

Some parameters for specifications have to be adjusted after switching the analytical computer on for the first time.

These values must be checked and changed as necessary (refer to the manual for the analytical computer GC 9300)!

The changed values are saved and then remain available after the computer has been shut down.

4.1.1 Grounding

Most grounding is carried out at the factory and is therefore not described further. However, grounding by the customer must also be carried out; the entire rack must be grounded.

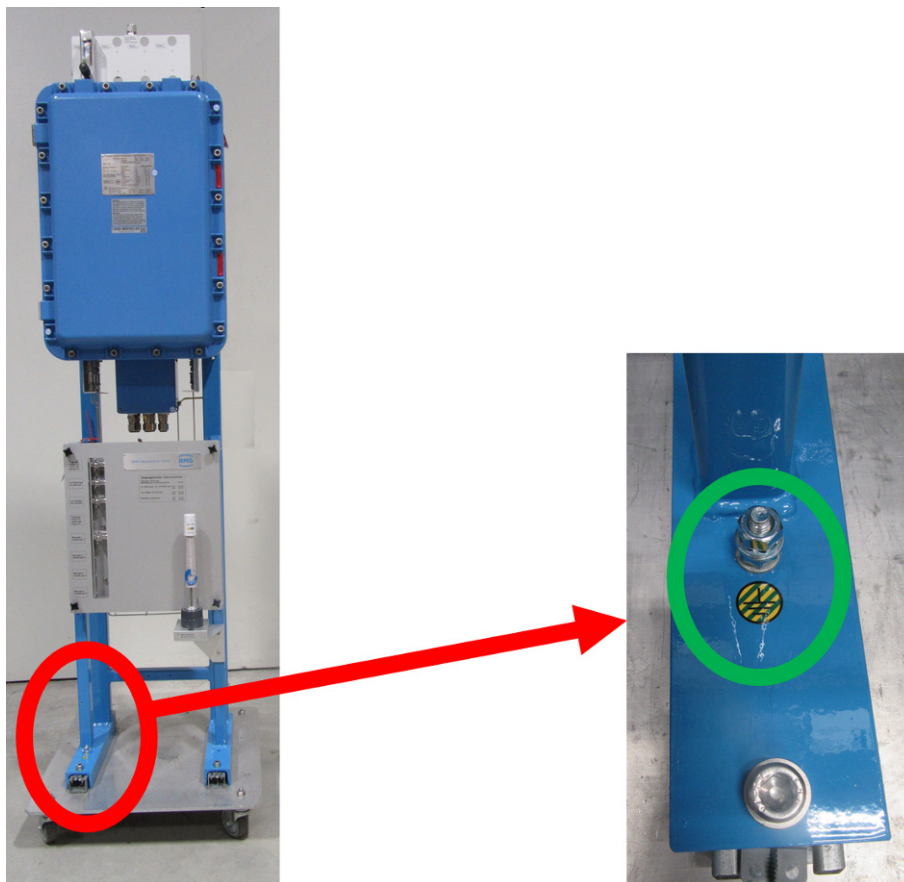

Figure 15: Grounding

Note

Please ground the screw in the green marked area.

The thickness of the earthing cable should be at least 4 mm².

56

4.2 Gas connections

The supply lines for connections A - M (*Figure 5: Separation of Ex zones*) are designed as 1/8" pipelines with a compression fitting connection. Appropriate particle filters are arranged upstream from the analytical device. The lines should be stainless steel and free from soiling, grease, solvents, etc.

Note

In order to prevent contamination with dirt or environmental air, the supply lines must be gas-tight in the relevant pressure range.

If it is necessary to seal threads or screw connections, only use Teflon tape for this purpose.

(Of course, this does not apply for compression fittings!)

Avoid using liquid leak detecting agents.

The tightness of all connections is extremely important for a proper analysis.

The gases must be connected to the process gas chromatograph in compliance with the rules for working with pure gases (VDI 3490 page 3, Dec. 1980).

Note

It must be ensured prior to commissioning that the gases that are used correspond to the specified requirements.

The gas discharge line must have a minimum inside diameter of 4 mm. A 6 mm compression fitting connection must be provided.

⚠ Caution
<p>No additional devices may be connected to the line.</p> <p>The exhaust pipes of the measuring device must be separated and must not be put together!</p>

⚠ Danger
<p>An overpressure must not develop in the line.</p>

4.2.1 Carrier gas connection

Note
<p>The connection of the carrier gas according to the aforementioned guidelines should take place with the ball valve closed first.</p> <p>It must be ensured that a pressure of 5.5 bar is provided.</p> <p>After connection, the supply lines must be flushed by opening the compression fitting connection on the inlet filters.</p> <p>The power supply to the measuring unit can be re-established after the ball valve is opened and a wait time of at least 15 min is observed.</p>

Monitoring of the carrier gas pressure now takes place with the internal pressure transducer and analytical computer. The pressure at the analytical computer can be read on the “Status” screen and fine adjustments can be made when checking the display value.

Connection values: 5.5 bar (± 10%)

4.2.2 Sample gas / calibration gas / reference gas connection

Connection of these gases must take place in the same manner as connection of the carrier gas. In the process, the input pressure should line in the range between **1.1 – 2.5 bar**. The specification of a specific inlet pressure must take place **before**

the **basic calibration** of the device. If this pressure has been defined, changes are no longer permitted.

Note

The pressure must be identical for all three inputs. The permissible tolerance is $\pm 10\%$.

58

The pressure monitoring takes place with an integrated pressure transducer in a manner that is similar to that of the carrier gas. The measurements are also available at the bottom of the "Status" screen of the analytical computer. The measured input pressure at the GC 9300 can be read for pressure equalization of the analysis gas input. If the pressure compensation takes place for measuring gas, the adjustment is also suitable for calibration gas and reference gas.

4.3 Column supply pressure and column temperature

The column temperatures and carrier gas pressure at the injectors can be defined with the factory calibration of the device.

Continuous monitoring of the values is carried out by the analytical computer during operation. When the permissible limit values are exceeded, an error message is issued, and no further analysis takes place. The corresponding limit values can be seen on the analytical computer in the "Details" screen under measuring unit/analysis pressure/max. deviation and/or measuring element/carrier gas I/max. deviation (GC 9300 manual).

4.4 Further process

The "Normal Calib." operating mode must be selected after compensation of the input pressures according to the description above. The chromatograph will now conduct a calibration cycle.

If the first calibration is faulty, the PGC 9300 will start another calibration after a few minutes. If the second calibration is also faulty, the PGC 9300 automatically switches to the operating mode "Stop".

The PGC 9300 automatically switches to “Autorun” mode after successful calibration.

4.5 Interruption of the carrier gas supply

With an interruption of the carrier gas supply, e.g. during a change of the carrier gas cylinder without use of the switchover unit, the analysis must be interrupted by selecting the mode “STOP” on the analytical computer.

If the analytical computer has “STOP” status, – in other words, the running analysis was ended – all inlet valves on the gas distribution (*Figure 6: Gas chromatograph PGC 9300 / A - M*) are closed. If the carrier gas pressure at the measuring element has dropped enough, the software automatically lowers the column temperatures to 30°C and switches off the detectors. This is recognizable by the setpoint temperatures on the Status screen on the controller.

Once the setpoint temperatures have changes, the measuring element can be switched off. If the supply with carrier gas has been re-connected (regular flushing of pressure regulators and supply lines!), the inlet pressure should be checked (inlet pressure regulating unit).

After the inlet valve (*Figure 6: Gas chromatograph PGC 9300 / A and D*) has been opened, a further check can take place on the analytical computer (“Status” screen). The device must remain in this state **for at least 15 min**.

Now the power supply for the measuring element can be switched on again. After a wait time of an **additional 15 min**, the remaining inlet valves (*Figure 6: Gas chromatograph PGC 9300 / B, C and M*) can be opened again. The analytical computer must now be switched to the mode “Normal calib.”.

After successful calibration, the analytical computer automatically switches over to “Autorun” mode.

Note

If the power supply was disconnected for more than 0.5 h, an additional calibration should take place after about 1-2 h.

If error messages appear on the initial calibration or at the beginning of the analysis, it may be due to the remains of foreign gases.

These messages should be acknowledged within 2 h after operation.

If the measuring element should be decommissioned for an extended period, the device should be shut down. For this purpose, the measuring element must first be disconnected from the power supply as described above. If possible, the supply of the measuring element with carrier gas should continue for the duration of the downtime by opening the inlet valve for helium (A) and if applicable argon (D) after the measuring element has been shut down. If this is not possible, the exhaust gas line should be provided with a gas-tight seal with a dummy plug after shutting down the measuring element and interrupting the carrier gas supply until the time of re-commissioning.

Alternatively, the PGC 9300 can be prepared for a longer period of storage by flushing the device with nitrogen (5.0) at 3 bar for at least 15 minutes at all inlets. Then all inlet valves must be closed and then the two outflow lines must also be provided with a gas-tight seal with dummy plugs.

⚠ Caution

The discharge lines must be re-connected after re-commissioning and the device must be flushed with the carrier gas (helium and/or argon) for at least 15 minutes before the device is switched on again.

For the PGC 9302 and PGC 9303, the process must be carried out in the same manner, but with nitrogen (N₂) instead of the carrier gas.

For this purpose, please also observe *chapter 4.2.1 Carrier gas connection*.

Note

Chapter 1.2.10 Storage provides further information about storage of the PGC 9300.

Re-commissioning must then take place according to the process above.

⚠ Caution

The dummy plugs must be removed first. Otherwise an excessively high pressure is established in the measuring element!

Disregarding this can result in irreparable damage to the measuring element!

The versions with a Column C also include a replaceable filter cartridge between the shut-off valve and housing feedthrough for the carrier gas line.

5 Operating modes of the device

61

The measuring element operating modes can be adjusted in the “Details” screen of the analytical computer under GC9300 mode/operating mode (refer to the manual for GC 9300: PGC9300_AC_manual_12_en).

5.1 Automatic operation

Automatic analysis mode (“autorun”) is the normal operating mode of the measuring element. A cyclical sampling and analysis of the measuring gas are carried out. This process is only interrupted by the automatic recalibration (“Details” screen under calibration parameters).

5.2 Stop mode

This mode is activated in order to switch off analysis mode. After the current analysis is finished, the continuous operation is interrupted.

5.3 Normal calibration

A switchover to the calibration gas inlet and implementation of a calibration cycle according to the defined data (“Details” screen under calibration parameters) are carried out. After the calibration is finished, the valves are switched back to the measuring gas inlet and a continuous analysis of the measuring gas is conducted. The timing of the next automatic recalibration is not changed.

5.4 Reference gas analysis

The reference gas inlet (for test gas) is switched on and a continuous analysis is conducted. However, the maximum number of analyses is the number that can be specified at the GC 9300 controller under the path “GC9300 mode/ref. gas/maximum number”. Then an automatic switch to “Autorun” occurs.

After re-calibration, the external calibration gas is analyzed via the reference gas inlet. This is a normal analysis and the correction factors from the last automatic or manual calibration remain unchanged.

5.5 Basic calibration

A calibration cycle is triggered, and the determined factors are stored in the computer as response factors of the basic calibration together with the retention times. After the calibration cycle, the system switches to

“AUTORUN”

mode.

Appendix 1: Technical data

Power supply:	21V DC - 27V DC	63
Power consumption:	Measuring element: max. 186 W	
Housing heating	100 W Typical: 178 W	
Start-up current: in normal operation	10 A during the first 3 minutes, approx. 1.5 A	
Air humidity:	0% - 95% relative air humidity Condensation not permitted.	
Safety classification:	 II 2G Ex db e IIB+H ₂ T5 (< 40°C) / T4 (< 60°C) Gb	

Note

The PTB approval demands an ambient temperature between +5 and +40°C for the measurement. These temperature limits also apply to the calibration gas supply lines and the location of the calibration gas cylinder.

The device must be protected against direct weather influences.

Dimensions: see *Figure 6: Gas chromatograph PGC 9300*

Weight: 75 kg

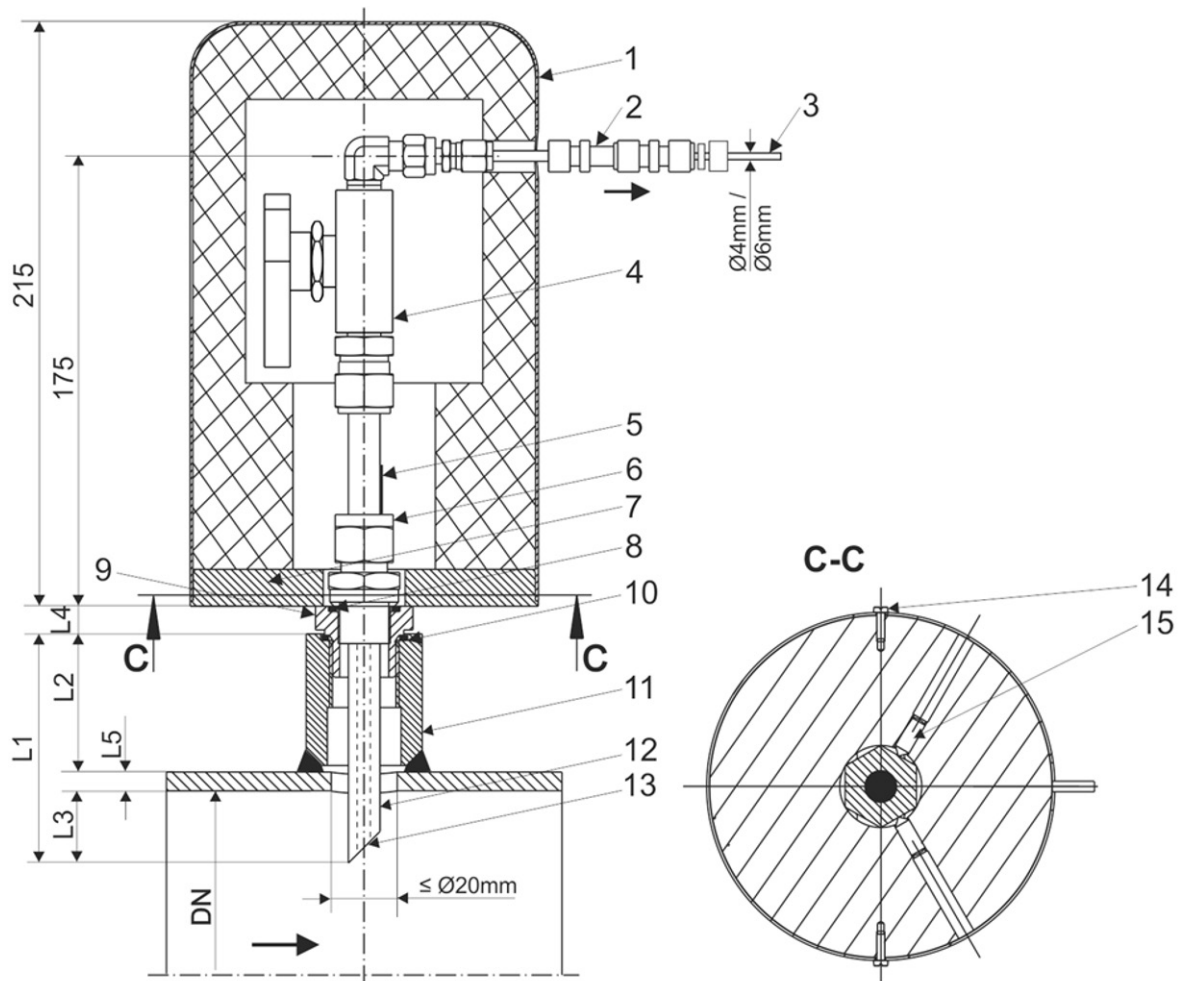

- | | |
|---|--|
| <ul style="list-style-type: none"> 1 Cover made of aluminium isolated with baseplate (option) 2 Isolated screw connection for electrical isolation(option) 3 Connection pipe 4 Ball valve 5 Red mark 6 Pipe fitting G1/2" 7 Baseplate 8 Gasket according to DIN7603 made of aluminium for connection thread G1/2" 9 Adapter for weldolet G3/4" and G1" 10 Gasket according to DIN7603 made of aluminium for adapter G3/4" und G1" | <ul style="list-style-type: none"> 11 Weldolet G1/2", G3/4" or G1" with screw hole DIN 3852-2 form X or Y. Provided by customer. 12 Probe tube (pipe dia. Ø12 x 4) 13 The chamfer of the pipe must stand against the direction of the flow. Adjustment of the pipe at assembling in conformity with the position of the mark. 14 Capstan head screw with facility for head-sealing (option, only with cover) 15 Headless srew with point to attach the baseplate to the hexagon nut (option, only with cover) |
|---|--|

- | | | |
|----------------------|------------------------|-----------------------------|
| L1 Probe tube length | L2 Welolet height | L3 Engaged length (Pos. 12) |
| L4 Adapter height | L5 Pipe wall thickness | |

Figure 16: Sampling probe Type PES50S

Technical Description

Operating pressure 150 bar max. at an operating temperature -40°C to +93°C.
Other operating temperatures to request.

 65

All probe components are made of stainless steel.
Screw connections and stopcocks are designed for Swagelok couplings.

We recommend using a weldolet G1/2" thread. Therefore, the adapter (Pos. 9) is not necessary.

Recommended weldolet height: L2=50mm
 L4 with 1/2" weldolet thread = 0mm
 L4 with 3/4" weldolet thread = 25mm
 L4 with 1" weldolet thread = 11mm

Recommended engaged length L3 at:
 (DN50-DN100) L3=1/3DN
 (DN150-DN600) L3=1/3DN, (50mm min.)

Make sure that the hole in the piping is centrally adjusted with the pipe section and the ball valve and it has a minimum diameter of 20mm.

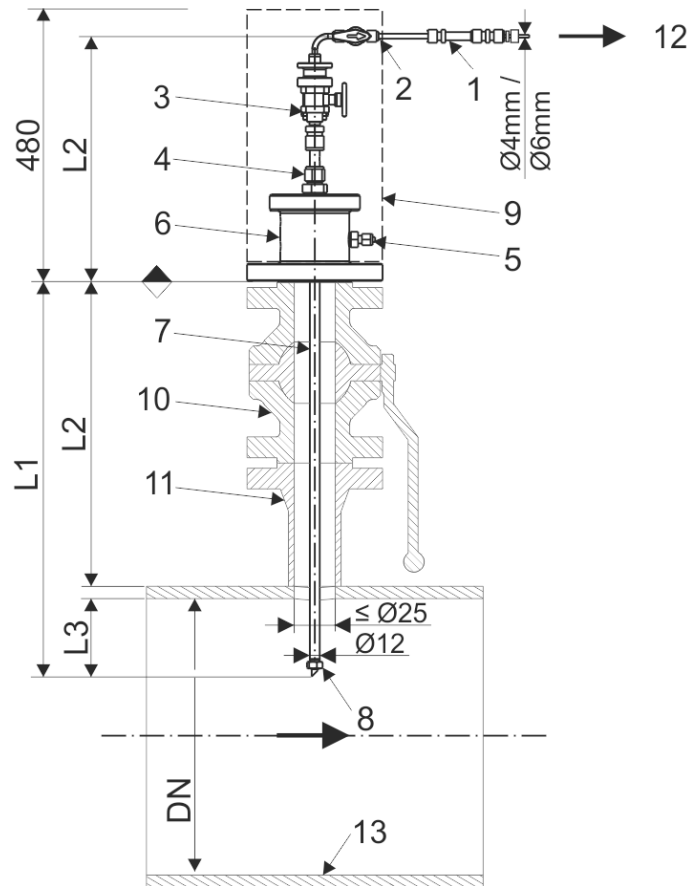

1. Isolated screw connection for electrical isolation (Option)
2. Ball Valve
3. Ball Valve with back-up ring for extending/ retracting tool
4. Straight-way screw connection
5. Bleed valve
6. Flanged-end connection head
7. Probe tube, dia. 12mm
8. Locking device (M10 nut)
9. Stainless steel cover (Option)
10. Ball valve (to be provided by customer)
11. Weldolet (to be provided by customer)
12. Sample outlet
13. Gas pipe

Figure 17: Sampling probe Type PES 02-R

Technical Description

Operating pressure (PN) 100 bar max.
 Operating temperature -28C°/+65C°

All probe components are made of stainless steel.

O-rings are made of 72 NBR 872.

Screw connections and stopcocks are designed for Swagelok couplings.

The connection head can be designed according to ASME B16.5:

ANSI flange 2":

ANSI 150RF, ANSI 150RTJ, ANSI 300RF, ANSI 300RTJ

ANSI 600RF, ANSI 600RTJ

For the specification of the probe size the exact engaged length of L1 is needed.
 (L1 = L2 + pipe wall thickness + L3) The length of L1 can be chosen between 330 to 430mm, 430 to 530mm or between 585 to 685mm. The recommended engaged length is L3=1/3DN, (50mm min.)

The probe height of L4 can vary between 300 to 400mm depending on the adjusted engaged length of L1.

Weldolet and ball valve between the probe and the ball valve are not included in the delivery.

Make sure that the hole in the piping is centrally adjusted with the pipe section and the ball valve and it has a minimum diameter of 25mm.

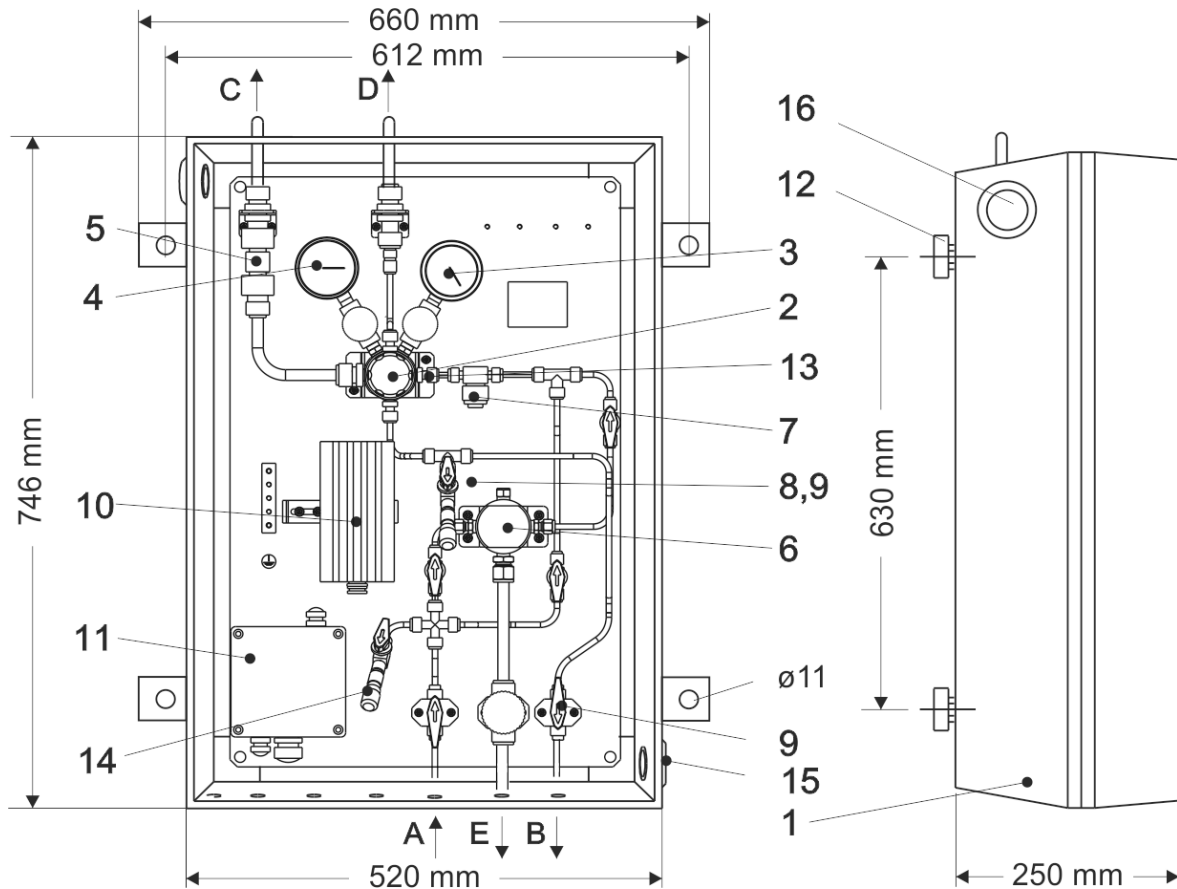

- 1) Isolation cabinet with window
- 2) Pressure reducer
Inlet-pressure max. 100 bar
Outlet-pressure 0,14-7 bar
- 3) Pressure gauge; selectable 0-160,
0-100, 0-40 bar
- 4) Pressure gauge; selectable *0-6,
0-10 bar
- 5) Relief valve with 3 bar opening
pressure
- 7) Sintered metal filter
- 8) Test port -low pressure area
(minimess-coupling type 1215)
- 9) Shut off valve
- 10) Heating (ex) 100W with integrated
thermostat in connecting cable-
frost free down to -25°C
(fixed value temperature 30°C)
- 11) Ex(e)(i)-connection box for pos.-no. 10,
4 and heating-sample gas line
- 12) Holder for wall installation
- 13) Integrated restriction $\varnothing 0,4\text{mm}$

Options:

- 6) coalescer (option)
- 14) test port with shut off valve
(minimess-coupling type 1215)
- 4) with contact gauge (adjustable)

- A. gas inlet
- B. gas outlet
- C. vent line of relief valve
- D. vent line of pressure reducer
- E. outlet condensate

Standard pipe for connections A, B:

4 mm pipe

Option: 1/8", 6 mm pipe

12mm pipe for connections C, D, E; all tube fit-
tings and connections in swagelok system.

Tube and connections material: stainless steel.

weight total 30 kg.

Figure 18: Pressure Reducing Unit Type DRS200

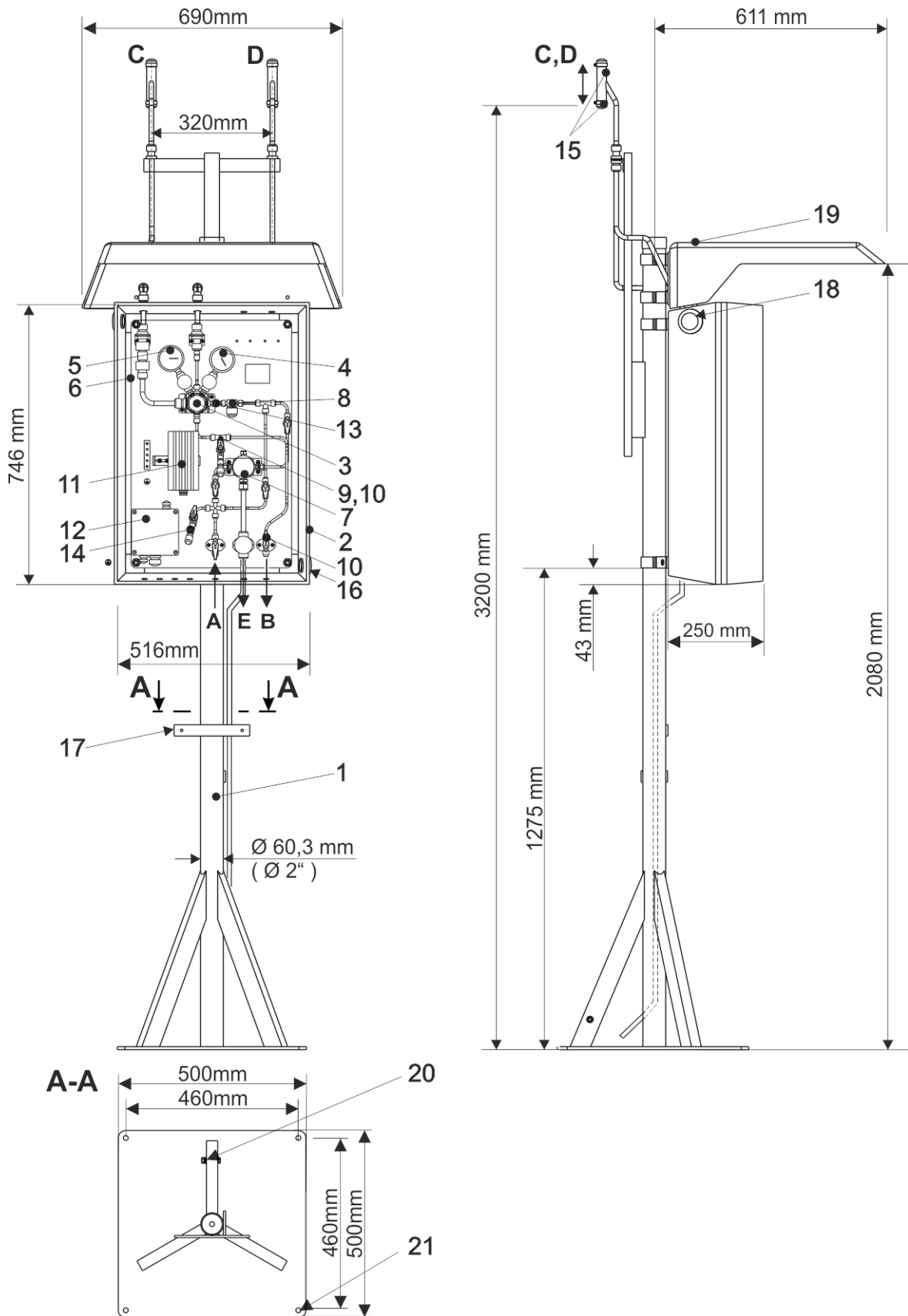

- | | |
|--|---|
| <ol style="list-style-type: none"> 1) Stand (stainless steel) 2) Isolation cabinet with window 3) Pressure reducer
inlet-pressure max. 100 bar
outlet-pressure 0,14-7 bar 4) Pressure gauge; selectable 0-160,
0-100, 0-40 bar 5) Pressure gauge; selectable *0-6,
0-10 bar 6) Relief valve with 3 bar opening
pressure 8) Sintered metal filter 9) Test port -low pressure area
(minimess-coupling type 1215) 10) Shut of valve 11) Heating (ex) 100W with integrated
thermostat in connecting cable-
frost free down to -25°C
(fixed value temperature 30°C) 12) Ex(e)(i)-connection box for pos.-
no.11,5 and
heating-sample gas line. 13) Integrated restriction ø0,4mm 15) Insect safety-sieve | <p>Options:</p> <ol style="list-style-type: none"> 7) Coalesce filter with bypass 14) Test port high-pressure area with
shut off valve
(minimess-coupling type 1215) 5) *With contact gauge (adjustable) <p>A. Gas inlet
B. Gas outlet
C. Vent line of relief valve
D. Vent line of pressure reducer
E. Outlet condensate</p> <p>Tube for connections A, B:
Standard-4mm tube, Options -1/8"-,
6mm tube
12mm tube for connections C, D, E.
Customer connections in
swagelok system.
Tube and connections material stain-
less steel.</p> <p>Weight total 70kg</p> |
|--|---|

Figure 19: Pressure Reducing Unit Type DRS200 (installation on rack)

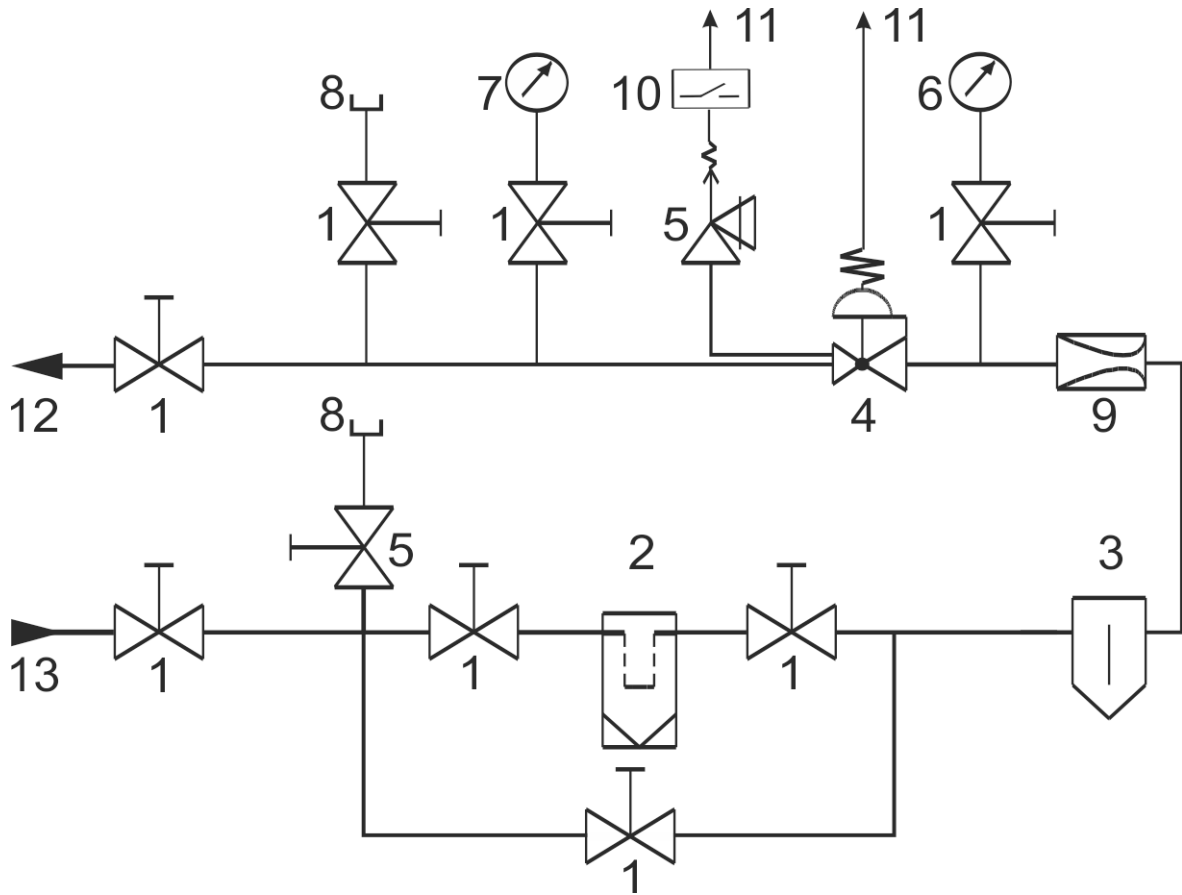

71

- | | | | |
|---|--------------------------|----|-----------------------------------|
| 1 | Shut-off valve | 8 | Test port |
| 2 | Coalescence filter | 9 | Restrictor |
| 3 | Filter | 10 | Flow alarm, relief valve (option) |
| 4 | Pressure reducer | 11 | To atmosphere |
| 5 | Relief valve | 12 | Outlet pressure = 0,14-7 bar |
| 6 | Primary pressure gauge | 13 | Inlet pressure = 100 bar (max) |
| 7 | Secondary pressure gauge | | |

Figure 20: Pressure Reducing Unit Type DRS200 (Functional Diagramm)

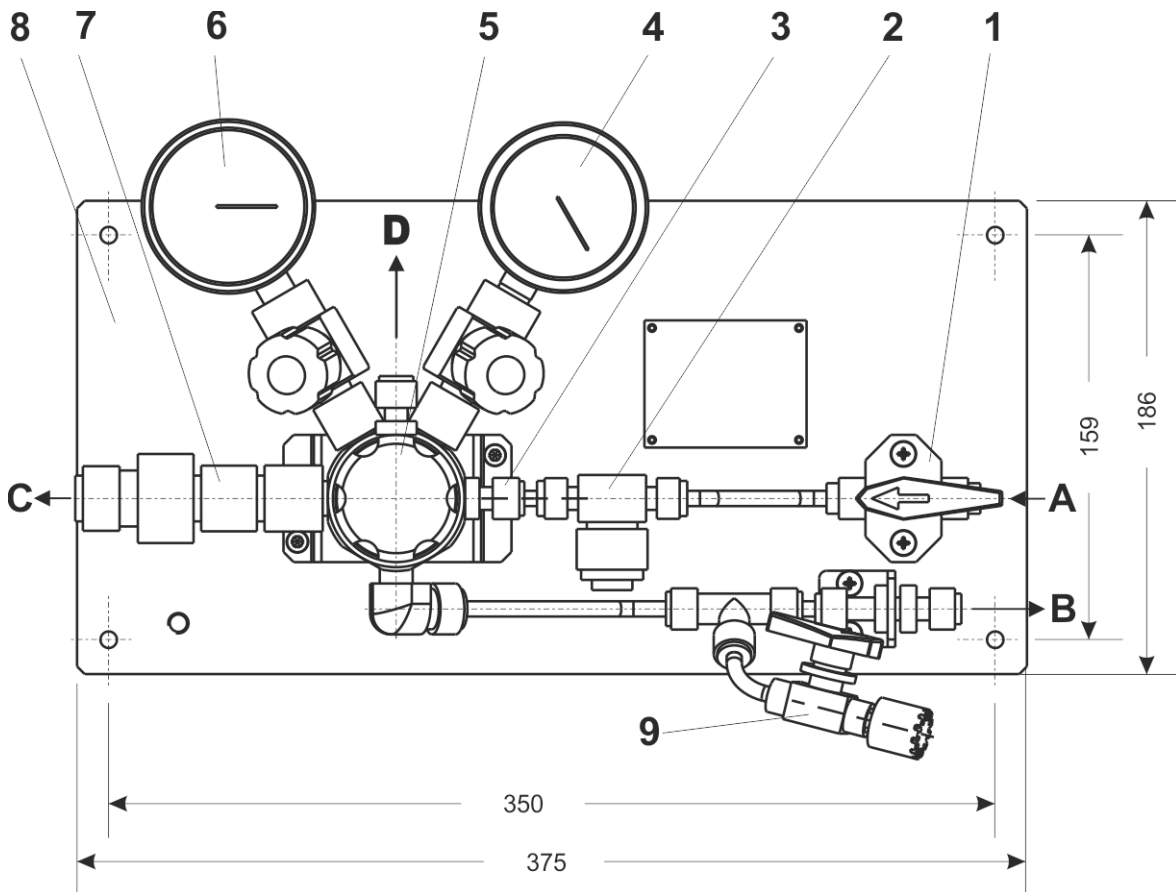

- 1) Shut off valve
- 2) Filter
- 3) Integrated restriction
- 4) Pressure gauge 0-160 bar
optional 0-100 bar, 0-40 bar
- 5) High-pressure reducer
Input: max. 100 bar
Output: 0,14-7 bar
- 6) Pressure gauge 0-6 bar
optional with contact gauge
- 7) Relief valve (adjustable) with
3 bar opening pressure
- 8) Mounting plate (Al)
- 9) Test port with shut off valve

Option:

Fixation to wall (option)

Connections:

- A. Gas inlet
6mm pipe (option 1/8", 3mm, 4mm)
- B. Gas outlet
6mm pipe (option 1/8", 3mm, 4mm)
- C. Vent line of relief valve
12mm pipe
- D. Vent line of pressure reducer
12mm pipe

Figure 21: Pressure Reducing Unit Type DRS100

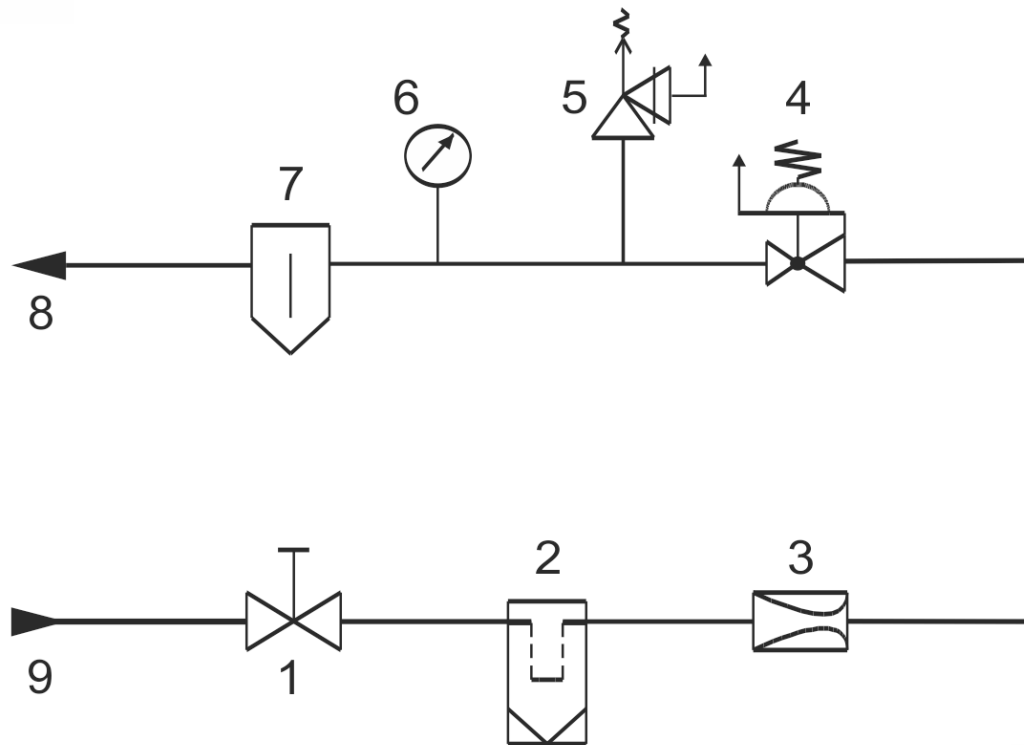

- 1 Shut-off valve (needle)
- 2 Gas filter
- 3 Restrictor
- 4 Pressure reducer 100/8 bar
- 5 Relief valve (8 bar)
- 6 Pressure gauge 0-16 bar
- 7 Gas dryer
- 8 Outlet pressure = 0-8 bar
- 9 Inlet pressure = 100 bar

Figure 22: Pressure Reducing Unit Type DRS100 (Functional Diagram)

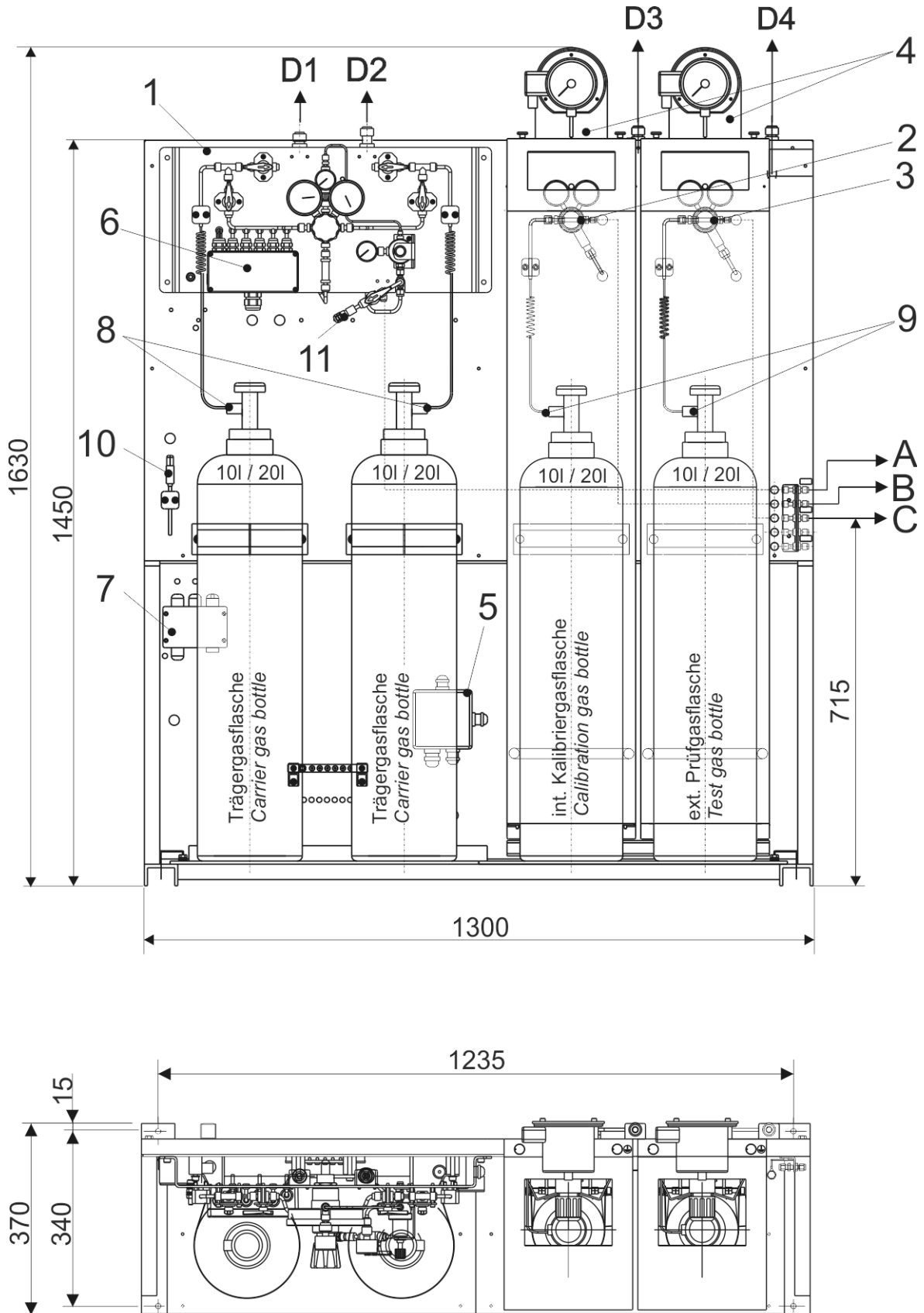

- | | | |
|--|--|--|
| <ul style="list-style-type: none"> 1) changeover unit automatic for two gas cylinders 10l / 20l 2) int. Calibration gas cylinder 10l / 20l (heated) with pressure regulator and relief valve 3) ext. test gas cylinder (heated) with pressure regulator and relief valve 4) thermostat for cylinder temperature 5) Ex(e) connection box for Ex cylinder heating 6) Ex(i) connection box for contact gauges (carrier gas cylinders) 7) Ex(i) connection box for bottle and room thermometer 8) high pressure spiral hose (stainless steel) with bottle connection DIN 477, no.6 or BS 341, no.3 9) high pressure spiral hose (stainless steel) with bottle connection DIN 477, no.14 or BS 341, no.4 | <p>Option:</p> <ul style="list-style-type: none"> 10.) room thermostat 11.) test connection with test port <p>Connections:</p> <ul style="list-style-type: none"> A) carrier gas outlet B) calibration gas outlet C) test gas outlet D1) vent line (carrier gas) D2) vent line (carrier gas) for fine pressure reducer D3) vent line of relief (calibration gas) D4) vent line of relief (test gas) <p>1/8" tube for connections A, B, C
 Ø 12mm tube for connections D1-D4</p> <p>All tube fittings and connections in Swagelok system and stainless steel</p> <p>Weight without bottles approx. 94 kg</p> | <hr style="border: 0; border-top: 1px solid black; margin-bottom: 5px;"/> <p>75</p> <hr style="border: 0; border-top: 1px solid black; margin-top: 5px;"/> |
|--|--|--|

Figure 23: Gas Supply Unit
With changeover unit for two carrier gas cylinders 10/20l

Appendix 2: Error messages

Errors are outputted by the analytical computer as a text message with a specific number. The error numbers are outputted in the print logs.

A complete list is provided in Appendix E of the GC 9300 manual.

Only the error messages directly related to the analysis should be addressed here.

Appendix 2 A: Error during operation

No.	Text	Description	Cause
14 - 17	Current output - # limit	Current < 0/2 mA and/or > 21mA	- Check of limit values in the "Detail" screen under "inputs and outputs"
50	Measuring element timeout	The measuring element no longer provides valid data.	- Communication error - Error in the measuring element
		<u>Communication error</u> The measuring element works correctly, but there are no measurements received by the analytical computer.	- Wire break - Incorrectly specified TCP/IP address in the analytical computer
120	Ana: Retention time	The retention time of one or multiple gas components deviates impermissibly from the base values. (Retention times in the "Detail" screen for the individual components, permissible deviation under "Computing parameters / limit values ana., cal.")	- Faulty pressure/temperature values (with error 50) - Impermissible gas composition (with error 121, 122) - Defective module
121	Ana: unnormalized total	With standardization to 100%, the limit value is exceeded ("Calibration results / area totals" and "Calibration parameters / limit values cal.").	- Impermissible gas composition - Pressure/temperature error (50) - Defective module
122	Ana: Concentration	Working range of the modules exceeded and/or undercut	- impermissible gas composition
123, 82, 124, 127	Ana: Ho min/max Ana: CO ₂ min/max Ana: Wo min/max Ana: Rho,n min/max	Measuring range exceeded and/or undercut	- Check of limit values in the "Detail" screen under "Components and parameters"
130	Measuring gas P-min / max	Depending on the inlet that is switched on, the inlet pressure of the measuring/calibrating or reference gas is outside of the tolerance.	- Incorrect setting - Cylinder pressure - Check "Status" screen
131	Carrier gas pressure -I	The carrier gas inlet pressure is outside of the tolerance.	- Incorrect setting - Cylinder pressure - Check "Status" screen

Appendix 2 B: Errors during recalibration

The following errors are only issued during the recalibration and/or basic calibration. If one of these errors occurs, the calibration is invalid. The previous response factors are retained. All of the subsequent measurements are marked as faulty.

These errors cannot be acknowledged and are not reset until a valid recalibration takes place.

Number	Text	Description	Cause
100	Cal: Retention time	The newly determined retention times (current and/or stream values under "Times") deviate impermissibly from the specified values ("Computing parameters / Ana., Cal. limit values")	<ul style="list-style-type: none"> - Pressure / temperature error during recalibration. - Calibrating gas supply - Faulty specification of calibrating gas concentration ("Detail" screen under "Calibrating parameters") - Defective module
101	Cal: Response factor	The newly calculated response factors show an impermissible deviation ("Detail" screen under "Calibration results" and "Calibration parameters / Cal. limit values")	- see 100
103	Cal: Total area	The total area determined in the calibration deviates by more than 30% from the value of the basic calibration.	- see 100

Appendix 3: Pre-filter flushing unit

The optionally available pre-filter flushing unit allows a carrier gas moisture filter to be changed while the downstream PGC 93xx is in operation. This significantly reduces interruptions to operating times due to filter replacement work.

To ensure the continuous operation of the PGC 93xx, two carrier gas humidity filters with associated inlet, outlet and vent valves are arranged redundantly in the pre-filter purge unit. The carrier gas flow can always be fed to the PGC 93xx via one filter with the corresponding valve position, while the second filter is changed and then flushed.

The pre-filter flushing unit must be installed in the carrier gas line upstream of the PGC 93xx (see *Figure 24: Installation diagram*).

79

Simple assembly

In order to enable easy replacement of the original pre-filter unit with the optional pre-filter flushing unit, the components were mounted on a base plate of the same size.

The external dimensions, the hole pattern of the wall mounting and the position of the carrier gas connections are identical to the original version. This means that when the pre-filter unit types are changed, they can be replaced without any problems.

Installation diagram

The following figure shows the functional arrangement of the pre-filter flushing unit in the carrier gas line.

80

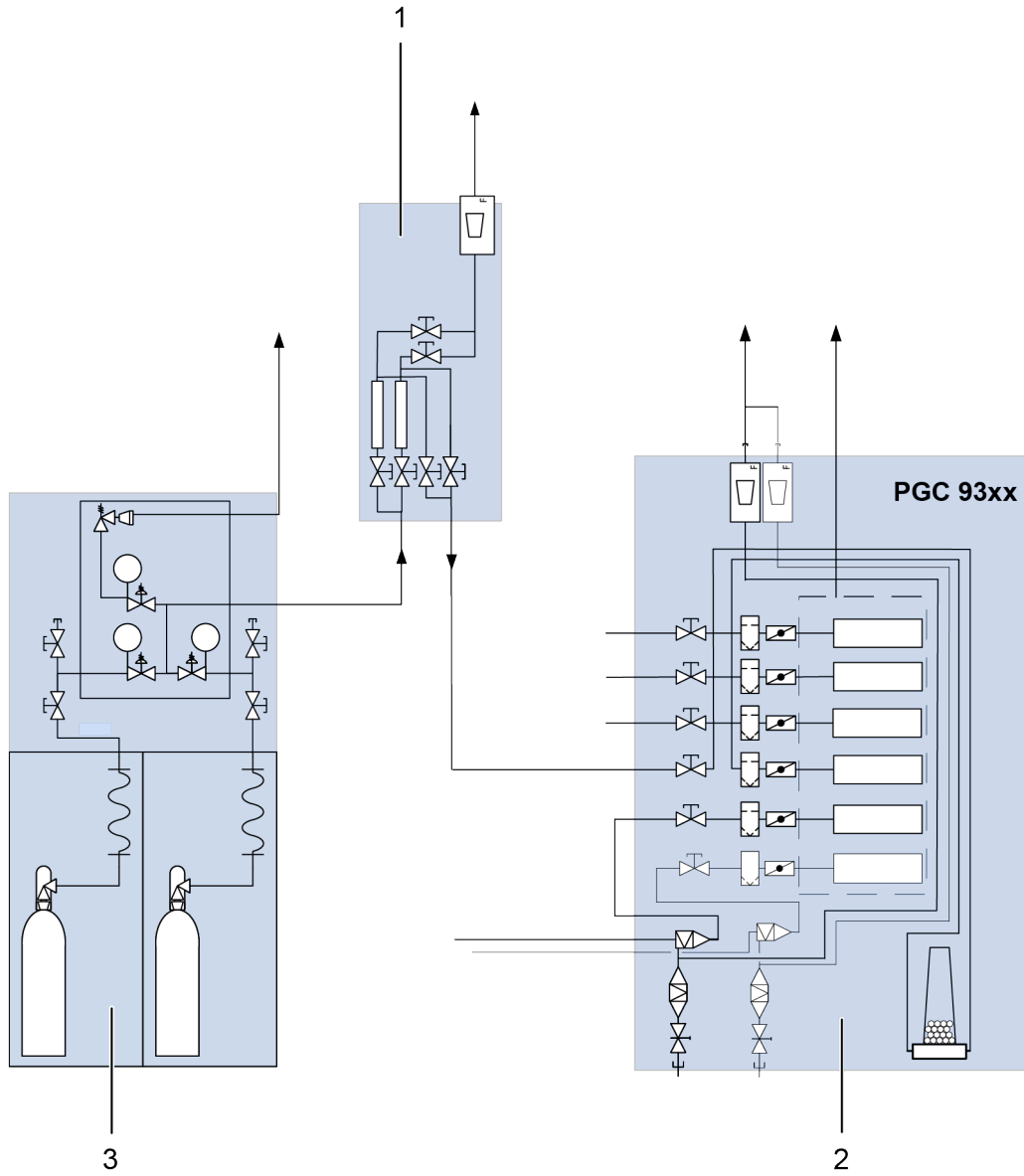

- 1 Pre-filter flushing unit
- 2 PGC 93xx

- 3 Carrier gas supply

Figure 24: Installation diagram

Functional diagram

The *Figure 25: Functional diagram and technical drawing* shows the components of the pre-filter flushing unit and their functional and actual arrangement. The *Figure 26: Pre-filter flushing unit without filter equipment* shows the photo of a prototype of the unit.

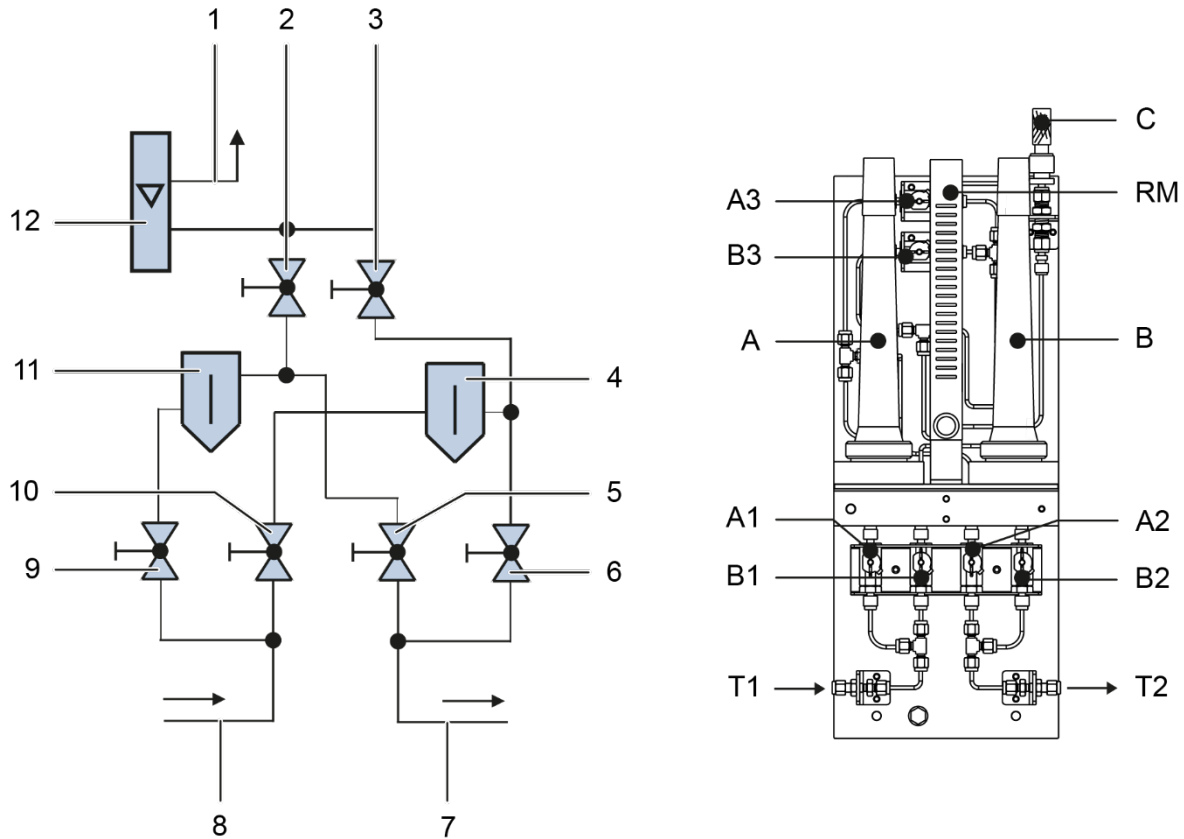

Item P&I	Item Drwg	Description	Item P&I	Item Drwg	Description
1	C	Connection to the blow-out pipe	7	T2	Outlet connection of the carrier gas to the RGC 7
2	A3	Shut-off valve Rinsing outlet filter A	8	T1	Inlet connection of the carrier gas from the gas supply
3	B3	Shut-off valve Rinsing outlet filter B	9	A1	Shut-off valve inlet filter A
4	B	Filter B (right filter)	10	B1	Shut-off valve inlet filter B
5	A2	Shut-off valve outlet filter A	11	A	Filter A (left filter)
6	B2	Shut-off valve outlet filter B	12	RM	Rotameter, adjustable

Figure 25: Functional diagram and technical drawing

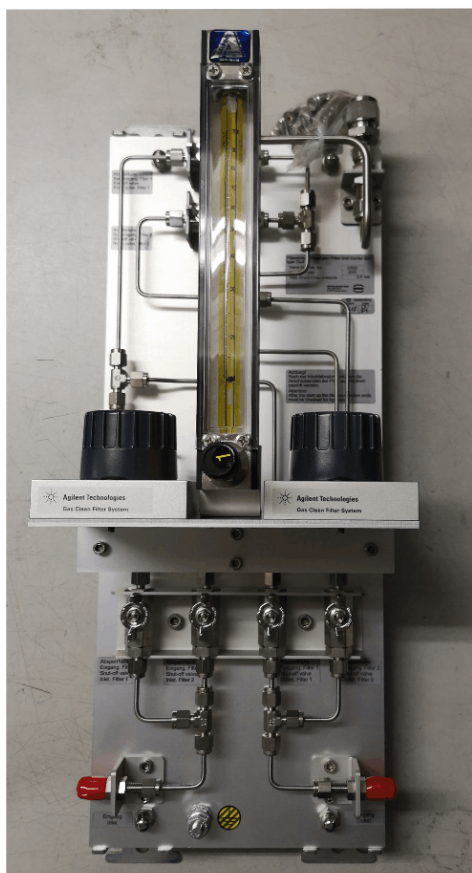

Figure 26: Pre-filter flushing unit without filter equipment

Pre-filter flushing unit brief operating instructions

Initial startup:

1. All valves are closed, no filter is used.
2. Switch HE filter to Pos. A. 83
3. Open valve A1.
4. Open valve A3.
5. Adjust rotameter RM for flushing operation to 10-15 ml.
Flush 24 h.
6. Close valve A3.
7. Open valve A2 (Filter A in operation).

Use new Filter B, Filter A is in operation:

1. Switch HE filter to Pos. B.
2. Open valve B1.
3. Open valve B3.
4. Adjust rotameter RM for flushing operation to 10-15 ml.
Flush 24 h.
5. Close valve B3.
6. Close valve A2.
7. Open valve B2.
8. Close valve A1.
9. Open valve A3 for ventilation and close again.
10. Filter A can be removed.

Use new Filter A, Filter B is in operation:

1. Switch HE filter to Pos. A.
2. Open valve A1.
3. Open valve A3.
4. Adjust rotameter RM for flushing operation to 10-15 ml.
Flush 24 h.
5. Close valve A3.
6. Close valve B2.
7. Open valve A2.
8. Close valve B1.
9. Open valve B3 for ventilation and shut again.
10. Filter B can be removed.

Appendix 4: Spare parts and accessories

Order number	Description
--------------	-------------

85

Measuring element

00.66.074.00	Filter unit carrier gas
30.00.087.00	Moisture Filter Agilent CP17971
90.26.125.00	Helium filter type RMSH-2
90.26.389.00	Filter FI1HTA-2T-2 HL Fa. Hy-Lok
90.26.415.00	Liquid stop LB-1SS Nr.03F4000+bypass
86.98.114.00	Power supply 24 V / 10.5 A
35.00.179.00	Phoenix QUINT Power Supply 24VDC/10A
35.00.180.00	Phoenix QUINT Power Supply 24VDC/20A
86.98.118.00	Interface adapter PSM-ME-RS232/TTY-P
86.98.175.01	PGC/VC interface adapter
38.00.047.00	Plate with Silicon heating elem. 24V/100W
90.19.660.00	Flow rate meter, type DK46/N
90.67.755.00	Insect prot. filter MW 0.5mm di=6mm
90.67.756.00	Insect prot. filter MW 0.5mm di=12mm
00.59.891.00	Insect protection filter for blower
84.07.011.00	Ball valve Series 110 BVH-2T-B-KT Hy-Lok
84.07.082.00	Ball valve (2-way) SS-42GS6MM-WL8-W1 SI

Analytical computer

91201-02480	PDA input metal stylus HAMA pack of 3
91201-02640	PDA input PVC stylus HAMA pack of 3
92403-02510	SD card4GB SD-4G0-XIE23 Xmore industrial
98800-15420	GC9300 Plug set complete

Gas supply unit

90.30.010.00	Purchase cylinder 10l helium 5.0 200bar co. DIN477-6
90.30.053.00	Purchase cylinder 20l helium 5.0 200bar co. DIN477-6
90.30.020.00	Purchase cylinder 50l helium 5.0 200bar co. DIN477-6
30.00.219.00	Purchase cylinder 10l argon 5.0 200bar co. DIN477-6
30.00.220.00	Purchase cylinder 50l argon 5.0 200bar co. DIN477-6
90.30.030.00	Purchase cylinder 10l cal. Gas 9M 150bar co. DIN477-14
90.30.014.00	Purchase cylinder 10l cal. Gas 11D 150bar co. DIN477-14
90.30.028.00	Purchase cylinder 10l cal. Gas 11M 150bar co. DIN477-14
90.30.008.00	Purchase cylinder 20l cal. Gas 12M 150bar co. DIN477-14
38.02.020.00	PCTFE seal 18x12x2 DIN477 No.1+6 CH ₄ ;He
38.02.021.00	PCTFE seal 14x9x2 DIN477 No.14 mixed gas
84.13.070.00	HP spiral 1/8" methane connector DIN477/1
84.13.071.00	HP spiral 1/8" helium connector DIN477/6
84.13.073.00	HP spiral 1/8" mixed gas connector DIN477/14
84.11.027.00	Pressure regulator LM53-6-L-200-4-OKMOAB-CH ₄
84.15.070.00	Bourdon gauge 0-4 bar Rch 40-3 rm
84.15.194.00	Bourdon gauge 0-16 bar Rch 40-3 rm
84.15.195.00	Bourdon gauge 0-6 bar ø 40G1/4 back, middle
86.90.062.00	Gas pressure thermometer type H7308+T min. contact
86.90.063.00	Gas pressure thermometer type H7308+T min/max.contact
86.96.621.00	Temperature sensor GTF101 (4-wire)
86.90.046.00	Ex-e connecting box type 8118/122-099
00.55.384.00	Automatic switch unit USE-3A

Pressure reducing unit

90.26.402.00	Filter SS-6TF-MM-7 SI
90.26.405.00	Coalescence filter PC 1410-E st.steel
90.26.434.10	P-cyl 20l 12M 150bar co.DIN477-14
90.45.153.00	Test port, series 1215
90.37.003.00	CP Multitherm type DNA 100 T3 TS 30

Appendix 5: Certificates

EU-Declaration of Conformity

Type Examination Certificate PGC9301

87

Type Examination Certificate PGC9302

Type Examination Certificate PGC9303

Type Examination Certificate PGC9304

EC-Type Examination Certificate DMT 00 ATEX E 001 7th Supplement

Note

EU declaration of conformity

The declaration of conformity presented reflects the situation on the data when the operating manual was issued. The latest version of the EU declaration of conformity is available from our website www.rmg.com.

EU-Declaration of Conformity
EU-Konformitätserklärung



We **RMG Messtechnik GmbH**
Wir Otto – Hahn – Straße 5
35510 Butzbach
Germany

Declare under our sole responsibility that the product is in conformity with the directives. Product is labeled according to the listed directives and standards and in accordance with the Type-Examination.
Erklären in alleiniger Verantwortung, dass das Produkt konform ist mit den Anforderungen der Richtlinien. Das entsprechend gekennzeichnete Produkt ist nach den aufgeführten Richtlinien und Normen hergestellt und stimmt mit dem Baumuster überein.

Product **Process Gas Chromatograph**
Type PGC 9301, PGC 9302, PGC 9303, PGC 9304 and GC 9310

Produkt **Prozess-Gaschromatograph**
Typ PGC 9301, PGC 9302, PGC 9303, PGC 9304 und GC 9310

Harmonisation Legislations <i>Harmonisierungsrechtsvorschriften</i>	EMV	ATEX
EU- Directives <i>EU-Richtlinie</i>	2014/30/EU	2014/34/EU
Marking <i>Kennzeichen</i>	---	II 2G Ex db e IIB+H ₂ T5/T4 Gb
Normative Documents <i>Normative Dokumente</i>	EN 61326-1:2006 IEC 61000-4-2: 1995 IEC 61000-4-3: 2002 IEC 61000-4-4: 2004 IEC 61000-4-5: 1995 IEC 61000-4-6: 2003 IEC 61000-4-8: 1993	EN IEC 60079-0: 2018 EN 60079-1: 2014 EN IEC 60079-7: 2015 + A1: 2018
EC Type-Examination issued by <i>EG-Baumusterprüfung ausgestellt durch</i>	Prüfbericht / Test Report: FS-1104-173643-001 (Nemko GmbH)	Modul B DMT 00 ATEX E 001
Approval of a Quality System by <i>Anerkennung eines Qualitätssicherungs-systems durch</i>	---	Modul D BVS 23 ATEX ZQS/E139 Notified Body: 0158 DEKRA Testing and Certification GmbH



The object of the declaration described above is in conformity with Directive 2011/65/EU of the European Parliament and of the Council of 8 June 2011 on the restriction of the use of certain hazardous substances in electrical and electronic equipment.

Der oben beschriebene Gegenstand der Erklärung erfüllt die Vorschriften der Richtlinie 2011/65/EU des Europäischen Parlaments und des Rates vom 8. Juni 2011 zur Beschränkung der Verwendung bestimmter gefährlicher Stoffe in Elektro- und Elektronikgeräten.

RMG Messtechnik GmbH
Butzbach, den 30.09.2024

Thorsten Dietz
(CEO)

Sascha Körner
(Technical Manager)

Sitz der Gesellschaft Butzbach • Registergericht Friedberg HRB 2535
Geschäftsführung Thorsten Dietz
Qualitätsmanagement DIN EN ISO 9001:2015

Seite 1 von 1



Physikalisch-Technische Bundesanstalt
Nationales Metrologieinstitut

KBS

Konformitätsbewertungsstelle



Baumusterprüfbescheinigung

Type-examination Certificate

Ausgestellt für: <i>Issued to:</i>	RMG Messtechnik GmbH Otto-Hahn-Str. 5 35510 Butzbach	
gemäß: <i>In accordance with:</i>	Anlage 4 Modul B der Mess- und Eichverordnung vom 11.12.2014 (BGBl. I S. 2010) <i>Annex 4 Modul B of the Measures and Verification Ordinance dated 11.12.2014 (Federal Law Gazette I, p. 2010)</i>	
Geräteart: <i>Type of instrument:</i>	Gasbeschaffenheitsmessgerät <i>Device to determine the gas quality</i> Prozessgaschromatograph (PGC)	
Typbezeichnung: <i>Type designation:</i>	PGC 9301	
Nr. der Bescheinigung: <i>Certificate No.:</i>	DE-16-M-PTB-0015, Revision 3	
Gültig bis: <i>Valid until:</i>	12.12.2026	
Anzahl der Seiten: <i>Number of pages:</i>	44	
Geschäftszeichen: <i>Reference No.:</i>	PTB-3.31-4099525	
Nr. der Stelle: <i>Body No.:</i>	0102	
Zertifizierung: <i>Certification:</i>	Braunschweig, 26.08.2021	Bewertung: <i>Evaluation:</i>
Im Auftrag <i>On behalf of PTB</i>	Siegel <i>Seal</i>	Im Auftrag <i>On behalf of PTB</i>
 Dr. Bert Anders		 Helga Bettin

Baumusterprüfbescheinigungen ohne Unterschrift und Siegel haben keine Gültigkeit. Diese Baumusterprüfbescheinigung darf nur unverändert weiterverbreitet werden. Auszüge bedürfen der Genehmigung der Physikalisch-Technischen Bundesanstalt.
Type-examination Certificates without signature and seal are not valid. This Type-examination Certificate may not be reproduced other than in full. Extracts may be taken only with the permission of the Physikalisch-Technische Bundesanstalt.

RG-0012



Physikalisch-Technische Bundesanstalt
Nationales Metrologieinstitut

KBS

Konformitätsbewertungsstelle

90



KOPIE

Baumusterprüfbescheinigung

Type-examination Certificate

Ausgestellt für: <i>Issued to:</i>	RMG Messtechnik GmbH Otto-Hahn-Str. 5 35510 Butzbach	
gemäß: <i>In accordance with:</i>	Anlage 4 Modul B der Mess- und Eichverordnung vom 11.12.2014 (BGBl. I S. 2010) <i>Annex 4 Modul B of the Measures and Verification Ordinance dated 11.12.2014 (Federal Law Gazette I, p. 2010)</i>	
Geräteart: <i>Type of instrument:</i>	Gasbeschaffenheitsmessgerät <i>Device to determine the gas quality</i> Prozessgaschromatograph (PGC)	
Typbezeichnung: <i>Type designation:</i>	PGC 9302	
Nr. der Bescheinigung: <i>Certificate No.:</i>	DE-16-M-PTB-0018, Revision 2	
Gültig bis: <i>Valid until:</i>	08.03.2027	
Anzahl der Seiten: <i>Number of pages:</i>	43	
Geschäftszeichen: <i>Reference No.:</i>	PTB-3.31-4118977	
Nr. der Stelle: <i>Body No.:</i>	0102	
Zertifizierung: <i>Certification:</i>	Braunschweig, 20.09.2024	Bewertung: <i>Evaluation:</i>
Im Auftrag <i>On behalf of PTB</i>	Siegel <i>Seal</i>	Im Auftrag <i>On behalf of PTB</i>
 Dr. Bert Anders		 Helga Bettin

Baumusterprüfbescheinigungen ohne Unterschrift und Siegel haben keine Gültigkeit. Diese Baumusterprüfbescheinigung darf nur unverändert weiterverbreitet werden. Auszüge bedürfen der Genehmigung der Physikalisch-Technischen Bundesanstalt.

Type-examination Certificates without signature and seal are not valid. This Type-examination Certificate may not be reproduced other than in full. Extracts may be taken only with the permission of the Physikalisch-Technische Bundesanstalt.

R3-0012



Physikalisch-Technische Bundesanstalt
Nationales Metrologieinstitut

KBS

Konformitätsbewertungsstelle

91



KOPIE

Baumusterprüfbescheinigung

Type-examination Certificate

Ausgestellt für: <i>Issued to:</i>	RMG Messtechnik GmbH Otto-Hahn-Str. 5 35510 Butzbach	
gemäß: <i>In accordance with:</i>	Anlage 4 Modul B der Mess- und Eichverordnung vom 11.12.2014 (BGBl. I S. 2010) <i>Annex 4 Modul B of the Measures and Verification Ordinance dated 11.12.2014 (Federal Law Gazette I, p. 2010)</i>	
Geräteart: <i>Type of instrument:</i>	Gasbeschaffenheitsmessgerät <i>Device to determine the gas quality</i> Prozessgaschromatograph (PGC)	
Typbezeichnung: <i>Type designation:</i>	PGC 9303	
Nr. der Bescheinigung: <i>Certificate No.:</i>	DE-16-M-PTB-0016, Revision 2	
Gültig bis: <i>Valid until:</i>	08.03.2027	
Anzahl der Seiten: <i>Number of pages:</i>	44	
Geschäftszeichen: <i>Reference No.:</i>	PTB-3.31-4118978	
Nr. der Stelle: <i>Body No.:</i>	0102	
Zertifizierung: <i>Certification:</i>	Braunschweig, 20.09.2024	Bewertung: <i>Evaluation:</i>
Im Auftrag <i>On behalf of PTB</i>	Siegel <i>Seal</i>	Im Auftrag <i>On behalf of PTB</i>
Dr. Bert Anders		Helga Bettin

Baumusterprüfbescheinigungen ohne Unterschrift und Siegel haben keine Gültigkeit. Diese Baumusterprüfbescheinigung darf nur unverändert weiterverbreitet werden. Auszüge bedürfen der Genehmigung der Physikalisch-Technischen Bundesanstalt.
Type-examination Certificates without signature and seal are not valid. This Type-examination Certificate may not be reproduced other than in full. Extracts may be taken only with the permission of the Physikalisch-Technische Bundesanstalt.

R3-0012



Physikalisch-Technische Bundesanstalt
Nationales Metrologieinstitut

KBS

Konformitätsbewertungsstelle

92



KOPIE

Baumusterprüfbescheinigung

Type-examination Certificate

Ausgestellt für: <i>Issued to:</i>	RMG Messtechnik GmbH Otto-Hahn-Str. 5 35510 Butzbach	
gemäß: <i>In accordance with:</i>	Anlage 4 Modul B der Mess- und Eichverordnung vom 11.12.2014 (BGBl. I S. 2010) <i>Annex 4 Modul B of the Measures and Verification Ordinance dated 11.12.2014 (Federal Law Gazette I, p. 2010)</i>	
Geräteart: <i>Type of instrument:</i>	Gasbeschaffenheitsmessgerät <i>Device to determine the gas quality</i> Prozessgaschromatograph (PGC)	
Typbezeichnung: <i>Type designation:</i>	PGC 9304	
Nr. der Bescheinigung: <i>Certificate No.:</i>	DE-15-M-PTB-0029, Revision 4	
Gültig bis: <i>Valid until:</i>	22.07.2025	
Anzahl der Seiten: <i>Number of pages:</i>	46	
Geschäftszeichen: <i>Reference No.:</i>	PTB-3.31-4118979	
Nr. der Stelle: <i>Body No.:</i>	0102	
Zertifizierung: <i>Certification:</i>	Braunschweig, 23.09.2024	Bewertung: <i>Evaluation:</i>
Im Auftrag <i>On behalf of PTB</i>	Siegel <i>Seal</i>	Im Auftrag <i>On behalf of PTB</i>
 Dr. Bert Anders		 Helga Bettin

Baumusterprüfbescheinigungen ohne Unterschrift und Siegel haben keine Gültigkeit. Diese Baumusterprüfbescheinigung darf nur unverändert weiterverbreitet werden. Auszüge bedürfen der Genehmigung der Physikalisch-Technischen Bundesanstalt.
Type-examination Certificates without signature and seal are not valid. This Type-examination Certificate may not be reproduced other than in full. Extracts may be taken only with the permission of the Physikalisch-Technische Bundesanstalt.

R3-0012



(1) **7. Nachtrag zur EG-Baumusterprüfbescheinigung**

- (2) Geräte und Schutzsysteme zur bestimmungsgemäßen Verwendung in explosionsgefährdeten Bereichen - Richtlinie 94/9/EG Ergänzung gemäß Anhang III Ziffer 6
- (3) Nr. der EG-Baumusterprüfbescheinigung: **DMT 00 ATEX E 001**
- (4) Gerät: **Prozess-Gaschromatograph Typ PGC 9*** ***
- (5) Hersteller: **RMG Messtechnik GmbH**
- (6) Anschrift: **Otto-Hahn-Straße 5, 35510 Butzbach**
- (7) Die Bauart dieser Geräte sowie die verschiedenen zulässigen Ausführungen sind in der Anlage zu diesem Nachtrag festgelegt.
- (8) Die Zertifizierungsstelle der DEKRA EXAM GmbH, benannte Stelle Nr. 0158 gemäß Artikel 9 der Richtlinie 94/9/EG des Europäischen Parlaments und des Rates vom 23. März 1994, bescheinigt, dass diese Geräte die grundlegenden Sicherheits- und Gesundheitsanforderungen für die Konzeption und den Bau von Geräten und Schutzsystemen zur bestimmungsgemäßen Verwendung in explosionsgefährdeten Bereichen gemäß Anhang II der Richtlinie erfüllen. Die Ergebnisse der Prüfung sind in dem Prüfprotokoll BVS PP 00.2003 EG niedergelegt.
- (9) Die grundlegenden Sicherheits- und Gesundheitsanforderungen werden erfüllt durch Übereinstimmung mit
EN 60079-0:2012 + A11:2013 Allgemeine Anforderungen
EN 60079-1:2014 Druckfeste Kapselung „d“
EN 60079-7:2007 Erhöhte Sicherheit „e“
- (10) Falls das Zeichen "X" hinter der Bescheinigungsnummer steht, wird in der Anlage zu dieser Bescheinigung auf besondere Bedingungen für die sichere Anwendung des Gerätes hingewiesen.
- (11) Dieser Nachtrag zur EG-Baumusterprüfbescheinigung bezieht sich nur auf die Konzeption und die Baumusterprüfung der beschriebenen Geräte in Übereinstimmung mit der Richtlinie 94/9/EG. Für Herstellung und Inverkehrbringen der Geräte sind weitere Anforderungen der Richtlinie zu erfüllen, die nicht durch diese Bescheinigung abgedeckt sind.
- (12) Die Kennzeichnung des Gerätes muss die folgenden Angaben enthalten:

 **II 2G Ex db e IIB+H₂ T5/T4 Gb**

DEKRA EXAM GmbH
Bochum, den 10.08.2015

Zertifizierungsstelle

Fachbereich



Seite 1 von 3 zu DMT 00 ATEX E 001 / N7
Dieses Zertifikat darf nur vollständig und unverändert weiterverbreitet werden.

DEKRA EXAM GmbH, Dinnendahlstraße 9, 44809 Bochum, Deutschland
Telefon +49.234.3696-105, Telefax +49.234.3696-110, zs-exam@dekra.com



- (13) Anlage zum
- (14) **7. Nachtrag zur EG-Baumusterprüfbescheinigung DMT 00 ATEX E 001**
- (15) 15.1 Gegenstand und Typ

Prozess-Gaschromatograph Typ PGC 9*** *

Mögliche Varianten

- PGC90** VC Zwei Messeinheiten Typ CP4002
- PGC 90** BBQ Eine Messeinheit Typ CP4002
- PGC 93** Drei Messeinheiten Typ CP4900

Die Sternchen sind für den Explosionsschutz nicht relevant.

15.2 Beschreibung

Der Prozess Gaschromatograph PGC 9*** * dient der Analyse von betriebsmäßig nicht explosionsfähigen gasförmigen Substanzen. Es werden nur betriebsmäßig nicht explosionsfähige Gasgemische analysiert. Der maximale Sauerstoffanteil brennbarer Gasgemische liegt bei 5 % und somit unterhalb der Sauerstoffgrenzkonzentration. Acetylen und Schwefelkohlenstoff sind ausgeschlossen. Als Trägergas wird Helium oder Argon verwendet.

Der Anschluss des Prozess Gaschromatographen Typ PGC 9*** * erfolgt über einen Anschlusskasten Typ SA141410 (CESI 03 ATEX 333) in der Zündschutzart Erhöhte Sicherheit „e“. Die Anzahl der Reihenklammern im Anschlusskasten beträgt 29.

Die Analyse der Gase erfolgt in einem Gehäuse Typ CCFE-5B oder EJB-5B (CESI 00 ATEX 036 U) in der Zündschutzart Druckfeste Kapselung „d“.

Der Prozess Gaschromatograph Typ PGC 90** * kann zusätzlich mit einem Messwerk Typ OXOS 08 ausgestattet werden. Die Nennleistung erhöht sich für den Typ PGC 90** * um 10 W durch das zusätzliche Messwerk.

Vor Inbetriebnahme der Wärmeleitfähigkeitsdetektoren wird durch Vorspülung mit Trägergas sichergestellt, dass der Analysenweg frei von explosionsfähigem Gemisch ist.

Der Prozess Gaschromatograph wird in die wiederkehrende Druckprüfung der Anlage einbezogen.

Auflistung aller verwendeten Komponenten mit älterem Normenstand

Gegenstand und Typ	Zertifikat	Normen
Gehäuse Typ CCFE-5B (EJB-5B)	CESI 00 ATEX 036 U	EN 60079-0:2009 EN 60079-1:2007 EN 60079-31:2009
Leitungsdurchführung Typ NPS	CESI 01 ATEX 080U	EN 60079-0:2012 EN 60079-1:2007 EN 60079-31:2009
Verschlussstopfen Typ 8294/1...-...	PTB 02 ATEX E 1066 U	EN 60079-0:2012 EN 60079-1:2007 EN60079-7:2007 EN 60079-31:2009

Gründe dieses Nachtrags sind die folgenden Änderungen:

- Änderung der Gasgruppe von IIB auf IIB+H₂
- Neue wahlweise Konstruktion der Flammensperren mit Sintermetallelementen.
- Neue wahlweise Konstruktion der Durchflussbegrenzer.
- Anhebung des Normenstandes der EN 60079-1:2007 auf EN 60079-1:2014.



Seite 2 von 3 zu DMT 00 ATEX E 001 / N7
Dieses Zertifikat darf nur vollständig und unverändert weiterverbreitet werden.

DEKRA EXAM GmbH, Dinnendahlstraße 9, 44809 Bochum, Deutschland
Telefon +49.234.3696-105, Telefax +49.234.3696-110, zs-exam@dekra.com



15.3 Kenngrößen

Elektrische Kenngrößen (Versorgung)

Nennspannung		230 V AC
	oder	24 V DC

Elektrische Kenngrößen (Analysator)

Nennspannung	Analysator		24 V DC
Nennspannung	PGC 90** VC	≤	125 W
Nennspannung	PGC 90** BBQ	≤	113 W
Nennspannung	PGC 93**	≤	178 W

Thermische Kenngrößen

Umgebungstemperaturbereich	Temperaturklasse T5	$-20\text{ °C} \leq T_{\text{amb}} \leq 40\text{ °C}$
Umgebungstemperaturbereich	Temperaturklasse T4	$-20\text{ °C} \leq T_{\text{amb}} \leq 60\text{ °C}$

(16) Prüfprotokoll

BVS PP 00.2003 EG, Stand 10.08.2015

(17) Besondere Bedingungen für die sichere Anwendung

Entfällt weiterhin

Seite 3 von 3 zu DMT 00 ATEX E 001 / N7
 Dieses Zertifikat darf nur vollständig und unverändert weiterverbreitet werden.
 DEKRA EXAM GmbH, Dinnendahlstraße 9, 44809 Bochum, Deutschland
 Telefon +49.234.3696-105, Telefax +49.234.3696-110, zs-exam@dekra.com



Contact

Subject to technical modifications

For further information

If you would like to learn more about the products and solutions from RMG, please visit our website:

www.rmg.com

or your local support office
or contact your local sales representative

RMG Messtechnik GmbH

Otto-Hahn-Straße 5

35510 Butzbach, Germany

Phone: +49 (0) 6033 897 – 0

Fax: +49 (0) 6033 897 – 130

Email: service@rmg.com

