

## Operating Manual

# Flow Computer Series ERZ 2000-NG

Issued: 2025, February 3rd  
 Version: 09.1  
 Firmwareversion: 1.8

**Manufacturer** Contact our customer service department for technical information.

<b>Address</b>	RMG Messtechnik GmbH Otto-Hahn-Straße 5 D-35510 Butzbach (Germany)
<b>Main office</b>	+49 6033 897 – 0
<b>Service</b>	+49 6033 897 – 0
<b>Spare parts</b>	+49 6033 897 – 173
<b>Fax</b>	+49 6033 897 – 130
<b>Email</b>	<a href="mailto:service@rmg.com">service@rmg.com</a>

**Translation of the original document** The manual **ERZ2000NG\_manual\_de\_09.1** of 2025, February 3rd for the flow computer ERZ2000-NG is the document translated first from the German original version. Anyhow, this document may serve as reference for translations into other languages. Please use in case of any uncertainties the German version as main reference.

**Note** The latest version of this manual (and other devices) can be downloaded at your convenience from our Internet page:

[www.rmg.com](http://www.rmg.com).

<b>Created</b>	January	2013
<b>1<sup>st</sup> revision</b>	July	2013
<b>2<sup>nd</sup> revision</b>	April	2014
....		
<b>8<sup>th</sup> revision</b>	September	2019
<b>9<sup>th</sup> revision</b>	October	2023

<b>Document version and language</b>	<b>Document version</b>	ERZ2000NG_manual_de_09.1 2025, February 3rd
	<b>Language</b>	EN

# TABLE OF CONTENTS

## 1 ABOUT THIS MANUAL..... 1

<b>1.1</b>	<b>Structure of the manual .....</b>	<b>1</b>
<b>1.2</b>	<b>Purpose of the manual .....</b>	<b>2</b>
1.2.1	Abbreviations .....	2
1.2.2	Symbols .....	4
1.2.3	Structure of notices .....	4
1.2.4	Working with the device .....	5
1.2.5	Risk assessment and minimization .....	9
1.2.6	Applicability of the manual .....	10
1.2.7	Transport .....	11
1.2.8	Scope of delivery .....	11
1.2.9	Disposal of packaging material .....	12
1.2.10	Storage .....	12
<b>1.3</b>	<b>Function .....</b>	<b>13</b>
<b>1.4</b>	<b>Overview .....</b>	<b>14</b>
<b>1.5</b>	<b>Areas of application .....</b>	<b>15</b>
1.5.1	Device type adjustment .....	16
1.5.2	Use in gas measurement technology .....	17
1.5.3	Seal diagram for devices with MID approval .....	19
1.5.4	Signature, software and hardware data .....	22

## 2 INTRODUCTION..... 28

<b>2.1</b>	<b>Operation.....</b>	<b>28</b>
2.1.1	Front panel .....	28
2.1.2	Operation on the touch screen .....	29
2.1.3	Remote control / parameterization .....	29
<b>2.2</b>	<b>Live browser and coordinate system .....</b>	<b>35</b>
2.2.1	Display .....	41
<b>2.3</b>	<b>Access protection for data and settings .....</b>	<b>47</b>
<b>2.4</b>	<b>Basic settings .....</b>	<b>51</b>
<b>2.5</b>	<b>Start screen.....</b>	<b>54</b>
2.5.1	Overview.....	56
2.5.2	Service.....	69
2.5.3	Details.....	71
2.5.4	4 Lines .....	71
2.5.5	Functions .....	72
2.5.6	Archive.....	82
2.5.7	Alarm, warning message .....	85

2.5.8	Trend .....	87
2.5.9	Maximum load .....	88
<b>2.6</b>	<b>Time system.....</b>	<b>90</b>
2.6.1	KA Times and time settings.....	90
2.6.2	KB Time contact signal to external devices.....	93
2.6.3	KC external time signal.....	94
2.6.4	KD Plausibility.....	98
<b>2.7</b>	<b>Electrical connections .....</b>	<b>99</b>
2.7.1	Equipment variants.....	99
2.7.2	Configuration of connections .....	101
2.7.3	Terminal assignment .....	104
2.7.4	Data interfaces .....	108
2.7.5	Pin assignment and recommended use of the interfaces.....	110
2.7.6	External modem connection .....	115
2.7.7	Connections.....	120
2.7.8	Activation of inputs and outputs.....	125
2.7.9	Assignment of "physical values" .....	128
2.7.10	MA Input / output function key .....	128
2.7.11	NA Current input 1 .....	131
2.7.12	NI Res. input 1 .....	132
2.7.13	NL Frequency input 1 .....	133
2.7.14	NT Contact inputs.....	134
2.7.15	NU Current input 9 Exi.....	135
2.7.16	NY Resistance measurement 3.....	136
2.7.17	MB Current output 1 .....	137
2.7.18	MF Pulse output 1 .....	139
2.7.19	MJ Contact output 1 .....	142
2.7.20	MR Frequency output 1 .....	143
2.7.21	Revision switch.....	144

## **3 COMMUNICATION AND BUS SYSTEMS..... 145**

<b>3.1</b>	<b>Bus systems .....</b>	<b>145</b>
<b>3.2</b>	<b>DSfG bus .....</b>	<b>146</b>
<b>3.3</b>	<b>MODBUS .....</b>	<b>149</b>
3.3.1	Concept .....	149
3.3.2	Modbus master overview.....	151
<b>3.4</b>	<b>NAMUR sensor adjustment (optional).....</b>	<b>161</b>
<b>3.5</b>	<b>Settings for communication .....</b>	<b>162</b>
3.5.1	IA TCP/IP network.....	162
3.5.2	IC DSfG instance computer.....	163
3.5.3	ID DSfG entity recording.....	165
3.5.4	IE Remote data transmission access .....	167
3.5.5	IF DSfG master.....	170

<b>4</b>	<b>TRANSMITTERS .....</b>	<b>173</b>
4.1	Measurements .....	174
4.2	Pressure transducer.....	176
4.3	Temperature transducer .....	183
4.3.1	AL internal temperature of the device.....	184
4.4	Special measurements.....	185
<b>5</b>	<b>FLOW METERS.....</b>	<b>186</b>
5.1	<b>General settings .....</b>	<b>186</b>
5.1.1	AQ 4-20 mA flow .....	186
5.1.2	GB Flow rate parameters .....	187
5.1.3	GC kv factor.....	196
5.1.4	GD Characteristic curve determination.....	197
5.1.5	GE Error curve linearisation, forward flow .....	199
5.1.6	GG Flow .....	203
5.1.7	GH Start-up and shut-down monitoring .....	203
5.1.8	HB Energy flow.....	204
5.1.9	OO Extra counter.....	205
5.2	<b>Turbine meter.....</b>	<b>206</b>
5.2.1	EC Billing mode .....	207
5.3	<b>Ultrasonic gas meter .....</b>	<b>212</b>
5.3.1	GJ Body compensation .....	216
5.3.2	UA Ultrasonic volume transmitter .....	217
5.3.3	UB USZ Reynolds correction.....	218
5.3.4	UC Base correction .....	219
5.3.5	UD Err.curve correction.....	219
5.3.6	UE Effects of correct.....	220
5.3.7	UF ID display IGM 1 .....	221
5.3.8	UJ Path 1 .....	222
5.3.9	VA Current velocity of gas .....	222
5.3.10	VB Speed of sound.....	223
5.3.11	VC Ultrasonic profile.....	224
5.3.12	VD Volume flow .....	224
5.3.13	VE Messages .....	225
5.3.14	VF Signal acceptance.....	225
5.3.15	VG Signal-to-noise ratio .....	226
5.3.16	VH Automatic gain control .....	227
5.3.17	VI Gas speed hourly mean value .....	227
5.3.18	LO Digital totalizer transmission .....	228
5.4	<b>Connection of USZs via Instance F.....</b>	<b>229</b>
5.4.1	Explanation of the term Instance F.....	229
5.4.2	Modbus communication with the USM GT400 .....	230
5.4.3	Electrical connection.....	230
5.4.4	USM GT400 connection area .....	230

5.4.5	Configuration for COM6 and COM7 .....	231
5.4.6	Volume transmitter operating mode .....	236
5.4.7	Protocol type in menu VJ Register plots.....	237
5.4.8	COM6 interface configuration.....	238
5.4.9	Configuration VK Modbus according to Instance F .....	239
5.4.10	Configuration menu VK for USM GT400 RS 485-1 .....	240
5.4.11	Configuration USM GT400 for Instance F .....	241
5.4.12	Modbus register for Instance F.....	243
5.4.13	OX RMGView Trigger.....	248
<b>5.5</b>	<b>Orifice plate diameter.....</b>	<b>249</b>
5.5.1	GA Tube dimensions.....	251
5.5.2	AP diff.pressure.....	254
5.5.3	Special case zero point calibration of all delta-p cells .....	258
<b>6</b>	<b>PARAMETER OF THE GAS .....</b>	<b>262</b>
<b>6.1</b>	<b>Direct gas parameters.....</b>	<b>262</b>
6.1.1	BA Components mode .....	262
6.1.2	BB Carbon dioxide.....	264
6.1.3	BE Methane.....	265
<b>6.2</b>	<b>Additional gas values.....</b>	<b>266</b>
6.2.1	AD Superior calorific value .....	267
6.2.2	AE Standard density.....	269
6.2.3	LU Quantity weighted average values.....	270
6.2.4	AF Relative density.....	271
6.2.5	AG Density .....	271
6.2.6	AH Temperature of the density transmitter.....	271
6.2.7	AI Temperature for VOS correction .....	271
6.2.8	AJ Velocity of sound at measurement conditions.....	272
6.2.9	AK Velocity of sound at base conditions .....	272
6.2.10	AM Viscosity.....	272
6.2.11	AN Isentropic exponent.....	272
6.2.12	AO Joule-Thomson coefficient .....	272
<b>6.3</b>	<b>C Analysis .....</b>	<b>274</b>
6.3.1	CA Overview (Analysis function key).....	274
6.3.2	CB Conversion factor .....	275
6.3.3	CC Calculation of K coefficient.....	276
6.3.4	GERG 88 S.....	281
6.3.5	CE AGA NX 19 equation of state .....	283
6.3.6	CH AGA 8 92DC equation of state .....	284
6.3.7	CK Industrial gases parameter .....	285
6.3.8	CN C6+ -Distribution .....	286
<b>6.4</b>	<b>D Calculated values.....</b>	<b>287</b>
6.4.1	DA Calculations according to ISO 6976 .....	287
6.4.2	DB Calculation according to AGA10/Helmholtz ISO20765-1:2005 .....	288
6.4.3	DC Transport phenomena .....	289
6.4.4	DD Critical values .....	289
6.4.5	DE Stoichiometry.....	290

6.4.6	DF Environment.....	291
6.4.7	DJ Exhaust summary .....	292
6.4.8	DK Composition of exhaust fumes .....	294
6.4.9	DG Correction of velocity of sound.....	295
6.4.10	DH Assessed analysis.....	296
6.4.11	DI Adjustable extra base condition .....	297
6.4.12	DL Calculations according to GPA 2172-96.....	297
<b>6.5</b>	<b>E-Z Additional analysis-specific menus .....</b>	<b>298</b>
6.5.1	EB Base values .....	298
6.5.2	EF Processing table values .....	299
6.5.3	FE Calibration unit standard density / gross calorific value.....	300
<b>6.6</b>	<b>Analysis-specific communication.....</b>	<b>301</b>
6.6.1	IG Imported gas quality via DSfG .....	302
6.6.2	IJ Imp. GC Modbus main.....	305
6.6.3	IK Imp. GC Modbus ref.....	306
6.6.4	IL Modbus Master GC1 .....	307
6.6.5	IM Modbus Master GC2 .....	310
6.6.6	IH Imported gas quality via RMG bus.....	311
6.6.7	IP Modbus EGO Erdgas Ostschweiz.....	316
<b>7</b>	<b>OVERVIEW: COORDINATES .....</b>	<b>318</b>
7.1.1	LS Hourly quantities .....	318
<b>7.2</b>	<b>Documentation .....</b>	<b>320</b>
7.2.1	Check numbers .....	320
7.2.2	Matrix.....	321
7.2.3	Document creation .....	322
7.2.4	Documentation .....	323
<b>7.3</b>	<b>Parameterization.....</b>	<b>324</b>
7.3.1	Parameterizing data .....	324
7.3.2	Calibration data .....	325
7.3.3	Changes .....	326
7.3.4	Saving and loading.....	327
<b>7.4</b>	<b>Parameterization help .....</b>	<b>328</b>
7.4.1	Support for inputting components.....	328
<b>7.5</b>	<b>Miscellaneous.....</b>	<b>329</b>
7.5.1	Fault display .....	329
7.5.2	Frozen values.....	329
7.5.3	Interface variables .....	330
7.5.4	View log.....	331
7.5.5	Binary code check.....	332
7.5.6	TSV export.....	333
7.5.7	Exceptions.....	335
<b>8</b>	<b>FAULTS .....</b>	<b>336</b>

<b>8.1</b>	<b>Fault settings .....</b>	<b>336</b>
8.1.1	JA Fault messages .....	336
8.1.2	JB Message register.....	338
8.1.3	CJ GIA-Bit table.....	339
8.1.4	JD Debugging.....	340
8.1.5	ON Extra messages .....	341
<b>8.2</b>	<b>Error table .....</b>	<b>342</b>
 <b>APPENDIX .....</b>		 <b>354</b>
A.1	Second PT100.....	354
A.2	Special case of revision with orifice flow meter .....	356
A.3	Linking extra counter with pulse output .....	357
A.4	Linking control totalizer with pulse output.....	358
A.5	Test functions .....	359
.A.5.1	FA Control panel.....	359
.A.5.2	FB On-the-fly calibration.....	360
.A.5.3	FC Freeze.....	360
.A.5.4	FD Corrector cycle.....	361
.A.5.5	FF Function test under running conditions .....	361
.A.5.6	FG Hardware test .....	363
.A.5.7	FJ File system .....	364
.A.5.8	FK Boole function .....	365
<b>B)</b>	<b>Updating software .....</b>	<b>366</b>
B.1	Advance information.....	366
B.2	Software identification .....	367
B.3	Updating software.....	368
B.4	Installing BIOS.....	371
B.5	Activation after software update .....	373
<b>C)</b>	<b>Archive assignment, depth and identification .....</b>	<b>374</b>
C.1	Archive groups.....	374
.C.1.1	OA DSfG archive .....	375
.C.1.2	OC Function .....	376
.C.1.3	OD Input values.....	376
.C.1.4	OE Miscellaneous.....	377
.C.1.5	OU Freely programmable archive .....	378
.C.1.6	OV Dialogs .....	379
.C.1.7	OW Text for Browser .....	380
.C.1.8	OY special values DSfG .....	381
.C.1.9	OZ DSfG archive part 2.....	382
.C.1.10	Archive groups.....	382
C.2	Archive depth.....	384
C.3	Archive identifications.....	384
<b>D)</b>	<b>Determination of the correction factor for a current input.....</b>	<b>385</b>
<b>E)</b>	<b>Various circuit diagrams for inputs .....</b>	<b>386</b>
<b>F)</b>	<b>Optional Ex input board .....</b>	<b>397</b>
F.1	Instructions for the installer.....	397



<b>G)</b>	<b>Various circuit diagrams for outputs</b> .....	<b>399</b>
<b>H)</b>	<b>Vo digital totalizer</b> .....	<b>400</b>
<b>I)</b>	<b>Examples for use of the revision switch</b> .....	<b>402</b>
<b>J)</b>	<b>Appendix for bus systems</b> .....	<b>405</b>
	J.1 DSfG bus .....	405
	.J.1.1 Literature for the DSfG bus.....	405
	.J.1.2 Cross-comparison via DSfG .....	405
	J.2 Modbus.....	408
	.J.2.1 Summarized fault messages .....	408
	.J.2.2 Modbus EGO.....	413
	.J.2.3 Transgas Modbus.....	415
	.J.2.4 Eon gas transport Modbus .....	417
<b>K)</b>	<b>Cross-references to coordinates</b> .....	<b>418</b>
	K.1 A Measurements .....	418
	K.2 B Components.....	420
	K.3 C Analysis.....	422
	K.4 D Calculation values.....	423
	K.5 E Mode .....	424
	K.6 F Test .....	425
	K.7 G Totalizer/volume transmitter .....	426
	K.8 H Flow rate .....	427
	K.9 I Communication.....	428
	K.10 J Fault messages .....	429
	K.11 K Times .....	429
	K.12 L Totalizers .....	430
	K.13 M Outputs .....	432
	K.14 N Inputs .....	434
	K.15 O Miscellaneous .....	436
	K.16 P Highest load .....	438
	K.17 Q Archive.....	439
	K.18 T Trend.....	441
	K.19 U IGM .....	442
	K.20 V F instance.....	444
	<b>CERTIFICATES</b> .....	<b>445</b>



# 1 About this manual

## 1.1 Structure of the manual

The first chapter of this manual essentially comprises four parts. Safety-relevant general specifications are provided in the first part. They must be observed for safe operation. The symbols used in the manual and the structure of notices are presented and a risk assessment is also provided. The second part describes the function before the basic overview of the configuration is presented in the third part. The fourth part describes the different device types that are used for various applications. In general, the device comes pre-configured and sealed for the previously intended application. For this reason, the fourth part also includes the complete seal diagram. Signed data that the ERZ2000-NG can be sent has been included as a final subsection.

The second chapter covers the operation of the ERZ2000-NG. Complete operation is possible via the touchscreen of the device; the various screens and their functions are presented. Operation of the ERZ2000-NG via a browser is convenient after connection to a PC.

The electrical connections and their configuration are presented in the third chapter. The chapter also outlines how inspections and corrections can be carried out, when applicable. More extensive measurement values and data are transferred via various buses, usually in digital form; for more information, refer to the fourth chapter.

Pressure and temperature measurement transmitters are described in the fifth chapter. Flow meters have been removed from this chapter and are summarized in the sixth chapter; transmitters for gas data are in the seventh chapter.

The ERZ2000-NG stores a host of information for documentation and assistance in parameterization, etc. It is provided in the eighth chapter.

The final chapter provides a list of errors and error annotations.

The annex includes the description of special cases, various connection diagrams for inputs and outputs and test function to ensure safe operation of the ERZ2000-NG with its connected components. It also provides further details about the archives. Connection and operation of the optional Ex input board are defined here.

Cross-references to all menu items of the ERZ2000-NG are provided for further information about the various menus. A key word index is provided before a summary of current approvals at the end of the manual.

**Note**

The PDF file contains some functionalities:

1. By clicking on the individual sections in the table of contents, you can skip directly to the corresponding chapter.
2. The manual contains numerous cross-references which can also be used to skip to these chapters.
3. All menu items of the ERZ2000-NG are listed in the last chapter of the annex; the cross-references there also make it possible to skip to the corresponding passages.

2

## 1.2 Purpose of the manual

This manual provides information that is necessary for fault-free and safe operation.

The ERZ2000-NG was designed and produced according to the state of the art and generally recognized safety standards and directives. However, its use can entail dangers that are avoidable by complying with this manual. The device must only be used as intended and in technically sound condition.

**Caution**

Unintended use voids all warranty claims and the flow computer ERZ2000-NG can also lose its approvals.

### 1.2.1 Abbreviations

The following abbreviations are used:

ca.	circa, about
max.	maximum
min.	minimum
e.g.	for example
MID	Measurement Instruments Directive
PED (DGRL)	Pressure Equipment Directive (Druckgeräterichtlinie)
DSfG	Digitale Schnittstelle für Gasmessgeräte Digital interface for gas flow rate meters, created under the umbrella of the DVGW

DVGW	Deutscher Verein des Gas- und Wasserfaches German Gas and Water Association
MessEG	Measuring and calibration law Law on placing and providing measuring instruments on the market, their use and calibration; valid since 1.1.2015
MessEV	Measuring and calibration regulations Regulation on placing and providing measuring instruments on the market; their use and verification; 11.12.2014
TCP/IP	Transmission Control Protocol/Internet Protocol
IP (-Adresse)	Address assigned to devices based on the Internet Protocol (IP). This makes devices addressable and accessible in the network.
LAN	LAN (Local Area Network) is a local or local network, a computer network.
Eth1 / Eth2	Ethernet interface 1 /2 Ethernet technology enables data to be exchanged in the local network between the connected devices.
SNTP	Simple standard (NTP = Network Time Protocol) to synchronisierung von Uhren in Computersystemen
PTB	Physikalisch-Technische Bundesanstalt German authority for calibration tasks
SNR	Signal to Noise Ratio
VOS or SoS	Speed (Velocity) of Sound
TD	Transducer (ultrasonic transmitter and receiver)
USM (USZ)	Ultrasonic gas meter
Vo	Digital interface, original counter of an encoder (ENCO)
HART	Highway Addressable Remote Transducer Protocol Standardized, digital communication superimposed on the 4..20 mA analog Signal for data exchange with encoder devices

The following registered trademarks are used in the text:

Windows, Windows®, Windows CE, Explorer () , Firefox () ,

## 1.2.2 Symbols

The following symbols are used:

1, 2, ...	Identifies steps for work tasks
..	

4

## 1.2.3 Structure of notices

The following notices are used:

<b>⚠ Danger</b>
This warning notice informs you of imminently threatening dangers that can arise due to misuse/operator error. If these situations are not avoided, death or severe injuries can occur.

<b>⚠ warning</b>
This warning notice informs you of potentially dangerous situations that can arise due to misuse/operator error. If these situations are not avoided, minor injuries can occur.

<b>⚠ Caution</b>
This notice informs you of potentially dangerous situations that can arise due to misuse/operator error. If these situations are not avoided, damage to the device or nearby property can occur.

<b>Note</b>
This notice provides you with helpful tips to make your work easier. This notice also provides you with further information about the device or the work process in order to prevent operator error.

**1.2.4 Working with the device**

**1.2.4.1 Safety instructions**

<b>⚠ Danger</b>
<b>All of the following safety notices must be observed!</b>

5

---



---



---

Disregard of the safety notices can result in danger to the life and limb or environmental and property damage.

Bear in mind that the safety warnings in this manual and on the device cannot cover all potentially dangerous situations, because the interaction of various conditions can be impossible to foresee. Merely following the instructions may not suffice for correct operation. Always remain attentive and consider potential consequences.

- Read this operating manual and especially the following safety notices carefully before working with the device for the first time.
- Warnings are provided in the operating manual for unavoidable residual risks for users, third parties, equipment or other property. The safety instructions used in this manual do not refer to unavoidable residual risks.
- Only operate the device in fault-free condition and in observance of the operating manual.
- Compliance with local statutory accident prevention, installation and assembly regulations is also mandatory.

<b>⚠ Caution</b>
<p><b>All notices in the manual must be observed.</b></p> <p><b>Use of the flow computer ERZ2000-NG is only permitted in accordance with the specifications in the operating manual.</b></p> <p><b>RMG assumes no liability for damages arising due to disregard of the operating manual.</b></p>

<b>⚠ Danger</b>
<b>Service and maintenance tasks or repairs that are not described in the operating manual must not be carried out without prior consultation with the manufacturer.</b>

**Note**

The flow computer ERZ2000-NG is approved for officially certified operation. For this purpose, it is sealed before deliver and settings specified by the approval authority are blocked.

These seals, software or hardware locks must not be damaged, destroyed or removed!

In this case, the ERZ2000-NG loses its official certification!

The ERZ2000-NG can only be approved for officially certified operation after a renewed inspection by calibration officials and an additional inspection of additional settings in the factory.

The calibration official must re-apply the seals and blockades.

Observe the following, in particular:

- Modifications of the flow computer ERZ2000-NG are not permitted.
- The technical specifications must be observed and followed for safe operation (*chapter 2.7 Electrical connections*). Performance limits must not be exceeded.
- The flow computer ERZ2000-NG must only be used in the scope of the intended use (*chapter 1.5 Areas of application*)
- The flow computer ERZ2000-NG complies with current standards and regulations. However, danger can arise with misuse.

#### 1.2.4.2 Dangers during commissioning

Initial commissioning

The initial commissioning must only be carried out by specially trained personnel (training by RMG) or RMG service personnel.



**Note**


In accordance with Article 15 of the German Ordinance on Industrial Safety and Health (BetrSichV), Article 5 of German Social Accident Insurance (DGUV) REGULATION 3 "Electrical systems and equipment" and generally recognized good engineering practices, particularly the VDE standards VDE 0100-100 "Construction of low-voltage systems" and VDE 0165 "Electrical explosion protection", an inspection of the measuring system must be carried out before the device is commissioned.

An acceptance test certificate must be created during the commissioning. This, the operating manual and the CE Declaration of Conformity must be stored so that they are always readily available. In the process, the entire documentation, including the conformity declarations and certificates must be checked for completeness.

All sharp edges on the device were removed, insofar as possible. However, suitable personal protective equipment provided by the operator must be worn during all work.

7

**⚠ Danger**

 This symbol is used in the manual as a warning of the danger of explosion; observe the instructions following the symbol. With the danger of explosion, the following must be observed, in particular:

The flow computer ERZ2000-NG is **not** approved or designed for use in explosion-prone areas. Installation must only take place in safe rooms. The ERZ2000-NG is intended for installation in a control cabinet in an electronics room.

Install the device as specified in the operating manual. If the device is not installed as specified in the operating manual, there may be a risk that other connected devices have adequate explosion protection.

Inadequately qualified persons working on the equipment are unable to correctly estimate dangers. Explosions can be triggered. Only work on the equipment if you have the appropriate qualifications.

Components can be damaged if you do not use suitable tools and materials. Only use tools that are recommended for the respective work in the operating manual.

Mechanical installation

Mechanical installation must only be performed by appropriately qualified technicians.

Electrical installation	Installation on electrical components must only be carried out by qualified electricians.
Mechanical and/or electrical installation	These qualified personnel require training specifically for work in explosion-prone areas. Qualified personnel are persons who have training / education in accordance with <b>DIN VDE 0105, IEC 364</b> or <b>comparable standards</b> .

### **Caution**

**In general, the replacement of a flow computer ERZ2000-NG must only be carried out by RMG Service.**

#### 1.2.4.3 Dangers during maintenance and repair

Operating personnel	The operating personnel use and operate the device in the scope of the intended use.
Maintenance personnel	Work on the device must only be carried out by qualified personnel who can carry out the respective tasks on the basis of their technical training, experience and familiarity with the applicable standards and requirements. These qualified personnel are familiar with the applicable statutory regulations for accident prevention and can independently recognize and avoid potential dangers.
Maintenance and cleaning	Maintenance and cleaning must only be performed by appropriately qualified technicians.

### **Danger**

**Inadequately qualified persons working on the equipment are unable to correctly estimate dangers. Explosions can be triggered.**

### **Caution**

**The device can be damaged if it is not cleaned as specified in the operating manual. Only clean the device as specified in the operating manual.**

- **Only clean the device with a slightly damp cloth!**

**⚠ Danger**

The flow computer ERZ2000-NG must only be used as intended! (*chapter 1.5 Areas of application*).

Avoid using the flow computer ERZ2000-NG as a potential climbing aid or as a potential grip!

9

#### 1.2.4.4 Qualification of personnel

**Note**

In general, the following is recommended for all persons working with or on the flow computer ERZ2000-NG:

- Training / education for work in explosion-prone areas.
- The capacity to be able to correctly estimate dangers and risks when working with the flow computer ERZ2000-NG and all connected devices.
- Training / education by RMG for work with gas measuring devices.
- Education / instruction in all national standards and directives to be complied with for the work to be carried out on the flow computer ERZ2000-NG.

#### 1.2.5 Risk assessment and minimization

According to assessment by qualified employees of RMG, the flow computer ERZ2000-NG is subject to risks during its use. Risks can arise, for instance, during use outside of the permissible temperature range. Impermissible current and voltage values can trigger explosions in explosion-prone areas. Naturally, work must only be carried out by trained personnel (see *chapter 1.5 Areas of application*), who are also trained to recognize suitable tools and use them exclusively. These risks were summarized alongside development and measures were taken to minimize these risks.

**Measures for risk minimization:**

- The maximum permissible temperature range is specified on the type plate of the flow computer ERZ2000-NG. Operation of the device is only permitted within these specified ranges.

**⚠ Danger**

- The wiring from and installation of the flow computer ERZ2000-NG in explosion-prone areas must only be carried out by trained personnel in accordance with EN60079-14 and in observance of national regulations.
- Qualified persons must satisfy the definitions in accordance with DIN EN 0105 or IEC 364 or directly comparable standards.
- Only trained and instructed personnel are permitted. Work on the measuring system must only be carried out from qualified persons and inspected by responsible qualified supervisors.
- Qualified persons have been authorized by the person responsible for safety of personnel to carrying out such work on the basis of their training, experience or instruction and familiarity with applicable standards, provisions, accident prevention regulations and system conditions. It is essential that these persons are able to recognize and avoid potential dangers in good time.

### 1.2.6 Applicability of the manual

This manual describes the volume corrector ERZ2000-NG. The ERZ2000-NG is only part of a complete system. The manuals of the other components of the system must be observed. If you find contradictory instructions, contact RMG and/or the manufacturers of the other components.

**⚠ Caution**


Ensure that the power data of the current connection matches the specifications on the type plate. Observe any applicable national regulations in the country of use. Use cable that is appropriate for the cable fittings.

#### 1.2.6.1 Danger during operation

Observe the specifications of the system manufacturer and/or system operator.

**1.2.6.2 Dangers of operation in Ex areas**

The flow computer ERZ2000-NG is **not** intended for use in explosion-prone areas.

 <b>Danger</b>	<ul style="list-style-type: none"> <li>• <b>The flow computer ERZ2000-NG must be used exclusively in fault-free and complete, original condition. If you make technical changes to the device, safe operation can no longer be guaranteed.</b></li> <li>• <b>Ensure that the appropriate explosion protection is provided for the connection of all sensors or other devices that are used in explosion-prone areas!</b></li> <li>• <b>If they are intrinsically safe devices, galvanic isolation must be provided with connection of these devices!</b></li> </ul>
---	---

11

**1.2.6.3 Responsibility of the operator**

As the operator, you must ensure that only adequately qualified personnel work on the device. Ensure that all employees who work with the device have read and understood this manual. You are also obligated to train personnel regularly and inform them of the dangers. Ensure that all work on the device is carried out exclusively by qualified persons and inspected by responsible qualified supervisors. The responsibilities for installation, operation, fault rectification, maintenance and cleaning must be clearly regulated. Instruct your personnel with regard to the risks involved with working with the device.

**1.2.7 Transport**

The device is packaged specific to the transport requirements for each customer. Ensure safe packaging that absorbs light impact and vibrations is used for any further transport. Nevertheless, inform the transport company that all types of impact and vibrations should be avoided during transport.

**1.2.8 Scope of delivery**

The scope of delivery can differ depending on the optional orders. The following is "normally" included in the scope of delivery:

Part	Quantity
ERZ2000-NG	1
Socket set 98800-15700	1
Manual	1

### 1.2.9 Disposal of packaging material

Dispose of the material in an environmentally friendly manner in accordance with national standards and directives.

### 1.2.10 Storage

Avoid extended periods of storage. After storage, inspect the device for damage and test for correct function. Contact the RMG service department to arrange for inspection of the device after a storage period of longer than one year. For this purpose, send the device to RMG.

#### Note

**Even if the ERZ2000-NG is stored for a short time only, it is important to ensure a clean and dry environment!**

#### **Danger**

**Life-threatening danger due to damages occurring during storage.**

**If the device is stored for a period of more than one year, deficient repacking or securing of the device can result in damage to the device from dirt or moisture.**

**A defective device can cause an explosion in explosion-prone areas.**

**There is also a risk of poisoning!**

### 1.3 Function

The volume corrector ERZ2000-NG is designed to operate various sensors, particularly flow rate and gas analysis sensors, evaluate their signals or adopt and determine resulting operating and nominal volume flows. The resulting billing variables can be represented in a graph and checked via alarm output, etc. The ERZ2000-NG corresponds to the standards, directives and specifications listed in *chapter 1.5 Areas of application*. *Figure 1* explains the functional principle.

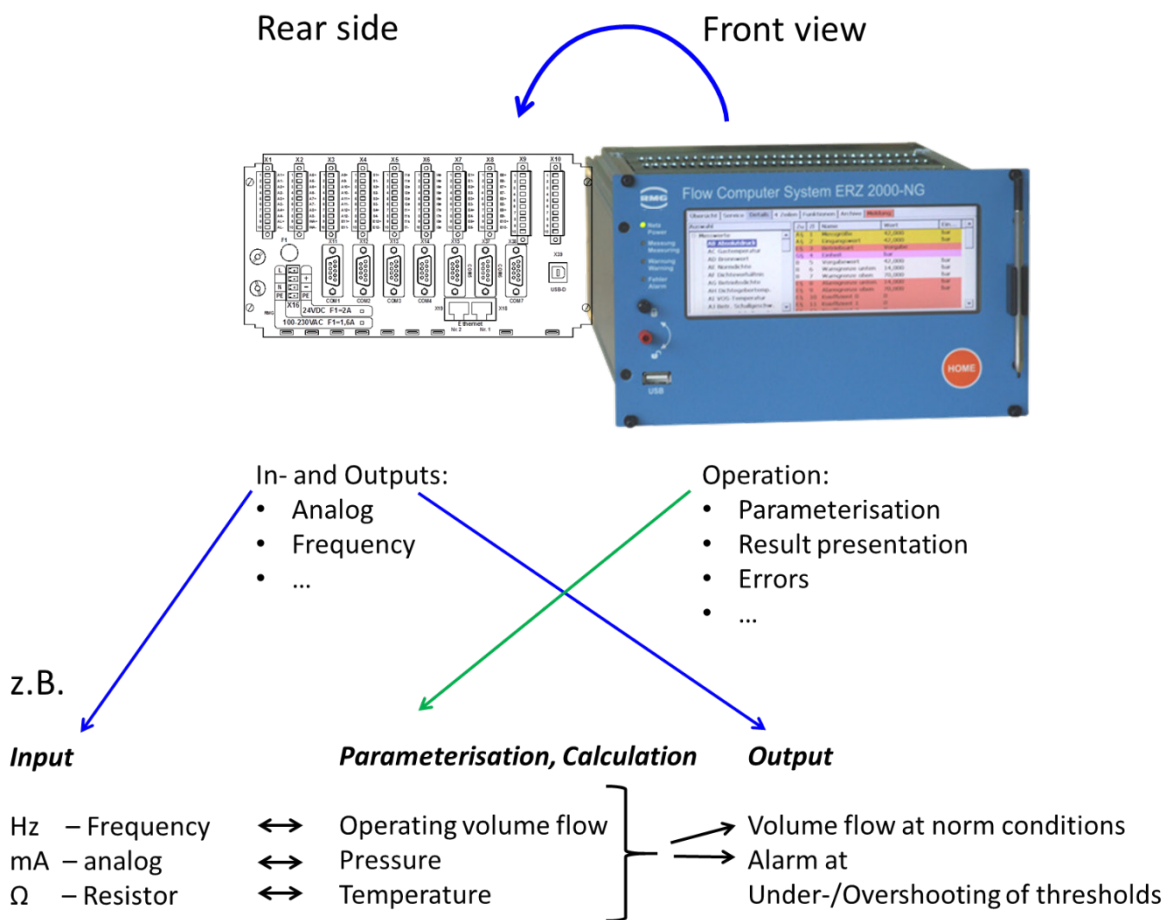
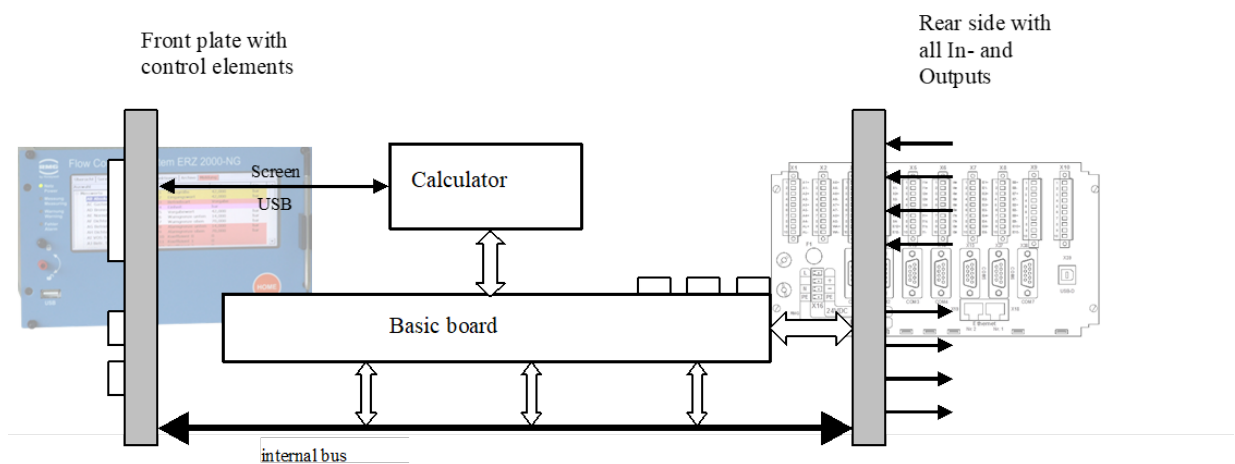


Figure 1: Functional principle

It is important that the ERZ2000-NG both adopts "finished" values (e.g. pressure, temperature, etc.) from the sensors and can, in part, processes "raw signals" of the individual sensors and then recalculate them (e.g. the pressures at the orifice flow meter are converted to a volume flow, etc.).

## 1.4 Overview

The ERZ2000-NG, therefore, is an advancement of the ERZ2000 as a half 19" slide-in module (half 19" width). The ERZ2000-NG system has a configuration consisting of 2 function groups with a clear separation between the functions of measurement value determination, quantity conversion, registration and basic tasks. The first function group, the **basic assembly**, provides the quick measurement recording, all inputs and outputs, all interfaces and manual operation via the front panel or via the wizard.



**Figure 2: System configuration overview**

The high measuring accuracy in the quantity calculation is implemented with the basic assembly. All accuracy-relevant parameters are assigned to this assembly and are stored here. This assembly thus determines the accuracy of the inputs and outputs, their temperature curve and thus the accuracy of the overall device. The digital data interfaces are also provided on the basic assembly. These interfaces can be used as a service interface, as a DSfG bus system in accordance with the current specifications for flow computers and registry instance, as a DSfG control station, as a Modbus for external data transmission, as Ethernet TCP/IP network connections and as a connection for an external modem.

The basic assembly is designed for measurement and recording of all inputs; no calculations or assignments to physical variables take place. The basic assembly contains analogue values, frequencies and totalizer content only - without assigning meaning to the individual values.

These measurements are transmitted to the computing unit in which they are assigned to physical variables and can be converted into practical data. All outputs and data interfaces are also operated from the basic group. An additional task is the reading of controls on the front panel and the display of measurements and parameters on the display. There are three reserve slots for hardware extensions.



The actual calculations and conversion functions are processed by the second assembly, the computing unit. This is an "embedded" PC with a powerful computing unit consisting of a high-performance microprocessor system with corresponding program memory (flash), working memory and data buffer. Therefore, the ERZ2000-NG can also perform more complex calculations with very short computing times.

The working memory contains the variables, fields, buffers, etc. necessary for the processing of the system software, as well as the (variable) device parameters of all function assemblies. The device parameters are saved with a checksum that is checked automatically each time the device is restarted.

The program memory contains the operating program of the device. A CRC checksum is calculated via the source and stored as a reference value. The correctness of the checksum can be checked for the software ID in the coordinates of the menu **EJ Software ID** with the specifications on the type plate (*chapter „2.5.3 Details" and chapter "2.5.5 Functions" – type plate*).

15

## 1.5 Areas of application

The **essential area of application** is the **recording and metering of flow rates for custody transfer in natural gas flow measurement technology**. However, there are also equation systems available to detect, for example, pure industrial gases. The device can be provided in the version of the software as:

- Status flow computer for natural gas  
Compressibility factor calculation in accordance with GERG 88 S, AGA NX 19 or AGA 8 92DC
- Combustion flow computer for natural gas  
Compressibility factor calculation in accordance with GERG 88 S, AGA NX 19 or AGA 8 92DC
- Status flow computer and mass computer for pure gases  
Compressibility factor calculation according to the Beattie Bridgeman equation for: hydrogen, nitrogen, oxygen, ammonia, carbon dioxide, helium, neon, argon, methane, krypton, xenon, ethane, ethylene, acetylene, propane and butane.

Other equations can also be used (see *chapter: 6 Parameter of the gas*)

The device concept is provided for extension and integration of all individual devices of older series from RMG Messtechnik GmbH as a universal system.

### 1.5.1 Device type adjustment

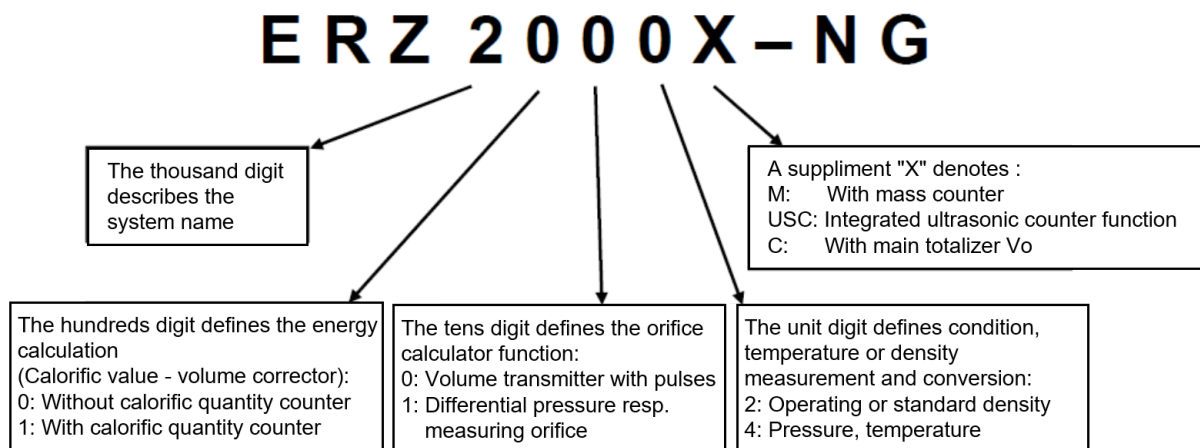
#### Note

If the device is used for custody transfer, a switchover is blocked!

In this case, only the device type according to the factory settings matching the type plate affixed on the front panel can be operated.

Modification of the device type is only possible in the factory under the supervision and control of an officially recognized inspection authority or calibration official. Said authority will apply the necessary seals and blockades after the modification.

#### Designations and device variants of the ERZ2000-NG system family



#### Device type switchover

Normally, a special factory setting is used for custody transfer applications. The device cannot be used for custody transfer without this special setting. The "Super user" and "Open calibration switch" (*chapter 2.3 Access protection for data and settings*) enable the device type switchover with change of **coordinate EB19** (*chapter 2.5.3 Details*). Available options:

Volume corrector (VC)	ERZ2004
Calorific value corrector (CVC)	ERZ2104
Density corrector (DC)	ERZ2002
Energy density corrector (EDC)	ERZ2102
Special case: VC with main totalizer Vo	ERZ2000C

VC with ultrasonic controller (USC)	ERZ2004 USC	
CVC with USC	ERZ2104 USC	
DC with USC	ERZ2002 USC	
EDC with USC	ERZ2102 USC	
VC with USC and mass calculation (MC)	ERZ2004M USC	
CVC with USC and MC	ERZ2104M USC	17
DC with USC and MC	ERZ2002M USC	
EDC with USC and MC	ERZ2102M USC	
VC with MC	ERZ2004M	
CVC with MC	ERZ2104M	
DC with MC	ERZ2002M	
EDC with MC	ERZ2102M	
VC for orifice plate flow computer	ERZ2014	
CVC for orifice plate flow computer	ERZ2114	
DC for orifice plate flow computer	ERZ2012	
EDC for energy orifice plate flow computer	ERZ2112	
VC for orifice plate flow computer with MC	ERZ2014M	
CVC for orifice plate flow computer with MC	ERZ2114M	
DC for orifice plate flow computer with MC	ERZ2012M	
EDC for orifice plate flow computer with MC	ERZ2112M	

**Comment:** The abbreviations

VC	=	volume corrector
CVC	=	calorific value corrector
DC	=	density corrector
EDC	=	energy density corrector
USC	=	ultrasonic controller
and MC	=	mass calculation

apply here only and are not general abbreviations.

### 1.5.2 Use in gas measurement technology

The ERZ2000-NG is not intended for use in explosion-prone areas. However, it can operate sensors and other devices in explosion-prone areas.

Only operate the ERZ2000-NG in fault-free and complete condition.

If you make technical changes to the device, safe operation can no longer be guaranteed.

### **Danger**

- Only use the ERZ2000-NG in its original condition.
- When connecting sensors and other devices in explosion-prone areas, ensure that the appropriate explosion protection is provided for these components. The specified maximum values in the certificates issued for these components must be observed.
- They are intrinsically safe devices for which galvanic isolation must be provided with connection of these devices.
- Life-threatening danger due to incorrect earthing. If the device is not earthed correctly, so that electrostatic charges can trigger the formation of sparks, there is a risk of explosion.

### **Note**

The ERZ2000-NG system is approved in different variants for custody-transfer application for gas measurement technology in Germany and other countries. The following EU type examination certificates are available for Germany (see Appendix Approvals):

ERZ2000-NG	<b>Maximum load display and registering device</b> (DE-16-M-PTB-0027, Revision 1)
ERZ2004	<b>MID Approval (Status flow computer)</b> (DE-13-MI002-PTB-003, Revision 4)
ERZ2104	<b>Calorific value flow computer</b> (DE-16-M-PTB-0026, Revision 1)
ERZ2014 / ERZ2114	<b>Differential pressure gas meter</b> (DE-16-M-PTB-0028, Revision 1)

**A type approval certificate in accordance with Directive 2004/22/EC (MID), Module B is available for the territory of the European Union:**

ERZ2004	<b>pTZ-Volume Conversion Device acc. to EN 12405-1</b> (Certificate no. DE-13-MI002-PTB003 4th revision)
ERZ2104	<b>pTZ-Volume Conversion Device acc. to EN 12405-1</b>

**with Additional Function Energy Conversion Device acc. to EN 12405-2**  
(Certificate no. DE-13-MI002-PTB003 4th revision) \*)

\*) The function of the calorific value conversion in the ERZ2104 (calculation of energy and energy totalizers in each totalizer unit) is an integrated function in the sense of MID, but is not subject to MID. However, it was tested in the scope of the national approval process for the ERZ2104.

19

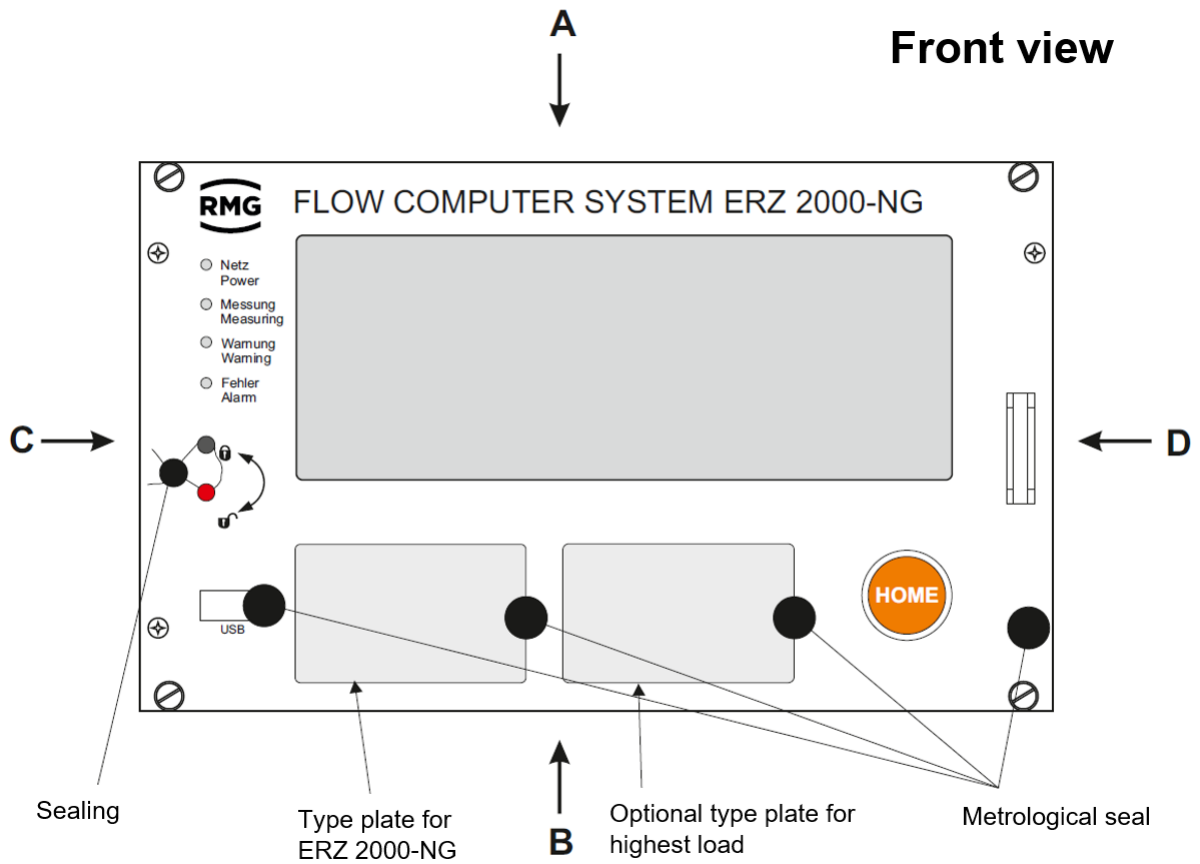
The applicable approval (approval symbol) is specified on the type plate (*chapter "2.5.5 Functions" – "Type plate"*). The corresponding seal diagrams can be found in this manual or the approval (*chapter 1.5.3 Seal diagram*).

If a temperature transmitter for the ERZ2004 or ERZ2104 types approved in accordance with MID, it must be secured as follows:

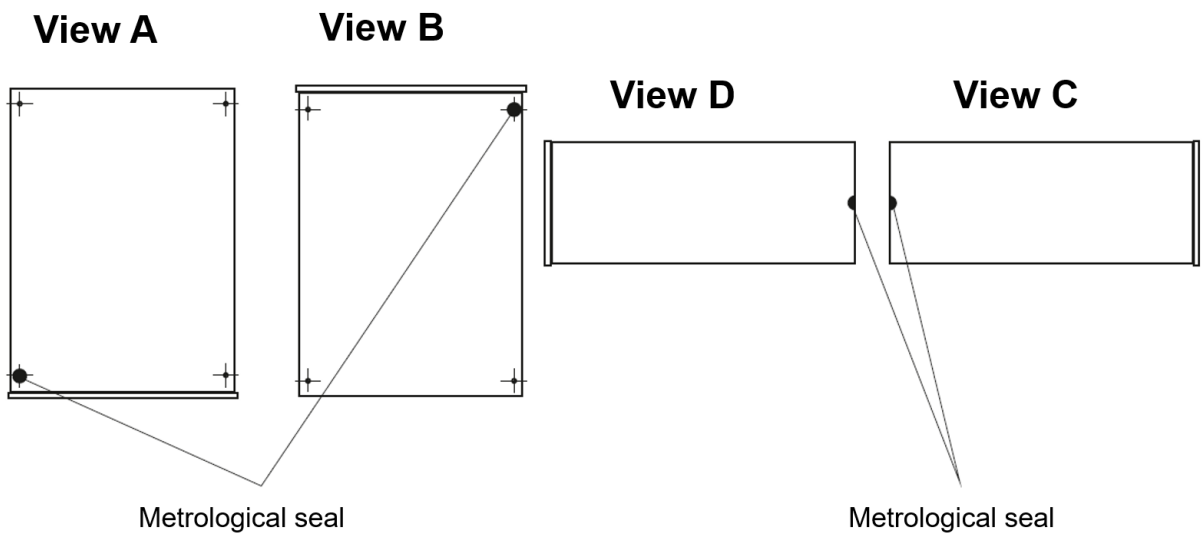
- The main plate is provided with a sealing label.
- Access to the calibration switch, which is set to "write protect" during normal operation, is secured by connecting the removable cover of the electronic housing with sealing marks with the stationary parts of the housing.

### 1.5.3 Seal diagram for devices with MID approval

Normally, the ERZ2XXX-NG leaves the factory with the setting agreed upon with the customer, which is protected from "significant" changes by seals for custody transfer applications. *Figure 3: Seal diagram - front* and *Figure 5: Seal diagram - rear* show the specified positions of the seals.



**Figure 3: Seal diagram - front**



**Figure 4: Seal diagram - sides A, B, C, D**

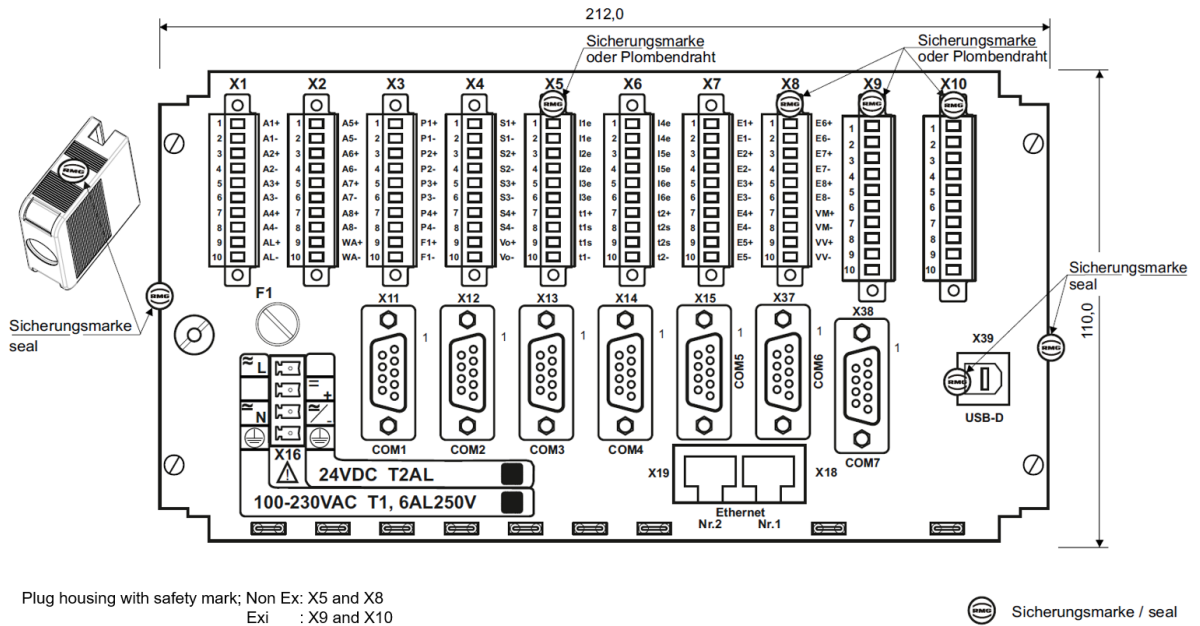


Figure 5: Seal diagram - rear

**Note**

The ERZ2000-NG is also supplied with a connector set (see above *chapter 1.2.8 Scope of delivery*).

In particular, terminals X5 and X8 (if necessary also X9 and X10) must be used to fasten the enclosed socket shells, which must be sealed by the calibration officer after adjustment and commissioning.

These seals are applied by a calibration official and must be broken and re-applied strictly by said official.

**⚠ Caution**

Removal or seals normally entails considerable expenses!

The ERZ2000-NG and its operation lose any approval for custody transfer applications immediately when a seal is broken!

Re-application of seals must only be carried out by calibration officials!

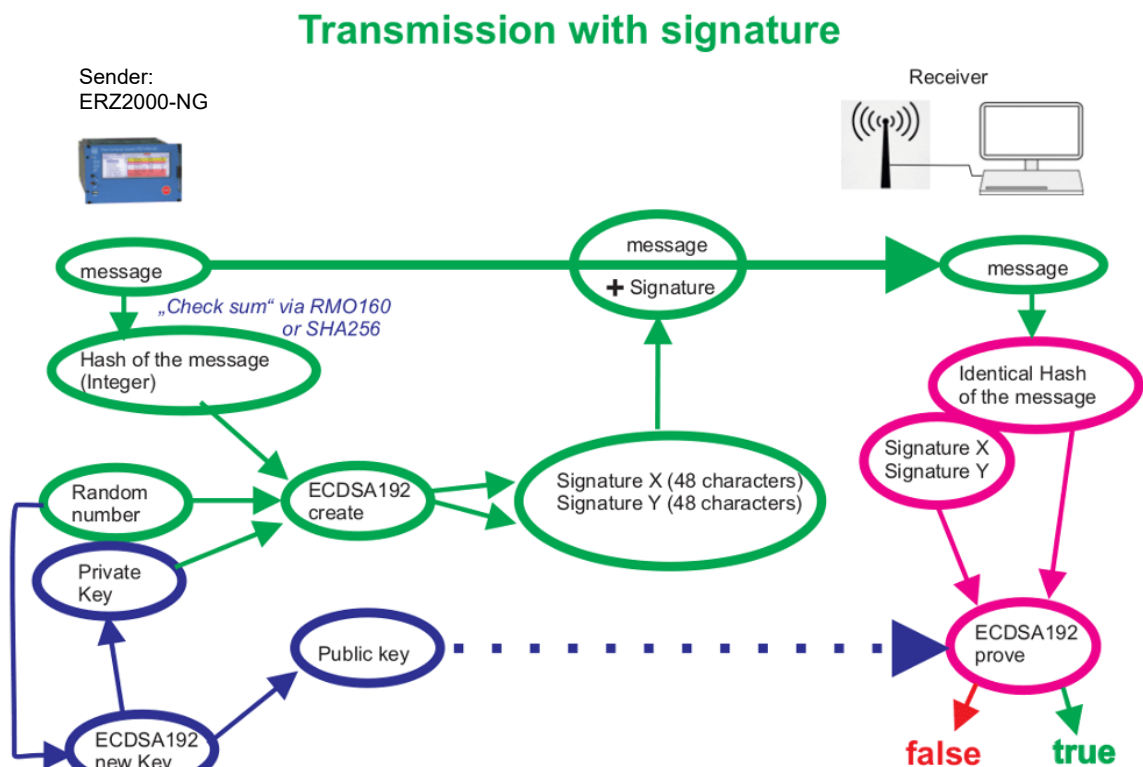
### 1.5.4 Signature, software and hardware data

The ERZ2000-NG offers the option of marking recorded data with an accompanying signature. In the process, the data is not encrypted, but the signature makes it possible to determine whether the data originated from a "secure" source and whether the data quantity was manipulated.

The following figures *Figure 6: "Normal" data transmission* and *Figure 7: Signed data transmission* clarify the process.



**Figure 6: "Normal" data transmission**



**Figure 7: Signed data transmission**



With "normal" data transmission, the data is sent by a transmitter to the receiver, which can process said data. In the process, the data must not be considered as trustworthy and any potential data manipulation cannot be checked.

The process for a signed data transmission is somewhat more complicated. There are essentially 3 processes.

1. A program, ECDSA192 (**E**lliptic **C**urve **D**igital **S**ignature **A**lgorithm) in the ERZ2000-NG generates 2 keys after a random number is loaded: a private key and a public key. These keys consist of 2 parts, signature X and signature Y, wherein each part consists of 48 hexadecimal characters ( $4 \times 48 = 192$ ; thus ECDSA192).

The private key is stored inaccessibly inside the ERZ2000-NG.

**Note**

**This key cannot be read or changed in the sealed state of the ERZ2000-NG.**

The public key is, for example, can be read in the **Parameterization** menu, submenu **Parameter data** under **ER Signature** in the coordinates

**ER05 public key Qx (first 40 characters),  
ER06 public key Qx (additional characters),  
ER05 public key Qy (first 40 characters) and  
ER05 public key Qy (additional characters),**

(Although the key can also be read in the **ER Signature** menu, it is not usually complete.)

The recipient requires this public key in order to be able to identify the data.

2. A hash is formed from the data of the message (either RMD160 or SHA256; see below, a type of checksum), which is entered as an integer in Process 2. The signature (signature X and signature Y), which is attached to the message, is calculated with the private key and a random number.
3. The recipient receives the message and the signature. The hash tag can be calculated from the message. The recipient can verify from the public key and signature whether or not the data is unchanged and originates from a "secure" source, i.e. from a trustworthy sender or whether this is not the case.

The generation of the key is not described in detail here. This signing is initiated in the **ER Signature** menu.

## ER Signature

Access Line	Designation	Value	Unit	Variable
E *	1	Method of signature	RMD160+ECDSA192 ▾	<a href="#">signatur</a>
E *	2	Senders ID	Absendertypenschild	<a href="#">AbseTyps</a>
X	3	build new key	No ▾	<a href="#">bldKey</a>
J	4	time stamp (UTC)	28-04-2017 13:27:16	<a href="#">keytime</a>
J	5	Public Key Qx1	41E3EB040B6870F878..	hex <a href="#">pubKeyX1</a>
J	6	Public Key Qx2	7FDCD50C	hex <a href="#">pubKeyX2</a>
J	7	Public Key Qy1	2CF5460F4B9122D7B3..	hex <a href="#">pubKeyY1</a>
J	8	Public Key Qy2	2DE6C389	hex <a href="#">pubKeyY2</a>

**Figure 8: ER Signature menu**

### Note

Access to the coordinates ER01 Signing and ER03 New key is under calibration protection and they can only be initiated or changed with an open calibration switch.

The signing method is selected in the coordinate **ER01 Signature**.

- No signing "no"
- Short signing code "RMD160+ECDSA192"
- Long signing code "SHA256+ECDSA192"

### Note

The DVGW (see *chapter 1.2.1 Abbreviations*) recommends using the RMD160 method for custody transfer applications.

A new key is generated in the coordinate **ER03 New key**.

Generation of a new key is generally recommended when the ERZ2000-NG is left unsupervised with an open calibration switch for an extended time, e.g. during repairs.

**Note**  
 The public keys Qx and Qy and the signature procedure are part of the software type plate. Here you can also read the keys completely.

A *	37	Signature	Method of signature RMD160+ECDSA192 time stamp (UTC) 28-04-2017 13:27:16	<a href="#">sign1Typs</a>
A *	38	Public key Qx	Public Key Qx 41E3EB040B6870F8787B 13CAB50F23264ACA2262 7FDCD50C	<a href="#">sign2Typs</a>
A *	39	Public key Qy	Public Key Qy 2CF5460F4B9122D7B3E6 AA2B3724B1CB8D82A834 2DE6C389	<a href="#">sign3Typs</a>

Enter   Cancel   Load defaults   Refresh

**Figure 9: Signature part of the menu EG type plate**

If the ERZ2000-NG is operated via browser, this can easily be realized via "Copy and Paste". The keys are displayed with

20 characters / 20 characters / 8 characters

instead of

16 characters / 16 characters / 16 characters

in the lower lines so that you can copy all 3 lines with one action to completely copy the key.

Who needs the key DSfG-compliant (see *chapter 1.2.1 Abbreviations*), i.e. works with 40 characters per string, first copies the first two lines and then the third (separately).

If the public key still must be generated, then these fields are empty. If the ERZ2000-NG is only enabled for "user", then the key is hidden in the display of the signature type plate if ER01 Signing is set to "no".

## Software and hardware identification

### EJ Identification of software

Access Line	Designation	Value	Unit	Variable
A *	1	Vers.offic.kernel	1.8	<a href="#">versionEK</a>
A *	2	Checks.offic.kernel	C075	hex <a href="#">chksEK</a>
A *	3	Time offic.kernel	16-09-2019 15:14:47	<a href="#">lchgEK</a>
D	4	Version application	1.8.0g	<a href="#">versionAP</a>
D	5	Checks. application	F0CD	hex <a href="#">chksAP</a>
D	6	Time stamp appl.	16-09-2019 15:16:39	<a href="#">lchgAP</a>
J	7	Version FC BIOS	2.008	<a href="#">versionFCB</a>
J	8	Checks. FC BIOS	5AB5	hex <a href="#">chksFCB</a>
J	9	Time stamp FC BIOS	21-10-2014 15:03:38	<a href="#">lchgFCB</a>
E *	10	Activation key	33587820	<a href="#">schluesel</a>
A *	11	checksum parameter	8433	<a href="#">paramChks</a>
D	12	CRC of binary code	6A5B	hex <a href="#">chksBin</a>
D	13	code controls	2021	<a href="#">codeCtrls</a>
A *	14	MID permission	PTB	<a href="#">MIDzulass</a>
D	16	SVN revisions	1317_201_368	<a href="#">svnRevisions</a>
K	17	ID for RMGView	ERZ 2000-NG_V1.8.0..	<a href="#">rmgvId</a>
J	18	FC-BIOS bootloader	1.05	<a href="#">versionBTL</a>
J	19	kernel	PicoMOD6 V1.11	<a href="#">versWinKern</a>
J	20	kernel Built	Jun 18 2012	<a href="#">dateWinKern</a>
J	21	kernel CRC	81455247	hex <a href="#">chksWinKern</a>
E *	22	approval kernel	81455247	hex <a href="#">inputWinKern</a>
J	23	kernel bootloader	1.10	<a href="#">versWinBL</a>
J	24	version FPGA	3.000	<a href="#">versionFPGA</a>
J	25	date FPGA	21-10-14	<a href="#">lchgFPGA</a>
J	26	checksum FPGA	6FC2	hex <a href="#">chksFPGA</a>

Enter Cancel Load defaults Refresh

**Figure 10: Menu EJ Software identification**

There is an additional microcontroller on the base circuit board for control of the FPGA and basic measuring functions whose program is monitored with a check number.

### Note

**This check number is a component of the custody transfer approval.**

The check number must be entered in coordinate **EJ10 Enable**. It is found in the menu **Documentation**, sub-menu **Identification** as "Activation key".

If a data book is generated via browser operation in the user visibility level, the ERZ2000-NG generates a check number with the parameters in the coordinate **EJ11**. The kernel also has a **Target check**, which can be found in the approval documenta-

tion and must be entered. This appropriate actual check number is calculated by the ERZ2000-NG with the WinCE operating system and displayed in **EJ21**. These check numbers are compared with each other continuously. If there is a deviation, the ERZ2000-NG issues an alarm with the message "A57-7 WinCE kernel CRC false".

**EK Identification of hardware**

Access	Line	Designation	Value	Unit
S	1	Manufacturer	RMG Messtechnik	
S	2	Year of construct.	2013	
S	3	Factory number	1234567890123456789	
S	4	Hardware ID	10	
S	5	Comment	keine	
B	6	Control panel	WIN2000_Front-3	
B	7	back panel	FC2000NG_RW-0	
B	8	controller	ERZ2000NG-0	
B	9	PC base	PicoGC-3	
B	10	interfaces	ERZ2004_C34-6	
B	11	Hart interfaces	ERZ2004_Hart-4	
B	12	digital interfaces	F58_Modul-3	
B	13	Ex inputs	Ex1-Modul-2	
D	14	OBIS Id.	7061 1301 2345 6789	

Enter Cancel Load defaults Refresh

**Figure 11: Menu EK Identification hardware**

Manufacturer-independent identification numbers for measuring devices (Object Identification System) are provided in coordinate **EK14 OBIS-ID**. The OBIS-ID consists of 4 groups of 4 numbers each. The groups are separated by a blank space for easier legibility.

**S**HHH **BB**FF FFFF FFFF

**S**:

Column (7 = gas)

**HHH**:

Manufacturer (061 = RMG)

**BB**:

Year of manufacture (2-digit, e.g. 13=2013)

**FF FFFF FFFF**:

Serial number (10-digit, only numbers)

The OBIS-ID cannot be edited directly and is generated automatically from the existing coordinates **EK02 Year of manufacture** and **EK03 Serial number**. Since the serial number in the ERZ2000-NG is a 20-character-long text field that is already used, there is generally a combination of numbers and letters in the field. The number may also be structured, e.g. "RMG-123/456/789". The software ignores all non-numerical characters when generating the number and the numbers are left in order. If the remainder number has less than 10 digits, leading zeros are shown. If the number has more than 10 digits, the highest-order are truncated.

## 2 Introduction

### 2.1 Operation

#### 2.1.1 Front panel

28

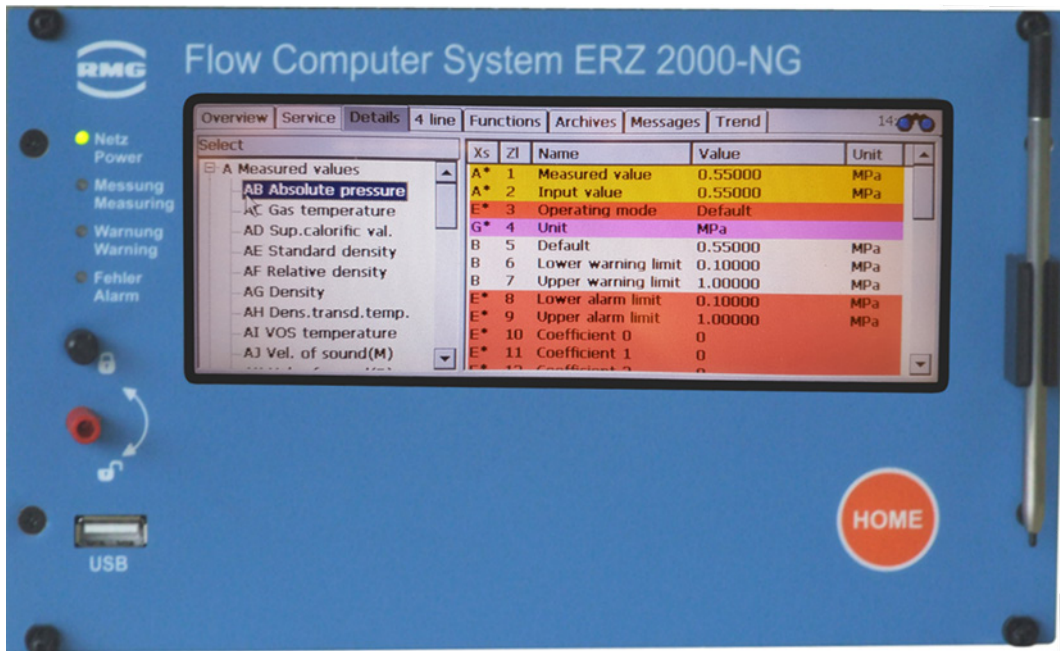


Figure 12: Front panel

The following display and operating elements are located on the front panel:

<b>Green LED (network)</b>		<b>Continuously illuminated:</b> Voltage indicator. <b>Blinking light:</b> User or calibration lock opened
<b>Orange LED (measurement)</b>		<b>Continuously illuminated:</b> Meter is connected and delivers data. <b>Blinking light:</b> Flow rate outside of permissible limits. <b>Off:</b> No flow.
<b>Yellow LED (warning)</b>		<b>Blinking light:</b> There is currently a fault in non-custody-transfer functions (warning) <b>Continuously illuminated:</b> A warning has been issued
<b>Red LED (fault)</b>		<b>Blinking light:</b> There is currently a fault in custody-transfer functions (alarm) <b>Continuously illuminated:</b> An alarm was issued since the last acknowledgment, but is no longer pending

**Custody transfer switch**



**Sealable rotary switch:** the custody transfer lock is opened at the mechanical limit stop.

**USB interface**

For connection of USB components (e.g. a mouse), sealed in custody transfer mode.

29

**Home button**

To jump to the startup/message screen (alternating)

**Touch screen**

Display and control panel.

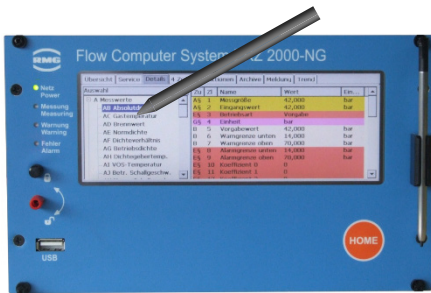
### 2.1.2 Operation on the touch screen

The touch screen enables operation via a graphic and largely self-explanatory user interface. You jump back to the start screen from any place in the menu with the "home" button. Pressing the button again jumps to the **"Message"** screen/menu.

<p><b>⚠ Caution</b></p>
<p><b>Operate the touch screen directly with your finger or use the supplied plastic stylus.</b></p> <p><b>Never use hard or sharp objects such as screwdrivers or pens (otherwise, there is a risk that the foil of the touch screen is scratched or torn).</b></p>

### 2.1.3 Remote control / parameterization

In addition to operation via the front panel, the touchscreen provides an additional convenient option to operate or parameterize the device either **locally or remotely** with a PC or notebook.

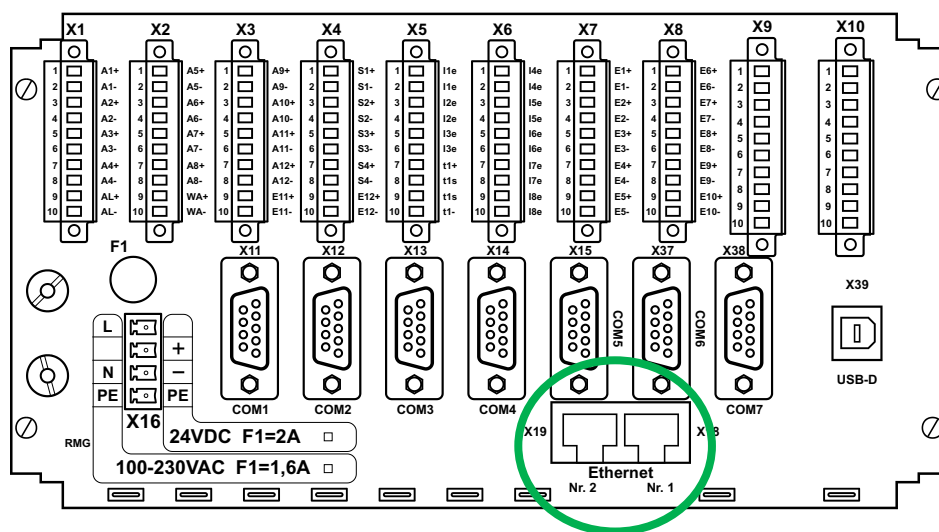


**Figure 13: Operation of the ERZ2000-NG**

Very simple adjustment takes place with the browser available on the PC (e.g. Internet Explorer, Firefox, etc.), which essentially corresponds to operation of the touchscreen. The ERZ2000-NG operates as a server and the PC operates as a client, wherein the local connection is established via a standard network cable (LAN cable).

The display on the touchscreen is identical to display on the browser; small differences are purely visual in nature and do not limit the adjustment options for the ERZ2000-NG via the web browser. After presentation of the various screens on the touch screen, the representation of the browser is usually shown below.

The LAN cable connects one of the 2 connection ports (Ethernet 1 or 2) on the rear side of the ERZ2000-NG (see *Figure 14: Rear side of the ERZ2000-NG and Ethernet interfaces*) with the local network of the PC.



**Figure 14: Rear side of the ERZ2000-NG and Ethernet interfaces**



**⚠ Caution**

Then the ERZ2000-NG can only be integrated into an existing network if the network permits integration of third-party devices.

Protected company networks may prohibit this access.

31

**Note**

As mentioned above, the ERZ2000-NG has 2 Ethernet interfaces. Two separate accesses to the ERZ2000-NG are also possible via these interfaces:

- consequently, 2 different users can view and/or download data (also different data) on the ERZ2000-NG, depending on their user rights.
- Parameterization applies to both users in equal measure.

In order to ensure that the network connections functions correctly, the correct network address in the TCP/IP network must be entered in the browser. This TCP/IP address can be read on the ERZ2000-NG. For this purpose, proceed as follows after starting up the device:

1. The ERZ2000-NG logs in after start-up with the following screen: *Figure 15: ERZ2000-NG start screen.*
2. The "**Overview**" tab is visible in the upper part of the display and can be selected with the stylus

Overview	Service	Details	4 line	Functions	Archives	Messages	Trend
DE1	5042.105	MWh	* Quantity of energy disturbance totalizer BM1 *				
DVb1	4689.961	*100 m3	* Disturbance totalizer for volume at base conditions BM1 *				
DVc1	7195.172	m3	* Disturbance totalizer for corrected volume at measurement cond				
DVm1	7195.172	m3	* Disturbance totalizer for volume at measurement conditions BM1				
DVo1	0.000	m3	* Original disturbance totalizer BM1 *				
SMe1	5314.566	*100 kg	* CO2 emission disturbance totalizer BM1 *				
SVx1	0.000	*100 m3	* Disturbance totalizer for volume at second base conditions BM1 *				
Vb2	1435.568	*100 m3	Totalizer for volume at base conditions BM2				
Vc2	1157.746	m3	Totalizer for corrected volume at measurement conditions BM2				

Figure 15: ERZ2000-NG start screen

3. The ERZ2000-NG logs in with the screen: Figure 16: Overview menu.

Overview	Service	Details	4 line	Functions	Archives	Flow	System
Analysis	Measured values	Orifice	Customer counters	Counters	Flow	System	
Name	Value	Unit	Description				
Vb(t)	0.000	*100 m3	Daily quantity today of volume at base conditions, integer part				
Vc(t)	0.000	m3	Daily quantity today of corrected volume at measurement condition				
Vm(t)	0.000	m3	Daily quantity today of uncorrected volume at measurement condit				
Vb(y)	0.000	*100 m3	Daily quantity yesterday of volume at base conditions, integer part				
Vc(y)	0.000	m3	Daily quantity yesterday of corrected volume at measurement conc				
Vm(y)	0.000	m3	Daily quantity yesterday of uncorrected volume at measurement cc				
VbU	0.554	*100 m3	Totalizer for volume at base conditions, undefined BM				

Figure 16: Overview menu

4. A second row with tabs appears, from which "System" can be selected.
5. After activation, the screen below appears: *Figure 17: Display of TCP/IP addresses.*

Overview   Service   Details   4 line   Functions   Archives   Messages   Trend			
Analysis   Measured values   Orifice   Customer counters   Counters   Flow   System			
Name	Value	Unit	Description
RAM	17334272	Bytes	free available memory
SVN	1219_179_220		SVN revisions
t	06-09-2018 17:27:57		Current date and time
TZ	W. Europe Standard T		Time zone and daylight-saving time rule
IP	10.20.13.71		own IP4-Address on Ethernet 1
IP	160.221.43.110		own IP4-Address on Ethernet 2
	Calibration lock		Current access

Figure 17: Display of TCP/IP addresses

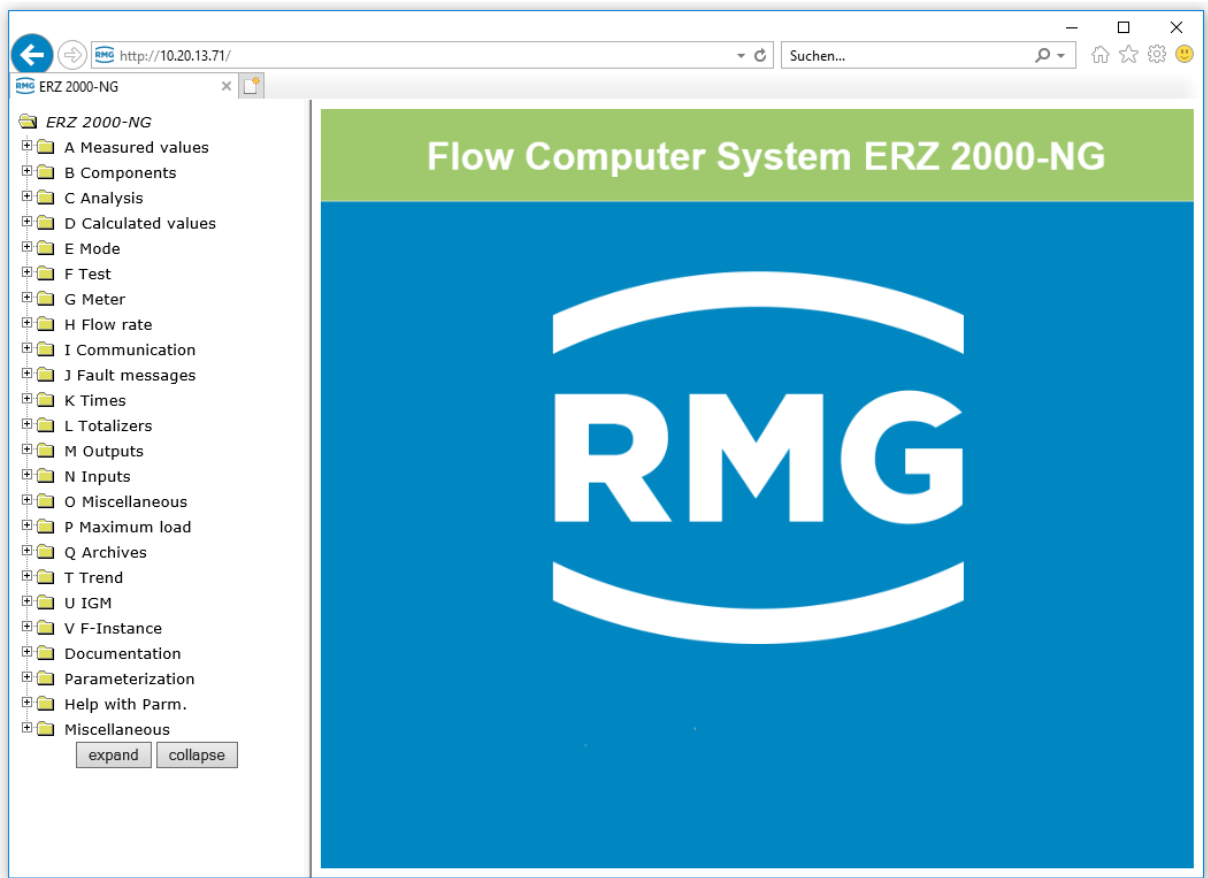
6. You can read the IP address of Interface 1 (ETH1) or 2 (ETH2).

When this TCP/IP address is entered as an address in the browser and the PC is connected in the same subnetwork as the ERZ2000-NG, the representation on the PC essentially corresponding to that of the display screen appears (*Figure 18: Display of the ERZ2000-NG in the browser*). Operation of the ERZ2000-NG is analogous to the activation on the display screen, using the mouse and clicking on the selected items. The selected parameters and settings you choose are adopted correctly, as though you had operated them directly on the touch screen.

**Note**

The ERZ2000-NG displays only the parameters that are relevant according to the intended use for the selected device type. Therefore, complete menus/columns and/or individual coordinates are hidden in the coordinate system – depending on the device type and operating mode setting.

Coordinates (functions) which are only intended for service purposes and testing are generally not displayed. Depending on the user profile and the selected device type, therefore, all parameters and data are generally not always visible.



**Figure 18: Display of the ERZ2000-NG in the browser**

## 2.2 Live browser and coordinate system

Links have a tree structure that is comparable to Windows Explorer. The relevant menu is opened by clicking on one of the : measurements, components, ... In the process, a symbol change from to or (bottom menu item) takes place and various sub-menus scan be selected by clicking on , such as Overview, Absolute pressure, Gas temperature, etc. A symbol change from to also takes place here. Then you see the content of the selected menu, see *Figure 19: Overview of measurements*.

Click on the first, top , then menu "A Measurements" appears in which measurements are listed in the menu tree. The first sub-item "AA Overview" ("click" on the top ) displays some of these values in the live browser (*Figure 19: Overview of measurements*).

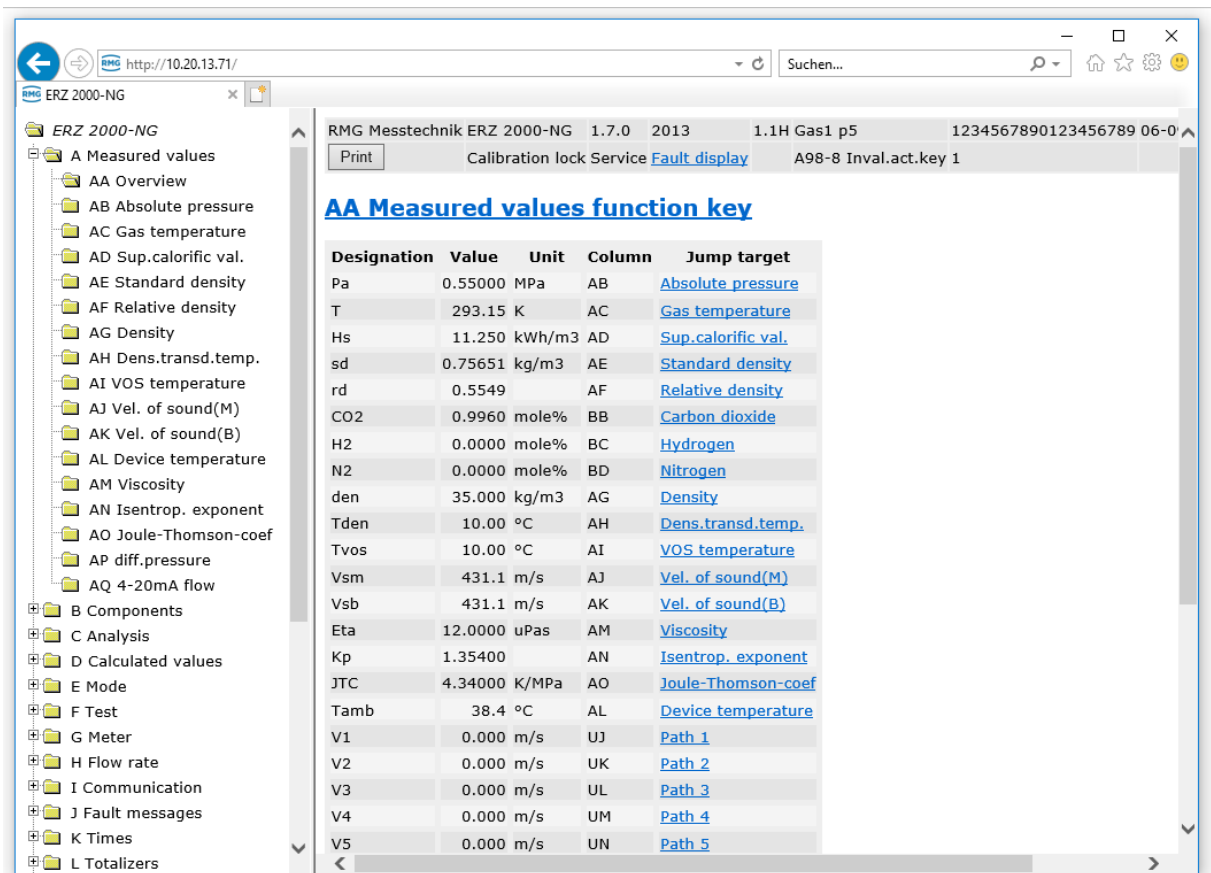
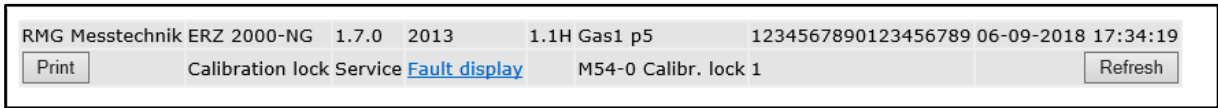


Figure 19: Overview of measurements

In the right-hand window, the following can be seen in the upper lines (*Figure 20: Top lines in the menu*):



**Figure 20: Top lines in the menu**

### Top line:

- |                    |  |
|--------------------|--|
| 1. RMG Messtechnik |  |
| 2. ERZ2000-NG      |  |
| 3. 1.7.0           | Consecutive number of the firmware version |
| 4. 2013            | Year of manufacture of the ERZ2000-NG      |
| 5. 1.1H            | Rail name EL 2                             |
| 6. Gas1 p5         | Measurement point EL 3                     |
| 7. 123456...       | Serial number EK 3                         |
| 8. 06-09-2018      | Current date                               |
| 9. 17:34:19        | Current time (17 means 5 pm)               |

### Note

#### For field 9: Time

**The time must change in the seconds!**

**A live connection is only provided thereafter.**

**All values, not only the values shown in *Figure 19: Overview of measurements* are updated "online" (continuously - live).**

**If the time does not change in seconds, there is no or only a poor connection between the ERZ2000-NG and the PC.**

**A poor connection can impede or completely block data transmission (e.g. the reading of archives).**

### Second line:

- |                              |   |
|------------------------------|---|
| 1. Print                     | The framed area shows an operable field; the displayed page is printed. |
| 2. Calibration lock / locked | Shows the status of the calibration lock.                               |
| 3. Service                   | Shows the access rights.  |

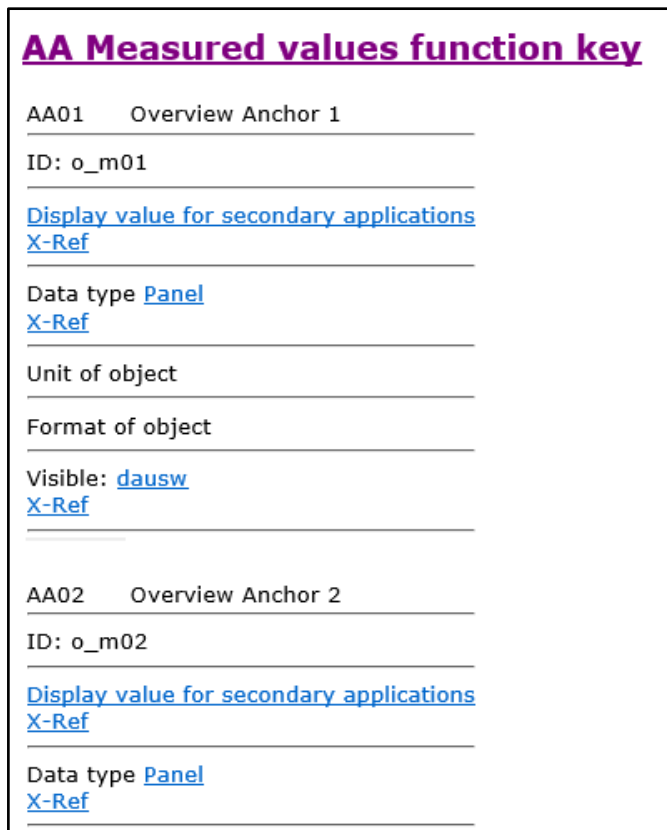
- |                          |   |
|--------------------------|---|
| 4. Fault display         | By double-clicking on this field, the currently pending faults are displayed. |
| 5. " "                   |   |
| 6. M54-0<br>Calibr. lock | The fault messages are displayed in consecutive order with fault number.      |
| 7. 1                     | Debug value (internal use)  |
| 8. " "                   |   |
| 9. Update                | The display is refreshed with the new applicable values                       |

37

The heading of the sub-menu is under these lines, e.g.

### AA Measurements function key

Various measurements are displayed here: p (absolute pressure), T (gas temperature), calorific value, etc. If you click on the **heading**, a menu appears providing explanations for the values displayed on the previous page (*Figure 21: Explanation menu*).



**Figure 21: Explanation menu**

Windows in which additional, in-depth information of the selected parameter is shown are opened by clicking on the underlined text.

Clicking on the Heading again will bring you back to the initial menu (*Figure 19: Overview of measurements*).

38

The corresponding live values, their unit (if available) are behind the measurements and the corresponding coordinates are in the menu and the jump target.

e.g.

Designation	Value	Unit	Column	Jump target
Pa	0.55000	MPa	AB	<a href="#">Absolute pressure</a>
T	293.15	K	AC	<a href="#">Gas temperature</a>
Hs	11.250	kWh/m <sup>3</sup>	AD	<a href="#">Sup.calorific val.</a>
sd	0.75651	kg/m <sup>3</sup>	AE	<a href="#">Standard density</a>
rd	0.5549		AF	<a href="#">Relative density</a>
CO <sub>2</sub>	0.9960	mole%	BB	<a href="#">Carbon dioxide</a>
H <sub>2</sub>	0.0000	mole%	BC	<a href="#">Hydrogen</a>
N <sub>2</sub>	0.0000	mole%	BD	<a href="#">Nitrogen</a>
den	35.000	kg/m <sup>3</sup>	AG	<a href="#">Density</a>

**Figure 22: Listing of measurements**

By clicking on the parameter under the jump target, the corresponding menu appears; e.g. clicking on the absolute pressure, the sub-menu "AB absolute pressure" (*Menu "AB Absolute pressure"*).



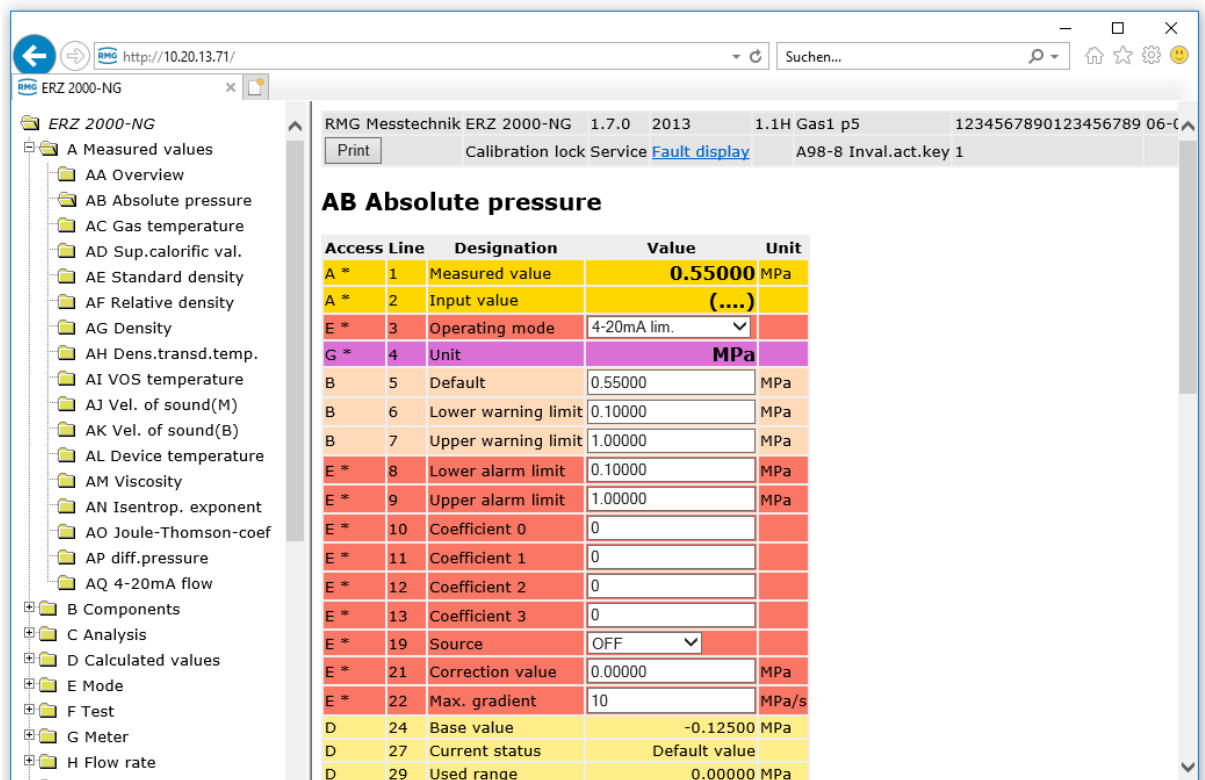


Figure 23: Menu "AB Absolute pressure"

The parameters on the right side belong to different categories, which is indicated with different colors, identification letters and other symbols in the left part on the right screen in the relevant line. The most important include:

- A Dark yellow Display values, change not possible
- B Beige User parameter, can be changed with user code
- E Red Custody transfer parameter, can be changed with open calibration switch
- G Violet Parameter for, e.g. units, can be changed in super user mode (1. Enter user code, 2. Open calibration switch)

This identification and the color assignment are shown in detail in *Chapter 2.2.1 Display*.

All measurements, calculation values, parameters and functions are arranged in a coordinate system. There are several tables with columns and lines in this coordinate system. Each table as a (umbrella) term, or a heading, under which all various points which have a logical connection with the term are summarized line by line; for example, points such as **AB04 Unit**, **AB06 (and AB07) Warning limit values**, etc. can be

found under **AB Absolute pressure**. These "points" are referred to as "coordinates" below. These individual coordinates are assigned additional meanings column-by-column:

40

Col-umn	1.	2.	3.	4.	5.	6.
	Access col-umn	Line num-ber				Identification
	Alpha-num. Identifica-tion	Numerical identifica-tion	Coordinate name	Value	Corre-sponding unit	Variable

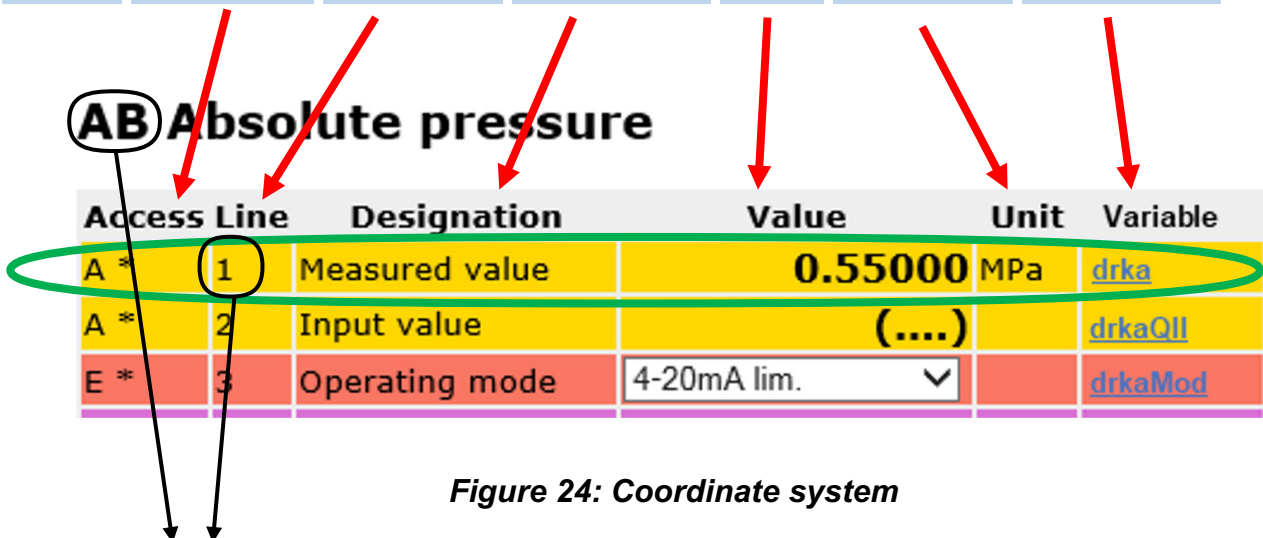


Figure 24: Coordinate system

With **AB01 Measurement variable**, the coordinate is uniquely identified in the green frame. The "Variable" column is only visible in Developer mode (see *Chapter 2.3 Access protection for data and settings*), for which the highest access level is required. The variable identification [drka](#) establishes a unique identification for the physical variable; this physical identification is assigned to the coordinate **AB01 Measurement variable**.

If applicable, a coordinate can also be a function, then these designations can also appear simultaneously.

The coordinates are arranged in a table, a coordinate system in the form of a matrix, in which each column (also identified with menu) is identified with two letters and each line is identified with a number. Furthermore, columns that belong together are summarized in groups and each group has the same first letters, e.g. "A" for the measurement columns. Each table as a (umbrella) term, or a heading, under which all various points which have a logical connection with the term are summarized line by line; for example, points such as "Unit", "Warning limit values", etc. are summarized under the term "Absolute pressure". Chapters belonging together are summarized under the first letters: AA, AB, AC, AD... / BA, BB, BC, ... / CA, CB, CC, CD.....

**Note**

The method of counting takes place with letter / number combinations beginning with

**AA = first column**

**01 = first line**

Chapters belonging together are summarized under the first letters: AA, AB, AC, AD... / BA, BB, BC, ... / CA, CB, CC, CD ...

Only the values that are relevant for the selected device type are displayed. Therefore, complete columns and/or individual coordinates are hidden in the coordinate system – depending on the device type and operating mode setting.

In addition, there are also coordinates (functions) that are only intended for service purposes and for review. Depending on the user profile and the selected device type, therefore, all parameters and data are not always visible.

The columns displayed to the left and the parameters and measurements displayed to the right depend on the selected user profile. All data is displayed in "Developer" mode only; the device is delivered in "User" mode.

### 2.2.1 Display

The visibility of coordinates and columns depends on the user profile setting. All coordinates are only visible in the developer setting. Example display:

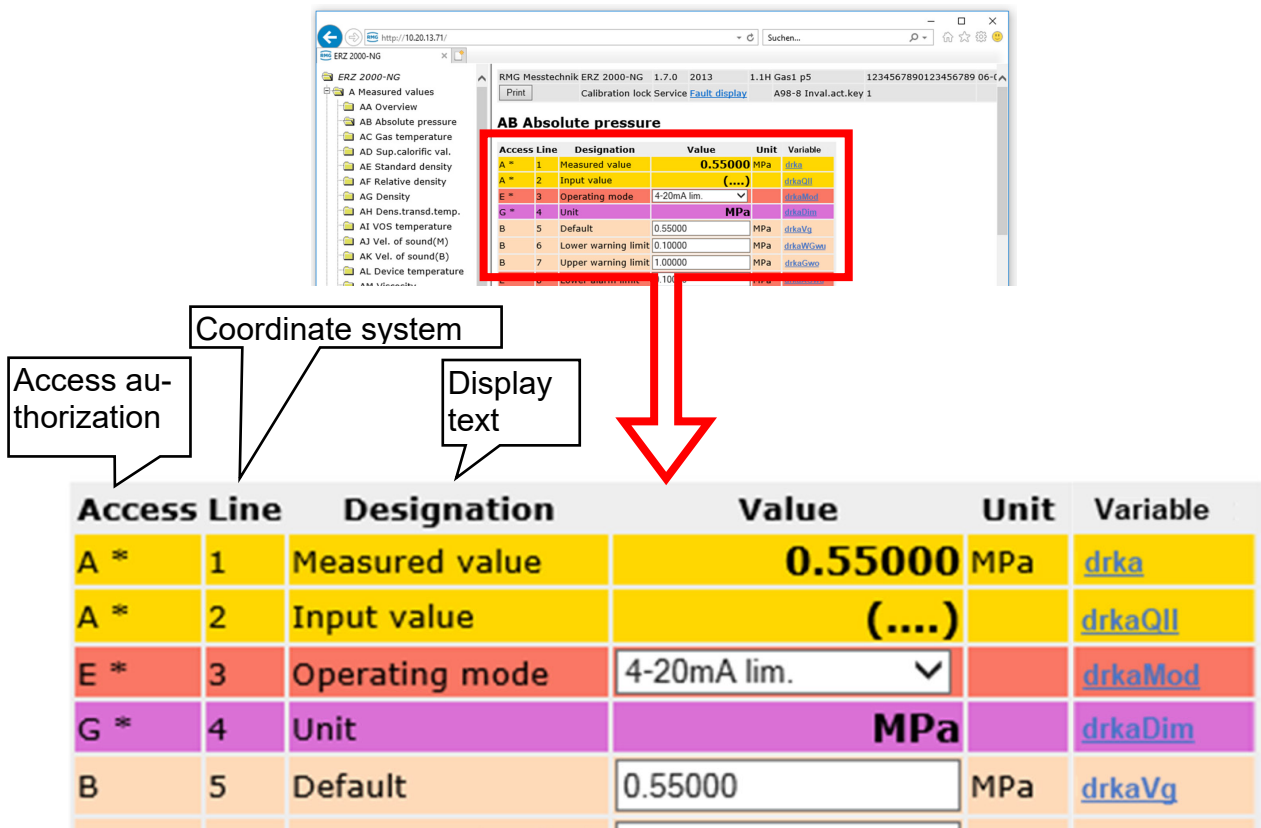


Figure 25: Parameter display

**Explanation of symbols in the Access column:**

- A** Display values, custody transfer, change not possible
- B** Parameter under single code word protection
- C** Special case: Code word entry/check
- D** General displays, display values, non-custody-transfer
- E** Parameters protected by official calibration
- F** Freeze value, not editable
- G** Parameter for, e.g. units and formats, can be changed in super user mode
- I** Interface variable – measurement, not editable
- J** Interface variable – imported type plate (e.g. hard), not editable

K	Constant, not editable
M	Imported measurement via Modbus, not editable
N	Non-custody-transfer totalizers, CO <sub>2</sub> , 2 <sup>nd</sup> volume at base cond., all disturbance totalizers, totalizers with an undefined billing mode, customer totalizers
P	Automatically changing input value with simple code word protection
Q	Automatically changing input value without protection
S	Parameter under super user protection
T	Parameter under double code word protection
W	Factory parameter can only be changed in the factory
X	Automatically changing input value under calibration switch
Y	Automatically changing input value under super user protection
Z	Custody transfer totalizers V <sub>m</sub> , V <sub>o</sub> , V <sub>c</sub> , E, M

The coordinate system runs horizontally from AA to QX (columns) and vertically from 1 to 99 (lines) (*Table 1: Coordinate system*)

AA	AB	AC	...	BA	BC	...	...	...	QW	QX
01										
02										
..										
..										
98										
99										

**Table 1: Coordinate system**

**Displayed parameters**

**Parameters**

These behave like constants. Editing changes, the value of the respective constant.

### Automatically changing values that can be edited

These values behave like changing values. Editing will change the initial value of these changing values, e.g. an offset. Example: Remaining time / trigger (KC06) for viewing the PTB telephone time service. KC06 contains the number of seconds until the next call of the telephone time service of the PTB. This call normally takes place once per day. The time can be shortened for testing and the call-up can be triggered prematurely.

### KC External time signal

Access Line	Designation	Value	Unit
T	1	Sync.mode input	OFF
T	2	timesync.tolerance	2 s
E *	3	Time sync. rule	Always
B	4	Retrigger success	90000 s
B	5	Retrigger fault	300 s
Q	6	PTB trigger	0 s

**Figure 26: Automatically changing value "KC06 remaining time / trigger"**

### Trigger

These values basically have no function in the basic state. A task is assigned and initiated with the editing. After completion of the task, the initiator returns to its basic state.

Click on the white field to change the value and then write the desired value.

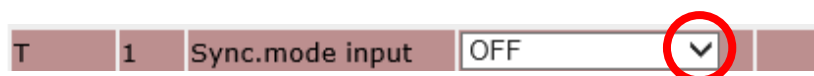
### Note

Please observe the unit behind this field and select suitable entries for this purpose.

### Parameter change:

There are different ways to change parameters:

- Fields with an arrow (e.g. under KC Time signal from external; T1 Sync mode input)



**Figure 27: "KC 01 Sync mode input"**

Clicking on the arrow (in the red circle) opens a selection menu (here).

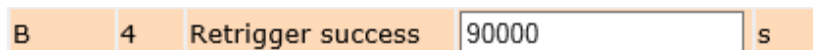
- Off
- DSfG
- Full minute
- In second 30
- ...

The desired parameter can be selected from these default parameters.

**Note**

This pre-selection influences the choice of additional parameters. For example, if you choose a constant for the compressibility coefficient calculation, no additional parameters, such as calorific value, gas proportions, etc. can be queried – depending on access authorization (*chapter 2.3 Access protection for data and settings*). With very high access authorization (e.g. super user), these values are still displayed, and changes can be made; however, these changes have no effects.

Other fields can also be described directly, such as:



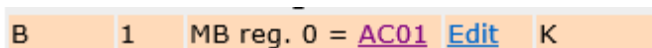
**Figure 28: Entry in fields (numbers)**

The desired time after which a re-login takes place is entered directly in the field (with the example 90000 s ≈ 1 day), the assigned unit ( [s] ) was already assigned. Other fields contain additional information that can also be entered directly (in Figure 29: Entry in fields (text ) the manufacturer "Rosemount" is entered).



**Figure 29: Entry in fields (text )**

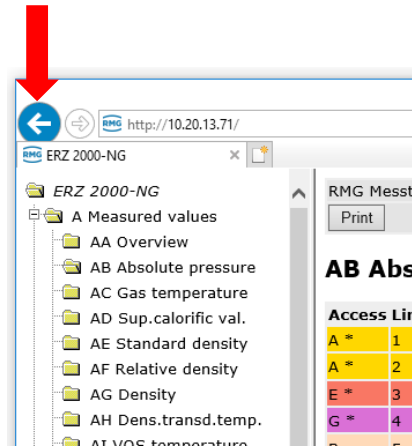
A final possibility is fields that can be activated (Figure 30: Activation of value fields).



**Figure 30: Activation of value fields**

By clicking on the value: "Edit", a sub-menu appears in which the variable **AC01 Temperature** can be changed.

With the back arrow of Explorer



**Figure 31: Back to the main menu**

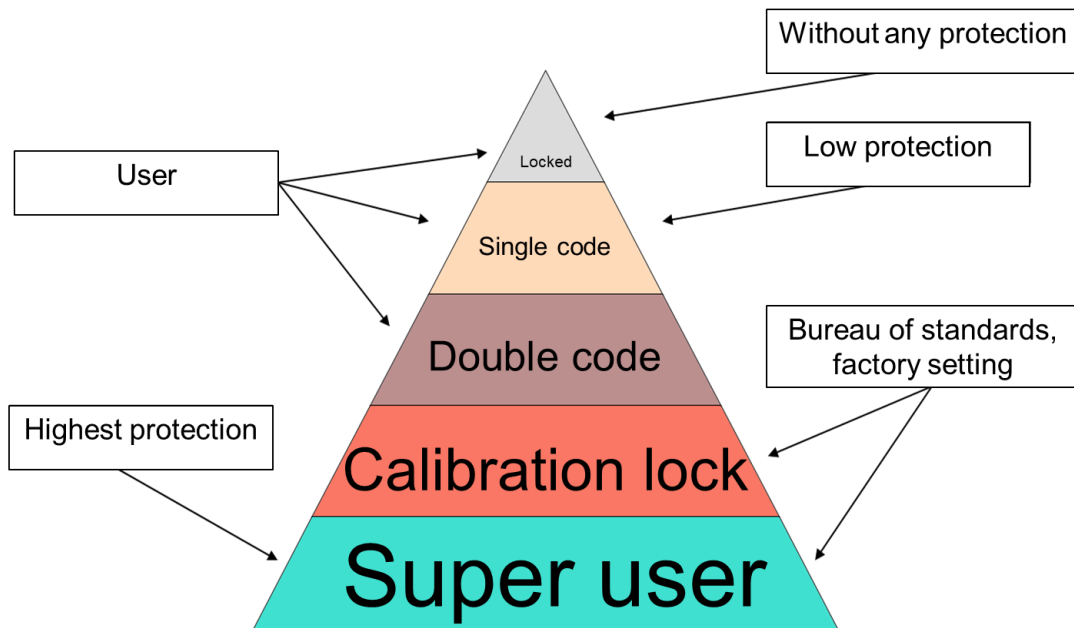
you return to the previous menu.

In order to familiarize yourself with the settings options and the type of setting, we recommend testing the settings options in the various "menus" in this display with the mouse. In order to avoid unnecessary "resetting", only save new settings if you actually need them.



### 2.3 Access protection for data and settings

The ERZ2000-NG permits the entry and adjustment of all editable values. A description is provided in *chapter 2.2.1 Display*. All editable values are access-protected, which prevents arbitrary changes. This access protection has different hierarchies that are illustrated in the following figure:



**Figure 32: Hierarchy of access protection**

The lowest protection level applies with a closed calibration switch and without entry of a protection code. With entry of the first protection code, you reach the next protection level and entry of the second protection enables access to the third protection level.

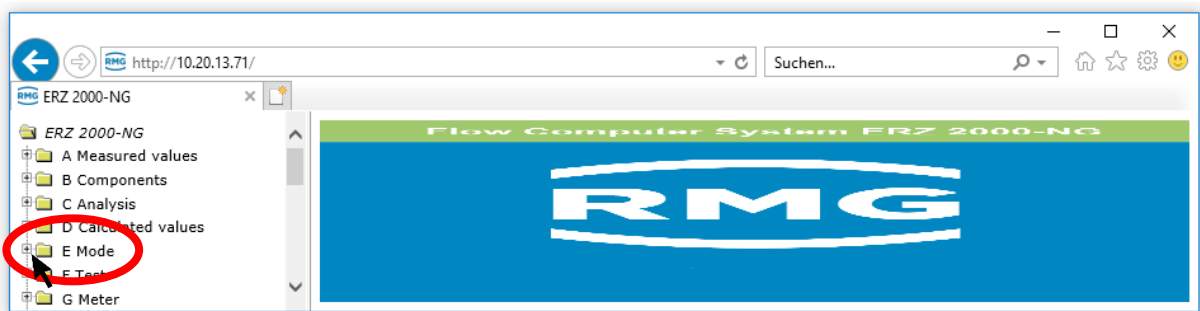
**These levels must be activated or deactivated by the user in order to make changes.**

The next protection level is subject to calibration protection and must only be opened by authorized persons. The factory settings are also made in this level. There is also a super user protection for the highest level. With higher protection level, all lower protection levels are open. The following *Table 2: Access rights* explains the access rights for the different protection levels.

<b>Closed</b>	Without influence on measurement and measurement accuracy, e.g. operating point testing resolution
<b>Single code</b>	Without influence on measurement and measurement accuracy, e.g. default values, warning limits, plausibility, comparisons, user protocols
<b>Double code</b>	Adaptation of gas property tables, has influence on measurement, but is then permitted and desired. Permission takes place with enabling of an operating mode protected by calibration lock.
<b>Calibration lock</b>	With influence on measurement and measurement accuracy. e.g. alarm limits, coefficients, operating modes (especially also operating modes allowing permission),
<b>Super user</b>	With considerable influence on measurement and measurement accuracy. e.g. calibration values, equipment, enabling of functions,

**Table 2: Access rights**

Access rights can be changed in the menu "**Details**". For this purpose, use the mouse activate the "+" in front of **E Mode**" *Figure 33: Changing access rights.*



**Figure 33: Changing access rights**

A sub-menu appears in which you activate "**ED Access**". Then the following appears

**ED Parameter access**

Access Line	Designation	Value	Unit	Variable
B 1	Revision mode	Rev. via contact ▾		<a href="#">revisMode</a>
C 2	Codeword 1	9999		<a href="#">code1</a>
C 3	Codeword 2	9999		<a href="#">code2</a>
A * 4	Current access	<b>Super user</b>		<a href="#">actAccess</a>
X 5	service mode	No ▾		<a href="#">serviceMod</a>
D 6	Current access	Super user		<a href="#">actAccess2</a>
D 8	Expired	1025	s	<a href="#">xsCur</a>
B 9	Max. opening time	1800	s	<a href="#">xsMax</a>
D 10	act. Op./Rev.	Operation		<a href="#">revisBtr</a>
D 11	Revision contact	OFF		<a href="#">ktkRevis</a>
B 12	Source revision ctc	OFF ▾		<a href="#">kzoRevis</a>
S 13	total. in revision	At rest ▾		<a href="#">zwRevMod</a>
S 14	Temp. at revision	retained value ▾		<a href="#">tRevMod</a>
S 15	Press. at revision	retained value ▾		<a href="#">pRevMod</a>

Enter   Cancel   Load defaults   Refresh

**Figure 34: Menu ED Access**

You can click on the fields after Code word 1 and Code word 2 and change the value of the code words with keyboard entry. If the rotating calibration lock is already open, the currently set code word can be read under the code words. The factory setting for both is "9999". This value must be entered (with calibration turned back and closed) and activated with "enter". The field **ED04 Current access** displays "Single code". If Code word 2 is activated with the same code = "9999" with the same procedure, then **ED04 Current access** displays "Double code". Separation between supplier and purchaser is possible with 2 different code words.

The calibration lock on the front panel is opened by turning it clockwise and **ED04 Current access** displays "Super user".

Without prior activation of Code words 1 and 2, **ED04 Current access** is "Calibration lock".

**Change of the code word**

In "Super user" access protection, the code word can also be changed. In the menu "Details", "E Mode", "ED Parameter access", the code words are read as encrypted numbers. If a new word is entered for the code word (series of numbers), it is activated with "enter" and "continue" for further activation of the access protection.

**Deactivation of the access protection**

In the first line of the touch screen, you can display the access protection level under the "Login" tab. The calibration lock on the front panel is closed by turning it counter-clockwise.

50

**Note**

**Normally, the calibration is now sealed by a calibration official.**

The function of the revision switch can be adjusted in the coordinate **ED01 Revision mode** and the revision bit in the bit string of the computer is set. It identifies archive entries and standard queries. When a revision is in progress, pulse outputs are switched off.

The "Super user" status and "Simple (Double) code" can be limited in coordinate **ED09** to a maximum of 14400 s (= 4 hours). In this connection, **ED08** shows the time remaining until the "Super user" or "Simple (double) code" access protection is closed automatically.

In order to finish the adjustment of the access authorization and the user profile, the user profile must be entered in the menu **EE Display** (see next chapter).

## 2.4 Basic settings

Before further settings can be changed, some basic settings must be entered in the menu EE Display. For better representation of the actual content, only the right part of the screen is shown (here and in the following).

### EE Display

Access	Line	Designation	Value	Unit	Variable
B	1	Language	English ▾		<a href="#">sprache</a>
B	2	User profile	Developer ▾		<a href="#">profil</a>
B	3	Screen saver	1092	min	<a href="#">schonZeit</a>
B	4	Information line	No ▾		<a href="#">infoLine</a>
B	5	Contrast Touchsrc.	2500		<a href="#">dspKontrast</a>
E *	6	Decimal delimiter	Point ▾		<a href="#">dezpkt</a>
E *	7	Cust.transf.ID mark	Asterisk ▾		<a href="#">epZeichen</a>
B	8	Buzzer mode	OFF ▾		<a href="#">buzzMod</a>
B	9	Message line	No ▾		<a href="#">errLine</a>
B	13	Coordinates	Yes ▾		<a href="#">kooAnz</a>
B	18	Qm/Vm-position	below-mentioned ▾		<a href="#">ovwVbPos</a>
B	19	Daily quantities	No ▾		<a href="#">showTMng</a>

Enter   Cancel   Load defaults   Refresh

Figure 35: Menu EE Display

First, select the user language in the coordinate **EE01 Language**; "German", "English" and "Russian" are available selections. The second coordinate **EE02 User profile** explains the user status:

- Gas meter reader
- User
- Service
- Developer
- Data input

Compare this with the enabling and access rights of the preceding *chapter 2.3 Access protection for data and settings*; with selection of the user profile, the access rights explained in this chapter must be available.

**Note**

Depending on the user profile, only the menus and coordinates with the settings options corresponding to the access rights are available. The other menus and coordinates are hidden.

52

**Recommendation: "Normal" customers select reader or user!**

The time after which the screen switches off following a period of inactivity is entered in the coordinate **EE03 Screen saver**. The coordinate **EE04 Information line** controls whether more detailed information (DSfG, Modbus, access, etc.) for the current coordinate is displayed in the fourth line of the display. The resolution can be adjusted between 1000 and 4000 in coordinate **EE05 Contrast Touchscr.**; 2500 is the presetting. A "comma" or "period" configured as a **Decimal separator** in **EE06**. "§ paragraph", "\* star", "# cross" or "none" can be selected as **EE07 Cust.transf.ID mark**. Custody transfer values in the display are identified by this additional symbol.

**Note****Important:**

At measuring points which are not operated for custody transfer, using the symbols above before these values is not permitted; no character ("none") is prescribed.

The coordinate **EE09 Message line** controls whether a pending fault message is displayed in the fourth line of the display. In **EE13 Coordinates**, "yes" initiates permanent display of the coordinate in the second line of the display; "no" initiates the display of the coordinate strictly when navigating in the fourth line of the display.

### EL Description site

Access Line	Designation	Value	Unit	Variable
B	1	Measuring priority	Main measurement	<a href="#">messtyp</a>
B	2	Line name	1.1H	<a href="#">schiene</a>
B	3	Measuring point	Gas1 p5	<a href="#">messort</a>
B	4	Postal address	Baker street	<a href="#">postadr</a>
B	7	Design. meas.pt.	Design.meas. point	<a href="#">zpktbez</a>
B	8	Owner	Owner	<a href="#">owner</a>
B	11	Start-up	01-01-1970 01:00:00	<a href="#">inbetrieb</a>
B	12	Responsible person	Person in charge	<a href="#">officer</a>
B	13	Phone No.	Phone number	<a href="#">telno</a>
B	14	Inspector	Calibration official	<a href="#">eichbeamter</a>
E *	15	Last calibration	01-01-1970 01:00:00	<a href="#">IEich</a>
B	16	Line number	1	<a href="#">strecke</a>
B	17	Billing	Billing measurement	<a href="#">abrTypB</a>

Figure 36: EL Description site

The menu **EL Description site** is provided essentially for storage of information about your measurement. Please fill out these fields completely by writing directly in them. Choose between main measurement and comparison measurement in the coordinate **EL01 Measuring priority**. Coordinate **EL17 Billing** gives you the choice between "standby measurement" and normal "Billing measurement".

### ES Parameter changes

Access Line	Designation	Value	Unit	Variable
D	1	Parameter	Language	<a href="#">cparTxId</a>
D	2	Value = <b>EE01</b>	English	<a href="#">cparIdx</a>
D	3	via access	Browser	<a href="#">cparQll</a>
D	4	Time stamp	13-09-2018 16:02:58	<a href="#">cparTim</a>
D	5	Flag bit pattern	1	<a href="#">cparFlag</a>

Figure 37: Menu ES parameter changes

In menu **ES Parameter changes**, the last changes are documented. This is done so that changes can be reviewed and reversed, if necessary.

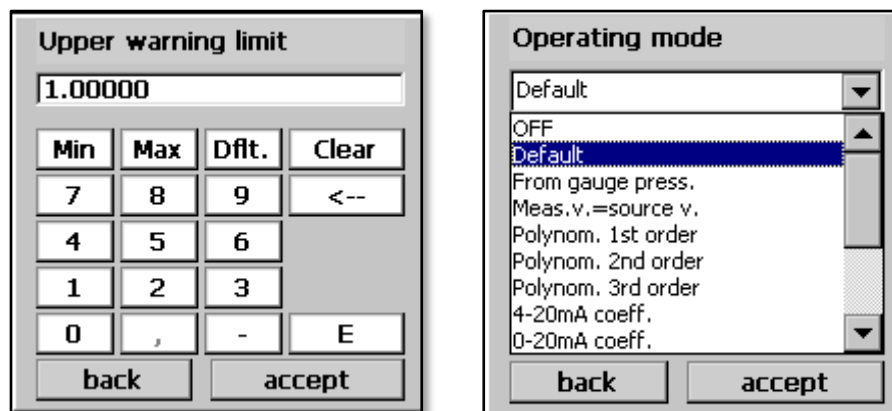
## 2.5 Start screen

The representations of the touch screen of the ERZ2000-NG are shown below. For this purpose, supplementary explanations of the figures on the browser are provided.

There are two essential with the internet browser differences in comparison with the representation:

- The archives (visible in the browser as the Q column) are located in the "Archives" tab (see below).
- Only the matrix is shown; there are some additional data and functions available with the browser

To change parameters, you go to the corresponding line on the right side and an input field appears:



**Figure 38: Input field**

The left field is provided for entry of the numerical values; the right field is provided to select a mode. The new numerical value and/or the new mode is adopted with "accept".

After the power is connected to the ERZ2000-NG, the start screen appears, which is visible in *Figure 39: Start screen*.



Name	Value	Unit	Description
E(t)	43131.016	MWh	Daily quantity today of energy, integer part
M(t)	34548.124	*100 kg	Daily quantity today of mass, integer part
Vb(t)	43131.016	*100 m3	Daily quantity today of volume at base conditions, integer part
Vc(t)	75257.036	m3	Daily quantity today of corrected volume at measurement condition
Vm(t)	75257.036	m3	Daily quantity today of uncorrected volume at measurement condition
E(y)	3231.271	MWh	Daily quantity yesterday of energy, integer part
M(y)	2520.735	*100 kg	Daily quantity yesterday of mass, integer part

**Figure 39: Start screen**

The start screen appears after a restart of the device or after pressing the "HOME" key. The start screen shows all activated counters. If a counter is activated in the ERZ2000-NG, but no values are running, this counter is also displayed at the top with a volume flow  $Q = 0$ . The other counters become visible with vertical scrolling (right).

The individual screens are arranged like tabs. They represent the top level of the operating menu and are accessible via the buttons on the upper bar. The following screens, i.e. "menus" are available, where the following sections are displayed.

<b>Overview</b>	Start screen with counters (and important measurement values)
<b>Service</b>	Service functions
<b>Details</b>	List of all measurements and parameters of the ERZ2000-NG
<b>4 line</b>	Control buttons and 4-line display like the ERZ2000
<b>Functions</b>	Displays and functions for test and calibration
<b>Archives</b>	Archive entries
<b>Messages</b>	Color event and fault messages (alarms, warnings and notices)
<b>Trend</b>	Graphic representation of the measurement curve over time (variable parameters)

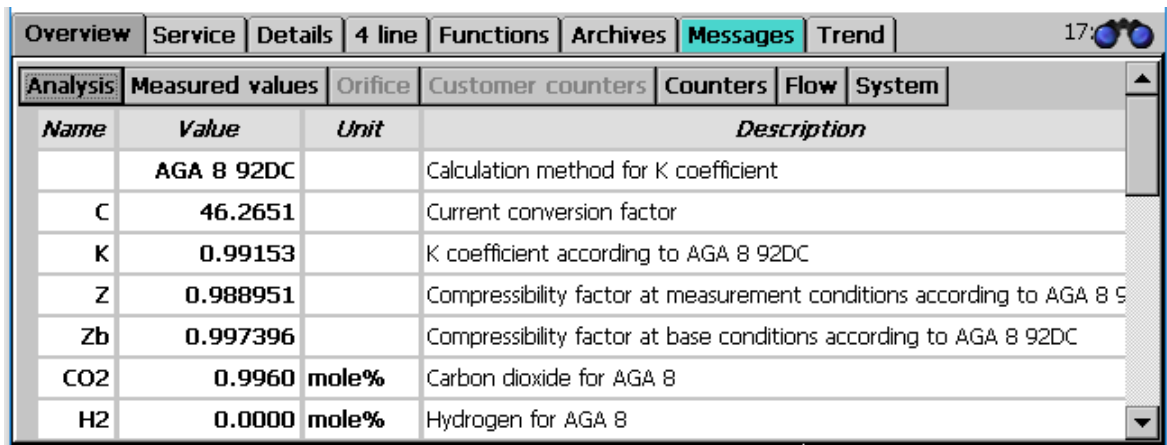
If you scroll to the top right, the daily values are shown in the upper part of the table (tab).

## 2.5.1 Overview

If you scroll to the top in the overview or tap on the "Overview" menu item again; six selection fields appearing in the upper line can be used to switch to other tables, i.e. sub-menus.

56

### 2.5.1.1 Analysis



Name	Value	Unit	Description
	AGA 8 92DC		Calculation method for K coefficient
C	46.2651		Current conversion factor
K	0.99153		K coefficient according to AGA 8 92DC
Z	0.988951		Compressibility factor at measurement conditions according to AGA 8 92DC
Zb	0.997396		Compressibility factor at base conditions according to AGA 8 92DC
CO2	0.9960	mole%	Carbon dioxide for AGA 8
H2	0.0000	mole%	Hydrogen for AGA 8

**Figure 40: Overview Analysis sub-menu**

The calculation method and gas data are displayed here. The calculation method – AGA 8 92DC in this case – is listed in the first field under value.

#### Note

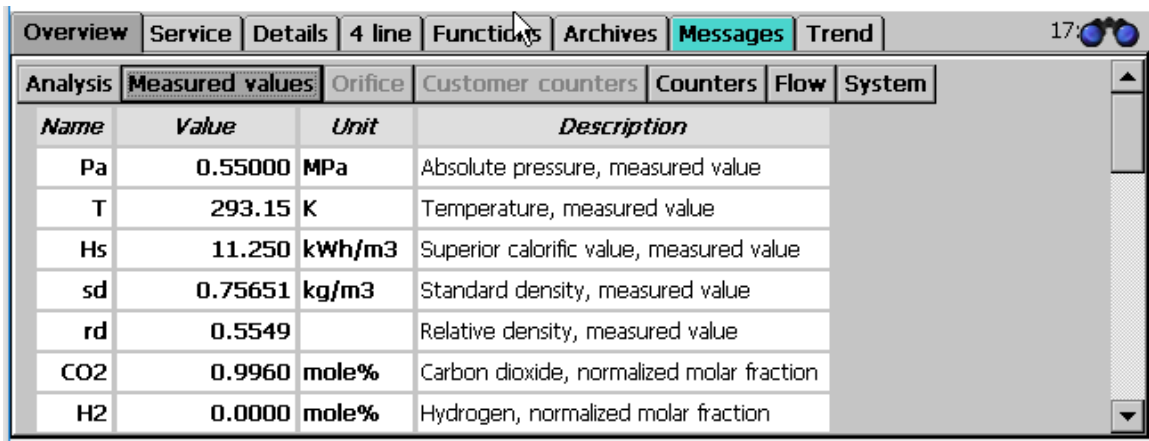
The calculation method can only be changed in non-custody transfer mode.

In addition to further gas-specific parameters, the data for the gas composition, which varies depending on the selected calculation process, is provided here.

Double-clicking opens the "Details" menu (*chapter 2.5.3 Details*) and the coordinate **CC05 Calculation type** can be activated. There is a selection menu available there in which other calculation methods can be selected.

For further information about gas analysis, refer to chapter 6 *Parameter* of the gas.

2.5.1.2 Measurements

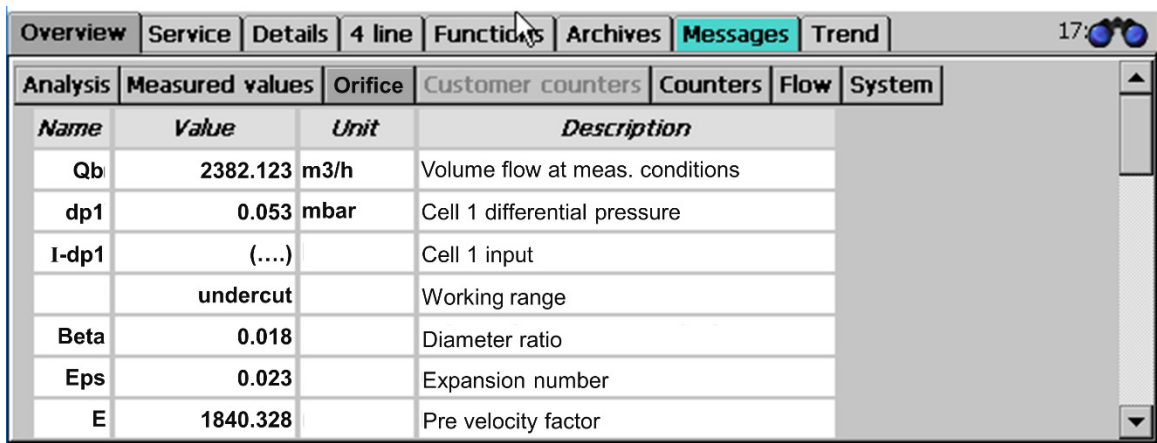


Overview   Service   Details   4 line   Functions   Archives   Messages   Trend							
Analysis   Measured values   Orifice   Customer counters   Counters   Flow   System							
Name	Value	Unit	Description				
Pa	0.55000	MPa	Absolute pressure, measured value				
T	293.15	K	Temperature, measured value				
Hs	11.250	kWh/m3	Superior calorific value, measured value				
sd	0.75651	kg/m3	Standard density, measured value				
rd	0.5549		Relative density, measured value				
CO2	0.9960	mole%	Carbon dioxide, normalized molar fraction				
H2	0.0000	mole%	Hydrogen, normalized molar fraction				

Figure 41: Overview Measurements sub-menu

Measurements and resulting calculated values, such as pressure and temperature, as well as values such as density, calorific value, velocity of sound and viscosity are shown in this display.

2.5.1.3 Orifice plate



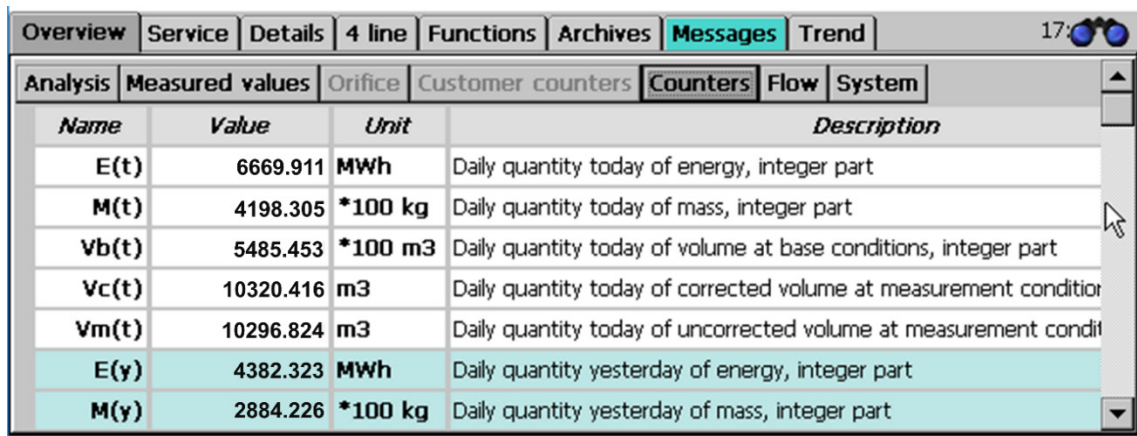
Overview   Service   Details   4 line   Functions   Archives   Messages   Trend							
Analysis   Measured values   Orifice   Customer counters   Counters   Flow   System							
Name	Value	Unit	Description				
Qb	2382.123	m3/h	Volume flow at meas. conditions				
dp1	0.053	mbar	Cell 1 differential pressure				
I-dp1	(...)		Cell 1 input				
	undercut		Working range				
Beta	0.018		Diameter ratio				
Eps	0.023		Expansion number				
E	1840.328		Pre velocity factor				

Figure 42: Overview Orifice plate sub-menu

Various data of the orifice plate is displayed in this sub-menu, such as the volume flow at measurement conditions, the pressure drop  $\Delta p$  through the orifice plate, diameter ratio of the orifice plate to the pipe cross-section and gas parameters.

For further information about flow measurement with the orifice plate, refer to *chapter 5.5 Orifice plate diameter*.

## 2.5.1.4 Counters

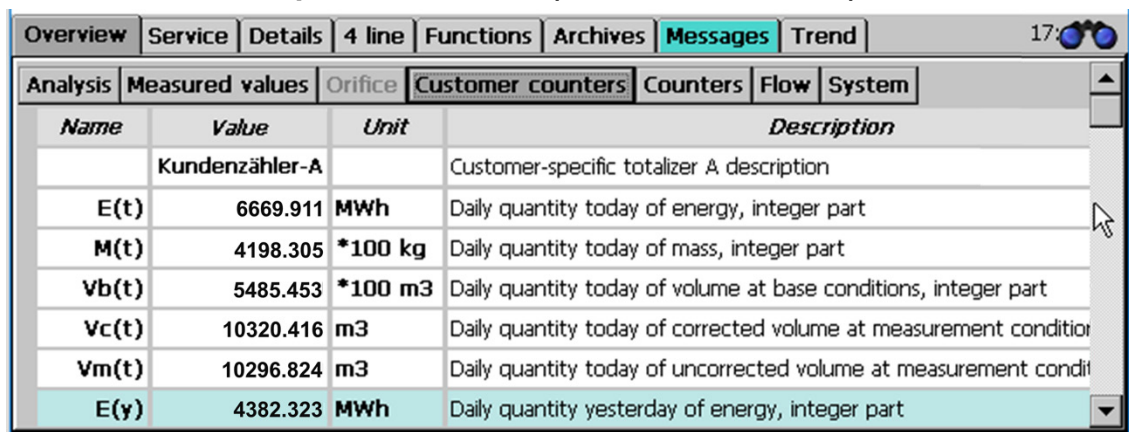


Name	Value	Unit	Description
E(t)	6669.911	MWh	Daily quantity today of energy, integer part
M(t)	4198.305	*100 kg	Daily quantity today of mass, integer part
Vb(t)	5485.453	*100 m3	Daily quantity today of volume at base conditions, integer part
Vc(t)	10320.416	m3	Daily quantity today of corrected volume at measurement condition
Vm(t)	10296.824	m3	Daily quantity today of uncorrected volume at measurement condition
E(y)	4382.323	MWh	Daily quantity yesterday of energy, integer part
M(y)	2884.226	*100 kg	Daily quantity yesterday of mass, integer part

Figure 43: Overview Counters sub-menu

This menu shows the various counters, a color underline assigns different times or other classifications to the counters. All 4 billing modes can also be activated as CO<sub>2</sub> counters for energy-efficient monitoring.

## 2.5.1.5 Customer-specific counters (customer counters)



Name	Value	Unit	Description
	Kundenzähler-A		Customer-specific totalizer A description
E(t)	6669.911	MWh	Daily quantity today of energy, integer part
M(t)	4198.305	*100 kg	Daily quantity today of mass, integer part
Vb(t)	5485.453	*100 m3	Daily quantity today of volume at base conditions, integer part
Vc(t)	10320.416	m3	Daily quantity today of corrected volume at measurement condition
Vm(t)	10296.824	m3	Daily quantity today of uncorrected volume at measurement condition
E(y)	4382.323	MWh	Daily quantity yesterday of energy, integer part

Figure 44: Overview Customer counters sub-menu

Along with the counters that are dependent on the billing mode, there are two additional customer-specific counters sets that can be activated.

For further information about the counters, refer to Menu L Totalizers. In menu **LA Overview**, the values of the different counters are displayed in an overview.

LA Totalizers function key

Designation	Value	Unit	Column	Jump target
E(t)	0.000	MWh	LT	<a href="#">Daily quantities</a>
M(t)	0.000	*100 kg		
Vb(t)	0.000	*100 m3		
Vc(t)	0.000	m3		
Vm(t)	0.000	m3		
E(y)	0.000	MWh		
M(y)	0.000	*100 kg		
Vb(y)	0.000	*100 m3		
Vc(y)	0.000	m3		
Vm(y)	0.000	m3		
EU	0.640	MWh	LJ	<a href="#">Tot. undef.BM</a>
MU	0.965	*100 kg		
VbU	0.554	*100 m3		
VcU	2.758	m3		
VmU	2.758	m3		
VoU	0	m3		
MeU	1.232	*100 kg		
VxU	0.000	*100 m3		
E1	81792.597	MWh	LB	<a href="#">Totalizer BM1</a>
M1	63240.262	*100 kg		
Vb1	76810.240	*100 m3		
Vc1	111118.049	m3		
Vm1	111118.049	m3		
Vo1	0.000	m3		
Me1	64852.070	*100 kg		
Vx1	0.000	*100 m3		
DE1	5042.105	MWh	LC	<a href="#">Dist.tot. BM1</a>
DM1	3896.602	*100 kg		
DVb1	4689.961	*100 m3		
DVc1	7195.172	m3		
DVm1	7195.172	m3		
DVo1	0.000	m3		
SMe1	5314.566	*100 kg		
SVx1	0.000	*100 m3		
E2	1658.081	MWh	LD	<a href="#">Totalizer BM2</a>
M2	1220.233	*100 kg		
Vb2	1435.568	*100 m3		
Vc2	1157.746	m3		
Vm2	1157.746	m3		
Vo2	0.000	m3		
Me2	2542.318	*100 kg		

Vx2	0.000	*100 m3		
DE2	249.061	MWh	LE	<a href="#">Dist.tot. BM2</a>
DM2	183.291	*100 kg		
DVb2	215.637	*100 m3		
DVc2	173.905	m3		
DVm2	173.905	m3		
DVo2	0.000	m3		
SMe2	381.882	*100 kg		
SVx2	0.000	*100 m3		
E3	0.000	MWh	LF	<a href="#">Totalizer BM3</a>
M3	0.000	*100 kg		
Vb3	0.000	*100 m3		
Vc3	0.000	m3		
Vm3	0.000	m3		
Vo3	0.000	m3		
Me3	0.000	*100 kg		
Vx3	0.000	*100 m3		
DE3	0.000	MWh	LG	<a href="#">Dist.tot. BM3</a>
DM3	0.000	*100 kg		
DVb3	0.000	*100 m3		
DVc3	0.000	m3		
DVm3	0.000	m3		
DVo3	0.000	m3		
SMe3	0.000	*100 kg		
SVx3	0.000	*100 m3		
E4	0.000	MWh	LH	<a href="#">Totalizer BM4</a>
M4	0.000	*100 kg		
Vb4	0.000	*100 m3		
Vc4	0.000	m3		
Vm4	0.000	m3		
Vo4	0.000	m3		
Me4	0.000	*100 kg		
Vx4	0.000	*100 m3		
DE4	0.000	MWh	LI	<a href="#">Dist.tot. BM4</a>
DM4	0.000	*100 kg		
DVb4	0.000	*100 m3		
DVc4	0.000	m3		
DVm4	0.000	m3		
DVo4	0.000	m3		
SMe4	0.000	*100 kg		
SVx4	0.000	*100 m3		

Refresh

Figure 45: Menu: LA Overview

### LB Totalizer, billing mode 1

Access Line	Designation	Value	Unit	Variable
Z *	1	Vol. at base cond.	76810	*100 m3 <a href="#">Vn1</a>
Z *	2	Vol.base fraction	.239998	*100 m3 <a href="#">Vn1R</a>
Z *	3	Vol.at.base ovfl	0	<a href="#">OfVn1</a>
Z *	4	Energy	81792	MWh <a href="#">E1</a>
Z *	5	Energy fraction	.596735	MWh <a href="#">E1R</a>
Z *	6	Energy Overflow	0	<a href="#">OfE1</a>
Z *	7	Corr.vol.meas.	111118	m3 <a href="#">Vk1</a>
Z *	8	Corr.vol.meas.frac.	.048975	m3 <a href="#">Vk1R</a>
Z *	9	Corr.vol.meas.ovfl.	0	<a href="#">OfVk1</a>
Z *	10	Vol. at meas.cond.	111118	m3 <a href="#">Vu1</a>
Z *	11	Vol.meas.fraction	.048975	m3 <a href="#">Vu1R</a>
Z *	12	Vol.at.meas ovfl	0	<a href="#">OfVu1</a>
Z *	13	Mass	63240	*100 kg <a href="#">M1</a>
Z *	14	Mass fraction	.262214	*100 kg <a href="#">M1R</a>
Z *	15	Mass Overflow	0	<a href="#">OfM1</a>
N	16	CO2 emission	64852	*100 kg <a href="#">CC1</a>
N	17	CO2 emission frac	.069796	*100 kg <a href="#">CC1R</a>
N	18	CO2 emission ovfl	0	<a href="#">OfCC1</a>
Z *	19	Original totalizer	0	m3 <a href="#">Vo1</a>
Z *	20	Orig.tot.fraction	.000000	m3 <a href="#">Vo1R</a>
D	21	DSfG status B	Okay	<a href="#">zvk1Estt</a>
D	22	DSfG status M	Okay	<a href="#">zvk1Estt</a>
N	25	Vol.2nd.base.cond.	0	*100 m3 <a href="#">Vx1</a>
N	26	Vol.2nd.base.frac	.000000	*100 m3 <a href="#">Vx1R</a>
N	27	Vol.2nd.base.ovfl	0	<a href="#">OfVx1</a>
F	61	Vol. at base cond.	76810	*100 m3 <a href="#">fVn1</a>
F	62	Vol.base fraction	.239998	*100 m3 <a href="#">fVn1R</a>
F	63	Vol.base overflow	0	<a href="#">fOfVn1</a>
F	64	Energy	81792	MWh <a href="#">fE1</a>
F	65	Energy fraction	.596735	MWh <a href="#">fE1R</a>
F	66	Energy overflow	0	<a href="#">fOfE1</a>
F	67	Corr.vol.meas.	111118	m3 <a href="#">fVk1</a>
F	68	Corr.vol.meas.frac.	.048975	m3 <a href="#">fVk1R</a>
F	69	Corr.vol.meas.ov.	0	<a href="#">fOfVk1</a>
F	70	Vol. at meas.cond.	111118	m3 <a href="#">fVu1</a>
F	71	Vol.meas.fraction	.048975	m3 <a href="#">fVu1R</a>
F	72	Vol.meas. overflow	0	<a href="#">fOfVu1</a>
F	73	Mass	63240	*100 kg <a href="#">fM1</a>
F	74	Mass fraction	.262214	*100 kg <a href="#">fM1R</a>
F	75	Mass overflow	0	<a href="#">fOfM1</a>
F	79	Original totalizer	0	m3 <a href="#">fVo1</a>
F	80	Orig.tot.fraction	.000000	m3 <a href="#">fVo1R</a>
F	85	Vol.2nd.base.cond.	0	*100 m3 <a href="#">fVx1</a>
F	86	Vol.2nd.base.frac	.000000	*100 m3 <a href="#">fVx1R</a>
F	87	Vol.2nd.base.ov.	0	<a href="#">fOfVx1</a>

Refresh

Figure 46: Menu: LB Totalizer BM1

The counters of the 4 billings modes are summarized in the sub-menus **LB Totalizer BM 1**, **LD Totalizer BM 2**, **LF Totalizer BM 3** and **LH Totalizer BM 4** in the menu **L Totalizers**; the disturbance counters are located in the sub-menus **LC Dist. tot. BM 1**, **LE Dist. tot. BM 2**, **LG Dist. tot. BM 3** und **LI Dist. tot. BM 4**. Since the structure of these menus is the same, only **LB Totalizer BM 1** is shown here in detail.

**Note**

Along with the counters that are dependent on the billing mode, there are two additional customer-specific counter sets that can be activated in menu **EB Base values**.

To activate the additional counter sets, the value 1 or 2 must be selected in coordinate **EB23 Customer counters** in menu **EB Base values**. For this purpose, the security level "User" (see chapter 2.3 *Access protection for data and settings*) must be activated with entry of the code word. The calibration switch can remain closed.

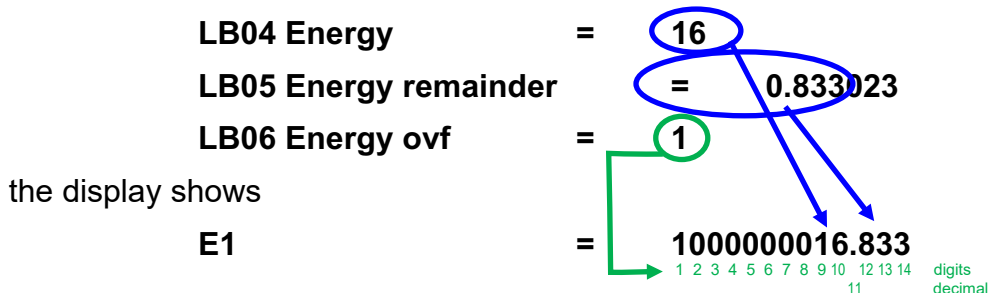
The configuration can be carried out in menu **L Totalizers**, sub-menu **LV Customer totaliz. A** and sub-menu **LW Customer totaliz. B**. A unique name and the totalizer behavior can be adjusted here. The totalizer status can be adjusted arbitrarily in sub-menu **LX Setting.custom.tot** with coordinate **LX 99 Counter setting** (Idle, All Tot=0, all overflows=0, custom, Vc=Vm, Vx=Vb)

The representation is explained based on the example of energy **LB04 Energy**, **LB05 Energy fraction** and **LB06 Energy Overflow** For this purpose, the representation type must be adjusted in coordinate **LK29 No of digits** (see below). There are 2 settings:

<b>Standard setting</b>	9 digits without fraction
<b>Counter of large quantities</b>	14 digits plus 3 decimal places

The 9 or 14 digit representation applies for all counters simultaneously.

If



The quantity of the carbon dioxide arising from the combustion of natural gas with air is in coordinates **LB16 – LB18**.

Menu **LJ Tot. undef. BM** also has a similar structure. Then this totalizer counts if the billing mode is invalid (e.g. in case of an incorrect switch position).

62

Menu **LK Counter parameters** enables some important parameter adjustments.

### **LK Counter parameter**

Access Line	Designation	Value	Unit	Variable
G *	3	Vol.meas. unit	<b>m3</b>	<a href="#">vuDim</a>
G *	6	Vol. base unit	<b>*100 m3</b>	<a href="#">vnDim</a>
G *	9	Energy unit	<b>MWh</b>	<a href="#">eDim</a>
G *	12	Mass unit	<b>*100 kg</b>	<a href="#">mDim</a>
D	13	Tot.formation	At rest	<a href="#">zwStop</a>
D	14	Cycle pulses	.000000	pulses <a href="#">actPuls</a>
D	15	Accumulated pulses	.000000	pulses <a href="#">pulsAccu</a>
E *	22	Totalizer mode	Runs	<a href="#">zwkMod</a>
B	23	Max. accumulation	100000	pulses <a href="#">accuMax</a>
B	26	Chan. stat. mode	new definition	<a href="#">kanStMod</a>
G *	29	No. of digits	<b>14</b>	<a href="#">zwkdigits</a>
G *	30	Totalizer format	<b>%lu</b>	<a href="#">zwkFrm</a>
E *	31	Vo Vol.meas. unit	m3	<a href="#">voDim</a>

Enter Cancel Load defaults Refresh

**Figure 47: Menu: LK Counter parameters**

The counter can be converted to a different unit in this menu. In order to convert the counters to different units, super user access is required, i.e. user code and calibration switch must be open. In menu **LK Counter parameters**, the standard setting of the volume at measurement conditions Vm and volume at base conditions Vb of energy and mass of the meters can be converted to different units in coordinates **LK03 Vol.meas. unit** to **LK12 Mass unit**. For this purpose, different values are available when clicking on [edit](#) (appears under value in access super user).

The standard setting for the display is 9 digits without remainder. Dedicated text and conversion functions are available for selection of the unit.

#### Note

For the totalizing of large quantities, the display of the counters can be changed from 9 digits to 14 digits plus 3 decimal places.

The 9 or 14 digit representation applies for all totalizers simultaneously.



The 9 or 14 digit representation type is selected in coordinate **LK29 No. of digits**.

**Note**

**Attention:** With conversion to a different unit, the totalizer increment is calculated with the new unit and added to the previous totalizer status, creating

**Mixed values**

Therefore, resetting the totalizer is logical after a conversion.

In addition, it is also possible to shift the decimal separator and select the "Totalizer status" representation \* 10 (100, 1000) m<sup>3</sup>.

In coordinate **LK22 Counters mode**, the operating mode of the main totalizers is adjusted in case of an alarm:

"Stops" = main totalizer stops in case of an alarm

"Runs" = main totalizer continues to run in case of an alarm  
(in addition to the disturbance totalizers)

"MID" = the totalizer totalizer with volume at base conditions and energy flow stops with an alarm. The volume at meas. cond. continues with an alarm, insofar as the volume transmitter is not affected by a failure. If there is a failure of the pressure or temperature sensor, the volume at meas. cond. continues, and the volume at base conditions stops. Therefore, retroactive accounting is possible, but it can be very elaborate. Therefore, this selection is not preferential and is unusual.

When the value in coordinate **LK23 Max. accumulation** input pulses which have not been converted (i.e. too many intermediately stored pulses with open calibration lock), a message is output:

**W05-7 Pulse batt>max.**

The determination method for the channel status of the totalizers (DSfG function) is defined in **LK26 Channel status method**:

- a.) RMG traditional
- b.) New definition according to Ruhrgas

with **Method a.)**, all stationary counters have the **stopped** status, regardless of whether there is a fault or another route. Only the running counter has the **okay** status.

with **Method b.)**, all counters have the **stopped** status and all main totalizers have the **okay** status in normal operation, regardless of whether they are running or not or whether another route is active. In case of an fault, all disturbance totalizers have the okay status and all main totalizers have the stopped status, regardless of whether they are running or not or whether another route is active.

**LP Setting totalizers**

Access Line	Designation	Value	Unit	Variable	
Q	2	Vb1	-1.000000	*100 m3	setVn1
Q	3	Vc1	-1.000000	m3	setVk1
Q	4	Vm1	-1.000000	m3	setVu1
Q	5	E1	-1.000000	MWh	setE1
Q	6	M1	-1.000000	*100 kg	setM1
Q	7	Vb2	-1.000000	*100 m3	setVn2
Q	8	Vc2	-1.000000	m3	setVk2
Q	9	Vm2	-1.000000	m3	setVu2
Q	10	E2	-1.000000	MWh	setE2
Q	11	M2	-1.000000	*100 kg	setM2
Q	12	Vb3	-1.000000	*100 m3	setVn3
Q	13	Vc3	-1.000000	m3	setVk3
Q	14	Vm3	-1.000000	m3	setVu3
Q	15	E3	-1.000000	MWh	setE3
Q	16	M3	-1.000000	*100 kg	setM3
Q	17	Vb4	-1.000000	*100 m3	setVn4
Q	18	Vc4	-1.000000	m3	setVk4
Q	19	Vm4	-1.000000	m3	setVu4
Q	20	E4	-1.000000	MWh	setE4
Q	21	M4	-1.000000	*100 kg	setM4
Q	22	DVb1	-1.000000	*100 m3	setSVn1
Q	23	DVc1	-1.000000	m3	setSVk1
Q	24	DVm1	-1.000000	m3	setSVu1
Q	25	DE1	-1.000000	MWh	setSE1
Q	26	DM1	-1.000000	*100 kg	setSM1
Q	27	DVb2	-1.000000	*100 m3	setSVn2
Q	28	DVc2	-1.000000	m3	setSVk2
Q	29	DVm2	-1.000000	m3	setSVu2
Q	30	DE2	-1.000000	MWh	setSE2
Q	31	DM2	-1.000000	*100 kg	setSM2
Q	32	DVb3	-1.000000	*100 m3	setSVn3
Q	33	DVc3	-1.000000	m3	setSVk3
Q	34	DVm3	-1.000000	m3	setSVu3
Q	35	DE3	-1.000000	MWh	setSE3
Q	36	DM3	-1.000000	*100 kg	setSM3
Q	37	DVb4	-1.000000	*100 m3	setSVn4
Q	38	DVc4	-1.000000	m3	setSVk4
Q	39	DVm4	-1.000000	m3	setSVu4
Q	40	DE4	-1.000000	MWh	setSE4
Q	41	DM4	-1.000000	*100 kg	setSM4
Q	42	Controlcnt. 1	-1.000000	[]	setcz1
Q	43	Controlcnt. 2	-1.000000	[]	setcz2
Q	44	Controlcnt. 3	-1.000000	[]	setcz3
Q	45	Controlcnt. 4	-1.000000	[]	setcz4

Q	45	Controlcnt. 4	-1.000000	[]	setcz4
Q	46	Extracnt. 1	-1.000000	[]	setez1
Q	47	Extracnt. 2	-1.000000	[]	setez2
Q	48	Extracnt. 3	-1.000000	[]	setez3
Q	49	Extracnt. 4	-1.000000	[]	setez4
Q	50	Extracnt. 5	-1.000000	[]	setez5
Q	51	Extracnt. 6	-1.000000	[]	setez6
Q	52	CO2-EM 1	-1.000000	*100 kg	setCC1
Q	53	CO2-EM 2	-1.000000	*100 kg	setCC2
Q	54	CO2-EM 3	-1.000000	*100 kg	setCC3
Q	55	CO2-EM 4	-1.000000	*100 kg	setCC4
Q	56	Dist. CO2-EM 1	-1.000000	*100 kg	setSCC1
Q	57	Dist. CO2-EM 2	-1.000000	*100 kg	setSCC2
Q	58	Dist. CO2-EM 3	-1.000000	*100 kg	setSCC3
Q	59	Dist. CO2-EM 4	-1.000000	*100 kg	setSCC4
Q	60	Vx1	-1.000000	*100 m3	setVx1
Q	61	Vx2	-1.000000	*100 m3	setVx2
Q	62	Vx3	-1.000000	*100 m3	setVx3
Q	63	Vx4	-1.000000	*100 m3	setVx4
Q	64	DVx1	-1.000000	*100 m3	setSVx1
Q	65	DVx2	-1.000000	*100 m3	setSVx2
Q	66	DVx3	-1.000000	*100 m3	setSVx3
Q	67	DVx4	-1.000000	*100 m3	setSVx4
Y	99	Task		Idle	setAufgabe

Enter Cancel Load defaults Refresh

**Figure 48: Menu LP Set totalizers**

The values of the different totalizers and their remainder can be set in coordinates **LP02 Vc1** to **LP67 DVx4** (e.g. Vc1 and Vc1R, etc.). A negative value means that this totalizer is not set.

The coordinate LP99 Task defines the various assignments that can be viewed in the table below.

<b>Idle</b>	Nothing happens!
<b>All TOT = 0</b>	All totalizers (main+disturbance) and remainder are set to 0. The totalizers are also set to 0 for undefined billing mode.
<b>All DTOT = 0</b>	All disturbance totalizers and remainder are set to 0. The totalizers are also set to 0 for undefined billing mode. The main totalizers remain unaffected
<b>Vm = Vo</b>	All Vm totalizers (uncorrected volume at meas. cond.) are set to the current value of the assigned Vo totalizers (original totalizers). All other totalizers remain unaffected.
<b>Vc = Vm</b>	All Vc totalizers (corrected volume at meas. cond.) are set to the current value of the assigned Vm totalizers (uncorrected volume at meas. cond.). All other totalizers remain unaffected.
<b>Custom</b>	All totalizers that were programmed with a non-negative value in the totalizers settings list are set to this value. In this connection, the portion after the decimal is written to the remainder totalizers. Then the relevant input field in the settings list is set to -1. All totalizers that are negative in the totalizers settings list (explicitly -1) remain unaffected.
<b>all CTOT =0</b>	All control totalizers and remainders are set to 0.
<b>all extra cnt = 0</b>	All extra totalizers are set to 0
<b>All overflows=0</b>	All overflow totalizers are set to 0.
<b>Vx = Vb</b>	All Vx totalizers (undefined totalizers) are set to the current value of the assigned Vb totalizers (volume at base conditions). All other totalizers remain unaffected.

**LV Customer-specific totalizer set A**

Access Line	Designation	Value	Unit	Variable
N	1	Vol. at base cond.	5485 *100 m3	ksVnA
N	2	Vol.base fraction	.453439 *100 m3	ksVnAR
N	3	Vol.at.base ovfl	0	ksOfVnA
N	4	Energy	6669 MWh	ksEA
N	5	Energy fraction	.911436 MWh	ksEAR
N	6	Energy Overflow	0	ksOfEA
N	7	Corr.vol.meas.	10320 m3	ksVxA
N	8	Corr.vol.meas.frac.	.460909 m3	ksVxAR
N	9	Corr.vol.meas.ovfl.	0	ksOfVxA
N	10	Vol. at meas.cond.	10320 m3	ksVuA
N	11	Vol.meas.fraction	.460909 m3	ksVuAR
N	12	Vol.at.meas ovfl	0	ksOfVuA
N	13	Mass	4198 *100 kg	ksMA
N	14	Mass fraction	.304836 *100 kg	ksMAR
N	15	Mass Overflow	0	ksOfMA
N	16	CO2 emission	11483 *100 kg	ksCCA
N	17	CO2 emission frac	.280324 *100 kg	ksCCAR
N	18	CO2 emission ovfl	0	ksOfCCA
N	19	Vol.2nd.base.cond.	0 *100 m3	ksVxA
N	20	Vol.2nd.base.frac	.000000 *100 m3	ksVxAR
N	21	Vol.2nd.base.ovfl	0	ksOfVxA
B	31	Assignm. main/dist.	Undisturbed only	ksAHS
B	32	Assignm. to BM	12	ksAAM
B	33	Description	Kundenzähler-A	ksAText
F	61	Vol. at base cond.	5485 *100 m3	ksVnA
F	62	Vol.base fraction	.453439 *100 m3	ksVnAR
F	63	Energy	6669 MWh	ksEA
F	64	Energy fraction	.911436 MWh	ksEAR
F	65	Corr.vol.meas.	10320 m3	ksVxA
F	66	Corr.vol.meas.frac.	.460909 m3	ksVxAR
F	67	Mass	4198 *100 kg	ksMA
F	68	Mass fraction	.304836 *100 kg	ksMAR
F	69	Vol. at meas.cond.	10320 m3	ksVuA
F	70	Vol.meas.fraction	.460909 m3	ksVuAR
F	71	Vol.2nd.base.cond.	0 *100 m3	ksVxA
F	72	Vol.2nd.base.frac	.000000 *100 m3	ksVxAR

Enter Cancel Load defaults Refresh

**Figure 49: Menu LV Customer-specific totalizers set A**

The customer-specific totalizers have a similar configuration to the "normal" totalizers. In coordinate **LV31 Assignm. main/dist.**, a selection between "Undisturbed only", "Disturbed only " and "Always" can be made for the **Totalizers operation**. With "Only undisturbed", for example, the customer totalizers only run when the ERZ2000-NG status is undisturbed. The selection of totalizers source(s) is made in coordinate **LV32 Assignm. to BM** the customer totalizers run only when Billing mode 1 or 2 is active. A totalizers designation is assigned in coordinate **LV33 Description**.

Menu **LW Customer-specific totalizers set B** is configured analogously to menu LV.

Menu **LX Setting customer-specific totalizers** is comparable to the "normal" setting of totalizers (see above).

2.5.1.6 Flow rate

Name	Value	Unit	Description
Qe	6669.143	kW	Energy flow rate, measured value
Qms	198.221	kg/h	Mass flow rate, measured value
Qb	5485.323	m3/h	Volumetric flow rate at base conditions
Qx	5512.022	m3/h	Flow at extra base condition
Qm	16382.123	m3/h	Volumetric flow rate at measurement conditions, measured value
Qmc	15099.003	m3/h	Corrected volumetric flow rate at measurement conditions, measured value
HFX	382.221	Hz	Volumetric flow rate at measurement conditions, frequency, main

Figure 50: Overview Flow rate sub-menu

This menu shows different flow rates, such as energy flow, volume flow at base conditions and volume flow at measurement conditions or the measured flow. The average flow speed is also displayed.

2.5.1.7 System

Name	Value	Unit	Description
RAM	17477632	Bytes	free available memory
SVN	1219_179_220		SVN revisions
t	13-09-2018 17:50:09		Current date and time
TZ	W. Europe Standard T		Time zone and daylight-saving time rule
IP	10.20.13.71		own IP4-Address on Ethernet 1
IP	160.221.45.110		own IP4-Address on Ethernet 2
	Super user		Current access

Figure 51: Overview System sub-menu

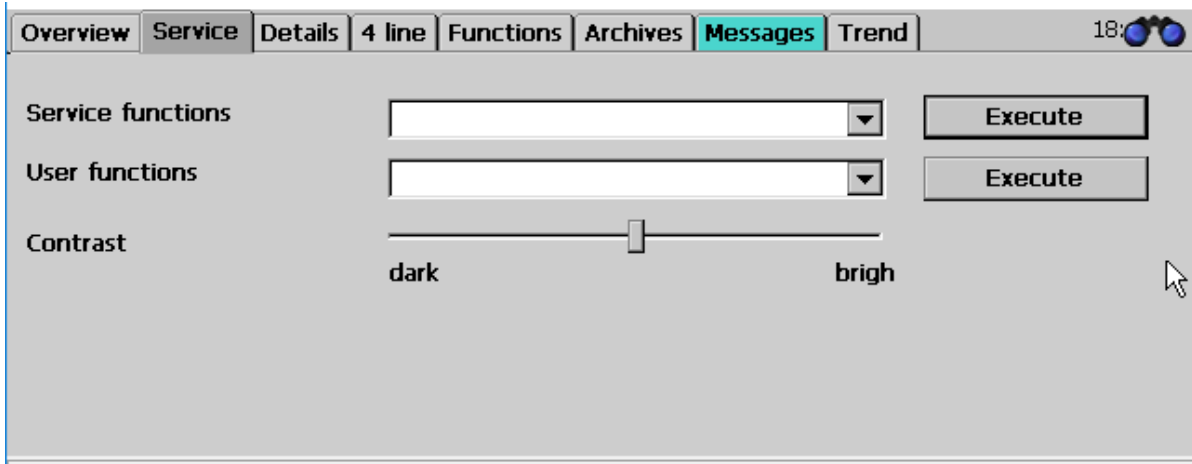
Various general values are displayed here, including the IP addresses with which you can actuate the device if it is connected to the PC via Ethernet. The current addresses can also be found in the Details menu under **I Communication** in coordinates **IA01 own IP-Addr. Eth1** and **IA21 own IP-Addr. Eth2**.

The screenshot shows the web interface for the RMG Messtechnik ERZ 2000-NG. The left sidebar contains a tree view of system sub-menus, with 'IA TCP/IP network' selected and circled in red. The main content area displays the configuration for the IA TCP/IP network as a table with columns: Access Line, Designation, Value, Unit, and Variable. Two values in the table are circled in red: '10.20.13.71' for 'own IP-Addr.Eth1' and '10.20.13.8' for 'own IP-Addr-Eth2'. The table also includes entries for MAC addresses, netmasks, gateways, DNS, and DHCP settings.

Access Line	Designation	Value	Unit	Variable
B 1	own IP-Addr.Eth1	10.20.13.71		my_ipE1
I 12	MAC-address Eth1	00-05-51-05-1A-FC		macAddrE1
B 13	Netmask Eth1	255.255.255.0		netmaskE1
B 14	Gateway Eth1	10.20.13.1		gatewayE1
B 15	DNS Eth1	172.17.248.98		namesrvE1
B 16	DHCP Eth1	No		dhcpE1
B 21	own IP-Addr-Eth2	10.20.13.8		my_ipE2
D 24	GIA-countdown		0 s	giaCntDwn
S 32	MAC-address Eth2	00-00-00-00-00-00		macAddrE2
B 33	Netmask Eth2	255.255.0.0		netmaskE2
B 34	Gateway Eth2	192.168.20.254		gatewayE2

Figure 52: Overview System sub-menu

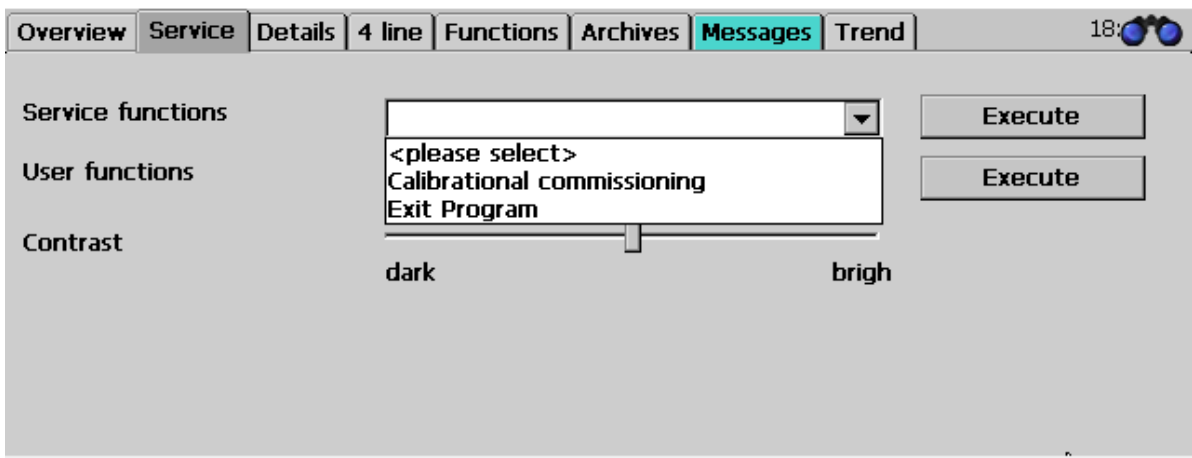
### 2.5.2 Service



69

**Figure 53: Service menu**

If the white field to the right of the "Service functions" is touched, then, the **service functions** "Official custody transfer commissioning" and "Close program can be selected with the **open calibration switch**.



**Figure 54: Menu Service / sub-program "Calibrational commissioning" and "Exit program"**

In order to implement calibrational commissioning of the ERZ2000-NG on site, at the measuring station, a service technician and a calibration official are required.

First, a calibration commissioning (Calibrational commissioning) is initiated with "Execute" in order to reset all parameters of WinCE to the default values (all parameters that are not under the calibration switch). If the ERZ2000-NG application is running, a restart of the kernel is carried out as an essential part of the process and the CRC (cyclic redundancy check) of the complete kernel is calculated and displayed in

the matrix element "Kernel CRC EJ21". The setpoint is displayed in the matrix element "Kernel CRC, EJ22" for comparison.

In order to adopt the newly calculated values according to this service function, an **additional** restart is necessary, which can be initiated via the service function "Exit program" with "Execute" (or by disconnecting the power supply).

70

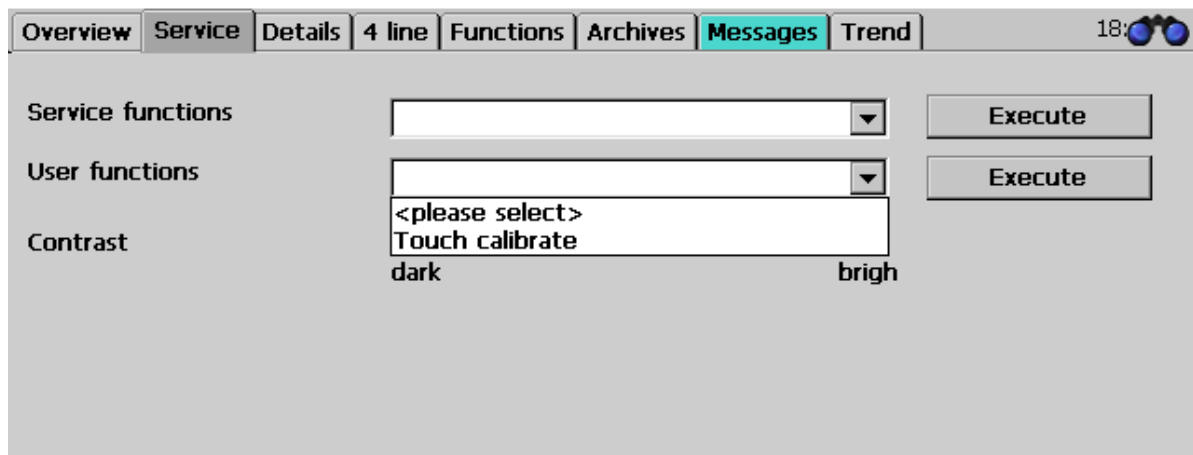
### Note

#### Attention:

In menu E Mode, ED Access to parameters, coordinate ED05 Service mode must be set to the default value "no".

The setting "yes" is reserved for the service department when settings should be made in WinCE.

After a restart, the calibration official checks the CRC; if the check is successful, the calibration switch is closed and the device is sealed by the calibration official. Then the final setup of the ERZ2000-NG can take place. In the process, the network settings and time zone are stored in the device. The device is ready for operation when all necessary settings have been made.



**Figure 55: "Touch calibrate" service menu / sub-program**

If a blur occurs on contact of the stylus with the touchscreen, calibration can take place in the "Touch calibrate" menu item under functions. After the function starts a series of crosses that must be touched in the center is displayed. This calibration can take place at any time. The **contrast** can also be changed in the service menu at any time. The touch calibration can also be activated by pressing the home button on the overview page and drawing a line covering about 1/3 of the screen width. Then the touch calibration opens automatically.



### 2.5.3 Details

A list of all measurements, computed values, calculated variables, parameters, functions and operating modes is provided here. The data is shown in a structure like in the display with an internet browser; as viewed from the left, you see the superordinate menu **tree**, which can be opened by "clicking" with the stylus on the touchscreen or by clicking with the right mouse pointer in the PC display for the sub-menus. *Figure 56: Details menu* shows the screen.

Select		Xs	Zl	Name	Value	Unit
[-] A	Measured values	A*	1	Measured value	0.55000	MPa
[-] AB	Absolute pressure	A*	2	Input value	0.55000	MPa
[-] AC	Gas temperature	E*	3	Operating mode	Default	
[-] AD	Sup.calorific val.	G*	4	Unit	MPa	
[-] AE	Standard density	B	5	Default	0.55000	MPa
[-] AF	Relative density	B	6	Lower warning limit	0.10000	MPa
[-] AG	Density	B	7	Upper warning limit	1.00000	MPa
[-] AH	Dens.transd.temp.	E*	8	Lower alarm limit	0.10000	MPa
[-] AI	VOS temperature	E*	9	Upper alarm limit	1.00000	MPa
[-] AJ	Vel. of sound(M)	E*	10	Coefficient 0	0	
		E*	11	Coefficient 1	0	
		E*	12	Coefficient 2	0	

Figure 56: Details menu

Chapter 2.1.3 Remote control / parameterization explains how parameters can be changed. Information about the individual parameters is also listed here or in the special chapters (chapter: 4.2 Pressure transducer, 4.3 Temperature transducer, 5 Flow meters and 6 Parameter of the gas).

### 2.5.4 4 Lines

The "4 Lines" interface offers the user a second operating variant.

OTFC	At rest
Vm	.0000 m3
Vc	.0000 m3
Vb	.0000 *100 m3

Control Panel: 1 (Meas.PT.), 2 (Analysis), 3 (Orifice), 4 (I/O), 5 (Archive), 6 (Test), 7 (Totalizer), 8 (Flow-rates), 9 (Meter), 0 (Mode), ID, Select, Alarms Clear

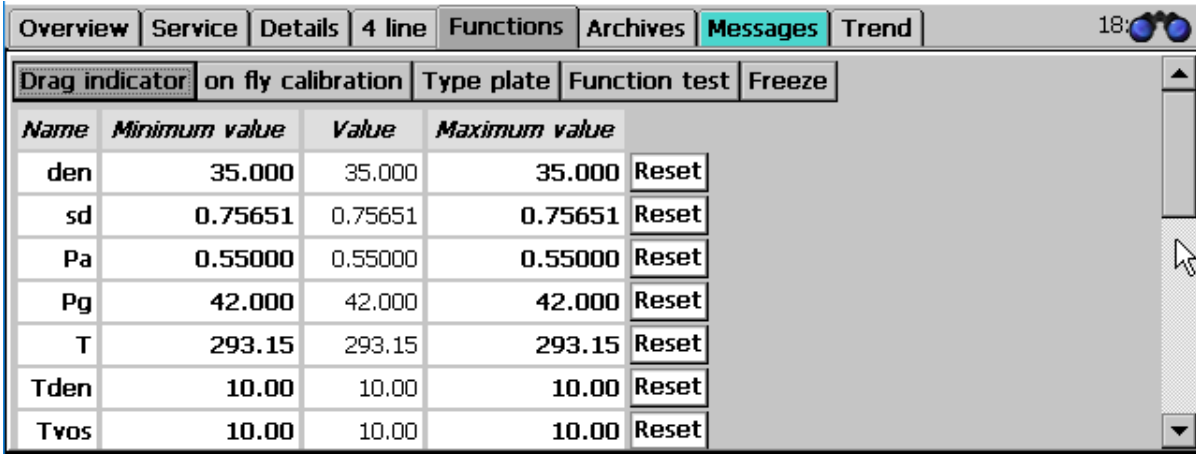
Figure 57: "4 Lines" menu

Those accustomed to operating an ERZ2000 with device buttons have the possibility of also operating the ERZ2000-NG in this manner with this screen. The 4-line display of the ERZ2000 is also shown here. If operation via this "4 Lines" menu is selected, refer to the ERZ2000 manual in case of any questions. This manual can be downloaded as necessary via the homepage [www.rmg.com](http://www.rmg.com).

72

You can switch back and forth between the column selection menu and the matrix with the "\*" button (selection). The arrow keys enable navigation in the menu as well as the matrix.

## 2.5.5 Functions



Name	Minimum value	Value	Maximum value	
den	35.000	35.000	35.000	Reset
sd	0.75651	0.75651	0.75651	Reset
Pa	0.55000	0.55000	0.55000	Reset
Pg	42.000	42.000	42.000	Reset
T	293.15	293.15	293.15	Reset
Tden	10.00	10.00	10.00	Reset
Tvos	10.00	10.00	10.00	Reset

**Figure 58: "Drag pointer" sub-menu under "Functions"**

The "Functions" menu opens 5 additional sub-menus, which are listed below.

### 2.5.5.1 Drag pointer

The absolute minimum and maximum values for the measurements since the last restart or since the last resetting of the drag pointer are shown here. The function is defined in coordinates **XX31 Min. drag pointer** and **XX32 Max. drag pointer**. In the process, **XX** stands for the values and parameters for which this function is available. These values specified for the "drag pointer" are deleted with "Reset" and then the set to the current measurement. The display is shown in *Figure 58: "Drag pointer" sub-menu under "Functions"*. The drag pointers can also be reset globally in the **EM erasing procedure** menu.

Depending on the mode selected in **EI27 Drag indicator mode**, the drag pointer is calculated from the conversion of the used measurement or the original measurement.

If display of the drag pointer is not desired, the appropriate setting can be made under **EI16 Drag indic. active**.

### 2.5.5.2 On-the-fly calibration

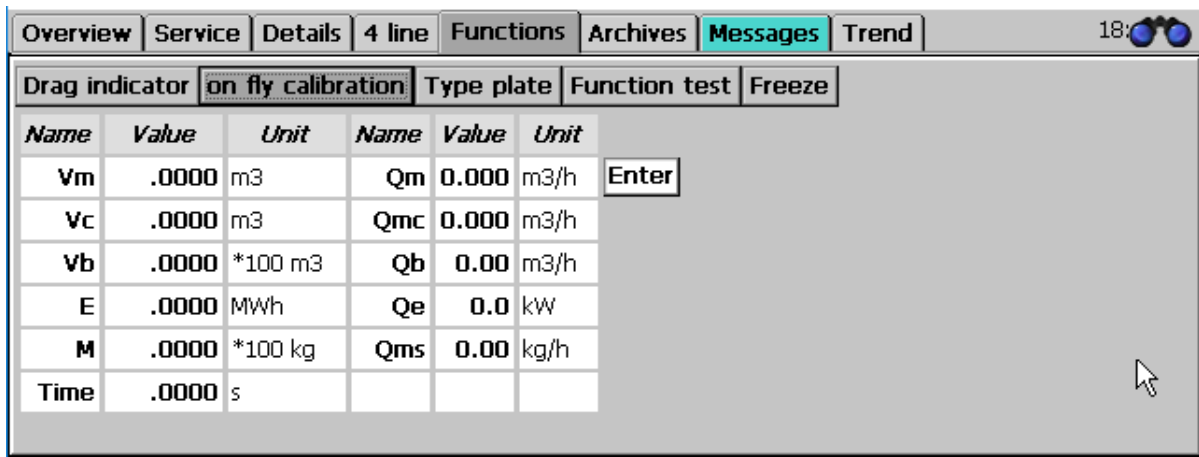


Figure 59: "On-the-fly calibration" sub-menu under "Functions"

Totalizers that can be started like a stopwatch at 0 are shown in this screen. **It is started with "Enter" – to the right of the values.** The totalizers then run until "Enter" is pressed again. Pressing "Enter" again resets the totalizers to 0 and initiates a restart.

### 2.5.5.3 Type plate

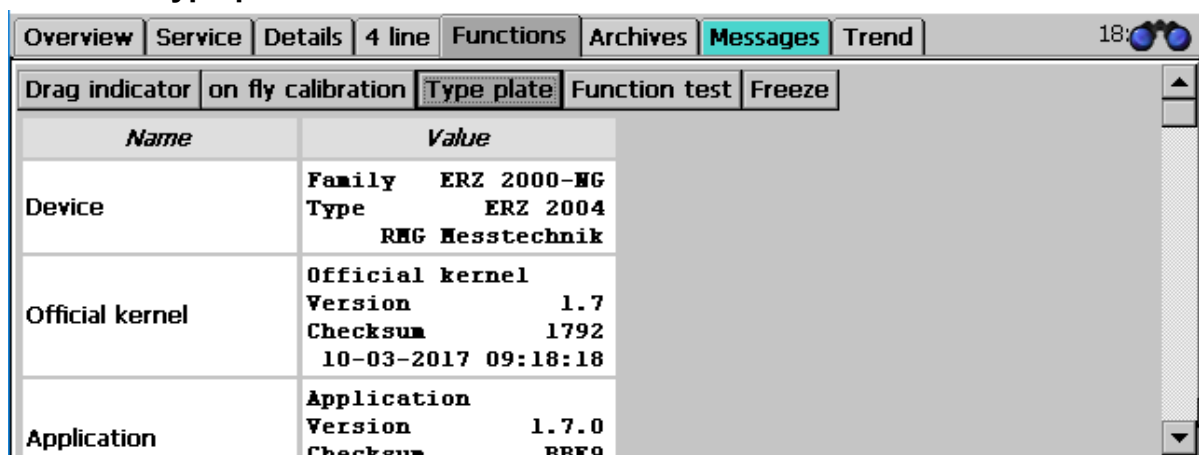


Figure 60: "Type plate" sub-menu under "Functions"

The type plate of the device is displayed in the "Type plate" submenu. This included further data, e.g. about the electronics (calibration kernel, Bios, WinCE kernel), about the totalizers and their settings (dimensions, pulse value), about the type of gas (composition, velocity of sound) and the environmental and base conditions (pressure, temperature).

The type plate data is only displayed here; there is no input possibility in the type plate display. Entry of the values takes place by entering the parameters of the relevant transmitter devices (*chapter "4 Transmitters"*)

The type plate can also be viewed in the browser under the menu **EG Type plate**.

**EG ID display**

Access Line	Designation	Value	Unit	Variable
A *	1 Device	Family ERZ 2000-NG Type ERZ 2004 RMG Messtechnik		<a href="#">gerTyps</a>
A *	2 Official kernel	Official kernel Version 1.7 Checksum 1792 10-03-2017 09:18:18		<a href="#">ekTyps</a>
A *	3 Application	Application Version 1.7.0 Checksum BBE9 10-03-2017 09:18:18		<a href="#">apTyps</a>
...				
A *	33 TCP/IP Eth1	TCP/IP Eth1 IP 10.20.13.71 NM 255.255.255.0 GW 10.20.13.1		<a href="#">tcpTypsEth1</a>
A *	34 TCP/IP Eth2	TCP/IP Eth2 IP 160.221.45.110 NM 255.255.0.0 GW 192.168.20.254		<a href="#">tcpTypsEth2</a>
A *	35 DSfG	DSfG Entity U2 Address OFF CRC12 123		<a href="#">dsfgTyps</a>
A *	36 Location	Location Gas1 p5 Line 1 Main measurement		<a href="#">ortTyps</a>

Refresh

**Figure 61: EE Type plate menu**

2.5.5.4 Revision

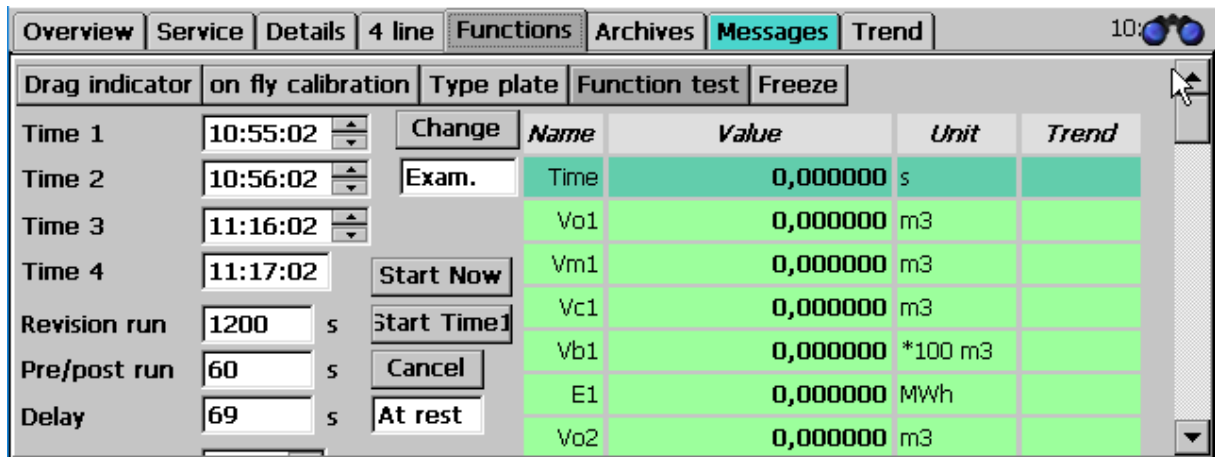


Figure 62: "Revision" sub-menu under "Functions"

The quantities and measurements are recorded and displayed for a defined length of time in the functional test. The revision is divided into a run-up, the actual test and an after-run.

**Revision process:**

1. Enter four times for the three sections of the revision.
2. Click on "Start Time1". Then the revision is run according to the four times. Times that have already elapsed are highlighted green.
3. The result can be read in the green highlighted table to the right. You can switch back and forth between the tables for run-up, test and after-run with "Change".

Alternatively, the times for test time, run-up and after-run, as well as a delay time can be entered. The results of the revision are also saved in archive groups 17 to 20.

The revision can be carried out at the same time in a partner device (ERZ2000 or ERZ2000-NG) which is connected to the same DSfG bus. For this purpose, the appropriate DSfG address of the partner device must be entered.

### FF Function test under running conditions

Access Line	Designation	Value	Unit	Variable
D 1	Revision status	At rest		<a href="#">revStat</a>
Q 2	Time stamp 1	01-01-1970 01:00:00		<a href="#">revStamp1</a>
Q 3	Time stamp 2	01-01-1970 01:00:00		<a href="#">revStamp2</a>
Q 4	Time stamp 3	01-01-1970 01:00:00		<a href="#">revStamp3</a>
Q 5	Time stamp 4	01-01-1970 01:00:00		<a href="#">revStamp4</a>
Q 6	Revision run	1200	s	<a href="#">revPrf</a>
Q 7	Pre/post run	60	s	<a href="#">revVorNach</a>
Q 8	Delay	1	s	<a href="#">revDelay</a>
B 9	Partners address	OFF ▾		<a href="#">partner</a>
B 10	Partners entity	Flow comp. entity ▾		<a href="#">partInst</a>
C 11	Code 1 of partner	9999		<a href="#">bpcode1</a>
C 12	Code 2 of partner	9999		<a href="#">bpcode2</a>

Enter   Cancel   schedule   Refresh

#### [Result of function test](#)

**Figure 63: Menu FF Revision**

In order to receive logical values with appropriate resolution, an adequate test time must be provided. A few minutes are sufficient for the volume detection via the HF inputs, because synchronization of the test function with the recording of the volume frequency takes place. For "slow" inputs, such as interfaces with ENCO or ultrasonic gas meters, the test time must be sufficiently long to minimize resolution error (1000 seconds). This also applies for the "On-the-fly calibration" function.

The coordinates of the menu in detail:

- FF01 Revision status**      Shows the current status of the function (at rest / running)
- FF02 Time stamp 1**      Parameter for starting the test process (run-up start)
- FF03 Time stamp 2**      Parameter for stopping the run-up and starting the test
- FF04 Time stamp 3**      Parameter for stopping the test and starting the after-run
- FF05 Time stamp 4**      Parameter for stopping the after-run and the function
- FF06 Revision run**      Parameter for a relative default of the test time, corresponding to the time between Time stamp 3 and 4

<b>FF07 Pre/post run</b>	Parameter for a relative specification of the run-up and after-run time, corresponding to the time between Time stamp 1 and 2 or 3 and 4
<b>FF08 Delay</b>	Parameter for a wait time before the start with Time stamp 1

There are multiple processes for using the revision function.

**Use of the time stamp with manual entry.**

If the 4 time stamps are entered, activate the "Start Time1" button. Then the function starts automatically when the times are reached and stops after the 4th time stamp has elapsed. The test time, the time for run-up/after-run and the delay are calculated and adopted from these times. There is also an option for activating an revision directly by clicking on the "Start now" button. For this purpose, the test time and run-up/after-run must be specified beforehand.

**Use of the time stamp with input via the DSfG from the revisioning PC.**

If the 4 time stamps are entered, the function starts automatically after the times are reached and stops after the expiration of the 4th time stamp. The test time, the run-up/after-run and delay time have no effect.

**Parameterization of the time stamp with entry by means of remote operation via the browser.**

For this purpose, click on the "schedule" button under the table. The 4 time stamps are calculated from the PC time (not the flow computer time!) and the values for test time, run-up/after-run and delay. The function starts automatically when the times are reached and stops after the 4th time stamp has elapsed.

The prior function of the DSfG revision is merged with the official custody transfer revision. The result of a completed revision can be viewed in the browser.

**Note**

**The summary of the archive cannot be viewed with a representation in the 4 lines of the display and the values must be written down. In addition, the representation of data elements of archive groups 11, 12 and 13 takes getting used to.**

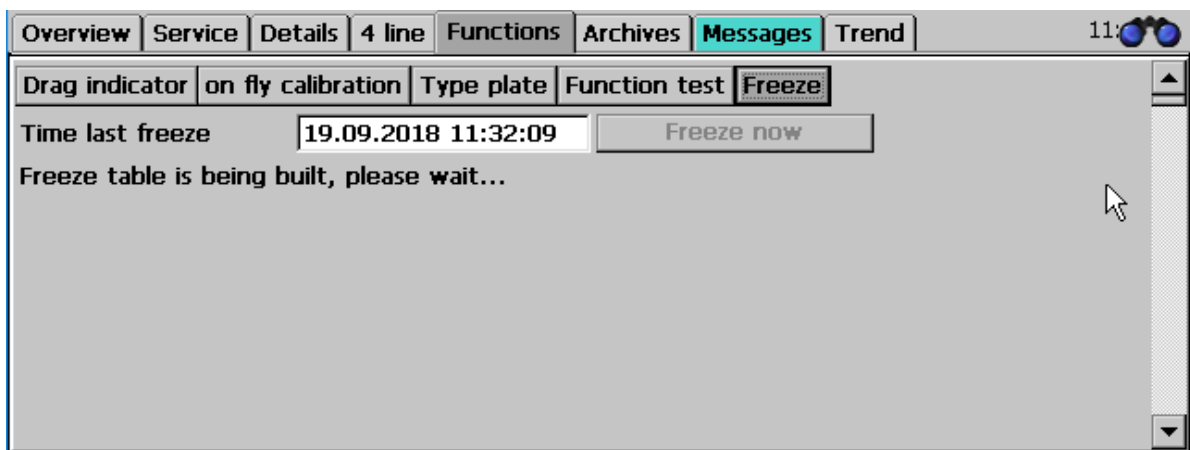
Designation	Pre run		Examination				Post run		Unit	Trend
	19-09-2018 16:01:26	-	19-09-2018 16:01:36	-	19-09-2018 16:02:36	-	19-09-2018 16:02:46			
Time	6400.967663	10.000063	<b>6410.967726</b>	<b>59.999539</b>	<b>6470.967265</b>	9.999886	6480.967151	s		
Vo1	43044.898303	0.326637	<b>43045.224940</b>	<b>1.959824</b>	<b>43047.184764</b>	0.326637	43047.511401	m3		
Vm1	43044.898303	0.326637	<b>43045.224940</b>	<b>1.959824</b>	<b>43047.184764</b>	0.326637	43047.511401	m3		
Vc1	1354410.397590	12.228196	<b>1354422.625786</b>	<b>73.369174</b>	<b>1354495.994960</b>	12.228188	1354508.223148	m3		
E1	24540.539483	0.122184	<b>24540.661667</b>	<b>0.733105</b>	<b>24541.394771</b>	0.122184	24541.516955	MWh		
Vo2	0.000000	0.000000	<b>0.000000</b>	<b>0.000000</b>	<b>0.000000</b>	0.000000	0.000000	m3		
Vm2	0.000000	0.000000	<b>0.000000</b>	<b>0.000000</b>	<b>0.000000</b>	0.000000	0.000000	m3		
Vc2	0.000000	0.000000	<b>0.000000</b>	<b>0.000000</b>	<b>0.000000</b>	0.000000	0.000000	m3		
E2	0.000000	0.000000	<b>0.000000</b>	<b>0.000000</b>	<b>0.000000</b>	0.000000	0.000000	MWh		
Qm		117,589		<b>117,589</b>		117,589		m3/h		
Qmc		117,589		<b>117,589</b>		117,589		m3/h		
Qb		4402.15		<b>4402.15</b>		4402.15		m3/h		
Qe		43986.2		<b>43986.3</b>		43986.3		kW		
P		35,000		<b>35,000</b>		35,000		bar		
T		0.13		<b>0.13</b>		0.13		°C		
Hs		9,992		<b>9,992</b>		9,992		kWh/m3		
sd		0.7768		<b>0.7768</b>		0.7768		kg/m3		
Den		29,081		<b>29,081</b>		29,081		kg/m3		
Vsm		431,100		<b>431,100</b>		431,100		m/s		
C		37.4366		<b>37.4366</b>		37.4366				
K		0.92223		<b>0.92223</b>		0.92223				
CO2		6,200		<b>6,200</b>		6,200		mol-%		
H2		0,000		<b>0,000</b>		0,000		mol-%		
N2		10,000		<b>10,000</b>		10,000		mol-%		
CH4		83,800		<b>83,800</b>		83,800		mol-%		
C2H6		0,000		<b>0,000</b>		0,000		mol-%		
C3H8		0,000		<b>0,000</b>		0,000		mol-%		
N-C4		0,000		<b>0,000</b>		0,000		mol-%		
I-C4		0,000		<b>0,000</b>		0,000		mol-%		
N-C5		0,000		<b>0,000</b>		0,000		mol-%		
I-C5		0,000		<b>0,000</b>		0,000		mol-%		
NeoC5		0,000		<b>0,000</b>		0,000		mol-%		
C6		0,000		<b>0,000</b>		0,000		mol-%		
C7		0,000		<b>0,000</b>		0,000		mol-%		
C8		0,000		<b>0,000</b>		0,000		mol-%		
C9		0,000		<b>0,000</b>		0,000		mol-%		
C10		0,000		<b>0,000</b>		0,000		mol-%		
H2S		0,000		<b>0,000</b>		0,000		mol-%		
H2O		0,000		<b>0,000</b>		0,000		mol-%		
He		0,000		<b>0,000</b>		0,000		mol-%		
O2		0,000		<b>0,000</b>		0,000		mol-%		
CO		0,000		<b>0,000</b>		0,000		mol-%		
C2H4		0,000		<b>0,000</b>		0,000		mol-%		
C3H6		0,000		<b>0,000</b>		0,000		mol-%		
Ar		0,000		<b>0,000</b>		0,000		mol-%		



The center row with 3 columns and the examination heading (bold) is the result of the revision. The first column displays the initial values, the center column the differences and averages and the third column the stop values. Run-up and after-run are relevant data depending on the logical examination times.

The revision then delivers usable data if the flow computer runs error-free and does not change during the examination of the totalizer status (running / at rest). If this is not the case, the starting and stopping values are not displayed and the lines with the totalizer statuses are hidden. If, for instance, only the disturbance totalizers are running, the stationary main totalizers are stored with the difference = 0. For interface protocols that only send the data in second-long intervals, the test time must be given more attention (ENCO, DZU). The same also applies for LF inputs.

### 2.5.5.5 Freeze



**Figure 64: "Freeze" sub-menu under "Functions"**

The ERZ2000-NG offers the option of temporarily storing current data for later use. This is referred to as a freeze. The last quantities and measurements are "frozen" with the freeze function. First, the ERZ2000-NG reports the recording of all data and the configuration of the table. This can take several seconds, then the data that was recorded on the specified date and time.

A freeze is most easily activated by pressing the "Freeze now" button.

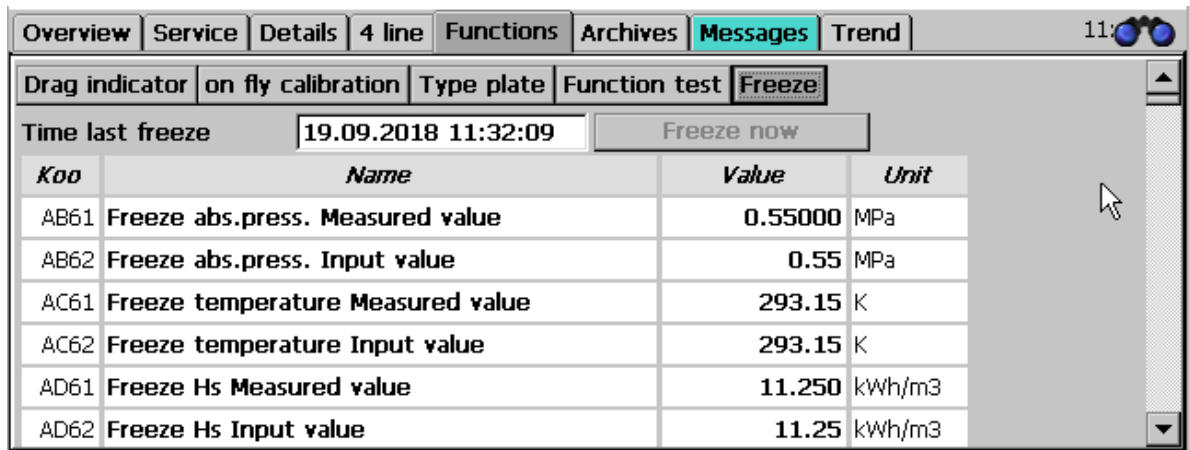


Figure 65: "Freeze" sub-menu under "Functions"

Figure 66: Menu FC Freeze shows the submenu **FC Freeze** under "F Test". **FC01 Time last freeze** shows the time of the last archiving, coordinates **FC03** to **FC05** can be used to adjust when and how the freeze function is activated. **FC04** defines the freeze time interval over which the data is recorded and archived. In coordinate **FC05 Source freeze cont.** the corresponding contact input 1 to 8 must be set if a "Freeze" should be initiated by a contact pulse.

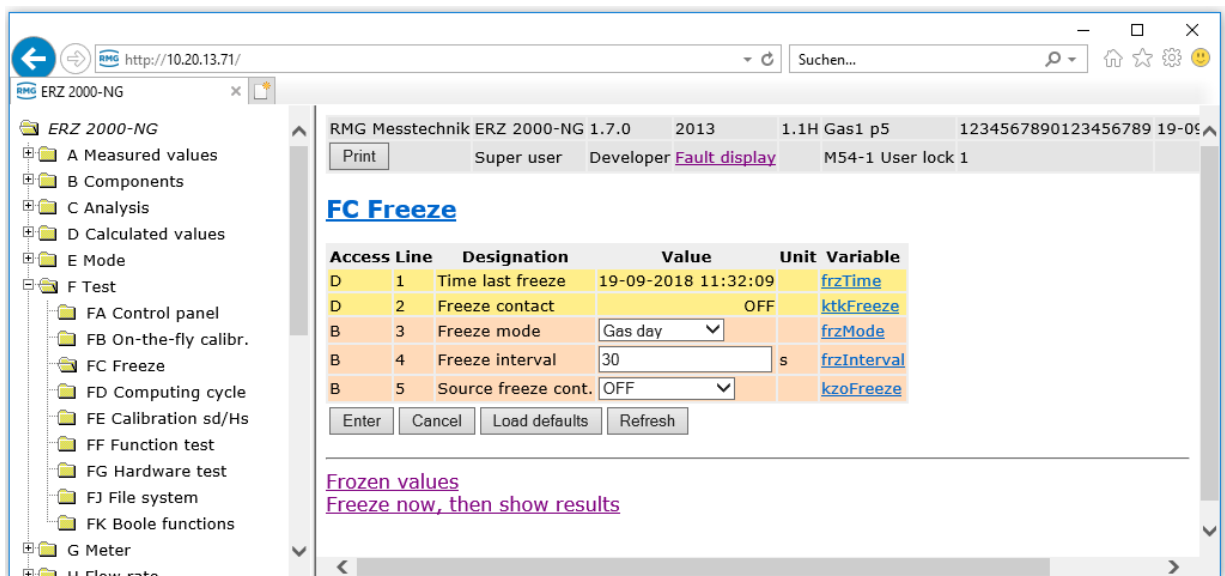


Figure 66: Menu FC Freeze

The selection of how frequently the freeze process is initiated (**FC03 Freeze mode**) is:

Off	No freeze processes are triggered
Every second	Freeze in second intervals
Every minute	Freeze in minute intervals at the start of a minute
Every hour	Hourly freezing at the start of an hour
Every day	Daily freeze at the start of the day
Gas day	Freeze is initiated on the specified gas day ("KA27 Gas day") at the beginning of the specified billing hour ("KA 14 Billing hour"). The billing hour must be specified; day, month and year are specified automatically.
Cyclical	Cyclical freeze in the specified interval (coordinate "FC04 Freeze interval")
Contact	Trigger freeze with a selectable contact input
Manually	e.g. Freeze is triggered with button via contact input 2.
Every month	Monthly freeze on 1st day of each month
Gas month	The freeze is initiated in the specified month (coordinate "KA28 Gas month") at the beginning of the specified billing hour (coordinate KA 14) and specified day (coordinate "KA27 Gas day"). The billing hour and day must be specified; month and year are specified automatically.
DSfG	The "Freeze" is triggered via the DSfG bus.

The freeze results can be displayed in the browser (function under the menu **FC Freeze**). They are stored in the blue fields.

**Frozen values**

**Date and time of last freeze : 19-09-2018 11:32:09**

**AB Freeze absolute pressure**

61	Freeze measured value for absolute pressure	0.55000	MPa
62	Freeze input value for absolute pressure	0.55	MPa

**AC Freeze temperature**

61	Freeze measured value for temperature	293.15	K
62	Freeze input value for temperature	293.15	K

**AD Freeze superior calorific value**

61	Freeze measured value for superior calorific value	11.250	kWh/m3
62	Freeze input value for superior calorific value	11.25	kWh/m3

**AE Freeze standard density**

61	Freeze measured value for standard density	0.75651	kg/m3
62	Freeze input value for standard density	0.75651	kg/m3

**Figure 67: Display of the last freeze values**


## 2.5.6 Archive

The archive entries of all archive groups can be viewed in this screen. The entries are numbered from "Start" to "End", where the initial value is set to 1. If the index has reached the maximum buffer depth, the oldest entry is overwritten when a new data record is generated starting at this point. Then the start index increases by 1 each time.

### Note

Only display is possible on the device; the archive content can also be exported in the Excel-compatible tsv format with the internet browser.

Transmission of data line-by-line to the Excel-tsv format is also possible. Consequently, data with the same time stamp (same) line is transmitted before an update and older data is updated and overwritten as necessary.

Overview	Service	Details	4 line	Functions	Archives	Messages	Trend	11: 
AG1 cnt+meas BM1								
19.09.2018 11:00:00								
Search								
Start=4717								
End=12908								
Order-No		12908						
+1	+10	+100	+1000					
-1	-10	-100	-1000					
<input type="checkbox"/> autom. refresh								

Name	Value	Unit
* Totalizer BM1 / Corr.vol.meas.	111118	m3
* Totalizer BM1 / Vol. at base cond.	76810	*100 m3
General DSfg / Own bit string	00000000	hex
* Totalizer BM1 / Vol. at meas.cond.	111118	m3

Figure 68: "Archive"

### Call-up of archive data

The desired archive group (AG) is selected at the top left. A search time can be entered in the field below it. After pressing "Search", the entry is displayed to the right with this date and time.

### Note

If no entry exists with this time, the next newest data record is displayed.

Two fields for jumping to the oldest or newest entry are included. The indenture number indicates the current position, i.e. the index of the displayed entry. Jumps of  $\pm 1$ ,  $\pm 10$ ,  $\pm 100$  and  $\pm 1000$  positions can be made with the fields below.

The display can be automated so that the last stored value is always displayed. For this purpose, the last data record (end) must be selected first, then the function "Autom. refresh" must be activated. If the newest data record is not displayed, the check box is deactivated and meaningless. "End" must be actuated before the automation is reactivated. The actualization process is displayed with a blinking of the background color of the check box. In the process, color-coding differentiates between updating and updating and display of a new data record.

The values in the table can have different background colors:

White		Fault-free measurement
Gray		Totalizer/measurement has stopped
Blue		Substitute value
Green		Fixed value

**It is possible to freely define a special archive. The content and recording cycle can be selected arbitrarily by the user. The complete scope of all measurements and values are available via a selection menu for the storage of data, comparable to the selection for the current outputs (Figure 69: Free programmable archive).**

Parameterization of the archive content takes place under **OU Free programmable archive**. The appropriate coordinate to be archived must be selected under **OU10 Assign. Channel 1** for selection of content. For example, [AD01](#) is available as a factory setting; this coordinate is assigned to the calorific value. Any other arbitrary value can be assigned via a selection menu. Up to 20 coordinates can be assigned in this manner. Entry for the user code is suitable for access.

The ERZ2000-NG writes the result-controlled (e.g. with incoming and outgoing errors or with full hours or ..) totalizer statuses, measurements and messages in its archive. For this purpose, there are different archives, e.g. for main totalizers, disturbance totalizers or special measurements. It also determines the highest values from the measurements, which are displayed and written to the appropriate archive groups.

The time grids are adjustable with the coordinate **OU01 Record cycle**:

Off, every minute, every 2<sup>nd</sup> minute, every 3<sup>rd</sup> minute, every 4<sup>th</sup> minute, every 5<sup>th</sup> minute, every 6<sup>th</sup> minute, every 10<sup>th</sup> minute, every 12<sup>th</sup> minute, every 15<sup>th</sup> minute, every 20<sup>th</sup> minute, in minute 30, every hour, every day, gas day, every month, gas month, on ever freeze cycle and on every change of the gas composition.

**The archive depth is 8192 entries.**

**OU Free programmable archive**

Access Line	Designation	Value	Unit	Variable
B	1	Record cycle	OFF	fpagZyk
B	10	Assign.Channel 1 = <a href="#">AD01</a> <a href="#">Edit</a>	kWh/m3	fpagk1
B	11	Assign.Channel 2 = <a href="#">AE01</a> <a href="#">Edit</a>	kg/m3	fpagk2
B	12	Assign.Channel 3 = <a href="#">LB10</a> <a href="#">Edit</a>	m3	fpagk3
B	13	Assign.Channel 4 = <a href="#">LC04</a> <a href="#">Edit</a>	MWh	fpagk4
B	14	Assign.Channel 5 = <a href="#">LC01</a> <a href="#">Edit</a>	*100 m3	fpagk5
B	15	Assign.Channel 6 = <a href="#">OC01</a> <a href="#">Edit</a>		fpagk6
B	16	Assign.Channel 7 = <a href="#">LB07</a> <a href="#">Edit</a>	m3	fpagk7
B	17	Assign.Channel 8 = <a href="#">LD01</a> <a href="#">Edit</a>	*100 m3	fpagk8
B	18	Assign.Channel 9 = <a href="#">LD10</a> <a href="#">Edit</a>	m3	fpagk9
B	19	Assign.Channel 10 = <a href="#">LE04</a> <a href="#">Edit</a>	MWh	fpagk10
B	20	Assign.Channel 11 = <a href="#">LE01</a> <a href="#">Edit</a>	*100 m3	fpagk11
B	21	Assign.Channel 12 = <a href="#">LE10</a> <a href="#">Edit</a>	m3	fpagk12
B	22	Assign.Channel 13 = <a href="#">HB01</a> <a href="#">Edit</a>	kW	fpagk13
B	23	Assign.Channel 14 = <a href="#">HD01</a> <a href="#">Edit</a>	m3/h	fpagk14
B	24	Assign.Channel 15 = <a href="#">HE01</a> <a href="#">Edit</a>	m3/h	fpagk15
B	25	Assign.Channel 16 = <a href="#">AB01</a> <a href="#">Edit</a>	MPa	fpagk16
B	26	Assign.Channel 17 = <a href="#">AC01</a> <a href="#">Edit</a>	K	fpagk17
B	27	Assign.Channel 18 = <a href="#">AD01</a> <a href="#">Edit</a>	kWh/m3	fpagk18
B	28	Assign.Channel 19 = <a href="#">AE01</a> <a href="#">Edit</a>	kg/m3	fpagk19
B	29	Assign.Channel 20 = <a href="#">AE01</a> <a href="#">Edit</a>	kg/m3	fpagk20
D	30	GQ trigger	00000000 hex	qbhTrigger
D	31	GQ trig. pattern	00000000 hex	qbhTrgPatt

Enter Cancel Load defaults Refresh

**Figure 69: Free programmable archive****Assignment to the archive:**

4 control totalizers, 8 special measurement values and 6 special totalizers can be stored in Archive 10. Archive group 16, in which the free inputs can be stored, can be hidden in menu **ID DSfG entity recording** with "no" for the retrieval software with coordinate **ID04 AG 16 Visible**.

**Deletion of archives, log books, change buffer, etc.**

In menu **E Mode**, sub-menu **EM Erasing procedures** (Figure 70: *EM Erasing procedures menu*), archives, log books, etc. can be deleted. As a **Super user** (see chapter 2.3 *Access protection for data and settings*) the coordinates **EM10 Clear log**, **EM11 Clear changes**, **EM12 Clear archive** (DSfG archive of the flow computing and registration instance, as well as the DSfG log book), **EM13 Hour/day reset** (DSfG Archive for the highest load), **EM14 Drag indic. reset** (max and min values of all drag pointers, values are set to the current values), **EM15 accuracy test init** (operating point testing) and **EM16 Clear exceptions** are activated.

**EM Erasing procedures**

Access	Line	Designation	Value	Unit	Variable
Y	10	Clear log	No		logbClr
Y	11	Clear changes	No		pchgClr
Y	12	Clear archive	No		aryClr
Y	13	Hour/day reset	No		STReset
Y	14	Drag indic. reset	No		MnMxClr
Q	15	accuracy test init	No	▼	revClr
Y	16	Clear exceptions	No		excClr

Enter Cancel Load defaults Refresh

**Figure 70: EM Erasing procedures menu**

Further details about the archive are provided in the *appendix C) Archive assignment, depth and identification*.

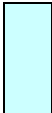


**2.5.7 Alarm, warning message**

Status	No	Time	Text
inactive	W47-1	20.09.2018 12:26:09	Flow rate at measurement conditions e...
inactive	W47-5	20.09.2018 12:26:09	Volumetric flow rate at base condition...
active	A03-1	20.09.2018 14:22:00	Absolute pressure below lower alarm limit
active	W03-4	20.09.2018 14:22:00	Absolute pressure below lower warnin...
active	H07-9	20.09.2018 15:11:18	Inconsistent parameterization, carbon ...
active	M54-0	20.09.2018 10:37:47	Calibration lock is open

**Figure 71: "Messages"**

All messages that have taken place since the last deletion are displayed in different colors in this field:

- Red  Pending alarms, i.e. faults of the custody transfer functions that result in counting in the disturbance totalizers. General alarms are identified with "A"; internal computer errors are identified with "R".
- Yellow  Current warnings, identified with "W", that refer to an error of a non-custody-transfer function. The main totalizers continue to run.

Light blue		Notices ("H") of implausible parameterization or potentially faulty operating statuses. The notices can be converted to warnings and vice versa under coordinate <b>JA07</b> .
Turquoise		Messages ("M") normal operating statuses, e.g. "User lock is open".
Gray		Alarms or warnings that are temporary, have not been acknowledged, but are no longer present.

**LED status:** Warning and alarm messages are displayed by a yellow (warning) and a red (alarm) LED on the front side of the device. The blinking LED indicates an active message. If a continuous light is present, the warning (alarm) is no longer present, but the message has not been deleted yet. **If multiple messages are pending simultaneously, the blinking status has priority.**

**Relay closes** The warning relay and/or alarm relay closes in parallel.

If single-value and double-value messages are differentiated between; a single-value message appears and then is pending permanently, the two-value message is always present, but with interruptions. There is only one status for single-value messages: "Message is active"; the active status for these messages remains in effect until acknowledgment. The warning or alarm relay is energized if a (or multiple) message(s) occurs (occur) and reset if no messages are present. The relays remain active for single-value messages until acknowledgment.

All messages that have not been acknowledged are shown in the display. With "Delete", the no longer pending alarms and warnings and all other messages are deleted from this display. With "Delete", the relevant LEDs are also deleted, if no alarm or warning is pending. However, the deleted messages are stored in the log book (archive group 21). If no events are pending, the following text appears: "no errors".

The "Message" tab is displayed in the color of the error having the highest value if you are in other menus / screens.

Warning and alarm messages can also be acknowledged with a contact input. Assignment takes place with coordinate **JA31 SRC error quit ctc**



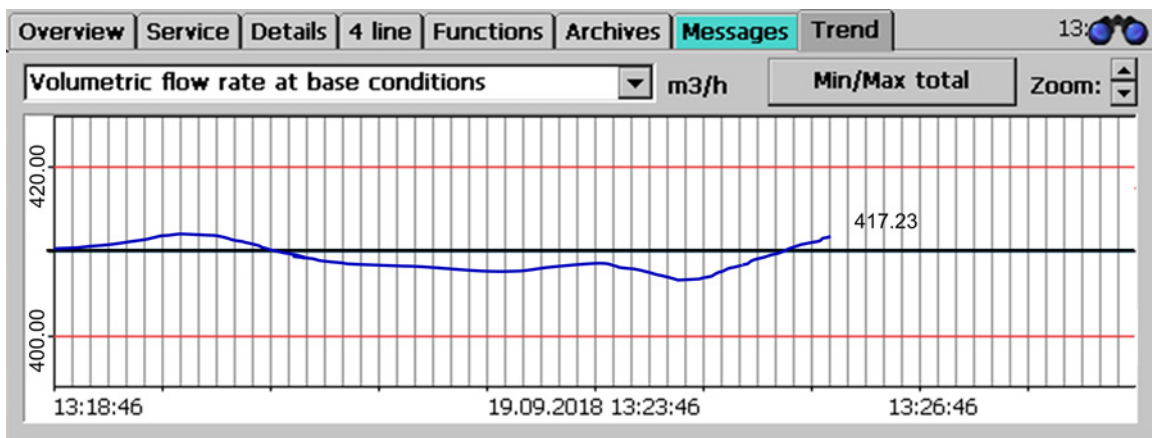
**JA Fault messages**

Access Line	Designation	Value	Unit	Variable
D 1	Current messages	M54-0 Calibr. lock		actErr
D 2	Accumulated msgs	M54-1 User lock		cumErr
D 3	No. of alarms	0		alarmAnz
D 4	No. of warnings	0		warnAnz
D 5	No. of notes	1		hinweisAnz
E * 6	Computer fault	As alarms		rechnerErr
B 7	Notes	As notes		hinweis
Q 8	Fault ackn. flag	0		errorQuit
D 9	Current messages	M54-0 Calibr. lock		actErr_2
...				
D 28	Bits flux control		0000 hex	spoeth
A * 29	Vm-Alarm	0		midVBErr
D 30	Error quit contact		OFF	ktkEquip
B 31	Src error quit ctc	OFF		kzoEquip

Enter Cancel Load defaults Refresh

**Figure 72: Acknowledgment of alarms and warnings**

**2.5.8 Trend**



**Figure 73: "Trend"**

**Overview**

The trend screen offers the option of graphical representation the time curve of a selectable value. For this purpose, a value and/or a position of the list must be selected in the upper part of the screen (Temperature, measured value, Absolute pressure, measured value, standard density, measured value, Density, measured value, Superior calorific value, measured value, Carbon dioxide, normalized molar fraction, Nitrogen, normalized molar fraction, Hydrogen, normalized molar fraction, Volumetric flow rate at base conditions, Energy flow rate, measured value), to which a numerical value and unit are assigned. Assignment takes place in *TA Trend block* based on the coordinate designation (*Figure 74: Menu TA Trend block*).

Value changes over time are displayed after activation of the trend screen. This status is recognizable in that the time displayed runs under the x-axis and the graph moves in the past to the left.

It is possible to view the time curve in front of the displayed time range and to zoom in on the value range:

- The value of the measurement variable can be decreased or increased. The y-axis is scaled automatically for the first representation. A zoom function (top right) can be activated to increase or decrease the display in intervals. The value range of the displayed value is shown.
- The scaling of the time axis is permanently specified.
- By swiping right on the touch screen, the past can be retrieved. This status is recognizable in that the time displayed is stationary under the x-axis and the graph does not move independently.
- The view of the past extends up to one hour.

### TA Trendblock

Access Line	Designation	Value	Unit	Variable
B 1	Recording 1 = <a href="#">AC01</a>	<a href="#">Edit</a>	K	<a href="#">trendbl1</a>
B 2	Recording 2 = <a href="#">AB01</a>	<a href="#">Edit</a>	MPa	<a href="#">trendbl2</a>
B 3	Recording 3 = <a href="#">AE01</a>	<a href="#">Edit</a>	kg/m <sup>3</sup>	<a href="#">trendbl3</a>
B 4	Recording 4 = <a href="#">AG01</a>	<a href="#">Edit</a>	kg/m <sup>3</sup>	<a href="#">trendbl4</a>
B 5	Recording 5 = <a href="#">AD01</a>	<a href="#">Edit</a>	kWh/m <sup>3</sup>	<a href="#">trendbl5</a>
B 6	Recording 6 = <a href="#">BB01</a>	<a href="#">Edit</a>	mole%	<a href="#">trendbl6</a>
B 7	Recording 7 = <a href="#">BD01</a>	<a href="#">Edit</a>	mole%	<a href="#">trendbl7</a>
B 8	Recording 8 = <a href="#">BC01</a>	<a href="#">Edit</a>	mole%	<a href="#">trendbl8</a>
B 9	Recording 9 = <a href="#">HD01</a>	<a href="#">Edit</a>	m <sup>3</sup> /h	<a href="#">trendbl9</a>
B 10	Recording 10 = <a href="#">HB01</a>	<a href="#">Edit</a>	kW	<a href="#">trendbl10</a>
B 11	erase trend	<input type="text" value="No"/>		<a href="#">deltrend</a>

**Figure 74: Menu TA Trend block**

The trends can be recorded in the trend block for various parameters which can be assigned by clicking on [edit](#).

## 2.5.9 Maximum load

The screen display enables the display of various maximum loads via browser. They are found in menu **P Maximum load**. The following displays are provided:

2.5.9.1 PB Maximum load display, maximum hourly value of the day

**PB Maximum load display, maximum hourly value of the day**

Access Line	Designation	Value	Unit	Variable
D 1	Max. hour/day	Maximum load		<a href="#">tagStd_hb</a>
D 10	Uncorr.vol.meas.		0 m3	<a href="#">tagStd_vu</a>
D 11	Time unc.vol.meas.	DD-MM-YYYY hh:mm:ss		<a href="#">ztagStd_vu</a>
A * 12	Vol. at base cond.		0 *100 m3	<a href="#">tagStd_vn</a>
A * 13	Time vol.base	DD-MM-YYYY hh:mm:ss		<a href="#">ztagStd_vn</a>
A * 14	Quantity of energy		0 MWh	<a href="#">tagStd_e</a>
A * 15	Time energy	DD-MM-YYYY hh:mm:ss		<a href="#">ztagStd_e</a>
D 16	Mass		0 *100 kg	<a href="#">tagStd_m</a>
D 17	Time mass	DD-MM-YYYY hh:mm:ss		<a href="#">ztagStd_m</a>
D 18	Corr.vol.meas.		0 m3	<a href="#">tagStd_vk</a>
D 19	Time corr.vol.meas.	DD-MM-YYYY hh:mm:ss		<a href="#">ztagStd_vk</a>

Refresh

**Figure 75: Menu PB Maximum load display, maximum hourly value of the day**

Menu **PB Maximum load display, maximum hourly value of the day** is purely a display menu.

For a simple check, the smallest time unit for the highest load is displayed as one minute. The highest load determination of hour, day and month values takes place on this basis. Without running a separate buffer in time lapse, it is possible to check the highest load with the original data. A test cycle of one hour is reduced to one minute, etc.

The following menus have a similar structure and are not explained further.

- PC Maximum load display of the maximum hourly value of the month**
- PD Maximum load display of the maximum hourly value of the year**
- PE Maximum load display of the maximum daily value of the month**
- PF Maximum load display of the maximum daily value of the year**
- PG Maximum load display of the maximum minute value of the hour**

The residual quantities not included in the preceding menus are displayed in menu **PH Current maximum load quantities**.

## 2.6 Time system

The general displays and parameters are located in menu **KA Times**. All displays and parameters required externally for the time signal are displayed in **KB Clock generator** when the ERZ2000-NG is the source for the time signal. All displays and parameters required for reception of the signal are required in **KC ext. time signal**.

The time system consists of a battery-buffered, quartz-controlled real-time clock module (RTC). This provides the basic time for the ERZ2000-NG.

### 2.6.1 KA Times and time settings

The settings for the time and date specifications take place in menu **KA Times** in coordinate **KA01 Date and time** (Figure 76: Menu KA Times). The user lock must be open for adjustment.

#### KA Times

Access	Line	Designation	Value	Unit	Variable
P	1	Date and time	<a href="#">Edit</a>		<a href="#">now</a>
D	2	UTC	19-09-2018 12:24:23		<a href="#">utc</a>
D	3	Diff. to UTC	7200	s	<a href="#">gmttoff</a>
D	4	Day of the week	Wednesday		<a href="#">WochenTag</a>
D	5	Date and time	19-09-2018 14:24:07		<a href="#">now_2</a>
D	6	Time zone DSfG		S	<a href="#">tzone</a>
D	7	Time zone change	25-03-2018 03:00:00		<a href="#">tzoneChg</a>
D	9	No. Ajax Conn.	1		<a href="#">actAjaxConn</a>
T	13	Time zone	<a href="#">Edit</a>		<a href="#">tzoneinfo</a>
B	14	Billing hour	<input type="text" value="15"/>	h	<a href="#">gasHour</a>
T	15	Time event mode	Local time ▼		<a href="#">timeEvtMode</a>
D	27	Gas day start	18-09-2018 15:00:00		<a href="#">gasDayBeg</a>
D	28	Gas month start	01-09-2018 15:00:00		<a href="#">gasMonBeg</a>
D	29	Gas year start	01-01-2018 15:00:00		<a href="#">gasYeaBeg</a>
D	30	date of local time	19.09.2018		<a href="#">now_Datum</a>
D	31	time of local time	14:24:23		<a href="#">now_Zeit</a>

Enter Cancel Load defaults Refresh

**Figure 76: Menu KA Times**

The entry can be activated with "Edit". When "Edit" is clicked, a menu *Figure 77: Adjustment of date and time* appears to adjust the date and time:

Access Line	Designation	Value	Unit Variable
P	1	Date and time	19-09-2018 14:27:43
			<a href="#">now</a>
Enter		Cancel	Take PC time

**Figure 77: Adjustment of date and time**

The desired date and time can be written directly into the field. The values are checked for plausibility and adopted with "Entries". If necessary, the PC time can be adopted directly (by clicking).

The internal real-time clock (RTC chip) of the ERZ2000-NG is operated with the world time UTC **KA02 UTC**. Consequently, the current location time **KA01 Date and time** is calculated and displayed with the offset according to the adjusted time zone. Like above, a menu is opened by clicking on **KA13 Time zone** in order to select a time zone. All time zones worldwide are available options.

Access Line	Designation	Value	Unit Variable
T	13	Time zone	W. Europe Standard Time
			<a href="#">tzoninfo</a>
Enter		Cancel	

- Ulaanbaatar Standard Time
- US Eastern Standard Time
- US Mountain Standard Time
- UTC
- Venezuela Standard Time
- Vladivostok Standard Time
- W. Australia Standard Time
- W. Central Africa Standard Time
- W. Europe Standard Time**
- West Asia Standard Time
- West Pacific Standard Time
- Yakutsk Standard Time
- UTC+01
- UTC+02
- UTC+03
- UTC+03.50
- UTC+04
- UTC+04.50
- UTC+05
- UTC+05.50
- UTC+05.75
- UTC+06
- UTC+06.50
- UTC+07
- UTC+08
- UTC+09
- UTC+09.50
- UTC+10
- UTC+11
- UTC+12

**Figure 78: Setting the time zone**

The desired time zone can be selected and entered.

Examples:

**UTC+1** means GMT+1 and corresponds to winter time in central Europe

**UTC-1** means GMT-1 and corresponds to the time zone west of Greenwich

With selection possibilities corresponding to UTC±x, no summertime changeover is carried out, such as with "UTC+1". With all other selection options, e.g. "W. Europe

Standard Time", the summertime changeover is activated automatically, on the condition that there is a statutory regulation for the time zone.

**Examples** for time zone adjustment and for deactivation of summertime changeover.

### Germany

- **With** summertime changeover  
**KA13 Time zone** = "W. Europe Standard Time"  
**KA03 Diff. to UTC** = "3600 s"  
 (corresponds to +1 hour; plus an additional 3600 s during summertime)
- **Without** summertime changeover  
**KA13 Time zone** = **UTC+1**  
**KA03 Diff. to UTC** = "3600 s" (corresponds to + 1 hour)

### Israel

- **With** summertime changeover  
**KA13 Time zone** = "Israel Standard Time"  
**KA03 Diff. to UTC** = "7200 s"  
 (2 hours, plus an additional hour during the summertime)
- **Without** summertime changeover  
**KA13 Time zone** = "UTC+2"  
**KA03 Diff. to UTC** = "7200 s" (2 hours)

### Paraguay

- **With** summertime changeover  
**KA13 Time zone** = Paraguay Standard Time  
**KA03 Diff. to UTC** = "-14400 s" (plus one hour during the summertime)
- **Without** summertime changeover  
**KA13 Time zone** = UTC-4  
**KA03 Diff. to UTC** = "-14400 s"

Additional information is available online: [www.weltzeituhr.com](http://www.weltzeituhr.com).

### Procedure for adjusting the time

1. I am in Butzbach and my watch shows the correct local time.
2. The time zone **KA13** of the computer shows "W. European Standard Time".
3. I enter the time in the computer.
4. The computer now shows the correct local time in Germany.
5. The destination country is Afghanistan.
6. I change the time zone **KA13** to "**Afghanistan Standard Time**".
7. The computer now shows the correct local time in Afghanistan.

## 2.6.2 KB Time contact signal to external devices

### KB Time contact signal to external devices

Access Line	Designation	Value	Unit	Variable
D 1	Time contact		0 s	<a href="#">zKtk</a>
B 2	Time cont. duration	<input type="text" value="5"/>	s	<a href="#">zKtkLen</a>
B 3	Time cont. mode	Every minute ▾		<a href="#">zKtkMod</a>
D 10	Modbus year	2018		<a href="#">giaYY</a>
D 11	Modbus month	9		<a href="#">giaMO</a>
D 12	Modbus day	19		<a href="#">giaDD</a>
D 13	Modbus hour	14		<a href="#">giaHH</a>
D 14	Modbus minute	36		<a href="#">giaMI</a>
D 15	Modbus second	26		<a href="#">giaSS</a>
D 20	DSfG time	1537367786	s	<a href="#">DSfGZeit</a>
E * 21	DSfG sync.source	OFF ▾		<a href="#">zDsfgQll</a>
D 30	UTC FC BIOS	19-09-2018 12:36:25		<a href="#">utcFcb</a>

**Figure 79: Menu KB Time contact signal to external devices**

The ERZ2000-NG can issue a time contact pulse in order to synchronize other devices. For this purpose, the length of the pulse can be adjusted in **KB02 Time cont. duration** and the frequency in which the pulse is generated can be adjusted in **KB03 Time cont. mode** ("off", "every minute", "every 30 seconds", "every hour", "every 30 minutes", "every day", "gas day", "every month", "every year", "gas month" and "gas year"). The contact output is also assigned (see *chapter 2.7.7.2 Output characteristics*). The polarity must be adapted if necessary. If **KB21 DSfG sync. source** is "on", the computer generates an attention telegram Z for DSfG time synchronization.

### 2.6.3 KC external time signal

#### KC External time signal

Access Line	Designation	Value	Unit	Variable
T	1	Sync.mode input	OFF	<a href="#">zeitSyncMode</a>
T	2	timesync.tolerance	2	<a href="#">syncZul</a>
E *	3	Time sync. rule	Always	<a href="#">tsetMode</a>
B	4	Retrigger success	90000	<a href="#">ptbOk</a>
B	5	Retrigger fault	300	<a href="#">ptbNok</a>
Q	6	PTB trigger	0	<a href="#">ptbCall</a>
D	7	Clock free wheel	13752	<a href="#">freiLauf</a>
B	10	Phone: PTB	0531512038	<a href="#">ptbNumber</a>
A *	20	Time sync.contact	OFF	<a href="#">ktkSyncClk</a>
E *	21	Source time contact	OFF	<a href="#">kzoSyncClk</a>
I	30	GPS-time (UTC)	01-01-1970 00:00:00	<a href="#">gpsTime</a>
I	31	Time telegram	OFF	<a href="#">gpsStrg</a>
B	40	time server	ptbtime2.ptb.de	<a href="#">timeSrv</a>
B	41	time serv. protocol	UDP	<a href="#">tsrvtyp</a>
B	42	Network interface	ETH2	<a href="#">timeBind</a>
D	50	Reference timediff	-174 s	<a href="#">refzDif</a>
B	51	Reference hour	14	<a href="#">refzHH</a>
B	52	Reference minute	37	<a href="#">refzMI</a>
B	53	Reference second	23	<a href="#">refzSS</a>
M	60	Modb.sync year	0	<a href="#">modwYY</a>
M	61	Modb.sync month	0	<a href="#">modwMO</a>
M	62	Modb.sync day	0	<a href="#">modwDD</a>
M	63	Modb.sync hour	0	<a href="#">modwHH</a>
M	64	Modb.sync minute	0	<a href="#">modwMI</a>
M	65	Modb.sync second	0	<a href="#">modwSS</a>
M	66	Modb.sync trigger	0	<a href="#">modwTimTrig</a>

Enter Cancel Load defaults Refresh

Figure 80: Menu KC external time signal

Coordinate **KC01 Sync mode input** determines the source and interpretation of external time synchronization. The following options are available:

Off	
DSfG	Time synchronization is only expected and accepted via DSfG.
Full minute	The time contact takes place on the whole minute
In second 30	The time contact takes place on the half minute
Full hour	The time contact takes place on the whole minute
In minute 30	The time contact takes place on the whole minute
PTB time service	Time is supplied from PTB
Network timeserv.	Time is supplied from a network



Network SNTP	Time is supplied from SNTP
GPS 170	Time is supplied GPS
To reference time	Time is supplied from a reference
Modbus	Time is supplied from Modbus

The following applies for the time contact options:

- Synchronization takes place on the rising flank.
- Polarity can be changed with *NT04 Inverter mask* of the contact inputs. The computer time is changed on the next whole/half minute or whole/half hour, depending on the setting.

Any time synchronization via DSfG is ignored in these cases.

The **KC03 Time sync. rule** defines criteria for whether the time of the converter can be adjusted via external timers (e.g. DSfG radio clock, external contact).

<b>Always</b>	The clock is always set.
<b>PTB Criterion (strict)</b>	Automatic adjustment of the time – with closed calibration switch – can take place with the adjustment is within a time window of +/- 20 seconds, but no more than once per day. When the calibration switch is open, any arbitrary entries are possible.
<b>PTB Crit. light</b>	Automatic adjustment of the time takes place according to the strict PTB criterion, but, additionally if: <ul style="list-style-type: none"> <li>• User access (password) is open.</li> <li>• After a restart of the computer and the first synchronization has not taken place yet.</li> <li>• The clock has been incorrect for more than 59 minutes and 40 seconds. (e.g. adapted summertime/wintertime changeover)</li> <li>• After manual time adjustment and the subsequent synchronization has not taken place yet.</li> <li>• e.g. to test if automatic synchronization works by consciously adjusting the clock incorrectly.</li> </ul>

The clock module can be synchronized with a superordinate timer via coordinate **KC21 Source time contact** (external synchronization input). Depending on the access authorization, the internal time basis can be changed with the keyboard or DSfG interface.

### PTB Time service

If telephone access with MODEM is available, ERZ2000-NG can use the **PTB Time service** with its integrated DFÜ and thus synchronize its clock (and the clocks of all bus participants). The following setting is made in menu **KC Externl time signal**:

96

<b>KC01 Sync.mode Input</b>	"PTB Time service"
<b>KC10 Phone: PTB</b>	<b>0531512038</b> Telephone number of the PTB; depending on the internal telephone network, it may be necessary to add an <b>additional leading "0"</b> (without blank space)
<b>KC06 PTB trigger</b>	The remaining time in seconds until the ERZ2000-NG calls the number specified above automatically is indicated here.
<b>KC05 Retrigger fault</b>	The time that the device waits before calling again if, for example, the number is busy

#### Example:

Trigger by hand: Overwriting of the displayed remaining time with entry of the number 2 means a call takes place after 2 seconds. If the call was successful and a plausible time was "heard", the value in KC06 is set to 90,000 seconds, i.e. the next call attempt takes place in 25 hours. If the number was busy or the time was not plausible, the value in KC05 (e.g. 300 seconds) applies and the ERZ2000-NG counts down to 0 and then attempts to call again.

The time is synchronized once per day in the PTB-compliant operating mode PTB criterion. With coordinate "KC03 Time sync. rule" there are 3 operating modes for this purpose:

PTB criterion	The synchronization window is +/-20 seconds
PTB criterion soft	+/-20 seconds, like above, plus correction of an adjusted summertime changeover
Always	Each time sync telegram is evaluated and adopted

#### Note

**With PTB criterion and PTB criterion soft, the synchronization window is +/- 20 seconds.**

**With greater deviations, the clock is no longer synchronized!!**

**This applies for synchronization via the synchronization input and the synchronization telegram (DSfG bus).**

There is an additional option to connect GPS reception modules of any manufacturer to the COM 5 (modem) interface. The ERZ2000-NG recognizes the following protocols:

- NMEA 0183
- Meinberg standard
- SAT standard
- Uni Erlangen
- ABB SPA
- Computime and RACAL.

97

A reference time can also be synchronized. This can be parameterized with coordinates **KC51 Reference hour**, **KC52 Reference minute** and **KC53 Reference second**. The process is triggered via a contact input which can be selected with coordinate **KC 21 Source time contact**.

#### Timeserver network

If a time server is known, synchronization can take place via the network.

The following must be observed:

The IP address of the time server must be entered in coordinate **KC40 Time server 37/123**, e.g. 192.53.103.104, corresponding to the internet address ptbtime2.ptb.de of the PTB time server. The IP address can be determined by pinging ptbtime2.ptb.de. The protocol of the time server is adjusted in **KC41 Time serv. protocol**, e.g. connection type "UDP" of the PTB time server or "TCP".

The IP address of the local gateway, e.g. 192.168.20.254 of the standard gateway of RMG Beindersheim can be determined with ipconfig. If an internet address is entered in **KC40 server Port 37/123**, a domain name service must be activated in order to implement a conversion to an IP address. Please select Ethernet connection 1 or 2 in coordinate **KC42 Network interface**, depending on your choice (see *chapter 2.7.4 Data interfaces*).

The IP addresses for the Domain Name Service, i.e. DNS of the telecom are found in menu **IA TCP/IP network**.

#### Note

**After a change of network settings, the network of the ERZ2000-NG must be switched off and on again for the settings to take effect.**

**GPS170**

Synchronization takes place with a GPS reception module on COM 5. The following protocols are supported:

Meinberg Std., NMEA, Computime, ABB SPA, Uni Erlangen, SAT, Racal.

**2.6.4 KD Plausibility****KD Plausibility controls of time**

Access	Line	Designation	Value	Unit	Variable
D	1	Seconds since start	16136	s	<a href="#">rtcSeks</a>
D	3	Base timer	16143.0114	s	<a href="#">baseCpuDif</a>
D	7	Time check	7.0114	s	<a href="#">timCheck</a>
D	8	Skipped seconds	5	s	<a href="#">secJump</a>
D	9	Time fraction	16177	s	<a href="#">timZwk</a>
D	10	Time counter	.985915	s	<a href="#">timRest</a>

Refresh

**Figure 81: Menu KD Plausibility**

The ERZ2000 has 2 clocks - a long-term clock (hh:mi:ss /hours:minutes:seconds/ DD:MO:YY / day:month:year/) and a short-term clock that can be calibrated. The short-term clock is used for totalizer integration for effective pressure computers, calibration on the fly and operating point testing and frequency measurement.

Both clocks have individual clock drift. Over a period of 1.2 million seconds (**KD01**), the long-term clock runs 85 seconds (**KD07**) faster than the short-term clock.

## 2.7 Electrical connections

### 2.7.1 Equipment variants

The assignment of the connection terminals of the ERZ2000-NG is essentially specified by the compact configuration. However, there are reserves, because a different definition of the terminal assignment is necessary depending on additionally installed extension modules. The positions of the extension boards and assignments for the plug strips are specified in the additional data sheet for the device. The unoccupied slots can be optionally equipped with the following extension boards:

- |  |   |
|--|---|
| 1. <b>DSfG board</b>                       | for flow corrector and registration instance and DSfG control station     |
| 2. <b>Ex isolation board</b>               | for volume (measurement and comparison), Vc, p and T with 4..20mA or HART |
| 3. <b>HART board</b>                       | for 3 transmitters or as a double circuit board with up to 6 transmitters |
| 4. <b>Frequency measurement board 5..8</b> | for density transmitters with a density conversion                        |

The modules that are used are recognized automatically by the ERZ2000-NG. The menu **EH Module assembly** shows the modules recognized by the system and inserted. Therefore, the menu is provided as information for automatic recognition or troubleshooting. This information is important for the assembly of device combinations in the factory or for equipping modules at a later time.

### EH Module assembly

Access	Line	Designation	Value	Unit	Variable
S	1	Mod. 1A should be	COM3+4-card		<a href="#">m1ASoll</a>
I	2	Mod. 1A assembly	Passive		<a href="#">m1ASteck</a>
I	3	Mod. 1A Id	0		<a href="#">m1AKenn</a>
I	4	Mod. 1A version	0.00		<a href="#">m1AVer</a>
I	5	Mod. 1A status 1	0000	hex	<a href="#">m1ASt1</a>
I	6	Mod. 1A status 2	0000	hex	<a href="#">m1ASt2</a>
I	7	Mod. 1A status 3	0000	hex	<a href="#">m1ASt3</a>
I	8	Mod. 1A status 4	0000	hex	<a href="#">m1ASt4</a>
S	11	Mod. 1B should be	Unknown		<a href="#">m1BSoll</a>
I	12	Mod. 1B assembly	Unknown		<a href="#">m1BSteck</a>
I	13	Mod. 1B Id	0		<a href="#">m1BKenn</a>
I	14	Mod. 1B version	0.00		<a href="#">m1BVer</a>
I	15	Mod. 1B status 1	0000	hex	<a href="#">m1BSt1</a>
I	16	Mod. 1B status 2	0000	hex	<a href="#">m1BSt2</a>
I	17	Mod. 1B status 3	0000	hex	<a href="#">m1BSt3</a>
I	18	Mod. 1B status 4	0000	hex	<a href="#">m1BSt4</a>
S	21	Mod. 2A should be	Unknown		<a href="#">m2ASoll</a>
I	22	Mod. 2A assembly	Unknown		<a href="#">m2ASteck</a>
I	23	Mod. 2A Id	0		<a href="#">m2AKenn</a>
I	24	Mod. 2A version	0.00		<a href="#">m2AVer</a>
I	25	Mod. 2A status 1	0000	hex	<a href="#">m2ASt1</a>
I	26	Mod. 2A status 2	0000	hex	<a href="#">m2ASt2</a>
I	27	Mod. 2A status 3	0000	hex	<a href="#">m2ASt3</a>
I	28	Mod. 2A status 4	0000	hex	<a href="#">m2ASt4</a>
S	31	Mod. 2B should be	Unknown		<a href="#">m2BSoll</a>
I	32	Mod. 2B assembly	Unknown		<a href="#">m2BSteck</a>
I	33	Mod. 2B Id	0		<a href="#">m2BKenn</a>
I	34	Mod. 2B version	0.00		<a href="#">m2BVer</a>
I	35	Mod. 2B status 1	0000	hex	<a href="#">m2BSt1</a>
I	36	Mod. 2B status 2	0000	hex	<a href="#">m2BSt2</a>
I	37	Mod. 2B status 3	0000	hex	<a href="#">m2BSt3</a>
I	38	Mod. 2B status 4	0000	hex	<a href="#">m2BSt4</a>
S	41	Mod. 3A should be	Exi-card		<a href="#">m3ASoll</a>
I	42	Mod. 3A assembly	Active		<a href="#">m3ASteck</a>
I	43	Mod. 3A Id	300		<a href="#">m3AKenn</a>
I	44	Mod. 3A version	1.10		<a href="#">m3AVer</a>
I	45	Mod. 3A status 1	0000	hex	<a href="#">m3ASt1</a>
I	46	Mod. 3A status 2	0000	hex	<a href="#">m3ASt2</a>
I	47	Mod. 3A status 3	0031	hex	<a href="#">m3ASt3</a>
I	48	Mod. 3A status 4	0297	hex	<a href="#">m3ASt4</a>
I	49	Namur status M3A	0004	hex	<a href="#">namst1</a>
S	51	Mod. 3B should be	Unknown		<a href="#">m3BSoll</a>
I	52	Mod. 3B assembly	Unknown		<a href="#">m3BSteck</a>
I	53	Mod. 3B Id	0		<a href="#">m3BKenn</a>
I	54	Mod. 3B version	0.00		<a href="#">m3BVer</a>
I	55	Mod. 3B status 1	0000	hex	<a href="#">m3BSt1</a>
I	56	Mod. 3B status 2	0000	hex	<a href="#">m3BSt2</a>
I	57	Mod. 3B status 3	0000	hex	<a href="#">m3BSt3</a>
I	58	Mod. 3B status 4	0000	hex	<a href="#">m3BSt4</a>
I	59	Namur-status M3B	0000	hex	<a href="#">namst2</a>

Refresh

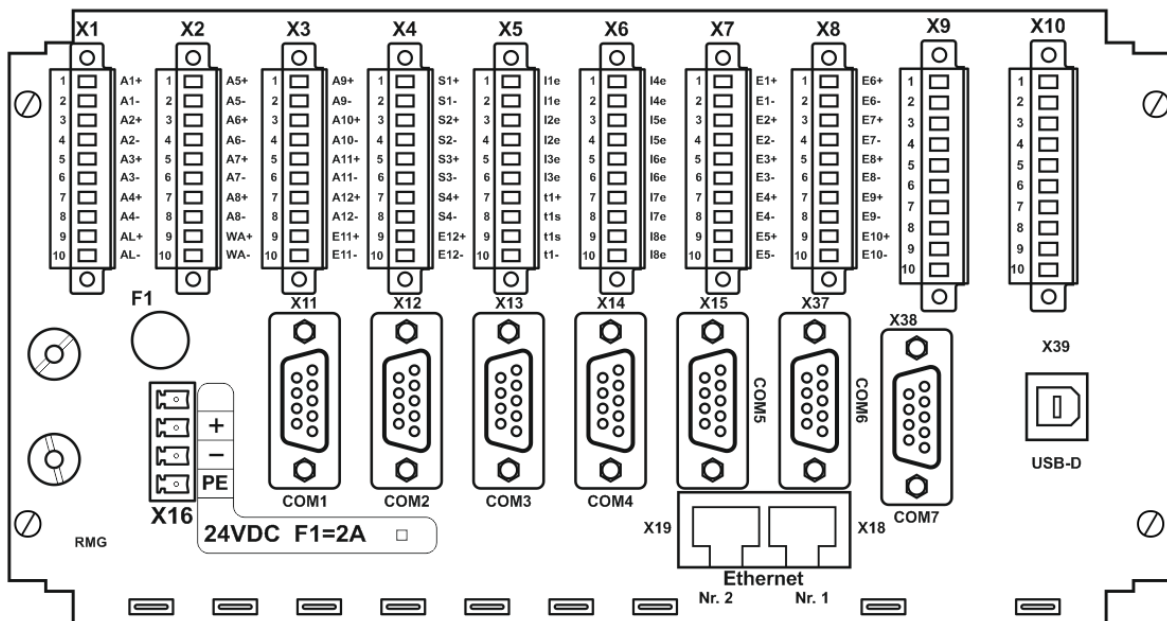
**Figure 82: Menu EH Module assembly**

**Note**

"COM 6 + 7" is not displayed in coordinate EH Module equipment.

**Device rear wall**

Since the ERZ2000-NG has a universal configuration, there are more connection terminals that required by the typical device (e.g. a status flow computer). There is a standard assignment of terminals that always use the first pins in consideration of numbering. Additional pins are reserves and/or can be assigned by means of software. Therefore, it is also possible to connect the pressure transducer to one of the free reserve inputs and select it by means of software.



**Figure 83: Rear wall of the ERZ2000-NG**

**2.7.2 Configuration of connections**

Some basic settings must be configured prior to commissioning and parameterization. They are located in **Menu EI Configuration**.

### EI Configuration

Access	Line	Designation	Value	Unit	Variable
S	1	No.resist.meas.ch.	0		<a href="#">rAnzahl</a>
S	2	No.nonex currents	3		<a href="#">iAnzahl</a>
S	3	No. freq. meas.	4		<a href="#">fAnzahl</a>
B	4	No. of cur.outputs	<input type="text" value="4"/>		<a href="#">iOutAnz</a>
B	5	No. cont.outp.	<input type="text" value="8"/>		<a href="#">kOutAnz</a>
B	6	No. pulse outputs	<input type="text" value="4"/>		<a href="#">pOutAnz</a>
B	7	No. of frq.outputs	<input type="text" value="1"/>		<a href="#">fOutAnz</a>
S	8	FPGA quartz freq.	31999564	Hz	<a href="#">fpgaQuarz</a>
W *	9	Quartz meas. CPU	<input type="text" value="29491200"/>	Hz	<a href="#">cpuQuarz</a>
S	10	L calib.pt. current	4.0000	mA	<a href="#">iukal</a>
S	11	U calib.pt. current	20.0000	mA	<a href="#">iokal</a>
S	12	L calib.pt. ohm(T)	-10.0000	°C	<a href="#">tukal</a>
S	13	U calib.pt. ohm(T)	60.0000	°C	<a href="#">tokal</a>
B	14	Gradient active	<input type="text" value="No"/>		<a href="#">grdWatch</a>
B	15	Meas.warn.lim.act.	<input type="text" value="Yes"/>		<a href="#">wqwWatch</a>
B	16	Drag indic. active	<input type="text" value="Yes"/>		<a href="#">shzWatch</a>
B	17	Means active	<input type="text" value="No"/>		<a href="#">miwWatch</a>
B	18	Show base values	<input type="text" value="No"/>		<a href="#">orgWatch</a>
B	19	Flow warn.lim.act.	<input type="text" value="Yes"/>		<a href="#">wqwfWatch</a>
B	20	Comp.warn.lim.act.	<input type="text" value="Yes"/>		<a href="#">wqkWatch</a>
B	21	Cur. outputs check	<input type="text" value="No"/>		<a href="#">SaCtrl</a>
W *	22	ADC ref. voltage	<input type="text" value="2500.00"/>	mV	<a href="#">adcVref</a>
W *	23	Rref cur.measuram.	<input type="text" value="43.00"/>	Ohm	<a href="#">I_Ref</a>
W *	24	Rref PT100 meas.	<input type="text" value="274.00"/>	Ohm	<a href="#">PT100_Ref</a>
W *	25	Rref PT1000 meas.	<input type="text" value="3000.00"/>	Ohm	<a href="#">PT1000_Ref</a>
W *	26	Rref KTY measuram.	<input type="text" value="3240.00"/>	Ohm	<a href="#">KTY_Ref</a>
B	27	Drag indicator mode	<input type="text" value="Base value"/>		<a href="#">mnmxMod</a>
B	28	Analyt. assessment	<input type="text" value="No"/>		<a href="#">apxWatch</a>
S	29	Vol.freq. source	f1/f2		<a href="#">pulsQll</a>
B	30	VOS deviat. ctrl.	<input type="text" value="No"/>		<a href="#">vsbCtrl</a>
S	31	No.resist.meas.exi	1		<a href="#">rxAnzahl</a>
S	32	No. exi currents	2		<a href="#">ixAnzahl</a>
S	33	Freq.1/5-source	F1-X8 / F5-X9		<a href="#">muxhf1</a>
S	34	Freq.2/6-source	F2-X8 / F6-X9		<a href="#">muxhf2</a>
S	35	Freq.3/7-source	F3-X8 / F7-X9		<a href="#">muxhf3</a>
S	36	Freq.4/8-source	F4-X8 / F8-X9		<a href="#">muxhf4</a>
S	37	ENCO-source	Term. X9-1,X9-2		<a href="#">encosrc</a>
B	38	Dead man button	<input type="text" value="10"/>	s	<a href="#">wdogSek</a>
B	39	Boot delay	<input type="text" value="8"/>	s	<a href="#">bootdelay</a>

Figure 84: Menu EI Configuration



The number of inputs and outputs to be connected is entered in coordinates **EI01** to **EI07**. The ERZ2000-NG only enables and activates according to what is specified here. **EI08** and **EI09** contain the factory settings of the quartz frequency, which should not be changed.

It is important for the calculation of current linearities to enter the actual lower and upper values for the reference sources in coordinates **EI10** to **EI13**.

103

With coordinates **EI14** to **EI20**, the specified functions and warnings can be activated. **EI14** activates the supervision of gradient for all measured values. For example, to find out if the pressure increases or decrease faster than expected. **EI17** activates the calculation of average values (minute, hour, day, month). **EI18** displays a measured value before it is controlled by alarm limits and probably replaced by default value.

Coordinates **EI22** to **EI26** contain reference values for temperature measurement; they must not be changed.

In **EI27 Drag indicator mode**, the drag pointer must be set to the source value (for conversion of measurement) or base value (original measurement). Generally, **EI28 Analyt. assessment** is deactivated. **EI28 AGA8 (1985)** describes a method to approximate a complete gas composition (mol-% of methane, ethane, ... hexane) out of gross values (calorific value, standard density, carbon dioxide, nitrogen, hydrogen). The method works astonishingly well but isn't in use generally. The source to be used must adjusted in **EI29 Vol.freq. source**; selection: "off", "f1/f2" or "f3/f4". There is more information about **EI30** in *chapter 6.4.2 DB Calculation according to AGA10/Helmholtz ISO20765-1:2005*. You may activate here a comparison between calculated speed of sound and measured speed of sound (e.g. from a ultrasonic meter).

The required number must be adjusted in **EI31** and **EI32**.

Coordinates **EI33** (**EI34**, **EI35** and **EI36**) assign sources (on the Ex board) to the frequency inputs 1 and 5 (2 and 6, 3 and 7 and 4 and 8). **EI37** defines the input for the encoder totalizer on the Ex board.

### 2.7.3 Terminal assignment

**Connection of supply voltage:** *Figure 83: Rear wall of the ERZ2000-NG (bottom left)*

<b>X 16</b>	24 V DC -10% / +15%	Fuse F1 = 2 A	1.0 A Typical power consumption (depending on equipment)	24 W Max. output
-------------	------------------------	---------------	---	---------------------

#### ERZ2000-NG without external Ex- separator stage Ex1-NAMUR-2 / V1 or V2

<b>X 1</b>	Terminal	1	Transistor output 1 +
	Terminal	2	Transistor output 1 -
	Terminal	3	Transistor output 2 +
	Terminal	4	Transistor output 2 -
	Terminal	5	Transistor output 3 +
	Terminal	6	Transistor output 3 -
	Terminal	7	Transistor output 4 +
	Terminal	8	Transistor output 4 -
	Terminal	9	Alarm contact + semiconductor rel. poled, NC
	Terminal	10	Alarm contact – semiconductor rel. poled, NC
<b>X 2</b>	Terminal	1	Transistor output 5 +
	Terminal	2	Transistor output 5 -
	Terminal	3	Transistor output 6 +
	Terminal	4	Transistor output 6 -
	Terminal	5	Transistor output 7 +
	Terminal	6	Transistor output 7 -
	Terminal	7	Frequency output + (higher prio) or transistor output 8 +
	Terminal	8	Frequency output - (higher prio) or transistor output 8 -
	Terminal	9	Transistor output Warning message +
Terminal	10	Transistor output Warning message -	
<b>X 3</b>	Terminal	1	Pulse output 1 + Dispatcher or counter pulse
	Terminal	2	Pulse output 1 - Dispatcher or counter pulse
	Terminal	3	Pulse output 2 + Dispatcher or counter pulse
	Terminal	4	Pulse output 2 - Dispatcher or counter pulse
	Terminal	5	Pulse output 3 + Dispatcher or counter pulse
	Terminal	6	Pulse output 3 - Dispatcher or counter pulse
	Terminal	7	Pulse output 4 + Dispatcher or counter pulse
	Terminal	8	Pulse output 4 - Dispatcher or counter pulse
	Terminal	9	<b>Reserve</b> 2nd input for Vo with external separator stage +
	Terminal	10	<b>Reserve</b> 2nd input for Vo with external separator stage -

<b>X 4</b>	Terminal	1	Current output 1 +
	Terminal	2	Current output 1 -
	Terminal	3	Current output 2 +
	Terminal	4	Current output 2 -
	Terminal	5	Current output 3 +
	Terminal	6	Current output 3 -
	Terminal	7	Current output 4 +
	Terminal	8	Current output 4 -
	Terminal	9	Input for Vo with external separator stage +
	Terminal	10	Input for Vo with external separator stage -

<b>X 5</b>	Terminal	1	Curr. input1, active or passive, pol. see connection examples
	Terminal	2	Curr. input 1, active or passive, pol. see connection examples
	Terminal	3	Curr. input 2, active or passive, pol. see connection examples
	Terminal	4	Curr. input 2, active or passive, pol. see connection examples
	Terminal	5	Curr. input 3, active or passive, pol. see connection examples
	Terminal	6	Curr. input 3, active or passive, pol. see connection examples
	Terminal	7	PT 100/500/1000 # 1 supply ++ standard connection
	Terminal	8	PT 100/500/1000 # 1 sense + standard connection
	Terminal	9	PT 100/500/1000 # 1 sense - standard connection
	Terminal	10	PT 100/500/1000 # 1 supply - - standard connection

<b>X 6</b>	Terminal	1	Curr.input 4, active or passive, pol. (see connection examples)
	Terminal	2	Curr.input 4, active or passive, pol. (see connection examples)
	Terminal	3	Curr.input 5, active or passive, pol. (see connection examples)
	Terminal	4	Curr.input 5, active or passive, pol. (see connection examples)
	Terminal	5	Curr.input 6, active or passive, pol. (see connection examples)
	Terminal	6	Curr.input 6, active or passive, pol. (see connection examples)
	Terminal	7	Curr.input 7, pol. opposite 1-6, or reserve PT 100*
	Terminal	8	Curr.input 7, pol. opposite 1-6, or reserve PT 100*
	Terminal	9	Curr.input 8, pol. opposite 1-6, or reserve PT 100*
	Terminal	10	Curr.input 8, pol. opposite 1-6, or reserve PT 100*

**Note**

**\* X6: Whether the terminals are reserve PT 100 or current input 7 and 8 can be determined by the hardware coding (jumper).**

**Factory setting: Current input 7 and 8.**

<b>X 7</b>	Terminal	1	Signal input 1 + , assignment takes place with software
	Terminal	2	Signal input 1 - , assignment takes place with software
	Terminal	3	Signal input 2 + , assignment takes place with software
	Terminal	4	Signal input 2 - , assignment takes place with software
	Terminal	5	Signal input 3 + , assignment takes place with software
	Terminal	6	Signal input 3 - , assignment takes place with software
	Terminal	7	Signal input 4 + , assignment takes place with software
	Terminal	8	Signal input 4 - , assignment takes place with software
	Terminal	9	Signal input 5 + , assignment takes place with software
	Terminal	10	Signal input 5 - , assignment takes place with software

<b>X 8</b>	Terminal	1	Signal input 6 + , assignment takes place with software
	Terminal	2	Signal input 6 - assignment takes place with software
	Terminal	3	Signal input 7 + reserve for 2nd volume input meas. channel
	Terminal	4	Signal input 7 - reserve for 2nd volume input meas. channel
	Terminal	5	Signal input 8 + reserve for 2nd volume input comp. channel
	Terminal	6	Signal input 8 - reserve for 2nd volume input comp. channel
	Terminal	7	Volume input measuring channel (HFX) + (external isolation)
	Terminal	8	Volume input measuring channel (HFX) - (external isolation)
	Terminal	9	Volume input comparison channel (HFY) + (external isolation)
	Terminal	10	Volume input comparison channel (HFY) - (external isolation)

### Density flow computer ERZ2002-NG / ERZ2012-NG with frequency measurement board F 58; X 9 is assigned

<b>X 9</b>	Terminal	1	Frequency 5 + (density assigned by software)
	Terminal	2	Frequency 5 - (density assigned by software)
	Terminal	3	Frequency 6 + (standard density assigned by software)
	Terminal	4	Frequency 6 - (standard density assigned by software)
	Terminal	5	Frequency 7 + (standard density assigned by software)
	Terminal	6	Frequency 7 - (standard density assigned by software)
	Terminal	7	Frequency 8 + (VOS assigned by software)
	Terminal	8	Frequency 8 - (VOS assigned by software)
	Terminal	9	reserve / free
	Terminal	10	reserve / free

### ERZ2004/2104-NG without frequency measurement board, X9 and X10 remain open

**With internal Ex- separator stage Ex1-NAMUR-2 / V1 or V2:  
(TÜV 06 ATEX 553139 X)**

**ERZ2002/2102-NG; terminal X 8 is assigned for frequency measurement:**

<b>X 8</b>	Terminal	1	Signal input 6 + assignment takes place with software
	Terminal	2	Signal input 6 - assignment takes place with software
	Terminal	3	Signal input 7 + frequency input 5 density by software
	Terminal	4	Signal input 7 - frequency input 5 density by software
	Terminal	5	Signal input 8 + frequency input 6 standard density by software
	Terminal	6	Signal input 8 - frequency input 6 standard density by software
	Terminal	7	Signal input 9 + frequency input 7 standard density by software
	Terminal	8	Signal input 9 - frequency input 7 standard density by software
	Terminal	9	Signal input 10 + frequency input 8 VOS by software
	Terminal	10	Signal input 10 + frequency input 8 VOS by software

107

**ERZ2004/2104-NG; X 9 and X 10 are optionally assigned**

<b>X 9</b>	Terminal	1	Ex-option enco + (Vo)
	Terminal	2	Ex-option enco - (Vo)
	Terminal	3	Ex-option Vb measuring channel (HFX) +
	Terminal	4	Ex-option Vb measuring channel (HFX) -
	Terminal	5	Ex-option Vb comparison channel (HFY) +
	Terminal	6	Ex-option Vb comparison channel (HFX) -
	Terminal	7	Ex-option pressure measurement - transmitter (optional HART)
	Terminal	8	Ex-option pressure measurement + transmitter (optional HART)
	Terminal	9	Ex-option temp. - transmitter (opt. HART) for PT 100 s. X 10
	Terminal	10	Ex-option temp. + transmitter (opt. HART) for PT 100 s. X 10

<b>X 10</b>	Terminal	1	Reserve / free (Ex option for 2-rail version)
	Terminal	2	Reserve / free (Ex option for 2-rail version)
	Terminal	3	Reserve / free (Ex option for 2-rail version)
	Terminal	4	Reserve / free (Ex option for 2-rail version)
	Terminal	5	Reserve / free (Ex option for 2-rail version)
	Terminal	6	Reserve / free (Ex option for 2-rail version)
	Terminal	7	Ex-option PT 100 supply ++
	Terminal	8	Ex-option PT 100 sense +
	Terminal	9	Ex-option PT 100 sense -
	Terminal	10	Ex-option PT 100 supply - -

**Note**

**With use of the internal Ex isolation stage:**

**A mixture of inputs is possible with respect to Ex protection, which means an individual signal can also be used with an external isolation stage or with a pressure-proof encapsulated ignition protection type, in combination with Ex intrinsically safe protection type.**

108

**Example:**

The volume inputs for measuring and comparison channels and the original ENCO counter are operated on **X 9** via the internal Ex board, the pressure transducer is operated as a 4..20 mA transmitter and the temperature probe is operated as PT 100 4-wire connection with pressure-proof encapsulation ignition pressure type and connected to **X 5**.

Other possible mixtures are feasible.

The number of connection possibilities increases if the optional Ex input board is used. This input board enables galvanic isolation of MSR signals, such as 20 mA current loops or the adjustment and/or standardization of signals. Intrinsically safe field devices can be operated within explosion-prone areas with the isolation.

**For further information, refer to appendix F) Optional Ex input board.**

## 2.7.4 Data interfaces

The **digital data interfaces** are also provided on the basic assembly. These interfaces can be used as:

- Service interface
- DSfG, according to the specifications of the flow computer and registration instance
- DSfG control station
- Modbus for external data transmission
- Ethernet TCP/IP network connections
- Connection for an external modem
- Serial data interfaces

The central DSfG bus access for all instances in the device is the RS 485 interface COM 4 (*chapter 2.7 Electrical connections*). If there are multiple instances, each entity can have a dedicated bus address, but there is only one physical bus access. An

exception is the control station, which occupies the COM 3 interface. The visualization and operation are carried out for all functional modules collectively.

**Interface characteristics**

			Recommendation / possible use
X 11	COM 1	Interface	USMs, 1 <sup>st</sup> Modbus RTU, ASCII
X 12	COM 2	Interface	Older USMs, DZU
X 13	COM 3	Interface	DSfG control station, 2 <sup>nd</sup> Modbus
X 14	COM 4	Interface	DSfG or RMG bus
X 15	COM 5	Interface	External modem
X 37	COM 6	Interface	Modbus master for reading the gas composition and volume (F-instance)
X 38	COM 7	Interface	
X 18	Ethernet 1	Network connection	Multi-session capability: Modbus IP, http Single-session (optional interface): Remote operation, DSfG-B-IP, SNTP, TIME
X 19	Ethernet 2	Network connection	

**Note**

The connection of ultrasonic flowmeters to the interfaces COM 1 or COM 2 is possible, but preferred these devices should be connected to the interfaces COM 6 or COM 7.

The connection to COM 1/2 is realized via DZU; as these interfaces do not have a terminating resistor, the connection via an adapter is necessary.

The newer connection variant is realized via instance F at COM 6/7. To address these interfaces at the built-in interface card this card already contains these resistors; no additional adapter may be installed here.

## 2.7.5 Pin assignment and recommended use of the interfaces

### COM 1

#### Pin assignment

Pin	Mode: RS 232	Mode: RS 422	Mode: RS 485
1	+U (+5V DC)	+U (+5V DC)	+U (+5V DC)
2	RxD	TxD-A	
3	TxD		R/TA A Data
4		RxD-A	
5	GND	GND	SGND Signal Ground
6		TxD-B	
7			
8		RxD-B	R/TN B Data
9			

#### Use

Switchable from **RS 232** to **RS 422** or **RS 485**, can be optionally assigned with **different protocols, MODBUS protocol** and **IGM** (for ultrasonic meters) available. Optionally, **MODBUS ASCII / RTU** can be offered as **Modbus standard** driver for RS 232 or RS 485 interfaces.

The operating mode for the COM 1 interface is adjusted in the menu **IB Serial interfaces** with coordinate **IB03 COM 1 operating mode**.



**IB Serial interfaces**

Access Line	Designation	Value	Unit	Variable
B	1	Baud rate COM1	38400	baudC0
B	2	B/P/S COM1	8N1	bpsC0
B	3	COM1 operating mode	OFF	modeC0
B	4	Baud rate COM2	115200	baudC1
B	5	B/P/S COM2	7E1	bpsC1
B	6	COM2 operating mode	Test	modeC1
B	7	Baud rate COM3	19200	baudC3
B	8	B/P/S COM3	7E1	bpsC3
B	9	COM3 operating mode	OFF	modeC3
B	10	Baud rate COM4	9600	baudC4
B	11	B/P/S COM4	8E1	bpsC4
B	12	COM4 operating mode	OFF	modeC4
B	13	Baud rate Vo	2400	baudVO
B	14	B/P/S Vo	7E1	bpsVO
B	15	Vo operating mode	Vo	modeVO
T	16	Timeout gas quality	60	min qbhToMx
B	17	Register offset	0	regOffs
B	18	Modbus address	1	mbAdr
B	19	Baud rate COM5	38400	baudC5
B	20	B/P/S COM5	8N1	bpsC5
B	21	COM5 operating mode	Modem	modeC5
B	22	Modbusaddr. COM1	1	mbAdrC0
B	23	Modbusaddr. COM2	2	mbAdrC1

**Figure 85: IB Serial interfaces**

The operating mode for the COM 1 interface is adjusted in the menu **IB Serial interfaces** with coordinate **IB03 COM 1 operating mode**. The mode can be set to:

- Off
- Test (only internal)
- Modbus RTU
- Modbus ASCII
- IGM
- USE09
- DZU
- FLOWSIC600

**Note**

If a FLOWSIC600 ultrasonic meter is connected, the operating mode of COM 1 must be adjusted to FLOWSIC600 and coordinate "IB25 FLOWSIC address" must be set to the Modbus address of the FLOWSICK ultrasonic meter.

112

**COM 2****Pin assignment**

Pin	Mode RS 232
1	
2	RxD
3	TxD
4	
5	GND
6	
7	
8	
9	

**Use**

**The RS 232 cannot be switched with the DZU protocol occupied!**  
(Connection to US 9000 = main totalizer for ultrasonic gas meter).

The operating mode for the COM 2 interface is adjusted in the menu **IB Serial interfaces** (see above) with coordinate **IB06 COM 2 operating mode**. The following adjustments are possible:

- Off
- Test
- Modbus RTU
- Modbus ASCII
- DZU
- GPS 170

**COM 3**

**Pin assignment**

Pin	Mode: DSFG		Mode RS 232
1	+U (+5V DC)	Power supply	
2	GND	Reference potential (GND)	RxD
3	R/TA	A Data	TxD
4		unassigned	DTR
5	SGND	GND	GND
6	-U	GND	
7	GND	GND	RTS
8	R/TN	B Data	CTS
9		unassigned	

**Use**

Switchable from **RS 232** with handshake to **RS 485 DSfG-compliant**. Can be assigned with a second **Modbus protocol** or the DSfG control station.

**Note**

The DSfG interface implemented in the ERZ2000-NG conforms to the current version of the technical specifications of the DSfG for flow computers.

The DSfG is required in the scope of this documentation (further documentation is available from the DVGW).

The same parameter settings as with COM 1 can be made for a second Modbus interface:

- Off
- Test
- DSfG control station
- Modbus RTU
- Modbus ASCII

**COM 4****Pin assignment**

Pin	Mode: DSFG		Mode: RS 232
1	+U (+5V DC)	Power supply	
2	GND	Reference potential (GND)	RxD
3	R/TA	A Data	TxD
4		unassigned	
5	SGND	GND	GND
6	-U	GND	
7	GND	GND	
8	R/TN	B Data	
9		unassigned	

**Use**

Switchable from **RS 232** without handshake to **RS 485 DSfG-compliant**. Can be assigned with **DSfG function** for converter and registration instances or RMG bus function. The DSfG interface implemented in the ERZ2000-NG also conforms to the current version of the technical specifications of the DSfG for flow computers in this case.

The operating mode for the COM 2 interface is adjusted in the menu **IB Serial interfaces** with coordinate **IB09 COM 3 operating mode**. The following adjustments are possible:

- Off
- Test
- DSfG
- RMG bus
- RMG bus-24K

There is a separate description for the RMG bus. It is used together with RMG PGCs (GC 9000) instead of the DSfG.

**COM 5 (modem)**

**Pin assignment**

Pin	Mode: RS 232
1	DCD
2	RxD
3	TxD
4	DTR
5	GND
6	DSR
7	RTS
8	CTS
9	RI

115

**Use**

RS 232 with handshake plus carrier plus ring. Usable for MODEM (DFÜ).  
 With connection of a modem, "Modem" must be selected in coordinate **IB21 COM 5 operating mode**.

**2.7.6 External modem connection**

1. The COM 5 interface is used for connection.
2. Modem type  
 The Phoenix industrial modem, type PSI-DATA/FAX-Modem/RS232, is the standard unit



**Figure 86: External modem**

### Note

After discontinuation of ISDN 2018, Phoenix no longer produces this mode. However, if it is still available, it can be used as described. In case of inquiries about modem connection, contact the RMG service department.

### 3. Connection

The ERZ2000-NG is connected to the external modem via a fully assigned RS232 cable, i.e. all 9 pins must be used 1:1.

### Note

The modem connection does not work if only the minimum version is assigned with Pin 2, 3 and 5.

### 4. Configuration

The modem can remain in the factory setting (all DIL switches OFF). The modem-init string and selection prefix must be adjusted on the ERZ2000-NG according to the local conditions.

**Example for a setting**

The setting must be made in the menu **IE DSfG Remote data transmission access:**

**IE06 Modem init. string**           ate0s0=1

**IE07 Dial prefix**                   atx3dt

**IE Remote data transmission access**

Access Line	Designation	Value	Unit	Variable
B 1	RDT address modem	OFF		myAdrD
D 2	RDT entity		D2	myInstD
D 3	State of modem	Waiting for modem		modemState
B 4	Bus identification	000000000000		buskennung
B 5	RDT ID	1111111111111111		dfueId
B 6	Modem init. string	ate0s0=1		mdmInitStr
B 7	Dial prefix	atx3dt0		dialPrefix
D 10	Time RDT param.	DD-MM-YYYY hh:mm:ss		dfuParChq
B 13	Carrier message	Suppress		anrufMsg
B 14	PTB-Message	Suppress		ptbZMsg
D 15	DSfG-B-IP state		listen	dsfgbState
D 16	DSfG-B-IP port		8000	dsfgbPort
B 17	Network interface	ETH1		dsfgbBind
B 18	RDT address IP	OFF		myAdri
B 19	entity filter IP	ABC		exListe

**Figure 87: DSfG data transmission**

**Meaning:**

- at   Prefix of a command line
- e0   Echo function deactivated
- s0=1 Set register 0 to 1, which means the number of alert characters after which the modem answers and establishes the connection, should be 1.
- x3   Response setting:  
Hayes Smartmode 300 compatible answers / blind dialing (extension)  
plus all CONNECT answers  
plus recognition of busy symbols
- dt   sound selection process (dp = pulse selection process)

If a different modem is used, there may be other commands, which are covered in the manufacturer's manual.

Additional settings in the menu **IB Serial interfaces:**

**IB Serial interfaces**

Access Line	Designation	Value	Unit	Variable	
B	1	Baud rate COM1	38400	baudC0	
B	2	B/P/S COM1	8N1	bpsC0	
B	3	COM1 operating mode	OFF	modeC0	
B	4	Baud rate COM2	115200	baudC1	
B	5	B/P/S COM2	7E1	bpsC1	
B	6	COM2 operating mode	Test	modeC1	
B	7	Baud rate COM3	19200	baudC3	
B	8	B/P/S COM3	7E1	bpsC3	
B	9	COM3 operating mode	OFF	modeC3	
B	10	Baud rate COM4	9600	baudC4	
B	11	B/P/S COM4	8E1	bpsC4	
B	12	COM4 operating mode	OFF	modeC4	
B	13	Baud rate Vo	2400	baudVO	
B	14	B/P/S Vo	7E1	bpsVO	
B	15	Vo operating mode	Vo	modeVO	
T	16	Timeout gas quality	60	min	gbhToMx
B	17	Register offset	0		reqOffs
B	18	Modbus address	1		mbAdr
B	19	Baud rate COM5	38400		baudC5
B	20	B/P/S COM5	8N1		bpsC5
B	21	COM5 operating mode	Modem		modeC5
B	22	Modbusaddr. COM1	1		mbAdrC0
B	23	Modbusaddr. COM2	2		mbAdrC1
B	24	Modbusaddr. COM3	0		mbAdrC3
E *	25	Address FLOWSIC	1		sickAdr
B	27	Modbus project	EGT		mbProj
I	28	COM5 DSR		0	dsrC5
I	29	COM5 RING		0	ringC5
I	30	COM5 DCD		0	dcdC5
B	31	Baud rate COM6	38400		baudC6
B	32	B/P/S COM6	8N1		bpsC6
B	33	COM6 operating mode	Univ.Modbus.Master		modeC6
B	34	Baud rate COM7	38400		baudC7
B	35	B/P/S COM7	8N1		bpsC7
B	36	COM7 operating mode	Univ.Modbus.Master		modeC7

Enter Cancel Load defaults Refresh

**Figure 88: Menu: IB Serial interfaces**

The parameters for operation of the serial interfaces (also DSfG-B and Modbus) are adjusted in this menu **IB Serial interfaces**.

The coordinate **IB15** is an internal interface that can be used for the original Vo counter of an encoder (ENCO).



**IB16** contains the collective **Timeout gas quality** for gas composition. The register offset for the Modbus register is adjusted in **IB17**. The joint Modbus address for COM 1, COM 2, COM 3 and TCP/IP can be entered with **IB18**.

With **IB21**, COM 5 can be configured for modem connection for "Modem" or "Dedicated line" (with external modem), e.g. DFÜ for DSfG-B. The Modbus addresses differing from the joint address **IB18** are specified in **IB22 – IB24**. The Modbus address of a FLOWSICK ultrasonic meter can be defined in **IB25**.

119

Coordinate **IB27 Modbus project** enables project-specific assignment of the Modbus register upwards from 9000.

"Transgas": Register assignment for data exchange with bus coupler for Transgas Portugal.

"EGT": Register assignment for **Eon Gas Transport** (Werne Project).

"Gascade": Register assignment for gas transport company Gascade

**The following applies for the operating mode of interfaces COM1, COM2, COM3 and COM4:**

Sending and receiving of characters can be checked with the "Test" setting. After activation, the interface designations and interface parameters are sent on the interface. With entry and/or receipt of a character, it is sent back as an echo.

Example for COM3:

The interface is configured as RS232 and connected to a PC. A terminal program is provided as a testing tool. The following is sent or displayed cyclically (e.g.):

C3, 9600, 8N1

With actuation, e.g. of PC button 5, display shows:

55

## 2.7.7 Connections

### 2.7.7.1 Inputs

#### Input characteristics

- **2-channel HF volume flow input with pulse metering and frequency measurement**

The appropriate frequency input must be selected in this menu; Inputs 5, 6, 7 and 8 offer higher resolution.

#### Channel 1: Volume measuring channel HF input

Measuring range	0.10 Hz to 6.0 kHz
Accuracy	0.01 Hz
U hys	1.0 V
U trg	3.0 V
Overvoltage protection	6.8 V with external module 18.0 V with internal module (galvanically isolated)

#### Channel 2: Volume comparison channel HF input

Same data as for Channel 1

- **2-channel LF volume flow input with pulse metering and frequency measurement**

#### Channel 1: Volume measuring channel LF input

Measuring range	0.00 Hz to 6.0 kHz
Accuracy	0.01 Hz
U hys	1.0 V
U trg	3.0 V
Overvoltage protection	6.8 V with external module 18.0 V with internal module (galvanically isolated)

#### Channel 2: Volume comparison channel LF input

Same data as for Channel 1

- **Volume input for digitally operating Vo counters**

Data transmission between the gas volume meter and flow computer take place uni-directionally and reactionless via a shielded, twisted pair of wires from the counter to the flow computer. The electrical characteristic data conforms to DIN 19234 (NAMUR).

121

**For further details about the Vo counter, refer to appendix H) Vo digital totalizer**

- **Up to 12 analogue inputs, including a pressure measurement input for analog signals and for HART protocol**

**Current measurement**

Range	0/4 to 25 mA
Resolution	20 bit
U max	2.5 V
Ri	250 Ω
Tk	< 15 ppm
Measuring time	50 ms
Overtoltage protection	6.8 V

Calibration of current inputs takes place at the factory, but correction can take place with the adjustment of the input variables pressure, temperature, etc.

**For further information, refer to *appendix C). Archive assignment, depth and identification***

**HART protocol connection SMART transmitter (optional)**

	<b>Two-wire system</b>
Communication	Simultaneously analog and digital
Protocol	HART master
Inputs	3 (optionally 6)
With EX isolation board (optional)	+ 2 inputs
Distribution of inputs	1 x pressure (reserved) 1 x temperature (reserved) Remainder -> Free availability

- **Up to 4 resistor inputs, a temperature measuring input for resistance measurement, up to 3 signals for delta-p measuring cells**

**Resistance measurement**

Type	PT 100 four-wire
Range	-20°C to +60°C
Resolution	0.01°C
Accuracy	0.05°C
Measuring time	50 ms

- **4 frequency inputs**

Measuring range	0.00 Hz to 6.0 kHz
Accuracy	0.01 Hz
U hys	1.0 V
U trg	3.0 V
Overvoltage protection	6.8 V with external module 18.0 V with internal module (galvanically isolated)

- **8 signal inputs for H/L gas switching, travel direction reversal and external freeze**

**Digital status inputs**

All inputs are galvanically isolated from the computer, but not from each other. The following can be used as signal transmitters: contact, open collector / drain, active push / pull

-U max	5 V
-I max	13 mA
f max	10 Hz
Overvoltage protection	6.8 V

- **Reserve signal inputs**

The ERZ2000-NG offers additional free inputs for which the same data as for the "normal" signal inputs applies. These free inputs can be assigned with functions and events, statuses, additional counter, etc. can be detected and stored in DSfG archives.

**Appendix E) "Various circuit diagrams for inputs" provides some input circuit diagrams**

**2.7.7.2 Output characteristics**

**Current outputs**

Quantity	4
Range	0-20 mA or 4-20 mA
Resolution	12 bit
Ohmic resistance	700 Ω
Overvoltage protection	from 33 V, galvanically isolated

123

**Signal outputs**

Quantity	8
U max	24 V DC
P max	150 mW
Ic max	100 mA
U <sub>CEsat</sub>	1.2V or Ron = 50 Ohm
F max	400 Hz
Overvoltage protection	33 V, galvanically isolated

**Pulse outputs**

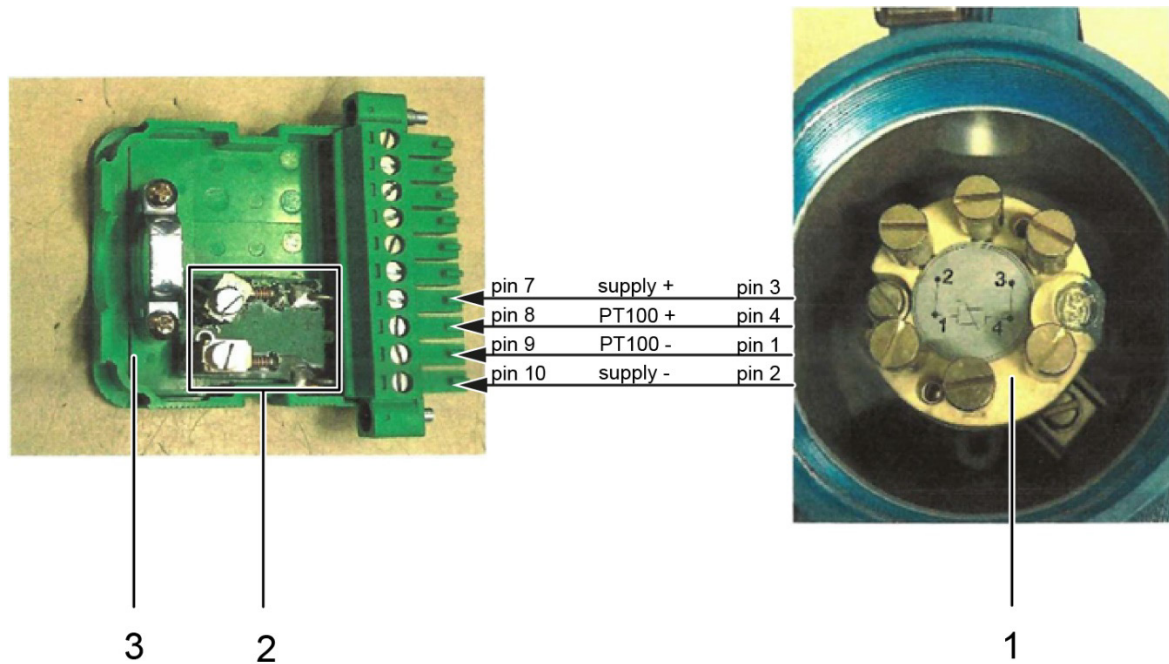
Quantity	4
t <sub>min off</sub>	16 ms
t <sub>max off</sub>	230 ms
t <sub>min on</sub>	16 ms
t <sub>max on</sub>	230 ms
Ic	100 mA
U <sub>CEsat</sub>	1.2V
F max	400 Hz
Overvoltage protection	33 V, galvanically isolated

**Alarm and warning status outputs**

U max	24 V DC
I max	100 mA
P max	100 mW
R <sub>Dson</sub>	<= 50 Ohm
Photomos relay	
Ic	100 mA
Ron	50 Ohm
Overvoltage protection	33 V, galvanically isolated

**Appendix G) "Various circuit diagrams for outputs" provides some output circuit diagrams**

## 2.7.7.3 Connecting a PT100 without series resistors



**Figure 89:** Connection of a PT100 without series resistors to a connector plug

Item	Designation	Item	Designation
1	Connection head of the PT100	2	Auxiliary board
3	Connector plug		

### Note

#### Connection of a PT100 without series resistors

**When connecting a PT100 temperature sensor without series resistors to the ERZ 2000-NG flow computer, a plug with an auxiliary circuit board must be used!**

#### Procedure for connecting the PT100 to the ERZ 2000-NG

Depending on the explosion protection class, the PT100 temperature sensor is connected to the following connection terminals on the device:

- for **Ex-d sensors**: connection terminal **X5**
- for **Ex-i sensors**: connection terminal **X10** (Ex-IO card)

To connect the PT100 to the connector plug with auxiliary circuit board, proceed as follows (see *Figure 89*).

1. Connect **pin 1** of the PT100 to **pin 9** of the connector plug (PT100 -).
2. Connect **pin 2** of the PT100 to **pin 10** of the connector plug (supply -).
3. Connect **pin 3** of the PT100 to **pin 7** of the connector plug (supply +).
4. Connect **pin 4** of the PT100 to **pin 8** of the connector plug (PT100 +).
5. Insert the connector plug into the required connection terminal (X5 or X10) on the rear of the ERZ 2000-NG.

125

### 2.7.8 Activation of inputs and outputs

The required inputs and outputs can be activated in menu **E Mode**, submenu **EI Configuration** by a "Super user" (*chapter 2.3 Access protection for data and settings*). The number of activated inputs determines whether the ERZ2000-NG scans the corresponding terminals in order to determine the measurement. If the value of the coordinate under **EI Configuration** is "0", no measurement takes place on this channel.

#### Note

**Registered inputs that are not used are still checked. Such inputs can produce error messages (e.g. cable breakage)**

### EI Configuration

Access Line	Designation	Value	Unit	Variable
S	1	No.resist.meas.ch.	0	rAnzahl
S	2	No.nonex currents	3	iAnzahl
S	3	No. freq. meas.	4	fAnzahl
B	4	No. of cur.outputs	4	iOutAnz
B	5	No. cont.outp.	8	kOutAnz
B	6	No. pulse outputs	4	pOutAnz
B	7	No. of frq.outputs	1	fOutAnz
S	8	FPGA quartz freq.	31999564	Hz fpgaQuarz
W *	9	Quartz meas. CPU	29491200	Hz cpuQuarz
S	10	L calib.pt. current	4.0000	mA lukaI
S	11	U calib.pt. current	20.0000	mA iokaI
S	12	L calib.pt. ohm(T)	-10.0000	°C tukaI
S	13	U calib.pt. ohm(T)	60.0000	°C tokaI
B	14	Gradient active	No	grdWatch
B	15	Meas.warn.lim.act.	Yes	wqwWatch
B	16	Drag indic. active	Yes	shzWatch
B	17	Means active	No	miwWatch
B	18	Show base values	No	orqWatch
B	19	Flow warn.lim.act.	Yes	wgwfWatch
B	20	Comp.warn.lim.act.	Yes	wqkWatch
B	21	Cur. outputs check	No	SaCtrl
W *	22	ADC ref. voltage	2500.00	mV adcVref
W *	23	Rref cur.measur.	43.00	Ohm I_Ref
W *	24	Rref PT100 meas.	274.00	Ohm PT100_Ref
W *	25	Rref PT1000 meas.	3000.00	Ohm PT1000_Ref
W *	26	Rref kTY measur.	3240.00	Ohm kTY_Ref

Figure 90: Activation of inputs and outputs in menu "EI Configuration"

If a PT 100 is connected, differentiation between whether the Ex protection is external or internal Ex protection must take place.

**⚠ Caution**  
 External Ex protection (Ex-d): Terminal X4, EI01 value = 1, EI31 value = 0

**⚠ Caution**  
 Internal Ex protection (Ex-i): Terminal X10, EI01 value = 0, EI31 value = 1

**Note**



**F1, F2, F3 and F4 are combined with a pulse counter function for frequency inputs and thus suitable for volume measurement. The standard pre-assignment:**

**F1 for the measuring channel and**

**F2 for the comparison channel.**

**Frequencies F5, F6, F7 and F8 are assigned for density (F5), standard density (F6) and velocity of sound (F8).**

127

### Note

**This frequency measurement has a different time basis and is capable of more precise frequency measurement and higher resolution. With activation of the frequency inputs, bear in mind that the frequencies 1 to 4 (volume) must always be included.**

### Example:

Flow computer with HF 2 and 3, density and standard density

7 frequency inputs must be activated:

- 1 to 4 for volume
- 5 for density
- 6 and 7 for standard density

## 2.7.9 Assignment of "physical values"

The assignment of physical values to the inputs and outputs is discussed in the following chapters.

### 2.7.10 MA Input / output function key

#### MA Input/output function key

Designation	Value	Unit	Column	Jump target
I1a	0.000	mA	MB	<a href="#">Current output 1</a>
I2a	20.148	mA	MC	<a href="#">Current output 2</a>
I3a	20.087	mA	MD	<a href="#">Current output 3</a>
I4a	4.000	mA	ME	<a href="#">Current output 4</a>
P1	0	pulses	MF	<a href="#">Pulse output 1</a>
P2	0	pulses	MG	<a href="#">Pulse output 2</a>
P3	0	pulses	MH	<a href="#">Pulse output 3</a>
P4	0	pulses	MI	<a href="#">Pulse output 4</a>
A1	0		MJ	<a href="#">Contact output 1</a>
A2	1		MK	<a href="#">Contact output 2</a>
A3	1		ML	<a href="#">Contact output 3</a>
A4	1		MM	<a href="#">Contact output 4</a>
A5	1		MN	<a href="#">Contact output 5</a>
A6	1		MO	<a href="#">Contact output 6</a>
A7	1		MP	<a href="#">Contact output 7</a>
A8	1		MQ	<a href="#">Contact output 8</a>
Fo	0.000	Hz	MR	<a href="#">Frequency output 1</a>
I1e	0.0025	mA	NA	<a href="#">Current input 1</a>
I2e	0.0000	mA	NB	<a href="#">Current input 2</a>
I3e	0.0000	mA	NC	<a href="#">Current input 3</a>
I4e	0.0000	mA	ND	<a href="#">Current input 4</a>
I5e	0.0000	mA	NE	<a href="#">Current input 5</a>
I6e	0.0000	mA	NF	<a href="#">Current input 6</a>
I7e	0.0000	mA	NG	<a href="#">Current input 7</a>
I8e	0.0000	mA	NH	<a href="#">Current input 8</a>
R1	0.00	Ohm	NI	<a href="#">Resist.inp. 1</a>
R2	0.07	Ohm	NJ	<a href="#">Resist.inp. 2</a>
F1	0.0000	Hz	NL	<a href="#">Frequency input 1</a>
F2	0.0000	Hz	NM	<a href="#">Frequency input 2</a>
F3	0.0000	Hz	NN	<a href="#">Frequency input 3</a>
F4	0.0000	Hz	NO	<a href="#">Frequency input 4</a>
F5	0.0000	Hz	NP	<a href="#">Frequency input 5</a>
F6	0.0000	Hz	NQ	<a href="#">Frequency input 6</a>
F7	0.0000	Hz	NR	<a href="#">Frequency input 7</a>
F8	0.0000	Hz	NS	<a href="#">Frequency input 8</a>
E1-8	-----	bin	NT	<a href="#">Contact inputs</a>

Refresh

**Figure 91: Menu MA Input / output function key**

The assignments of inputs and outputs are shown in menu MA Input / output function key.

## Inputs

The assignment of inputs to "physical values" takes place in menus "A Measurements", "B Components", etc. The units of these measured variables are also defined in these menus in order to ensure correct transfer of the values. Normally, the manufacturer and type of transmitter of the physical variable should also be defined here, particularly for custody-transfer applications, for which there are certified and approved transmitters. In *chapters 4 Transmitters, 5 Flow meters and 6 Parameter of the gas*, the explicit assignment is covered and explained in detail.

The free inputs can be assigned functions and the measurement values can be written to archives (e.g. to the free archive *chapter 2.5.6 Archive*). There is a selection of functions for each input, as is the case with the standard inputs for pressure or temperature. Limit ranges and significances can also be defined. There is an input field available for each measurement value for assignment of a name. Special measurements are found in menu **O Miscellaneous** (see *chapter 4.4 Special measurements*).

The 8 contact inputs can be assigned to messages, etc. The message can be a notice, warning or alarm and assigned arbitrary text. Entries are also made in the DSfG log book. The 8 contact inputs can also be optionally assigned as 6 special counters or 8 binary inputs.

### Note

**The special counters are designed for slow metering processes and their maximum frequency is limited to 5 Hz.**

The 8 binary inputs can be assigned free text and a meaning (notice, warning or alarm). The corresponding entries are made in the log book.

Up to 4 routes / billing modes can be selected per switch / contact. Assignment of the switches / contacts to the terminals takes place in menu **EC Billing mode**, sub-item **EC04 Bill. mode selection** (see *chapter 5.2.1 EC Billing mode*). The following choices are available:

Billing mode 1/2/3/4

1 contact switches in 2 directions

2 contacts switch in 2 directions

2 contacts switch in 4 directions

4 contacts switch in 4 directions

Measurement value  
 Original encoder counter  $V_c$   
 DZU (digital counter transmission) direction  
 Flow direction (when switching from forwards/backwards)  
 Transmission of analysis data (GC 1/2)  
 or Modbus data

If the billing mode is assigned to the original encoder counter  $V_o$  or a digital transmission takes place (e.g. via Instance F), no sources must be assigned. If an illogical case arises, a switch to the counters for undefined direction takes place automatically. All settings take place in menu **EC Billing mode**.

A setting can be made in coordinate **EC21 BM at revision** for whether the ERZ2000-NG changes automatically in case of a revision of the billing mode (access only possible as super user). The operating code in coordinate **EC22 BM0 Suppression** can define whether a changeover to the special counter set for undefined direction should take place in case of an implausible contact assignment (see above).

The 4 special counters are assigned to frequency inputs 1 to 4 as an additional counter. A control counter can be activated here independently of the conversion. The special counters – like the main counter for custody-transfer applications – have one digit before and after the decimal (see *chapter 2.5.1.4 Counters* and *2.5.1.5 Customer-specific counters (customer counters)*). Like the "normal" counters, the special counters can be assigned value and unit.

### Note

**These counters are permanently connected to the input and there is no differentiation between main or disturbed quantities. Moreover, no characteristic curve correction or leak flow volume suppression takes place.**

Unit and value can be adjusted depending on the conversion. The portion after the decimal is stored in a residual counter. The control counter is activated when the setting of coordinate **NL10 Weighting** is greater than 0 (see *chapter 2.7.13 NL Frequency input 1*).

### 2.7.11 NA Current input 1

#### NA Current input 1 terminal X5-1, X5-2

Access	Line	Designation	Value	Unit	Variable
A *	1	Current 1	0.0025	mA	<a href="#">i1</a>
I	2	HART measured value	0		<a href="#">ih1</a>
D	3	Uncalib. current	0.0003	mA	<a href="#">iu1</a>
D	4	Uncalib. mean	0.0003	mA	<a href="#">iu1Miw</a>
I	5	Converter value	0000005E	hex	<a href="#">iuhex1</a>
D	6	Running timeout	0	s	<a href="#">i1TO</a>
S	9	Meas. strategy	Standard		<a href="#">i1Adc</a>
S	10	Lower calib.val.	4.0002	mA	<a href="#">iuUmA1</a>
S	11	Upper calib.val.	20.0099	mA	<a href="#">iuOmA1</a>
S	13	Transd.supply	OFF		<a href="#">ixmt1</a>
G *	14	Float.-point not.	%0.4f		<a href="#">ie1Frm</a>
D	15	Beneficiary	Unknown		<a href="#">i1Dst</a>
S	16	HART oper. mode	OFF		<a href="#">ih1Mod</a>
J	17	HART unit code	0		<a href="#">ih1Dim</a>
J	18	HART manufact. code	0		<a href="#">ih1Manuf</a>
J	19	HART type code	0		<a href="#">ih1Dev</a>
J	20	HART identification	0		<a href="#">ih1Id</a>
D	21	Timeout HART	0	s	<a href="#">ih1TO</a>
D	22	HART status	0		<a href="#">ih1St</a>

Refresh

Figure 92: Menu NA Current input 1

Current input 1 is shown here as an example for all current inputs. These current input menus are essentially display menus. Coordinate **NA15 Beneficiary** displays which function uses this measurement, i.e. who is the beneficiary (the input is not used in this case).

### 2.7.12 NI Res. input 1

#### NI Resistance measurement 1 terminal X5-7, X5-8, X5-9, X5-10

Access Line	Designation	Value	Unit	Variable
A *	1 Resistance 1	0.00	Ohm	r1
D	2 Calibr.temperature	-242.0213	°C	r1qc
D	3 Uncalib.temperature	-242.0213	°C	tu1
D	4 Uncalib. T mean	-242.0213	°C	tu1Miw
I	5 Converter value	00000000	hex	ruhcx1
D	6 Running timeout	31	s	r1TQ
S	10 Lower calib.val.	-9.7910	°C	tuUqc1
S	11 Upper calib.val.	60.1503	°C	tuOqc1
B	12 Open.circ control	Yes		ptLtb1
E *	13 Measuring range	PT100		ptMessb1
G *	14 Float.-point not.	%.2f		r1Frm
D	15 Beneficiary	Unknown		r1Dst
D	16 Spec.val.dev.AD0	0.00	%	r1Df0
D	17 Spec.val.dev.AD1	0.00	%	r1Df1
D	18 Spec.val.dev.AD2	0.00	%	r1Df2
D	19 Open-circ.fault	0000		r1Ltb
D	20 Special dev. AD0	0.00	%	r1Df0G
D	23 Uncalib.resistance	0.00	Ohm	ru1
D	24 Uncalib. mean	0.00	Ohm	ru1Miw
I	26 Open-circ.monit.AD0	0		r1Ad0
I	27 Open-circ.monit.AD1	0		r1Ad1
I	28 Open-circ.monit.AD2	0		r1Ad2
D	29 R1 opencirc ready	0		ltb1Da
S	30 calib. low PT500	-10.0000	°C	tuUPT500
S	31 calib. high PT500	60.0000	°C	tuOPT500
S	32 calib. low PT1000	-10.0000	°C	tuUPT1000
S	34 calib. high PT1000	60.0000	°C	tuOPT1000

Enter Cancel Load defaults Refresh

Figure 93: Menu NI Res. input 1

Resistance measurement 1 is shown here as an example for all resistance measurements. These menus are essentially display menus. Coordinate **NA15 Beneficiary** displays which function uses this measurement, i.e. who is the beneficiary (the input is not used in this case).

### 2.7.13 NL Frequency input 1

#### NL Frequency input 1 X8 or X9

Access Line	Designation	Value	Unit	Variable
I 1	Frequency 1	0.0000	Hz	f1
D 2	smoothed	0.0000	Hz	fm1
I 3	Input pulses 1	0	pulses	eingangImp1
D 4	Running timeout	0	s	f1TO
G * 6	Float.-point not.	% <b>.4f</b>		f1Frm
A * 7	Assignment	<b>Term. X8-7,X8-8</b>		f1st
N 8	Integer part	0	[]	cz1
N 9	Fraction part	.000000	[]	cz1R
B 10	Weighting	<input type="text" value="0"/>		ckv1
B 11	Unit	<input type="text" value=""/>		cz1Dim
B 12	Symbol	<input type="text" value="Kontroll1"/>		cz1Symbol
D 15	Beneficiary	Qm freq. main		f1Dst

Figure 94: Menu NL Frequency input 1

Frequency input 1 is shown here as an example for all frequency inputs. These menus are essentially display menus. Coordinate **NL01 Frequency 1** shows the input frequency, which is assigned to operating value measuring channel 1 in this case (see coordinate **NL15 Beneficiary**).

With use of the Ex board, input **NL10 Weighting** is free and can be used for other counter inputs. The assessment and the unit must be entered here appropriately.

The ERZ2000-NG has 4 pulse / frequency inputs. Usually frequency 1 and 2 are used for a turbine, but often (e.g. in case of Ultrasonic meter) they are unused. They may than be used for example for another flow rate meter. In NL10 (pulse weight), NL11 (unit) and NL12 (name of the unit) a correct counting has to be adjusted. The quantities are accumulated on NL08 and NL09 and are archived in group 16 (extra inputs).

### 2.7.14 NT Contact inputs

#### NT Contact inputs terminal X7,X8

Access	Line	Designation	Value	Unit	Variable
D	1	Binary pattern	-----	bin	<a href="#">ktkEBin</a>
I	2	Input pattern	0		<a href="#">ktkEin</a>
D	3	Used contact	0		<a href="#">ktkEUse</a>
D	4	Inverting mask	0		<a href="#">ktkEinMsk</a>
D	6	Target contact 1	(...)		<a href="#">ktkEDst0</a>
D	7	Target contact 2	(...)		<a href="#">ktkEDst1</a>
D	8	Target contact 3	(...)		<a href="#">ktkEDst2</a>
D	9	Target contact 4	(...)		<a href="#">ktkEDst3</a>
D	10	Target contact 5	(...)		<a href="#">ktkEDst4</a>
D	11	Target contact 6	(...)		<a href="#">ktkEDst5</a>
D	12	Target contact 7	(...)		<a href="#">ktkEDst6</a>
D	13	Target contact 8	(...)		<a href="#">ktkEDst7</a>
D	14	Running timeout	7	s	<a href="#">ktkEinTO</a>
T	15	inv. contact 1	No	▼	<a href="#">ktkEInv1</a>
T	16	inv. contact 2	No	▼	<a href="#">ktkEInv2</a>
T	17	inv. contact 3	No	▼	<a href="#">ktkEInv3</a>
T	18	inv. contact 4	No	▼	<a href="#">ktkEInv4</a>
T	19	inv. contact 5	No	▼	<a href="#">ktkEInv5</a>
T	20	inv. contact 6	No	▼	<a href="#">ktkEInv6</a>
T	21	inv. contact 7	No	▼	<a href="#">ktkEInv7</a>
T	22	inv. contact 8	No	▼	<a href="#">ktkEInv8</a>

Enter   Cancel   Load defaults   Refresh

**Figure 95: Menu NT Contact inputs**

Assignment to "MRG" functions, measurement positions, etc. takes place with menu **NT Contact inputs**.



### 2.7.15 NU Current input 9 Exi

#### NU Current input 9 Exi

Access	Line	Designation	Value	Unit	Variable
A *	1	Current 9	<b>0.5422</b>	mA	<a href="#">i9</a>
I	2	HART measured value	0		<a href="#">ih9</a>
I	3	Uncalib. current	0.5422	mA	<a href="#">iu9</a>
D	4	Uncalib. mean	0.5377	mA	<a href="#">iu9Miw</a>
D	6	Running timeout	0	s	<a href="#">i9TQ</a>
S	8	EXI-Mod. calibr.	No		<a href="#">i9KalMod</a>
S	10	Lower calib.val.	4.0000	mA	<a href="#">iuUmA9</a>
S	11	Upper calib.val.	20.0000	mA	<a href="#">iuOmA9</a>
G *	14	Float.-point not.	<b>%0.4f</b>		<a href="#">ie9Frm</a>
D	15	Beneficiary	Unknown		<a href="#">i9Dst</a>
S	16	HART oper. mode	OFF		<a href="#">ih9Mod</a>
J	17	HART unit code	0		<a href="#">ih9Dim</a>
J	18	HART manufact. code	0		<a href="#">ih9Manuf</a>
J	19	HART type code	0		<a href="#">ih9Dev</a>
J	20	HART identification	0		<a href="#">ih9Id</a>
D	21	Timeout HART	0	s	<a href="#">ih9TQ</a>
D	22	HART status	0		<a href="#">ih9St</a>

Refresh

Figure 96: Menu NU Current input 9 Exi

The additional **NU Current input 9** and **NU Current input 10** become possible with use of the Ex board.

**Note**

(Slots 11 and 12 are reserved for the 2nd Ex board).

### 2.7.16 NY Resistance measurement 3

#### NY Resistance measurement 3

Access Line	Designation	Value	Unit	Variable
A *	1 Resistance 3	<b>136.59</b>	Ohm	r3
D	2 Calibr.temperature	94.9564	°C	r3gc
D	3 Uncalib.temperature	95.0280	°C	tu3
D	4 Uncalib. T mean	95.0279	°C	tu3Miw
D	6 Running timeout	0	s	r3TQ
S	8 EXI-Mod. calibr.	No		r3KalMod
S	10 Lower calib.val.	-10.0070	°C	tuUqc3
S	11 Upper calib.val.	60.0450	°C	tuOqc3
B	12 Open.circ control	No		ptLtb3
G *	14 Float.-point not.	<b>%0.2f</b>		r3Frm
D	15 Beneficiary	Unknown		r3Dst
I	23 Uncalib.resistance	136.62	Ohm	ru3
D	24 Uncalib. mean	136.62	Ohm	ru3Miw

Enter Cancel Load defaults Refresh

Figure 97: Menu NY Resistance measurement input 3

The additional **NY Resistance measurement 3** becomes possible with use of the Ex board. **NZ Resistance measurement 4** can also be used with the 2nd Ex board.

2.7.17 MB Current output 1

**MB Current output 1 terminal X4-1, X4-2**

Access	Line	Designation	Value	Unit	Variable
D	1	Current	0.000	mA	I1out
D	2	Physical value	(...)		I1Org
D	3	Smoothed orig.val.	0		I1OrgG
I	4	D/A converter value	0010	hex	I1BinMu
B	5	Assignment	Pressure		I1Ausw
B	6	Extended assignm.	Edit		I1More
B	7	Lower mapping	0		I1Abbu
B	8	Upper mapping	1000		I1Abbo
B	9	Averaging factor	0		I1MiwFakt
B	10	Operating mode	Default		I1MdBtr
B	11	Operation if fault	Rise/decrease		I1MdErr
B	12	Rise/decr.w.fault	0	mA	I1ErrOffs
B	13	Default current	0.000	mA	I1Vg
B	14	Test current	10.000	mA	I1Eich
S	15	Lower calib.val.	4.022	mA	I1Kalu
S	16	Upper calib.val.	20.132	mA	I1Kalo
B	17	Method	Quick		I1Method
G *	18	Float.-point not.	%0.3f		ia1Frm

Enter Cancel Load defaults Refresh

Figure 98: Menu MB Current input 1

This current output channel 1 is shown as an example for all 4 current outputs.

The main selection of the measurement takes place in coordinate **MB05 Assignment**. The most frequently used values are designed for current output. The output is optimized for regulating purposes of pressure, temperature and flow values. If you would like to output measurement variable not listed here, program "Expanded selection" and enter a measurement variable with **MB06 Extended assign**. For this purpose, coordinate **MB06 Extended assign**. offers the possibility of jumping to another menu by clicking on [edit](#). The suitable variable for the current output can be selected from all available variables and measurements.

If a parameter is selected in **MB05 Assignment**, it is displayed under **MB02 Physical value** in consideration of the correct unit. Its output value is assigned with a correction factor, which is calculated from the lower and upper calibration value and is standardized to its limit ranges (**MB07 Lower mapping** and **MB08 Upper mapping** (output current)) and the operating mode setting (**MB10 Operating mode**).

 **Warning**

If the physical value exceeds the defined value, a warning message is generated.

The value in coordinate **MB09 Averaging factor** determines the smoothing of the current. A setting between 0 and 0.99999 should be adjusted in consideration of the following meaning:

0 (minimum) = smoothing deactivated

1 (maximum) = infinite smoothing.

The operating mode for the error case is defined in coordinate **MB11 Operation if fault**. If the physical variable to be output leaves the figure range, the current output current is increased or decreased by the value adjusted in **MB12 Rise/decr.w.fault**.

It is possible to output a constant current (**MB14 Test current**) independently of a measurement for testing purposes. The desired value is entered in the test current parameter and activated in operating mode.

The output of the current can take place according to 3 methods in **MB17 Method**.

<b>slow</b>	Output method for printers or displays, etc. The output current is updated and held for one second every full second. The output current includes digital stages.
<b>quick</b>	Output method for regulation. The output current is calculated with each recalculation of the physical output value. The frequency of recalculation can be read under <b>FD01 Cycle duration</b> . The output current follows the physical output value directly in the scope of the conversion speed. It is held until a new output value is provided. The output current includes digital stages.
<b>linear sweep</b>	Output method which can be used if a downstream regulator reaction is oversensitive to digital stages but can circumvent them with a constant dead time of one second. A new current output value is calculated every full second. Then, the current output is set to the new value, but not immediately (stage); it takes place in 100 increments of 10 milliseconds each, starting from the last value, on a continuous ramp. The output current is smooth but delayed one second.

### 2.7.18 MF Pulse output 1

#### MF Pulse output 1 terminal X3-1, X3-2

Access Line	Designation	Value	Unit	Variable
A *	1	Pulse totalizer	0	pulses <a href="#">P1Ausgabe</a>
A *	2	Part.exec.pulses	.0	pulses <a href="#">P1Rest</a>
A *	3	Storage	.0	pulses <a href="#">P1Imp</a>
A *	4	Frequency	0	Hz <a href="#">P1PFreal</a>
I	5	HW storage	0	pulses <a href="#">P1HImp</a>
E *	10	Assignm. meas.val.	Pulse group test	<a href="#">P1Mod</a>
E *	11	Assignm. main/dist.	Always	<a href="#">P1HS</a>
E *	12	Assignm. to BM	1	<a href="#">P1AM</a>
E *	13	Pulse value	1	<a href="#">P1PW</a>
E *	14	Max. pulse freq.	10	Hz <a href="#">P1PF</a>
E *	15	Strategy	Smooth	<a href="#">P1Form</a>
E *	16	Overflow comes	100.0	pulses <a href="#">P1MxHyst</a>
E *	17	Overflow goes	10.0	pulses <a href="#">P1MnHyst</a>
G *	18	Float.-point not.	% .1f	<a href="#">P1Frm</a>
E *	19	Transit	OFF	<a href="#">P1Trans</a>
Q	20	Pulses for testing	0.0	pulses <a href="#">P1Test</a>

Enter Cancel Load defaults Refresh

Figure 99: Menu MF Pulse output 1

This pulse output 1 is shown as an example for all 4 pulse outputs. Data, calculated values, etc. can be selected with the various functions and mapped on the pulse output.

**Note**

Since the frequency outputs 1 and 2 (port X3:1/2 and X3:3/4) are generally intended for the volume flow at measurement and base conditions, these are subject to the calibration lock, the other two frequency outputs are not.

The current situation with the pulse output, remainder in the buffer, output frequency, etc. is displayed in coordinates **MF01 Pluse counter** to **MF04 Frequency**.

There are more possibilities in addition to the assignment of the output value to a measurement in **MF10 Assignment meas.val.:**

- direct output of the HF input
- the number of pulses entered in line 20 can be output as a single pulse group or cyclically, every second.

Pulses are output in parallel with either the main totalizer or the disturbance totalizer or always in coordinate **MF11 Assignment main/dist..**

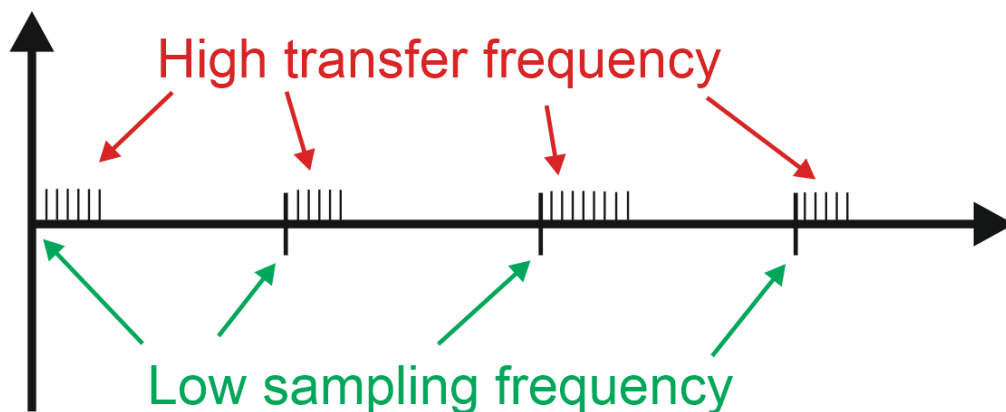
Assignment of the output mode with respect to the billing mode takes place in **MF12 Assignm. to BM**. The pulse accumulation takes place when the current billing mode corresponds to one of the modes listed here. Example:

The setting here should be "134". The pulse accumulation takes place in billing mode 1, 3 or 4. There is no accumulation in billing mode 2.

The ERZ2000-NG offers the possibility to change the pulse length at the pulse outputs. The coordinate **E15 strategy** is used for this purpose.

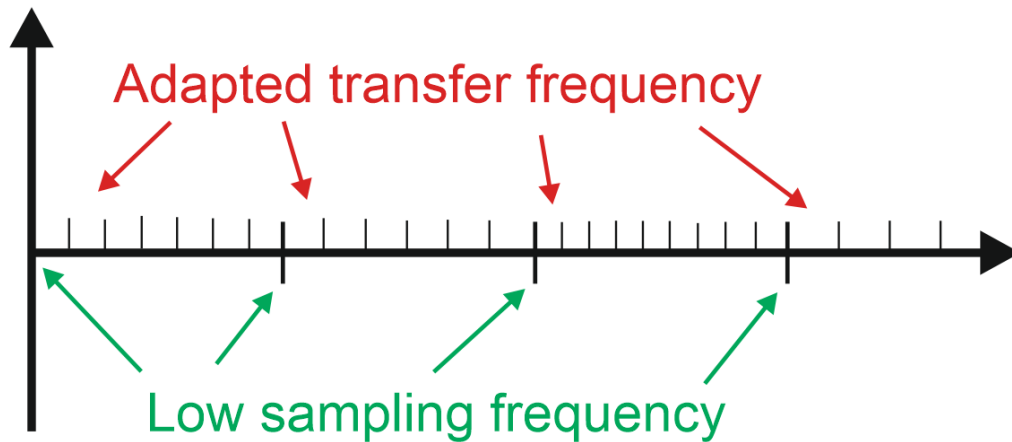
If pulses have accumulated during a measurement, they can be transferred in different ways at a low sampling frequency (e.g. 10 Hz):

Strategy "rough":



**Figure 100: Transfer frequency "rough"**

Strategy "smooth":



**Figure 101: Transfer frequency “smooth”**

If the strategy "rough" is selected, all accumulated pulses are transferred as quickly as possible (e.g. at 100 Hz) at each transfer time point (here every 0.1 s).

If the "soft" strategy is selected, the accumulated pulses are distributed *evenly* over the time interval. The resulting frequency is then of course smaller, sometimes even significantly smaller.

If a flow rate value is derived from the counting frequency, it is recommended to select the **E15 strategy** "smooth" for control purposes. Rough" can lead to absurd distortions; "soft", on the other hand, wears out the original flow behavior, but corresponds more to a damping averaging.

If the pulse output buffer exceeds the value specified in **MF16 Overflow comes**, the message

W70-0 Pulse 1 > max

is set. If the pulse output buffer undercuts the value programmed in **MF17 Overflow goes**, the message is withdrawn.

## 2.7.19 MJ Contact output 1

### MJ Contact output 1 terminal X1-1, X1-2

Access	Line	Designation	Value	Unit	Variable
I	1	Current position	0		<a href="#">K1Out</a>
D	2	Physical value -> <a href="#">AB01</a>	0.55000	MPa	<a href="#">K1Org</a>
B	3	Operating mode	Pot ~~~ _~~~		<a href="#">K1Mod</a>
B	4	Assignment	<a href="#">Edit</a>		<a href="#">K1Ausw</a>
B	5	Inversion	No		<a href="#">K1Inv</a>
B	6	Min. threshold	0	MPa	<a href="#">K1SMn</a>
B	7	Max. threshold	1E+006	MPa	<a href="#">K1SMx</a>

**Figure 102: Menu MJ Contact output 1**

Like before, **MJ Contact output 1** is presented as an example for all contact outputs.

The **MJ03 Operating mode** of the contact determines the source that switches the contact. In operating modes "pot", "cap", "value>max" or "value<min", a physical measurement variable must be assigned by clicking on [edit](#) under **MJ04 Assignment**, then a selection menu appears. The thresholds **MJ06 Min. threshold** and/or **MJ07 Max. threshold** must also be defined for these operating modes. The threshold value in these coordinates is entered with the assigned unit. The lower threshold value only has an effect in operating modes "cap", pot and value>min and the upper threshold has an effect in the operating modes cap, pot and value<max. **MJ05 Inversion** enables inversion of the contact function.

### Example

A threshold value switch (pressure) switches from high to low (pot).



## 2.7.20 MR Frequency output 1

### MR Frequency output channel 1 terminal X2-7, X2-8

Access	Line	Designation	Value	Unit	Variable
A *	1	Cur. frequency	0.000	Hz	F1out
A *	2	Physical value	(...)		F1Org
A *	3	rating of pulses	0	P/m3	implWrt
E *	5	Assignment	Percent. flow rate		F1Ausw
E *	6	Extended assignm.	<a href="#">Edit</a>		F1More
E *	7	Lower mapping	0		F1Abbu
E *	8	Upper mapping	100		F1Abbo
B	9	Averaging factor	0		F1MiwFakt
E *	10	Operating mode	OFF		F1MdBtr
B	13	Default frequency	0.000	Hz	F1Vq
B	14	Test frequency	2500.000	Hz	F1Eich
G *	18	Float.-point not.	%.3f		Fa1Frm
I	19	Act. frequency	0.000	Hz	F1Istf
D	20	Absolute error	0.000	Hz	F1Err

Enter Cancel Load defaults Refresh

Figure 103: Menu MR Frequency output 1

This frequency output is a help function in case the flow computer is also the main totalizer for a connected ultrasonic meter. A frequency signal is required from the ultrasonic gas meter for pre-testing / calibration / test stand testing. This signal is provided for comparison with a reference device. A currently more common alternative is use of the MODBUS for transmission of the current values.

The **MR05 Assignment** of the frequency output to one of the pre-adjusted and selectable measurement variables (different flow rates and flows) takes place here. If the pre-adjusted selection is not sufficient, any other arbitrary variable can be assigned in a selection menu that opens when the user clicks on [edit](#) in coordinate **MR06 Extended assignm.**.

The following **MR10 Operating modes** are available:  
 "off", "0-1000Hz", "0-2000Hz", "0-2500Hz", "Default" and "Test frequency"

If "Default" is selected, the setpoint of the setpoint of the frequency should be entered in **MR13 Default frequency**. For the "Test frequency" operating mode, the setpoint of the frequency should be specified in **MR14 Test frequency**. The actual value of the frequency output is displayed in **MR19 Act. frequency**.

A deviation from ACTUAL to setpoint frequency if possible if the setpoint cannot be represented by the internal binary divisor without remainder. The deviation is shown in **MR20 Absolute error**.

### 2.7.21 Revision switch

When the revision is switched on, the pulse outputs are switched off in the ERZ2000-NG and the revision bit is set in the data records of the DSfG. In menu **E Mode**, submenu **ED Parameter access**, the revision switch can be switched from operation (normal operation, i.e. no revision) to revision and revision via contact.

There are 2 revision modes that can lead to different operating modes together with the functions in the coordinates **ED13 Total. in revision** ("running"/"at rest"), **ED14 Temp. at revision** ("live value"/"retained value") and **ED15 Pressure with revision** ("live value"/"retained value").

#### Note

The coordinates ED13, 14 and 15 can only be changed with Super user authorization after opening the calibration seal.

With "revision" or "rev. via contact", coordinate **ED13 total. in revision** must be set to "Running", "At rest" or "Fault", e.g. the totalizer continues to run during the revision, it is at rest or displays an error.

During the revision, temperature and pressure remain on the last measured value before the start of the revision "retained value" is activated in coordinate **ED14** and **ED15**. If "live value" is adjusted here, the measurement of these parameters continues. The different device behaviors are clarified from parameterization examples:

**Examples for tests of totalizers in series connection or for totalizer simulations are provided in *appendix I) Examples for use of the revision switch***

# 3 Communication and bus systems

## 3.1 Bus systems

In the meantime, bus systems are often used with which various data can be transmitted, particularly when a measurement transmitter is already performing an (first) evaluation of the measured data. Then, the pure measurements are normally not transmitted, rather some (or all) derived billing variables.

145

With billing values, the same billing bases / requirements must be applied. Rounding errors can be minimized for internal calculation of non-rounded measurements which must also be transmitted. Further deviations arise when different time intervals or other assignments of the measuring time occur.

Different bus systems are available for selection for all measurements under operating mode:

DSfG	The gas composition values are read according to the DSfG rules in the cycle of analyses of the gas chromatograph or alternatively from the correlative gas measuring device.
Modbus	Modbus RTU via serial interface RS 232 or via Bus RS 485. Alternative Modbus IP via Ethernet with gas quality manager GQM (e.g. Siemens PCS 7 with special program). For activation of the Modbus IP, the parameter "I Communication J imported main gas composition via Modbus 52 GC via GQM" must be switched from no to yes.
RMG bus	Company protocol based on MODBUS. The PGC functions as master and the ERZ2000-NG as slave. Up to 32 slaves can receive gas composition data in parallel via broadcasting.
DZU	Protocol for ultrasonic flow meters

If the measurement transmitter should be operated with HART protocol, the operating mode must be set to "Measurement value = Source value" and a current input combined with HART function selected as source.

**Note**

**If the transmitter is operated as a transmitter, it must be ensured that the transmitter feed is switched on in the assigned menu of the current input.**

The menu for the data sources contains all technical measurement possibilities of an input, regardless of whether these signals are available for the selected transmitter (e.g. current signal or frequency signal analogous to the measurement variable).

## 3.2 DSfG bus

Familiarity with the normal DSfG documents is assumed in this manual. These documents for users are listed in the *appendix J.1.1 Literature for the DSfG bus* for additional reference material. The DSfG functionalities realized in the ERZ2000-NG are implemented according to these requirements, i.e. in accordance with G485.

The DSFG operation can be realized via 3 interfaces COM 3, COM 4 and COM 5 and then must be adjusted in menu **IB Serial interfaces** with coordinates **IB09 COM 3 operating mode**, **IB12 COM4 operating mode** and **IB21 COM 5 operating mode**.

### IB Serial interfaces

Access Line	Designation	Value	Unit	Variable	
B	1	Baud rate COM1	38400	baudC0	
B	2	B/P/S COM1	8N1	bpsC0	
B	3	COM1 operating mode	OFF	modeC0	
B	4	Baud rate COM2	115200	baudC1	
B	5	B/P/S COM2	7E1	bpsC1	
B	6	COM2 operating mode	Test	modeC1	
B	7	Baud rate COM3	19200	baudC3	
B	8	B/P/S COM3	7E1	bpsC3	
B	9	COM3 operating mode	OFF	modeC3	
B	10	Baud rate COM4	9600	baudC4	
B	11	B/P/S COM4	8E1	bpsC4	
B	12	COM4 operating mode	OFF	modeC4	
B	13	Baud rate Vo	2400	baudVO	
B	14	B/P/S Vo	7E1	bpsVO	
B	15	Vo operating mode	Vo	modeVO	
T	16	Timeout gas quality	60	min	gbhToMx
B	17	Register offset	0		regOffs
B	18	Modbus address	1		mbAdr
B	19	Baud rate COM5	38400		baudC5
B	20	B/P/S COM5	8N1		bpsC5
B	21	COM5 operating mode	Modem		modeC5
B	22	Modbusaddr. COM1	1		mbAdrC0
B	23	Modbusaddr. COM2	2		mbAdrC1
B	24	Modbusaddr. COM3	0		mbAdrC3
E *	25	Address FLOWSIC	1		sickAdr
B	27	Modbus project	EGT		mbProj
I	28	COM5 DSR		0	dsrC5
I	29	COM5 RING		0	ringC5
I	30	COM5 DCD		0	dcdC5
B	31	Baud rate COM6	38400		baudC6

Figure 104: Menu "IB Serial interfaces"

The following applies:

Setting in IB09 / IB12 / IB21 operating mode	Interface	Task
DSfG control station	IB09 COM 3	ERZ2000-NG is the <b>DSfG control station</b>
DSFG	IB12 COM 4	ERZ2000-NG is the <b>"normal" participant</b> on the bus ERZ2000-NG is the computing and/or registration instance
Modem	IB21 COM 5	ERZ2000-NG establishes a <b>DSfG station access</b> as a DFÜ unit An external modem should be connected to COM 5

47

The DSFG bus is connected via COM 4 for a "normal" user.

#### DSfG pin assignment:

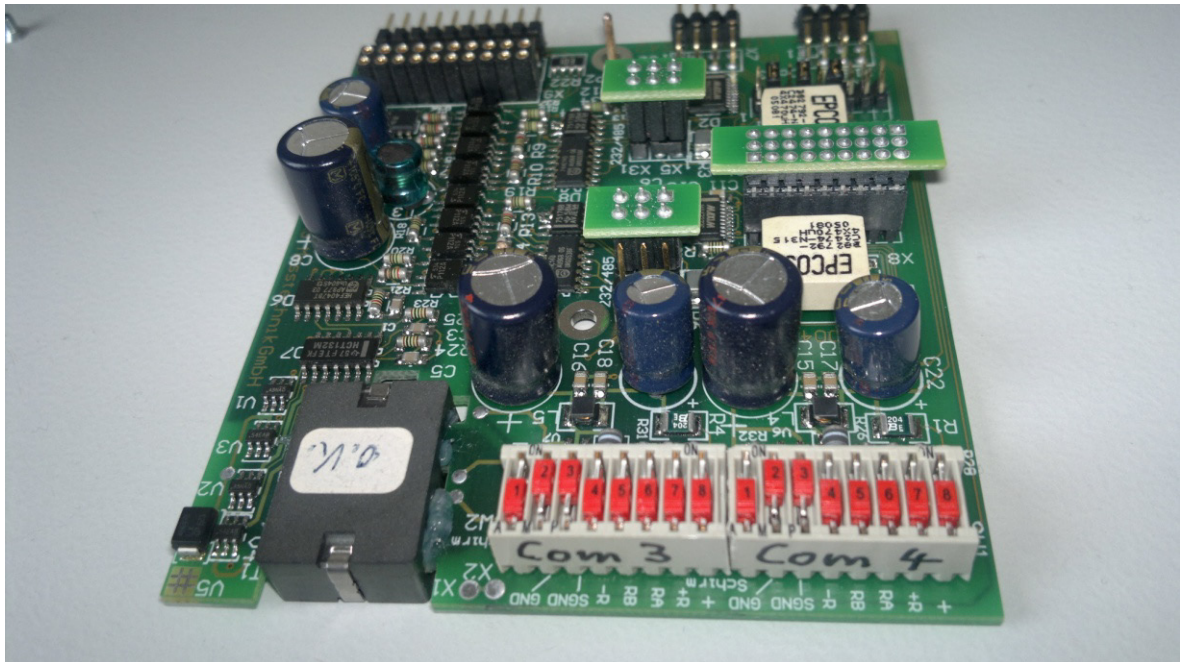
1	+U (+5V DC)	activatable via DIP Switch
2	GND	activatable via DIP Switch
3	RDA/TDA	
4		free
5	GND	activatable via DIP Switch
6		free
7	GND	activatable via DIP Switch
8	TDB/RDB	
9		free

GND and +5V are the voltage supply of the RS 485 part, not the computer. The housing of the trapezoidal plug must be connected electrically to the housing of the device.

#### DSfG bus termination

The start and end of the DSfG bus must be terminated electrically. For this purpose, there are two 8-pole DIP switches (*Figure 105*) on the DSfG interface board which are provided to switch the bus terminating resistors and current supply to the plug. The left switch on the board (see *Figure 105: DIL switches of COM 3 and COM 4*) is for the computing and registration instance, the right switch for the control station (if available). In *Figure 105*, the switches are "ON" in the "rear" status (towards the printed circuit diagram) and "OFF" in the "front" status.

The interfaces are isolated galvanically and conform to DSfG specifications. In order to fulfill the specifications for the bus supply and the idle level, the resistances and voltage can be activated with DIL Switches. The terminating resistor is positioned according to the specifications at the start or end of the main cable and, therefore, positioned externally on the cable or preferably on the star distributor.



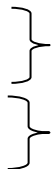
**Figure 105: DIL switches of COM 3 and COM 4**

If the function of the control station is also activated in a ERZ2000-NG, a cable must also be routed to the start distributor from the COM 3 interface, wherein the corresponding DIL switches must be set. There is a cutout in the cover plate of the computer which enables access to the DIL switch of the COM 4 interface. Since the control station is always a component of the computer and 2 cables must be connected in this case, it is functionally identical whether DIL 1 or 2 is used for activation.

**Meaning with switch closed:**

Closed means: the corresponding switch is set to "ON".

- 1 Device GND on the housing of the plug.
- 2 GND is connected to Pin 2 and 7 of the plug. **Standard = always ON**
- 3 GND is connected to Pin 5 of the plug. **Standard = always ON**
- 4 applies the 510 Ohm resistance to Pin 5 of the plug. GND idle level
- 5 applies the 510 Ohm resistance to Pin 8 of the plug. GND idle level
- 6 applies the 510 Ohm resistance to Pin 3 of the plug. Idle level 5 V
- 7 applies the 510 Ohm resistance to Pin 1 of the plug. Idle level 5 V
- 8 applies +5V to Pin 1 of the plug.



**Example of a standard setting in practice:**

Device fulfills the function control station on the DSfG bus: all switches to ON

Device not on an end of the DSfG bus: Switches 2 and 3 to ON

<b>⚠ Caution</b>
<b>The bus termination resistors must be activated externally at the star distributors or at the start and end of the main cable.</b>

An example of a comparison of two computers is provided in *annex .J.1.2 Cross-comparison via DSfG*

### 3.3 MODBUS

#### 3.3.1 Concept

<b>Note</b>
<b>There is an arbitrarily definable (configurable) range of 100 MODBUS registers in the ERZ2000-NG, the MODBUS super block</b>

There is a freely definable (configurable) range of 100 MODBUS registers in the ERZ2000-NG which can be pre-assigned with a factory setting (default) of 50 values of 4 bytes each. The contents of these 100 registers can be changed by the user at any time. This freely configurable range is called MODBUS super block. This Modbus super block is located in menu **II Modbus super block** (*Figure 106: Modbus super block*). All data in the super block is stored in successive register addresses with successive numbers. Therefore, quick data transmission is possible without individual queries. The super block can be assigned with an offset. In addition, there is a fixed range assigned with the most important data for the user. These registers cannot be changed by a configuration. The fixed range connects directly to the super block and shifts automatically with the offset.

**Change of data in the super block:**

Editing of the positions in the super block is simple; Modbus register 0 can be changed in menu **II Modbus super block** in coordinate **II01 MB reg. 0 = \*\*\*\***. The assignment of the register to a variable can be selected under "value". Clicking on [edit](#) opens an additional menu with the option of selecting all data in the device (floating point variables and measurements) as a Modbus register and assigning it to an address. In the same manner, the other registers can also be assigned variables.

### II Modbus superblock

Access Line	Designation	Value	Unit	Variable
B 1	MB reg. 0 = <a href="#">AC01</a>	<a href="#">Edit</a>	K	<a href="#">mbsb1</a>
B 2	MB reg. 2 = <a href="#">AB01</a>	<a href="#">Edit</a>	MPa	<a href="#">mbsb2</a>
B 3	MB reg. 4 = <a href="#">AE01</a>	<a href="#">Edit</a>	kg/m <sup>3</sup>	<a href="#">mbsb3</a>
B 4	MB reg. 6 = <a href="#">AE01</a>	<a href="#">Edit</a>	kg/m <sup>3</sup>	<a href="#">mbsb4</a>
B 5	MB reg. 8 = <a href="#">AD01</a>	<a href="#">Edit</a>	kWh/m <sup>3</sup>	<a href="#">mbsb5</a>
B 6	MB reg.10 = <a href="#">BB01</a>	<a href="#">Edit</a>	mole%	<a href="#">mbsb6</a>
B 7	MB reg.12 = <a href="#">BD01</a>	<a href="#">Edit</a>	mole%	<a href="#">mbsb7</a>
B 8	MB reg.14 = <a href="#">BC01</a>	<a href="#">Edit</a>	mole%	<a href="#">mbsb8</a>
B 9	MB reg.16 = <a href="#">HD01</a>	<a href="#">Edit</a>	m <sup>3</sup> /h	<a href="#">mbsb9</a>
B 10	MB reg.18 = <a href="#">HB01</a>	<a href="#">Edit</a>	kW	<a href="#">mbsb10</a>
B 11	MB reg.20 = <a href="#">HE01</a>	<a href="#">Edit</a>	m <sup>3</sup> /h	<a href="#">mbsb11</a>
B 12	MB reg.22 = <a href="#">HF01</a>	<a href="#">Edit</a>	m <sup>3</sup> /h	<a href="#">mbsb12</a>
B 13	MB reg.24 = <a href="#">GC04</a>	<a href="#">Edit</a>	%	<a href="#">mbsb13</a>
B 14	MB reg.26 = <a href="#">GC01</a>	<a href="#">Edit</a>	P/m <sup>3</sup>	<a href="#">mbsb14</a>

**Figure 106: Modbus super block**

Should the volume flow rate at measurement conditions be in the first position in the super block, proceed as follows:

View the MODBUS super block in the internet browser (*Figure 106: Modbus super block*). As a super user, you can search and select the coordinates. Then, go to the variable or edit and change the settings. Once the change settings have been loaded and the user clicks on "continue", the change is adopted. Once the calibration lock has been closed again, the newly entered measurement value is displayed.

Additional parameters for the MODBUS interface are found in *appendix J.2 Modbus*.

#### Note

The interface parameters for COM 1, 2 and 3 are adjusted in menu "IB Serial interfaces" in the coordinates for the respective interfaces. The Modbus interface can be operated in RTU or ASCII mode.

The Modbus address, register offset parameters and the super block definitions apply collectively for all 4 Modbus interfaces.



**IB Serial interfaces**

Access Line	Designation	Value	Unit Variable
B 1	Baud rate COM1	38400	baudC0
B 2	B/P/S COM1	8N1	bpsC0
B 3	COM1 operating mode	OFF	modeC0
B 4	Baud rate COM2	115200	baudC1
B 5	B/P/S COM2	7E1	
B 6	COM2 operating mode	Test	
B 7	Baud rate COM3	19200	
B 8	B/P/S COM3	7E1	
B 9	COM3 operating mode	OFF	
B 10	Baud rate COM4	9600	
B 11	B/P/S COM4	8E1	bpsC4
B 12	COM4 operating mode	OFF	modeC4
B 13	Baud rate Vo	2400	baudVO
B 14	B/P/S Vo	7E1	bpsVO
B 15	Vo operating mode	Vo	modeVO

OFF  
Test  
Modbus RTU  
Modbus ASCII  
IGM  
USE09  
USZ  
FLAWSIC600

**Figure 107: Serial interfaces**

Modbus is, depending on the version, available on COM 1 (RS 232, 422 or 485, depending on the hardware setting), on COM 2 (RS 232) and on COM 3 (RS 232 or 485). An additional Modbus interface is available as Modbus IP on jack RJ45, Ethernet TCP/IP.

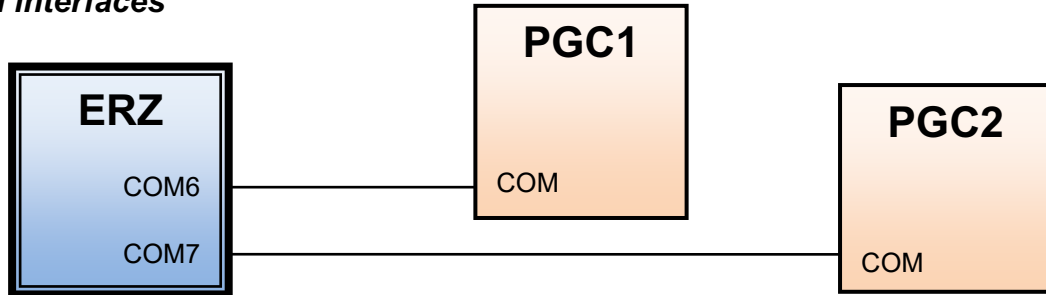
Special forms of the Modbus or parts of the settings are described in the appendix. The relates to the EGO Modbus (*appendix .J.2.2 Modbus EGO*), a special interface for Erdgas Ostschweiz, the Transgas Modbus (*appendix .J.2.3 Transgas Modbus*) and the EON Gas Transport Modbus (*appendix .J.2.4 Eon gas transport Modbus*), a Modbus for the Gascade company.

**3.3.2 Modbus master overview**

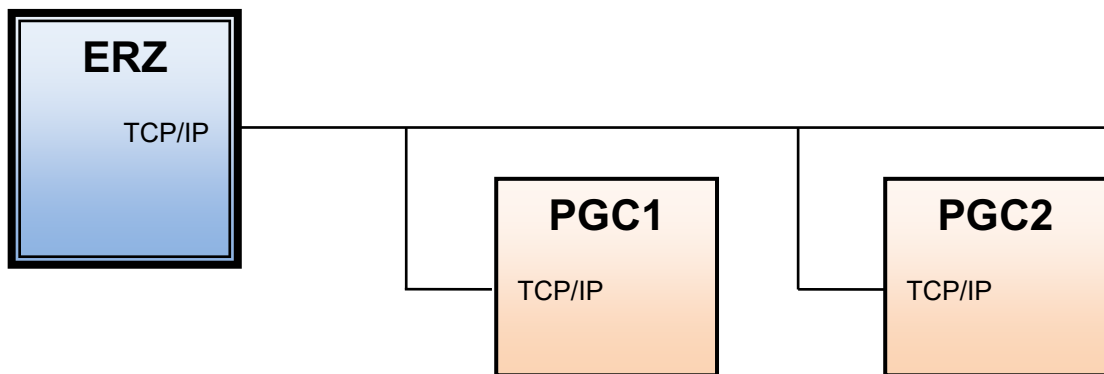
The ERZ2000-NG can receive the gas composition data from up to 2 process gas chromatographs (**Fehler! Verweisquelle konnte nicht gefunden werden.**). For this purpose, 2 Modbus masters have been implemented, which are listed in menus **IL** and **IM** (*Figure 110: IL Modbus master for the PGC (gas analysis)*). The PGCs operate as Modbus slaves. The participating devices can be *coupled* via:

152

**Serial interfaces**



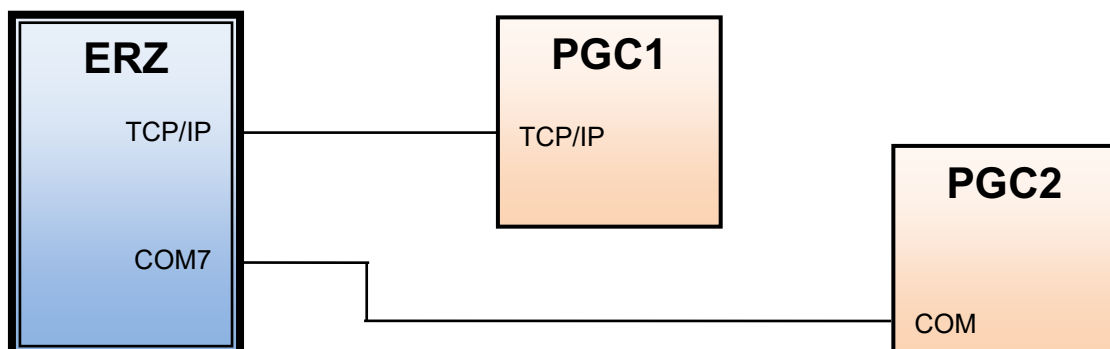
**TCP/IP network**



**Figure 108: Connection of PGCs (gas analysis)**

A **mixed constellation** can also be adjusted, which means one PGC is coupled via a serial interface and the other via a TCP/IP network (see *Figure 109: "Mixed" connection of PGCs (gas analysis)*).

**Serial interfaces and TCP/IP network**



**Figure 109: "Mixed" connection of PGCs (gas analysis)**

The Modbus master function is adjustable so that PGCs of other manufacturers can also be supported, e.g. a Siemens PGC.

Figure 110: IL Modbus master for the PGC (gas analysis) shows the Modbus menu for a PGC.

**IL Modbus Master GC1**

Access Line	Designation	Value	Unit	Variable	
E *	1	Sup.calorific val.	F7020	kWh/m3	exp1Ho
E *	2	Stand.density	F7024	kg/m3	exp1Rn
E *	3	Carbon dioxide	F8254	mole%	exp1CO2
E *	4	Hydrogen	F8284	mole%	exp1H2
E *	5	Nitrogen	F8250	mole%	exp1N2
E *	6	Methane	F8252	mole%	exp1Meth
E *	7	Ethane	F8256	mole%	exp1Eth
E *	8	Propane	F8258	mole%	exp1Prog
E *	9	N-butane	F8262	mole%	exp1NBut
E *	10	I-butane	F8260	mole%	exp1IBut
E *	11	N-pentane	F8266	mole%	exp1NPen
E *	12	I-pentane	F8266	mole%	exp1IPen
E *	13	Neo-pentane	F8264	mole%	exp1Neop
E *	14	Hexane/C6+	F8272	mole%	exp1Hexa
E *	15	Heptane/C7+	F8274	mole%	exp1Hept
E *	16	Octane/C8+	F8276	mole%	exp1Oct
E *	17	Nonane/C9+	F8278	mole%	exp1Non
E *	18	Decane/C10+	0	mole%	exp1Dec
E *	19	Hydrogen sulphide	0	mole%	exp1H2S
E *	20	Water	0	mole%	exp1H2O
E *	21	Helium	F8282	mole%	exp1He
E *	22	Oxygen	F8280	mole%	exp1O2
E *	23	Carbon monoxide	0	mole%	exp1CO
E *	24	Ethene	0	mole%	exp1Eten
E *	25	Propene	0	mole%	exp1Ppen
E *	26	Argon	F8286	mole%	exp1Arg
E *	27	Status	u1038==0		exp1Stat
B	28	Diagnosis 1	0		exp1Diag1
B	29	Diagnosis 2	0		exp1Diag2
D	30	Time stamp	DD-MM-YYYY hh:mm:ss		mb1_stamp
D	31	Analyze counter	0		mb1AnaCnt
D	32	Communication	waiting		mb1_ok
D	33	Data timeout	101478 s		mb1_datato
D	34	Sum components	0.0000	mole%	mb1KmpSum
D	35	Exception code	0		mb1ExcCod
D	36	Exception counter	0		mb1ExcCnt
E *	50	Operating mode	Modbus-IP		mb1_ifac
E *	51	IP-Address	160.221.45.24		mb1_ipAdr
E *	52	Modbus address	1		mb1_Adr

Figure 110: IL Modbus master for the PGC (gas analysis)

A reduced graphic (Figure 111: Reduced graphic: IL Modbus master for the PGC) which shows only the essential content of the right window presents the Modbus-specific data.

**IL Modbus Master GC1**

Access Line	Designation	Value	Unit	Variable
E *	1	Sup.calorific val.	F7020	kWh/m3 <a href="#">exp1Ho</a>
E *	2	Stand.density	F7024	kg/m3 <a href="#">exp1Rn</a>
E *	3	Carbon dioxide	F8254	mole% <a href="#">exp1CO2</a>
...				
E *	20	Water	0	mole% <a href="#">exp1H2O</a>
E *	21	Helium	F8282	mole% <a href="#">exp1He</a>
E *	22	Oxygen	F8280	mole% <a href="#">exp1O2</a>
E *	23	Carbon monoxide	0	mole% <a href="#">exp1CO</a>
E *	24	Ethene	0	mole% <a href="#">exp1Eten</a>
E *	25	Propene	0	mole% <a href="#">exp1Propn</a>
E *	26	Argon	F8286	mole% <a href="#">exp1Arg</a>
E *	27	Status	u1038==0	<a href="#">exp1Stat</a>
B	28	Diagnosis 1	0	<a href="#">exp1Diag1</a>
B	29	Diagnosis 2	0	<a href="#">exp1Diag2</a>
D	30	Time stamp	DD-MM-YYYY hh:mm:ss	<a href="#">mb1_stamp</a>
D	31	Analyze counter	0	<a href="#">mb1AnaCnt</a>
D	32	Communication	waiting	<a href="#">mb1_ok</a>
D	33	Data timeout	101478 s	<a href="#">mb1_datato</a>
D	34	Sum components	0.0000 mole%	<a href="#">mb1KmpSum</a>
D	35	Exception code	0	<a href="#">mb1ExcCod</a>
D	36	Exception counter	0	<a href="#">mb1ExcCnt</a>
E *	50	Operating mode	Modbus-IP	<a href="#">mb1_ifac</a>
E *	51	IP-Address	160.221.45.24	<a href="#">mb1_ipAdr</a>
E *	52	Modbus address	1	<a href="#">mb1_Adr</a>
E *	53	ModbusIP timeout	2000 ms	<a href="#">mb1time</a>
E *	54	Slave accepts gaps	No	<a href="#">mb1_loecher</a>
E *	55	Byteorder 16Bit Int	21	<a href="#">mb1_bo_u</a>
E *	56	Byteorder 32Bit Int	2143	<a href="#">mb1_bo_I</a>
E *	57	Byteorder float	2143	<a href="#">mb1_bo_F</a>
E *	58	Byteorder double	21436587	<a href="#">mb1_bo_D</a>
E *	59	Read function code	3	<a href="#">mb1_fc</a>
A *	70	actual selected	univ.Modb.Master 1	<a href="#">selUmbm</a>
A *	71	Position contact	OFF	<a href="#">ktkUmbm</a>
E *	72	Selection mode	Always Master 1	<a href="#">modUmbm</a>
E *	73	selected contact	OFF	<a href="#">kzoUmbm</a>
B	98	used button	?	<a href="#">exp1btn</a>

**Figure 111: Reduced graphic: IL Modbus master for the PGC**

A detailed description of the analysis-specific data IL01 to IL26 is provided in *chapter 6.6.4 IL Modbus Master*. The various selectable streams are also explained here.

**Register address**

The ERZ2000-NG has the default of the PGC register in the values of, e.g. **IL01 Calorific value**, wherein the desired value is found, e.g. **Register 7020** for the calorific value in coordinate **IL01**.

The ERZ2000-NG receives information from the data type about how the information coming from the PGC must be converted. **F 7020** means that the calorific values is delivered simply as an exact floating point number (float). The following data types are used:

- D:** Double exact floating point number (double float)
- F:** Single exact floating point number (double float)
- U:** 32-bit unsigned integer (long)
- u:** 16-bit unsigned integer (short)

155

An implemented formula evaluation enables division and use of parentheses in addition to multiplication and addition.

**Example unit conversion**

A value coming from the PGC can be converted using a factor. For instance, to convert the calorific value with the unit kWh/m<sup>3</sup> to MJ/M<sup>3</sup>, "F7020\*3.6" must be multiplied in coordinate **IL01**.

Access Line	Name	Value	Unit
E § 1	Calorific value	F7020*3.6	MJ/m <sup>3</sup>

**Example addition rules**

It is possible that there is no entry field available in the ERZ2000-NG for a gas component measured by the PGC, such as cyclo-pentane in register 8290. In this case, the cyclo-pentane can be added to the share of another component, e.g. neo-pentane. Then, the value "F8264+F8290" must be entered in coordinate **IL13**.

Value
F8264+F8290

**Example constants**

It is possible that components which are provided to the ERZ2000-NG by the PGC are not available, such as hydrogen sulphide. Therefore, they are zeroed as follows:

Value
0

**IL27 status**

For example, the following could be required for the PGC status:

- Value=1: The PGC measures without errors.
- Value=0: The PGC is in alarm.
- Value=0: The PGC is in revision.

**Note**

**Only with value 0 the values of the gas quality are transferred.**

It is possible that a PGC does **not** provide the status in exactly this form. Instead, it gives:

- Register 10: It shows the number of pending alarms. If the register shows the value 0, the PGC is alarm-free. This is a 16-bit integer register.
- Register 2: Information provided here is coded bit by bit. If the bit with the significance 4 is set, the PGC is in measurement mode. This is a 32-bit integer register.

The status formation can be formulated in coordinate **IL27** with the following considerations:

A 16-bit integer register must be read for the first part. The number of pending alarms that is readable there relates to the data type of an unsigned integer (unsigned short int). The prefix for this is a lower-case **u**. The register address is 10, i.e. the value with **u10** must be requested.

Then, the value must be checked with a comparison operator to zero. The expression for the first part is **u10==0**. As a result, the expression has the value true when **u10** contains the value **0**.

A 32-bit integer register must be read for the second part. Since this value must be interpreted bit by bit, it is an unsigned integer with 32 bits (unsigned long int). The prefix for this is a capital **U**. The register address is 2, i.e. the value with **U2** must be requested.

Then, it must still be determined whether the bit with significance **4** is set. For this purpose, the bit-by-bit **and** must be used as an operator, which is represented by the character **&**. The second partial expression then becomes **u2&4**. This expression has the value 0 as a result when the bit is not set with significance 4 and a value different than 0 when the bit is set. The bits with a different significance than 4 do not influence the result.

Finally, the two partial expressions must be linked by a logical And. This operator is represented by the characters **&&**. The parentheses rules must be ob-

served, i.e. parentheses must be used in both partial expressions. The complete expression for *IL27* is **(u10==0)&&(U2&4)**.

Access	Line	Name	Value	Unit
E §	27	Status	(u10==0)&&(U2&4)	

There are a total of 80 characters available for formulation of the expression.

157

Expressions can consist of

- **Arithmetic operators**
  - Addition +
  - Subtraction –
  - Multiplication \*
  - Division /
  - Modulo %
  - Algebraic sign -
- **Comparison operators**
  - greater than >
  - less than <
  - greater than or equal to >=
  - less than or equal to <=
  - equal ==
  - unequal !=
- **Logical operators**
  - Logical And &&
  - Logical Or ||
  - Not !
- **Bit-by-bit operators**
  - Bit-by-bit And &
  - Bit-by-bit Or |
  - Exclusive Or ^
  - Bit-by-bit negation ~
- **Condition**
  - a?b:c if a then b else c
- **Parentheses**
  - ()
- **Constants**
  - Integers, e.g. 42
  - Floating point numbers, e.g. 1.234
  - Exponential representation, e.g. 1.2345E-3
  - unsigned, the role of the algebraic sign is put into effect by the algebraic sign operator.

**IL30 Time stamp**

Shows the time of the last PGC answer.

**IL31 Analysis counter**

The counter shows the number of gas analyses conducted by the PGC.

**IL32 Communication**

Shows the current status of the data exchange with the PGC: "waiting", "At rest" or "Running".

**IL33 Data timeout**

Shows the time elapsed between the last PGC query and answer.

**IL35 Exception code**

Shows the Modbus error code.

**IL36 Exception Counter**

Shows the Modbus error counter.

**IL50 Operating mode**

This operating mode determines the type of Modbus coupling between ERZ2000-NG and PGC. The following adjustment options are available:

- "Off" No coupling is activated.
- "Modbus IP" Coupling via TCP/IP network
- "Modbus RTU C6" Serial coupling via Com interface C6
- "Modbus RTU C7" Serial coupling via Com interface C7

**IL51 IP address**

The PGC IP address must be entered here (is only necessary in network operation).

**IL52 Modbus address**

The Modbus address of the PGC must be entered here (is only necessary in serial operation).

**IL53 Modbus IP timeout**

The maximum time delay of the PGC answer must be entered here (only in network operation).

**IL54 Slave accepts gaps**

This operating mode determines the manner in which the ERZ2000-NG sends its queries to the PGC. The key here is how the PGC reacts when unassigned Modbus registers ("gaps") are queried. The following options are available:

- **No**  
The PGC sends an exception telegram when unassigned Modbus registers are queried. In this case, the ERZ2000-NG must send several individual queries.



- **Yes**

The PGC sends answer data and fills unassigned Modbus registers with "0" (zero). In this case, a signal query of the ERZ2000-NG is adequate.

**IL55 Byteorder 16-Bit Int**

The byte sequence of 16-bit integers can be adjusted here. A 16-bit value consists of two bytes, the lower-significance byte and the higher-significance byte. The following setting options are available:

→ 12 / 21

**IL56 Byte ord 32-Bit-Int**

The byte sequence of 32-bit integers can be adjusted here. A 32-bit value consists of four bytes. The following setting options are available:

→ 1234 / 2143 / 3412 / 4321

**IL57 Byte order float**

The byte sequence of single exact floating point numbers can be adjusted here. A single exact floating point number consists of four bytes. The following setting options are available:

→ 1234 / 2143 / 3412 / 4321

**IL58 Byte order double**

The byte sequence of double exact floating point numbers can be adjusted here. A double exact floating point number consists of eight bytes. The following setting options are available:

→ 12345678 / 21436587 / 34127856 / 43218765 / 56781234 / 65872143 / 78563412 / 87654321

**The following applies for coordinates IL55 to IL58:**

The numbers symbolize the significance. The significance of the byte increases with the numerical value. The sequence is read from left to right.

**IL70 Currently selected**

Shows the currently active Modbus master and thus the assigned PGC.

**IL71 Contact position**

Shows the current switching status of the selected control contact.

- **Off:** Contact is switched off.
- **On:** Contact is switched on.

**IL72 Selection mode**

This operating mode determines the manner in which the two Modbus masters work. The following options are available:

- **Always Master 1**

The ERZ2000-NG only works with a single PGC. Only Master 1 is active for querying of gas analysis data of the assigned PGC 1.

- **Always Master 2**

In this case, the ERZ2000-NG only works with a single PGC. Only Master 2 is active for querying of gas analysis data of the assigned PGC 2.

- **Contact**

The ERZ2000-NG can work with two PGCs. The selection of which of the two should be currently active takes place with a selectable input contact (see coordinate **IL73** for the source).

- **Better**

In this case, the ERZ2000-NG works with two PGCs. The selection of which of the two should be currently active is made by the ERZ2000-NG itself. The "better" PGC is taken, which means the one which operates most error-free.

### IL73 Source

The input contact which controls the cooperation of the ERZ2000-NG with the two PGCs is selected here. The following options are available:

- **Off:** No contact for PGC control is selected.
- **Contact input 1:** Contact input 1 controls the PGC selection.
- **Contact input 2:** Contact input 2 controls the PGC selection.
- **Contact input 3:** Contact input 3 controls the PGC selection.
- **Contact input 4:** Contact input 4 controls the PGC selection.
- **Contact input 5:** Contact input 5 controls the PGC selection.
- **Contact input 6:** Contact input 6 controls the PGC selection.
- **Contact input 7:** Contact input 7 controls the PGC selection.
- **Contact input 8:** Contact input 8 controls the PGC selection.

The RMG bus on the gas analysis data of a PGC (e.g. PGC9300) which is sent to one or multiple computers (ERZ2000-NG) is described in this chapter (*chapter 6 Parameter of the gas*).

### 3.4 NAMUR sensor adjustment (optional)

The integrated (**optional**) Ex isolation stage can be adjusted with a manual or predefined calibration to the HF scanning head with respect to the trigger threshold and switching hysteresis. This simple possibility at the push of a button replaces the relatively elaborate adjustment with potentiometers. The **GU Namur sensor adjustment** menu enables the following settings for NAMU signals of high or low-frequency transmitters or ENCO encoders, as well as pressure and temperature transmitters:

#### GU Namur Sensor adjustment

Access Line	Designation	Value	Unit Variable
E *	1 Sensor type A	standard Namur ▾	turbArt1
E *	2 Sensor type B	standard Namur ▾	turbArt2
S	3 Trig. RMG-tap	60	trigRmg
S	4 Hyst. RMG-tap	50	hystRmg
S	5 Trig. stnd. Namur	70	trigNam
S	6 Hyst. stnd. Namur	45	hystNam
E *	7 Trig. man. just.	60	trigAnd
E *	8 Hyst. man. just.	50	hystAnd

Enter Cancel Load defaults Refresh

Figure 112: Menu: GU Namur sensor calibration

Coordinates **GU01** and **GU02** offer 3 possibilities of carrying out the calibration:

"Standard NAMUR"	Standardized trigger threshold and hysteresis are loaded.
"RMG tap"	This is the factory setting. Special trigger threshold and hysteresis are loaded.
"Manual adjustment"	Trigger value and hysteresis can be finely and roughly adjusted.

## 3.5 Settings for communication

### 3.5.1 IA TCP/IP network

#### IA TCP/IP network

Access Line	Designation	Value	Unit	Variable
B	1	own IP-Addr.Eth1	10.20.13.73	<a href="#">my_ipE1</a>
I	12	MAC-address Eth1	00-05-51-05-1A-FC	<a href="#">macAddrE1</a>
B	13	Netmask Eth1	255.255.255.0	<a href="#">netmaskE1</a>
B	14	Gateway Eth1	10.20.13.1	<a href="#">gatewayE1</a>
B	15	DNS Eth1	172.17.248.98	<a href="#">namesrvE1</a>
B	16	DHCP Eth1	No <input type="button" value="v"/>	<a href="#">dhcpE1</a>
B	17	MTU Eth1	1500	<a href="#">mtuE1</a>
B	21	own IP-Addr-Eth2	160.221.45.110	<a href="#">my_ipE2</a>
D	24	GIA-countdown	0	s <a href="#">giaCntDwn</a>
S	32	MAC-address Eth2	00-00-00-00-00-00	<a href="#">macAddrE2</a>
B	33	Netmask Eth2	255.255.0.0	<a href="#">netmaskE2</a>
B	34	Gateway Eth2	192.168.20.254	<a href="#">gatewayE2</a>
B	35	DNS Eth2	194.25.0.70	<a href="#">namesrvE2</a>
B	36	DHCP Eth2	No <input type="button" value="v"/>	<a href="#">dhcpE2</a>
B	37	MTU Eth2	1500	<a href="#">mtuE2</a>
D	41	Port HTTP	80	<a href="#">httpdport</a>
E *	42	remote control	Yes <input type="button" value="v"/>	<a href="#">vncd</a>
E *	43	port remote control	4831	<a href="#">vncdport</a>

**Figure 113: Menu: IA TCP/IP network**

#### Adjustment of parameters

In order for the network connection to function correctly, the necessary settings must be made in menu **IA TCP/IP network**.

If "yes" is activated in coordinate **IA16 DHCP Eth1**, the network configuration is assigned automatically. Otherwise it must be entered manually. For example, the IP4 address for the ERZ2000-NG must be entered manually in coordinate **IA01 own IP-Addr. Eth1** for network 1, e.g. "10.20.13.71". Under this address (or the automatically assigned address), the ERZ2000-NG operates as an HTTP server and can be activated with a standard browser (Internet Explorer, Firefox) (see also *chapter 2.1.3 Remote control / parameterization*). In **IA32 MAC-address Eth2**, the MAC address Ethernet 2 can be entered by a super user.

Coordinate **IA15 DNS Eth1** (DNS = Domain Name Service) contains the IP address of the service for the name resolution. The setting is connected to the time service via network function.

The **IA17 MTU Eth1** coordinate can be used to set the maximum packet size of the transmission protocol (MTU). This may be necessary if there are connection problems (firewall, mobile radio, ..).

**Note**

Please only make these settings after consulting your IT department if there are connection problems (firewall, mobile phone, ...).

The analog assignments for the Ethernet interface 2 are made with coordinates **IA21, IA33, IA34, IA35 and IA36**.

The value of coordinate **IA41 Port HTTP** is typically Port 80. It cannot be changed.

### 3.5.2 IC DSfG instance computer

#### IC General DSfG

Access Line	Designation	Value	Unit	Variable
E *	1	Corrector address	OFF	myAdrU
E *	2	CRC12 start value	123	myCRC
D	3	Corrector entity	U2	myInstU
D	4	Time of last event	20-09-2018 11:48:03	TlEvent
D	5	Last event	-5612	lEvent
D	14	Own bit string	0000 hex	Bitleiste
E *	20	Meter address	OFF	myAdrE
D	21	Meter entity	F2	myInstE

Enter Cancel Load defaults Refresh

Figure 114: Menu: IC DSfG instance computer

The DSfG address of the computer instance (A, B, C, etc.) is identified in **IC01 Corrector address**. All 30 DSfG slave addresses are permitted here, as well as the setting "Off". The computer instance cannot be parameterized as a control station.

**Note**

Adjustment of the DSfG address of the computer and the totalizer instance is relevant for billing.

The computer instance uses the COM4 interface. The DSfG interface board must be installed in the ERZ2004. The COM4 **operating mode IB12** must be set to DSfG for the DSfG and bits/parity/stop bits **IB 11** must be set to "7E1". The values 9600, 19200, 38400, 57600 and 115200 are permissible as the baud rate setting.

### Note

**The following applies for the DSfG:**

**Take the lowest possible baud rate.**

**Due to the special design of the DSfG protocol, baud rates of 19200 or higher only have minimal speed increases, whereas the system load and susceptibility to interference increases significantly.**

Coordinate **IC05 Last event** documents the last event in the computer instance. The number code can be positive (message coming) or negative (message going). The number value stands for a message text. The message numbers 1...999 are universal messages. Higher numbers are assigned with manufacturer-specific messages. The range 5000...5999 was reserved and used for the ERZ2000-NG. For the meaning, refer to the documentation for DSfG events. The time stamp for the last event can be read under **IC04**.

**IC14** dedicate bit string contains the central status indicator for the DSfG.

Bit0	Collective alarm
Bit1	Fault Vo
Bit2	Fault P or den
Bit3	Fault T or st
Bit4	Min. warn. lim. Vo, P, T, den or st
Bit5	Min. alarm lim. Vo, P, T, den or st
Bit6	Max. warn. lim. Vo, P, T, den or st
Bit7	Max. alarm lim. Vo, P, T, Rb or st
Bit8	Low-significance bit direction
Bit9	revision
Bit10	Parameter change
Bit11	Calorific value fault
Bit12	Carbon dioxide fault
Bit13	Original totalizer fault
Bit14	Substitute GC
Bit15	High-significance bit direction

**Note**

The complete data element list of the computer instance of the ERZ2000-NG is included in the device-internal documentation: see: Documentation/II DSfG/1. Data elements/a Computer

### 3.5.3 ID DSfG entity recording

#### ID DSfG entity recording

Access Line	Designation	Value	Unit	Variable
B 1	Rec.entity address	OFF		<a href="#">myAdrR</a>
D 2	Recording entity		R2	<a href="#">myInstR</a>
B 3	Service request	999999999		<a href="#">serviceReq</a>
B 4	AG 16 visible	No		<a href="#">extVis</a>
B 5	Identifier AG1	AG1		<a href="#">aq1Name</a>
B 6	Identifier AG2	AG2		<a href="#">aq2Name</a>
B 7	Identifier AG3	AG3		<a href="#">aq3Name</a>
B 8	Identifier AG4	AG4		<a href="#">aq4Name</a>
B 9	Identifier AG5	AG5		<a href="#">aq5Name</a>
B 10	Identifier AG6	AG6		<a href="#">aq6Name</a>
B 11	Identifier AG7	AG7		<a href="#">aq7Name</a>
B 12	Identifier AG8	AG8		<a href="#">aq8Name</a>
B 13	Identifier AG9	AG9		<a href="#">aq9Name</a>
B 14	Identifier AG10	AG10		<a href="#">aq10Name</a>
B 15	Identifier AG11	AG11		<a href="#">aq11Name</a>
B 16	Identifier AG12	AG12		<a href="#">aq12Name</a>
B 17	Identifier AG13	AG13		<a href="#">aq13Name</a>
B 18	Identifier AG14	AG14		<a href="#">aq14Name</a>
B 19	Identifier AG15	AG15		<a href="#">aq15Name</a>
B 20	Identifier AG16	AG16		<a href="#">aq16Name</a>
Q 21	Attention freeze	No		<a href="#">freezAtt</a>
B 22	Archive headline	Designation		<a href="#">tsvHead</a>
B 23	AG 12 visible	No		<a href="#">gbhVis</a>

Enter   Cancel   Load defaults   Refresh

Figure 115: Menu: ID DSfG entity recording

**ID 01 Rec.entity address** contains the DSfG address of the registering unit. All 30 DSfG slave addresses are permitted here, as well as the setting "Off". The registration unit cannot be parameterized as a control station. The registration instance uses the COM4 interface. For further information, refer to **ID 01 Rec.entity address**.

The fill level indicators of the individual archive groups are checked to determine if the **ID 03 Service request** number value entered here has been exceeded. An fault message is issued if the value has been exceeded: **H56-4 Service request**, i.e. service personnel needed urgently.

**ID 04 AG 16 visible** controls whether archive group 16 (extra measurements) should be visible for the central unit.

Text for identification of the corresponding archive group can be entered in coordinates **ID 05** to **ID 12**.

A DSfG freeze telegram can be triggered with "yes" in **ID21 Attention freeze**. This may be necessary if there is no revision switch in a station without MRG.

Archive contents can be exported with TSV files. Coordinate **ID22** offers settings options for design of headers and/or column headings.

- DSfG:** The columns are overwritten with DSfG data element designations, e.g. *baae*.
- Name:** The columns are overwritten with plain text, e.g. *corrected volume at meas. cond. totalizer AM1*.

### Note

The complete data element list of the registration instance of the ERZ2000-NG is included in the device-internal documentation: see: Documentation/II DSfG/1. Data element/b registration.



### 3.5.4 IE Remote data transmission access

#### IE Remote data transmission access

Access Line	Designation	Value	Unit	Variable
B 1	RDT address modem	OFF ▾		<a href="#">myAdrD</a>
D 2	RDT entity		D2	<a href="#">myInstD</a>
D 3	State of modem	Waiting for modem		<a href="#">modemState</a>
B 4	Bus identification	000000000000		<a href="#">buskennung</a>
B 5	RDT ID	1111111111111111		<a href="#">dfueId</a>
B 6	Modem init. string	ate0s0=1		<a href="#">mdmInitStr</a>
B 7	Dial prefix	atx3dt0		<a href="#">dialPrefix</a>
D 10	Time RDT param.	DD-MM-YYYY hh:mm:ss		<a href="#">dfuParChg</a>
B 13	Carrier message	Suppress ▾		<a href="#">anrufMsg</a>
B 14	PTB-Message	Suppress ▾		<a href="#">ptbZMsg</a>
D 15	DSfG-B-IP state		listen	<a href="#">dsfgbState</a>
D 16	DSfG-B-IP port		8000	<a href="#">dsfgbPort</a>
B 17	Network interface	ETH1 ▾		<a href="#">dsfgbBind</a>
B 18	RDT address IP	OFF ▾		<a href="#">myAdrI</a>
B 19	entity filter IP	ABC		<a href="#">exListe</a>

Enter Cancel Load defaults Refresh

Figure 116: Menu: IE DSfG DFÜ

Coordinate **IE01 RDT address modem** contains the DSfG address of the DFÜ unit. All 30 DSfG slave addresses are permitted here, as well as the setting "Off". The DFÜ unit CANNOT be parameterized as a control station. The DFÜ unit uses the COM4 interface. For further information, refer to **IC01 Corrector address**.

**Note**

**Adjustment of the addresses of the DFÜ instance of the computer and the totalizer instance is not relevant for billing.**

In general, the DFÜ is an independent device which simultaneously fulfills the function of control station. This cannot be adjusted in the ERZ2000-NG. The reason is that two different data protocols cannot run on an interface at the same time. (The control station algorithm basically differs from a slave algorithm). In order to avoid putting the stability of the DSfG bus at risk, an instance-free DSfG control station was implemented on COM 3 **IB09**. This runs completely independently without cross-connection to other instances of the ERZ2000-NG.

**IE03 State of modem** shows the current status of the modem.

stopped	Emergency Off status if control of the modem status machine is lost. This ensures that a potentially open telephone connection is disconnected and no further telephone activity takes place until the restart of the ERZ2000-NG.
Initialization	The modem initialization string <b>IE06</b> is sent. Then, a reaction is expected from the modem.
Waiting for modem	After initialization, the reaction of the modem is awaited. If it is positive, the modem is ready. If the reaction is negative or there is no reaction, the initialization is repeated. If there is still no reaction, with DSfG-DFÜ activated ( <b>IE01</b> ≠ "Off") message H48-1 Def.modem is sent or switched off.
Acknowledgment	Intermediate step: recognized syntactically correct acknowledgment from modem.
Modem ready	The initialization was successful. It reacts to incoming calls and edits triggers for outgoing calls.
PTB Time service	The trigger for handling the PTB time service is edited. The following messages are possible: <ul style="list-style-type: none"> <li>- <b>M52-2 Call</b> modem carrier signal coming</li> <li>- <b>M52-3 PTB time</b> PTB telephone time service Time recognized coming (when PTB time service was recognized) Old time, new time (when time adjustment was necessary) Messages carry the time stamp before or after successful adjustment.</li> <li>- <b>M52-3 PTB time</b> PTB telephone time service time recognized going</li> <li>- <b>M52-2 Call</b> modem carrier signal going</li> </ul>
Recognition	The query of bus recognition <b>IE04</b> is expected. This is Phase 1 of the login procedure.
Identification	Identification of the <b>IE05</b> is expected. This is Phase 2 of the login procedure.
Commands	The <b>IE05</b> identification is successful. Commands are expected. This is Phase 3 of the login procedure.
Connected	The command for transparent connection was recognized. The connection between remote center and local DSfG bus has been established. This is Phase 4 of the login procedure.
Hang up	The telephone connection is disconnected.

ERZ2000-NG wiring to modem. All 9 wires must be connected 1:1. All other variants are unsuitable.

**IE04 Bus identification** is Step 1 of the login procedure via modem (K-command). According to DSfG specifications, the bus identification must be exactly 12 characters long. The bus identification can also be changed via modem.

**IE05 RTD ID** is Step 2 of the login procedure via modem (K-command). According to DSfG specifications, the identification must be exactly 16 characters long. The identification can also be changed via modem.

169

The **IE 06 Modem init-string** is provided for initialization of the modem. The meaning of the command is explained in the documentation of the respective modem. The specification value "ate0s0=1" corresponds to the minimum requirement for the ERZ2000-NG to work with the modem.

Meaning of the specification value:

- at: Hayes command prefix (prerequisite for each command)
- e0: ECHO OFF: the modem should not repeat the received characters.
- s0=1: Automatic call acceptance after a ring character

In order to make a call, the command **IE07 Dial prefix** is required. The meaning of the commands is explained in the documentation of the respective modem.

- Minimum necessary information to be determined
- Is pulse dial necessary? (Brrr tatatatata), ATDP command
- Is multi-frequency dial necessary? (Pi Pa Pö Pa Pa Pö), ATDT commando
- Is there a dialing tone immediately?
- Are you on a private branch exchange? If so, private branch interpretation must be deactivated. See ATX command for this purpose.
- How do you receive a dialing tone in private branch exchanges? (e.g. dial zero first)

Frequently used dial commands:

- atx3dp: Dial command for pulse dial without identification of the private branch exchange.
- atx3dt: Dial command for multi-frequency dial without identification of the private branch exchange.
- atx3dt0: Dial command for multi-frequency dial without identification of the private branch exchange.  
With repeat dial when a zero is dialed first.

If a DFÜ parameter is changed in the command phase (Phase 3 of the login procedure) from the center, a time stamp **IE10 time RTD param.** is recorded. The **IE13 Carrier message** controls the activity of the message **M52-2 Call** (carrier signal modem). If the message is perceived as disturbing, it can be switched off here. **IE14 PTB message.** controls the activity of the message **M52-3 PTB time** (PTB telephone

time service time recognized). If the message is perceived as disturbing, it can be switched off here.

**IE15 DSfG-B-IP state** shows the statuses of the DSfG-B-IP machine.

170

opening	Opens a TCP-IP socket
listening	TCP-IP socket is in LISTEN status (waiting for a partner to dock).
Recognition	A partner has docked. Level 1 of the login procedure.
Identification	Level 2 of the login procedure.
Commands	Level 3 of the login procedure.
Connected	Transparent status
closing	TCP-IP connection is capped on the ERZ side
closed	TCP-IP connection is capped on both sides

The port specification for the DSfG-B-IP interface is in coordinate **IE16 DSfG-B-IP port**.

**Note**

The complete data element list of the data remote transmission instance of the ERZ2000-NG is included in the device-internal documentation: see: Documentation/II DSfG/1. Data elements/c Data remote transmission.

**3.5.5 IF DSfG master**

**IE DSfG master**

Access	Line	Designation	Value	Unit	Variable
D	1	DSfG device			<a href="#">dsfgAdrList</a>
S	2	General polling	traditional		<a href="#">pollMod</a>
S	3	double EOT	Yes		<a href="#">eot2</a>
S	4	Polling time	7.0	ms	<a href="#">leitDelay</a>
S	5	polling mode	fix		<a href="#">delayMod</a>
I	6	DSfG fault	0000	hex	<a href="#">dsfgActErr</a>
I	7	User pattern	00000000	hex	<a href="#">teilnehmer</a>
D	8	Address pattern	00000000	hex	<a href="#">dsfgAdrPatt</a>
I	9	Baud rate gross	0	bit/s	<a href="#">effBaud</a>
I	10	Baud rate net	0	bit/s	<a href="#">effNutz</a>
D	11	Working load	0.00	%	<a href="#">dsfglast</a>

Refresh

**Figure 117: Menu: IE DSfG master**

The addresses of all participants on the DSfG bus are listed in coordinate **IF01 DSfG device**. The following applies:

Capital letters = external addresses

Lower-case letters = internal addresses

Participants found on the bus are displayed here even if the control station is not active.

The strategy for the general polling is defined in **IF02 General polling** for an active control station.

traditional	General polling of all possible participants takes place 1 x per minute
Floating	General polling does not take place. Instead, all addresses are polled in rotation for any participants that have not been found yet. As a result, new or lost participants on the DSfG bus are found somewhat more quickly.
mixture	Combination of both of the above strategies.

The control station runs on COM3. Ensure the same setting in baud rate, data bits, parity and stop bits in regard to COM4 (DSfG slave instances)

With traditional control stations, 2 EOTs are sent, which can be adjusted in coordinate **IF03 Double EOT**. The second EOT is syntactically unnecessary. By omitting the second EOT, a speed increase of 20% is achieved in the polling without increasing susceptibility to interference or the system load of the bus.

**Note**

**It should be checked in the individual case whether external devices still function stably when the second EOT is omitted.**

The wait time between two polling processes is typically 7 msec. By reducing this time in coordinate **IF04 Polling time**, the polling speed is increased drastically. However, the system load on the DSfG slaves increases considerably.

**Note**

**It should be checked in the individual case whether external devices still function stably when the polling wait time is decreased.**

Coordinate **IF06 DSfG fault** is an auxiliary quantity for the information transport of the lower DSfG protocol layers for fault evaluation. If parameter **JD01 Software debug** is set to "yes", the following messages are activated:

- H64-6 DSfG unex char.: unexpected characters in telegram
- H64-7 DSfG overflow: Input buffer overflow
- H64-8 DSfG checksum: Block check incorrect
- H64-9 DSfG broadcast: Block check in broadcast incorrect
- H65-0 DSfG broadc\_inc.: Broadcast ignored
- H65-1 DSfG busterM,m.: Bus termination problem

### Note

**The cause of the messages may lie in the device in question or another bus participant. The device that displays the message does not necessarily have to be the cause.**

Coordinates **IF07 User pattern** and **IF08 Address pattern** are auxiliary quantities for the bit pattern; each bit corresponds to an external (**IF07**) or internal (**IF08**) participant. The least significant bit is DSfG address "A". Together with **IF06**, **IF01** is formed.

## 4 Transmitters

Various transmitters can be connected to the ERZ2000-NG. There are pre-settings for some of these transmitters which often do not require any adjustment or very little at all. By contrast, additional settings are required for other transmitters. The ordinary connection options and parameterization are presented.

The various transmitters are sorted below according to function. The gas component analysis and various flow meters have a separate chapter due to their importance. Some of the measurements are assigned to these chapters.

### Note

**Should custody-transfer parameters be changed, the calibration seal must be removed and the input switch must be switched to the "input" position.**

**Once the first parameter has been changed, it is written to the log book together with the entry "Calibration lock open +".**

**The flow computer immediately stops conversion and will not deliver current measurements until the input switch has been switched back to the "operation" position.**

## 4.1 Measurements

The measurements are listed in menu **A Measurements**. The first sub-item **AA Overview** displays some of these values in the live browser.

174

Designation	Value	Unit	Column	Jump target
Pa	0.55000	MPa	AB	<a href="#">Absolute pressure</a>
T	293.15	K	AC	<a href="#">Gas temperature</a>
Hs	9.188	kWh/m <sup>3</sup>	AD	<a href="#">Sup.calorific val.</a>
sd	0.75651	kg/m <sup>3</sup>	AE	<a href="#">Standard density</a>
rd	0.5549		AF	<a href="#">Relative density</a>
CO <sub>2</sub>	0.9960	mole%	BB	<a href="#">Carbon dioxide</a>
H <sub>2</sub>	1.0000	mole%	BC	<a href="#">Hydrogen</a>
N <sub>2</sub>	0.2988	mole%	BD	<a href="#">Nitrogen</a>
den	35.000	kg/m <sup>3</sup>	AG	<a href="#">Density</a>
Tden	10.00	°C	AH	<a href="#">Dens.transd.temp.</a>
Tvos	10.00	°C	AI	<a href="#">VOS temperature</a>
Vsm	431.1	m/s	AJ	<a href="#">Vel. of sound(M)</a>
Vsb	431.1	m/s	AK	<a href="#">Vel. of sound(B)</a>
Eta	12.0000	uPas	AM	<a href="#">Viscosity</a>
Kp	1.35400		AN	<a href="#">Isentrop. exponent</a>

**Figure 118: Overview of measurements**

After clicking on **AA Overview**, the screen shown in *Figure 118: Overview of measurements* appears. The heading of the sub-menu is under these lines, e.g.

### AA Measurements function key

Various measurements are displayed there, such a p (absolute pressure), T (gas temperature), etc.

If you click on this **Heading**, a menu with further explanations for the values on the previous screen appears (*Figure 119: Explanation menu*).



### AA Measured values function key

---

AA01    Overview Anchor 1

---

ID: o\_m01

---

[Display value for secondary applications](#)  
[X-Ref](#)

---

Data type [Panel](#)  
[X-Ref](#)

---

Unit of object

---

Format of object

---

Visible: [dausw](#)  
[X-Ref](#)

---

AA02    Overview Anchor 2

---

ID: o\_m02

---

[Display value for secondary applications](#)  
[X-Ref](#)

---

Data type [Panel](#)  
[X-Ref](#)

---

Unit of object

---

Format of object

---

Visible: [dausw](#)  
[X-Ref](#)

---

**Figure 119: Explanation menu**

Windows in which additional, in-depth definitions and / or explanations of the selected parameter are shown are opened by clicking on the underlined text.

Clicking on the Heading again will bring you back to the initial menu (*Figure 118: Overview of measurements*).

The corresponding live values, their unit (if available) are behind the measurements and the corresponding coordinates are in the menu and the jump target.

e.g.

## AA Measured values function key

Designation	Value	Unit	Column	Jump target
Pa	0.55000	MPa	AB	<a href="#">Absolute pressure</a>
T	293.15	K	AC	<a href="#">Gas temperature</a>
Hs	9.188	kWh/m <sup>3</sup>	AD	<a href="#">Sup.calorific val.</a>
sd	0.75651	kg/m <sup>3</sup>	AE	<a href="#">Standard density</a>
rd	0.5549		AF	<a href="#">Relative density</a>
CO <sub>2</sub>	0.9960	mole%	BB	<a href="#">Carbon dioxide</a>
H <sub>2</sub>	1.0000	mole%	BC	<a href="#">Hydrogen</a>
N <sub>2</sub>	0.2988	mole%	BD	<a href="#">Nitrogen</a>
den	35.000	kg/m <sup>3</sup>	AG	<a href="#">Density</a>
Tden	10.00	°C	AH	<a href="#">Dens. transp. temp.</a>

Figure 120: Listing of measurements

By clicking on the parameter under the jump target, the corresponding menu appears; e.g. clicking on the absolute pressure opens sub-menu **AB absolute pressure** (Figure 121: Menu AB Absolute pressure).

### Note

With super user access, measurements such as pressure ("AB04"), temperature ("AC04"), calorific value ("AD04"), etc. can be switched to a different unit, but without automatic conversion taking place.

Unlike the meters, the min. value / max. value assignment determines the calculation of the physical variable from the input value. Therefore, the change of the unit is purely a text change.

## 4.2 Pressure transducer

The various adjustment options for absolute pressure are listed based on the example of absolute pressure. Only the relevant part is shown in the right part of the browser in order to provide a better overview.

**AB Absolute pressure**

Access Line	Designation	Value	Unit	Variable
A *	1 Measured value	0.55000	MPa	drka
A *	2 Input value -> AB05	0.55000	MPa	drkaQll
E *	3 Operating mode	Default		drkaMod
G *	4 Unit	MPa		drkaDim
B	5 Default	0.55000	MPa	drkaVg
B	6 Lower warning limit	0.10000	MPa	drkaWGwu
B	7 Upper warning limit	1.00000	MPa	drkaWGwo
E *	8 Lower alarm limit	0.10000	MPa	drkaAGwu
E *	9 Upper alarm limit	1.00000	MPa	drkaAGwo
E *	10 Coefficient 0	0		drkaK0
E *	11 Coefficient 1	0		drkaK1
E *	12 Coefficient 2	0		drkaK2
E *	13 Coefficient 3	0		drkaK3
E *	19 Source	OFF		drkaInp
E *	21 Correction value	0.30000	MPa	drkaKorr
E *	22 Max. gradient	10	MPa/s	drkaMGdt
D	24 Base value	0.55000	MPa	drkaOrg
D	25 Mean for DSFG	0.55000	MPa	drkaEmiw
D	27 Current status	Fixed value		drkaCEstt
D	28 DSFG status	Fixed value		drkaEstt
D	29 Used range	0.89986	MPa	drkaMb
G *	30 Format	% .5f		drkaFrm
D	31 Min. drag indicator	0.10000	MPa	drkaMn
D	32 Max. drag indicator	0.99986	MPa	drkaMx
D	33 Current gradient	0.00000	MPa/s	drkaGdt
D	34 Second mean	0.55000	MPa	drkaSmiw
D	35 Minute mean	0.55000	MPa	drkaMmiw
D	36 Hourly mean	0.55000	MPa	drkaHmiw
D	37 Ongoing mean	0.55000	MPa	drkaCEmiw
D	38 Standard deviation	0.00000	MPa	drkaStAb
D	47 Revision mean	0.55000	MPa	drkaRmiw
D	48 retain value	0.55000	MPa	drkaLW
D	49 Daily mean	0.54914	MPa	drkaTmiw
E *	50 Manufacturer	ROSEMOUNT		drkaManuf
E *	51 Device type	3051S1CA2		drkaGerTp
E *	52 Serial number	0		drkaSeriNr
F	61 Measured value	0.55000	MPa	drka
F	62 Input value	0.55	MPa	drkaQll

Enter Cancel 3051SCA 10 bar Refresh

3051SCA 10 bar	3051CA2 5 bar	Cerabar S PMP 71 10 bar
3051SCA 55 bar	3051CA2 10 bar	Cerabar S PMP 71 50 bar
3051SCA 100 bar	3051CA3 15 bar	Cerabar S PMP 71 100 bar
3051SCA 120 bar	3051CA3 20 bar	STA800 35 bar
3051STA 10 bar	3051CA3 35 bar	STA800 100 bar
3051STA 55 bar	3051CA3 55 bar	2088A 2 bar
3051STA 100 bar	3051CA4 60 bar	2088A 3,6 bar
3051SCG 100 bar	3051CA4 80 bar	2088A 8 bar
3051STG 55 bar	3051CA4 100 bar	2088A 12 bar
3051STG 100 bar	3051CA4 275 bar	2088A 20 bar
	APC-2000 ALW 7 bar	2088A 55 bar
	APC-2000 ALW 20 bar	
	APC-2000 ALW 100 bar	

**Figure 121: Menu AB Absolute pressure**

The list of selectable pressure sensors is displayed in 3 columns instead of 1 central column.

The lower part provides a pre-selection of various pressure transducers approved for custody transfer applications, which can be selected. If you select one of these pressure transducers (e.g. "3051S1CA2 10 bar"), a pre-setting is applied, wherein the key data is already transferred. All data that is recommended has a bright yellow-green background.

178

This can be seen in *Figure 122: Pre-selection of a pressure transmitter* with an abbreviated representation of *Figure 121: Menu AB Absolute pressure*.

D	49	Tagesmittelwert	0,00000 MPa	<a href="#">drkaTmiw</a>
E #	50	Hersteller	ROSEMOUNT	<a href="#">drkaManuf</a>
E #	51	Gerätetyp	3051S1CA2	<a href="#">drkaGerTp</a>
E #	52	Seriennummer	0	<a href="#">drkaSerNr</a>
F	61	Messgröße	0,00000 MPa	<a href="#">drka</a>

**Figure 122: Pre-selection of a pressure transmitter**

With "enter" (below the table to the left, see *Figure 121: Menu AB Absolute pressure*), these values are specified in the ERZ2000-NG. The manufacturer and transmitter type and pressure range are adopted. The operating mode is defined with the transmitter type (in this case, measurement value = source value), the default value, the alarm and warning limits are pre-adjusted, transfer via Hart protocol is the pre-setting here. As an additional pre-setting, a current input combined with HART function is selected as source.

### Note

**If the transmitter is operated as a transmitter, it must be ensured that the transmitter feed is switched on in the assigned menu of the current input.**

### Note

**Please check these pre-settings!**

**They must also be adapted to your application as necessary.**

**Please fill in the missing data as necessary, such as the serial number of the transmitter, etc. This type plate data of the transmitters must always be entered at the end of the function block with the transmitter data.**

**Not all missing specifications are required.**

The manufacturer, serial number, etc. data will then appear automatically in the type plate display. Missing data can be written directly into the white fields. If you are not conducting official custody-transfer measurements, you can also connect other pressure transmitters.

**Note**

**In this case, select a transmitter from the list that is "most similar" and then adjust the values.**

If you want to change the values of the pre-settings, simply write in the white fields.

Further information about the variables can be obtained by clicking on the underlined parameters under variables. A possible adjustment range is also displayed, for example: Variable for **AB03 Operating mode**: [drkaMod](#)

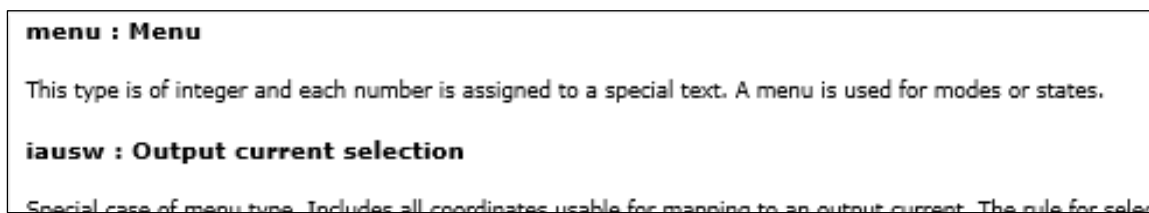
AB03 Absolute pressure Operating mode	Absolute pressure, operating mode
ID: drkaMod	
<u>Parameter protected by calibration lock</u> <u>X-Ref</u>	
Data type <u>Menu</u> <u>X-Ref</u>	
<ul style="list-style-type: none"> <li>• OFF</li> <li>• Default</li> <li>• From gauge press.</li> <li>• Meas.v.=source v.</li> <li>• Polynom. 1st order</li> <li>• Polynom. 2nd order</li> <li>• Polynom. 3rd order</li> <li>• 4-20mA coeff.</li> <li>• 0-20mA coeff.</li> <li>• 4-20mA lim.</li> <li>• 0-20mA lim.</li> <li>• P-USZ</li> <li>• Random</li> <li>• Sinus</li> <li>• Jump</li> </ul>	
Unit none	
Format Discrete texts	
Default 4-20mA lim.	
DSFG: 1 E bcdaa	
Modbus: 10002	
AB04 Absolute pressure Unit	Absolute pressure, selection of unit
ID: drkaDim	

**Figure 123: Operating mode selection range**

A 4..20 mA operating mode could also be selected for the chosen transmitter, then additional settings are necessary (definition of the measuring range, correction of characteristic curve, etc.).

Other adjustment options can be selected for other transmitters with different transmitters. For testing purpose Random provides a stoichiometric signal, Sine a sinusoidal shape and Jump a jump of the measurement.

Clicking on the underlined parameters provides further, in-depth information about the parameter, e.g. "[Menu](#)":



**Figure 124: "Menu" terminology explanation**

There are additional parameters back in menu **AB Absolute pressure** (Figure 121: *Menu AB Absolute pressure*).

If the operating mode is set to "Off", no measurement takes place and the input is switched off. With Default, no measurement takes place, but a fixed value is used for additional calculations.

Resistance measurements on PT100, PT500 and PT1000 can be also be conducted for the gas temperature measurement (next chapter). The characteristic curve of these resistance measurements as a function of the temperature is not exactly linear, and can be described by a polynomial with 4 coefficients (0, 1, 2, 3). Then the corresponding coefficients can be entered.

If the operating mode "0/4-20 mA limit value" is selected, the limit ranges automatically define the alarm limits. This does not apply with the setting "4-20 mA coeff." for the operating mode. With the 4-20 mA coefficient setting, it is not the calibrated range that defines the alarm limits, rather the value of "Coefficient 0" is set for the 0/4 mA value and the value of "Coefficient 1" is set for the 20 mA value. Then, the alarm limits are freely adjustable and have no effect on the representation of the current input.

The DZU protocol is also frequently selected for digital transfer for pressure and temperature.

The unit for pressure can be selected as bar, kp/cm<sup>2</sup>, psi, MPa, atm, kPa, torr, bara, Pa and hPa.

The default value is used when the measurement runs beyond of the alarm limits.

The input to which the signal is connected is assigned in the selection field for the "Source". The setting for whether the signal is connected as 4..20 mA or Hard should also be made here.

The correction value causes an offset shift. It is calculated from: Reference value minus display value and is entered directly in the unit of the pressure. Example:

181

value read on the reference device	=	20.00 bar,
value displayed on the ERZ2000-NG	=	20.02 bar,
result		-0,02 bar

This value must be entered in line 21 (*Figure 121: Menu AB Absolute pressure*) with the correct algebraic sign.

The base value is the uncorrected measurement (before offset correction with the value **AB21**).

The format of the pressure value can be changed in super user mode. If "%.5f" is shown in the display, the "5" indicates the number of decimal places. You can change this as desire in the scope of the available values. For example, the number "12.345" is displayed as:

with "%.0f" as 12  
 with "%.1f" as 12.3  
 with "%.2f" as 12.35

the rounding of the third decimal place is factored in correctly here.

The calculations generally take place with 8 digits, wherein the 8th digit is subject to rounding errors. Therefore, 7 digits are relevant, regardless of whether they are before or after the decimal separator. For example, with 5 digits before the decimal separator, having 3 or more digits after the decimal separator does not make sense. Adjust the number of digits on the sensors, if necessary.

More digits give you a false impression of accuracy that is not provided!

The internal calculations are always conducted internally with the maximum possible accuracy, regardless of the selection of digits. If a measurement, e.g. pressure, has more than 7 digits before the decimal separator, the selected unit is unfavorable. In this case, the recommendation would be, for example, to use "MPa" instead of "Pa".

Data displayed as average values is presented below. The revision mean value is used for the DSfG revision.

The blue fields contain the freeze values, but the time of the resolution must be considered here.

Menu **OB Overpressure** shows the same display as **AB Absolute pressure**. This function is required if an overpressure transducer is used instead of the absolute pressure transducer. Then, the operating mode must be set to "from overpressure" in **AB Absolute pressure**.

**OB Gauge pressure**

Access Line	Designation	Value	Unit	Variable
A *	1 Measured value	42.000	bar	drku
A *	2 Input value -> OB05	42.000	bar	drkuQll
E *	3 Operating mode	OFF		drkuMod
G *	4 Unit	bar		drkuDim
B	5 Default	42.000	bar	drkuVg
B	6 Lower warning limit	14.000	bar	drkuWGwu
B	7 Upper warning limit	70.000	bar	drkuWGwo
E *	8 Lower alarm limit	14.000	bar	drkuAGwu
E *	9 Upper alarm limit	70.000	bar	drkuAGwo
E *	11 Coefficient 0	0		drkuK0
E *	12 Coefficient 1	0		drkuK1
E *	13 Coefficient 2	0		drkuK2
E *	14 Coefficient 3	0		drkuK3
B	15 Ambient pressure	1.01325	bar	pAmb
E *	16 Source	OFF		drkuInp
E *	17 Correction value	0.000	bar	drkuKorr
E *	19 Max. gradient	10	bar/s	drkuMGdt
D	21 Base value	42.000	bar	drkuOrg
D	22 Mean for DSFG	42.000	bar	drkuEmiw
D	27 Current status	Stop		drkuCEstt
D	28 DSFG status	Stop		drkuEstt
D	29 Used range	0.000	bar	drkuMb
G *	30 Format	% .3f		drkuFrm
D	31 Min. drag indicator	42.000	bar	drkuMn
D	32 Max. drag indicator	42.000	bar	drkuMx
D	33 Current gradient	0.000	bar/s	drkuGdt
D	34 Second mean	42.000	bar	drkuSmiw
D	35 Minute mean	42.000	bar	drkuMmiw
D	36 Hourly mean	42.000	bar	drkuHmiw
D	37 Ongoing mean	42.000	bar	drkuCEmiw
D	38 Standard deviation	0.000	bar	drkuStAb
D	47 Revision mean	42.000	bar	drkuRmiw
D	48 retain value	42.000	bar	drkuLW
D	49 Daily mean	42.000	bar	drkuTmiw
E *	50 Manufacturer	Rosemount		drkuManuf
E *	51 Device type	3051CA		drkuGerTp
E *	52 Serial number	0		drkuSerNr
F	61 Measured value	42.000	bar	fdrku
F	62 Input value	42	bar	fdrkuQll

Enter Cancel Load defaults Refresh

**Figure 125: Menu OB Overpressure**

The environmental pressure is adjusted in coordinate **OB15 Environmental pressure**.



### 4.3 Temperature transducer

The gas temperature is displayed as menu "AC Gas temperature" as a second measurement value.

#### AC Gas temperature

Access Line	Designation	Value	Unit	Variable
A *	1 Measured value	293.15	K	temp
A *	2 Input value -> AC05	293.15	K	tempOll
E *	3 Operating mode	Default		tempMod
G *	4 Unit	K		tempDim
B	5 Default	293.15	K	tempVq
B	6 Lower warning limit	273.15	K	tempWGwu
B	7 Upper warning limit	313.15	K	tempWGwo
E *	8 Lower alarm limit	253.15	K	tempAGwu
E *	9 Upper alarm limit	323.15	K	tempAGwo
E *	10 Coefficient 0	0		tempK0
E *	11 Coefficient 1	0		tempK1
E *	12 Coefficient 2	0		tempK2
E *	13 Coefficient 3	0		tempK3
E *	19 Source	OFF		tempInp
E *	21 Correction value	0.00	K	tempKorr
E *	22 Max. gradient	10	K/s	tempMGdt
D	24 Base value	293.15	K	tempOrg
D	25 Mean for DSFG	293.15	K	tempEmiw
A *	26 Joule-Thomson-dT	0.000000	K	dtit
D	27 Current status	Fixed value		tempCEstt
D	28 DSFG status	Fixed value		tempEstt
D	29 Used range	333.15	K	tempMb
G *	30 Format	% .2f		tempFrm
D	31 Min. drag indicator	0.00	K	tempMn
D	32 Max. drag indicator	333.15	K	tempMx
D	33 Current gradient	0.00	K/s	tempGdt
D	34 Second mean	293.15	K	tempSmiw
D	35 Minute mean	293.15	K	tempMmiw
D	36 Hourly mean	293.15	K	tempHmiw
D	37 Ongoing mean	293.15	K	tempCEmiw
D	38 Standard deviation	0.00	K	tempStAb
D	47 Revision mean	293.15	K	tempRmiw
D	48 retain value	293.15	K	tempLW
D	49 Daily mean	293.18	K	tempTmiw
E *	50 Manufacturer	ROSEMOUNT		tempManuf
E *	51 Device type	Pt100		tempGerTp
E *	52 Serial number	0		tempSerNr
D	53 unit of scale		K	tempDDim
F	61 Measured value	293.15	K	ftemp
F	62 Input value	293.15	K	ftempOll

Enter	Cancel	Pt100	Refresh
		3144P	
		APT-2000 ALW	
		248	
		644	
		TMT82	

Figure 126: Menu AC Gas temperature

The menu essentially has the same layout as that of absolute pressure and thus does not have to be explained in detail.

The lower part provides a pre-selection of approved temperature transmitters, which can be selected. If you select one of these temperature transmitters, there are pre-settings with which - like above - the entered data has a bright yellow-green background.

If the operating mode is set to "Default" an automatic identification of the three different resistance designations (PT100, PT500 and PT1000) for temperature measurement takes place. The characteristic curve of these resistance measurements as a function of the temperature is not exactly linear and can be described by a polynomial with 4 coefficients (0, 1, 2, 3) – according to Callendar - Van Dusen. Then the corresponding coefficients can be entered.

The **AC26 Joule-Thomson dT** is also different. It describes the temperature change of the gas with a change in pressure without supply or removal of energy.

### 4.3.1 AL internal temperature of the device

#### AL Inside temperature of device

Access Line	Designation	Value	Unit	Variable
D	1 Measured value	41.1	°C	<a href="#">gerTemp</a>
D	2 Input value	1206	Ohm	<a href="#">gerTempKty</a>
B	6 Max. oper.temp.	<input type="text" value="60.0"/>	°C	<a href="#">gerTempGwo</a>
B	7 Min. oper.temp.	<input type="text" value="-20.0"/>	°C	<a href="#">gerTempGwu</a>
B	21 Correction	<input type="text" value="-8.5"/>	°C	<a href="#">gerOffs</a>
I	26 Converter value	005F4000	hex	<a href="#">gerTempHex</a>

Enter Cancel Load defaults Refresh

**Figure 127: Menu AL internal temperature of the device**

The internal temperature of the ERZ2000-NG **AL01 Measured value** is measured near the analog/digital converter. The value can be output as a current output for monitoring purposes. The measurement variable can be adjusted to the level of the prevalent temperature with **AL21 Correction**.

## 4.4 Special measurements

### OF Extra analog value 1

Access Line	Designation	Value	Unit	Variable
D 1	Measured value	50.000	%	<a href="#">ana1</a>
D 2	Input value -> <a href="#">OF05</a>	50.000	%	<a href="#">ana1Qll</a>
B 3	Operating mode	<input type="text" value="OFF"/>		<a href="#">ana1Mod</a>
B 4	Unit	<input type="text" value="%"/>		<a href="#">ana1Dim</a>
B 5	Default	<input type="text" value="50.000"/>	%	<a href="#">ana1Vg</a>
B 6	Lower warning limit	<input type="text" value="0.000"/>	%	<a href="#">ana1WGwu</a>
B 7	Upper warning limit	<input type="text" value="100.000"/>	%	<a href="#">ana1WGwo</a>
B 11	Coefficient 0	<input type="text" value="0"/>		<a href="#">ana1K0</a>
B 12	Coefficient 1	<input type="text" value="100"/>		<a href="#">ana1K1</a>
B 13	Coefficient 2	<input type="text" value="0"/>		<a href="#">ana1K2</a>
B 14	Coefficient 3	<input type="text" value="0"/>		<a href="#">ana1K3</a>
B 16	1st source	<input type="text" value="OFF"/>		<a href="#">ana1Inp</a>
B 18	2nd source	<input type="text" value="OFF"/>		<a href="#">ana1Inp2</a>
B 19	Internal choice = <a href="#">AC01</a> <a href="#">Edit</a>		K	<a href="#">ana1Ausw</a>
D 21	Base value	50.000	%	<a href="#">ana1Orq</a>
D 22	Mean for DSFG	50.000	%	<a href="#">ana1Emiw</a>
D 25	2nd input value	(....)		<a href="#">ana1Qll2</a>
D 27	Current status	Stop		<a href="#">ana1CEstt</a>
D 28	DSFG status	Stop		<a href="#">ana1Estt</a>
G *	Format	<b>%.<b>3f</b></b>		<a href="#">ana1Frm</a>
D 37	Ongoing mean	50.000	%	<a href="#">ana1CEmiw</a>
B 53	Symbol	<input type="text" value="value1"/>		<a href="#">ana1Symbol</a>

**Figure 128: Menu OF Special measurement 1**

Free inputs (up to 8) can be assigned with signals in a similar manner to the custody-transfer-relevant measuring inputs. These must be treated analogously to all other measurement values (see above) in regard to their settings.

## 5 Flow meters

Basically, the ERZ2000-NG can work with all flow rate measuring devices that are used in the flow rate measurement of gas. However, the ERZ2000-NG offers the possibility of using pre-settings which can be adjusted with the measurement processes that are normally used. These are turbine wheel gas meters, differential pressure flow meters and ultrasonic gas meters.

The most important parameters for flow meters of gases are summarized below; in the process, directly measured values, such as ultrasonic running times, and derived values, such as the average speed are differentiated between (both with the ultrasonic gas meter in this case). Some basic functions of the various flow rate measurement principles are explained to the necessary extent for better understanding.

Some functions are independent of the present measurement principle. They are presented first.

### 5.1 General settings

#### 5.1.1 AQ 4-20 mA flow

##### AQ Flow proportional signal

Access Line	Designation	Value	Unit	Variable
A *	1	Flow 4-20mA	0.00	m3/h Qp
A *	2	Input value	(...)	QpQll
E *	3	Source	OFF	QpInp
E *	4	zero point noise	0.00	m3/h QpNull
D	20	volume slice	.000000	m3 QpZykMng
D	21	time slice	0.000000	s QpTZyk

Enter Cancel Load defaults Refresh

Figure 129: Menu AQ 4-20 mA flow

The transmission of the flow rate value takes place via an analog current input. The source must be specified in **AQ03**. AQ04 enables suppression of noise and leak flow values.

### 5.1.2 GB Flow rate parameters

#### GB Flow rate parameters

Access Line	Designation	Value	Unit	Variable
A *	1 Qm max	1000.000	m3/h	<a href="#">quMax</a>
A *	2 Qm min	0.000	m3/h	<a href="#">QuMin</a>
E *	3 High pressure ext.	No		<a href="#">HdErw</a>
E *	4 Qm,min	0.000	m3/h	<a href="#">QbMinLD</a>
E *	5 Qm,min (HP)	50.000	m3/h	<a href="#">QbMinHD</a>
E *	6 Qm max	1000.000	m3/h	<a href="#">QuMax</a>
E *	7 Pe,min	1.0	MPa	<a href="#">PeMin</a>
E *	8 Pe,max	100.0	MPa	<a href="#">PeMax</a>
E *	9 Rho,min	1.0	kg/m3	<a href="#">RbeMin</a>
E *	10 Rho,max	100.0	kg/m3	<a href="#">RbeMax</a>
E *	11 certified	For air		<a href="#">geprueft</a>
E *	12 used	For natural gas		<a href="#">eingesetzt</a>
E *	13 Creeping qty limit	1.500	m3/h	<a href="#">leakFlow</a>
E *	14 Creeping qty mode	Discard		<a href="#">leakMode</a>
E *	15 LF measurable	Yes		<a href="#">Lf2Qb</a>
E *	16 Vol.transd. mode	LF1-ch.		<a href="#">volGebMod</a>
E *	17 Start-up pulses	500	pulses	<a href="#">anlaufPulse</a>
E *	18 Missing pulses	10	pulses	<a href="#">hf_10</a>
E *	19 Reference pulses	10000	pulses	<a href="#">hf_10000</a>
E *	20 mx.allow. Dev.X/Y	4.000	%	<a href="#">limXY</a>
A *	21 act. Dev. X/Y	0.000	%	<a href="#">mixXY</a>
A *	23 Channel Qm det.	LF		<a href="#">flsKanal</a>
A *	25 Channel Vm determ.	LF		<a href="#">zwkKanal</a>
A *	27 Hardw.pulse comp.	OFF		<a href="#">HWPlausib</a>
A *	29 Vo effect of fault	OFF		<a href="#">voErr</a>
A *	31 Main blades (X)	200	pulses	<a href="#">x_vh</a>
A *	32 Ref. blades (Y)	200	pulses	<a href="#">y_vh</a>
A *	33 Better HF channel	Uncertain		<a href="#">hfKanal</a>
B	34 Predict.reliability	5		<a href="#">hfChks</a>
D	35 Decision change	0		<a href="#">hfwchsl</a>
A *	36 USZ effect of fault	OFF		<a href="#">dzuErr</a>
A *	37 Vol.alarm contact	OFF		<a href="#">ktkVolAlarm</a>
E *	38 Source vol.alarm	OFF		<a href="#">kzoVolAlarm</a>
D	39 Vol.warn contact	OFF		<a href="#">ktkVolWarn</a>
B	40 Source vol.warn	OFF		<a href="#">kzoVolWarn</a>
E *	50 Manufacturer	RMG		<a href="#">zwkManuf</a>
E *	51 Device type	TRZ03		<a href="#">zwkGerTp</a>
E *	52 Serial number	0		<a href="#">zwkSerNr</a>
E *	53 Meter type	TM		<a href="#">zwkPrinzip</a>
E *	54 Meter size	G650		<a href="#">zGroesse</a>
Q	55 Freq.turbinesim.	0	Hz	<a href="#">hfSim</a>

Enter Cancel DSfG: F-Instanz COM6/7 Refresh

Figure 130: Menu GB Flow rate parameters

Like pressure and temperature, the data of the gas meter which is used must be communicated to the computer and parameters such as type / manufacturer / serial number, etc. must be entered in the chapter Meters / flow rate parameters. This data will then appear automatically in the type plate display. Then, the essential physical values for operation of a flow rate measurement device in menu **GB Flow rate parameters**. First, the measuring range  $Q_{b,min}$  to  $Q_{b,max}$  must be adjusted under Operating conditions in coordinates **GB04 / GB05** and **GB06**.

**Note**

**Some measurement techniques for volume flow rate detection permit use of a larger measuring range if the flow rate measurement takes place under higher pressure.**

This option can be selected in coordinate **GB03 High-pressure ext.**. Then, – with high pressure – the minimum permissible volume flow can be decreased. Since the density is correlated with the pressure, there are three setting options: "no", "via pressure" and "via density".

**Comment**

The density of a gas is increasingly less frequently determined via a direct density transmitter, so the third variant only applies in isolated cases.

The minimum permissible measurable volume flow must be entered in coordinates **GB04  $Q_{b,min}$**  and **GB05  $Q_{b,min}$  (HD)**. " $Q_{b,min}$  (HD)" includes the minimum flow rate under high-pressure conditions.

**Note**

**If you operate your flow rate meter under high-pressure conditions, inquire with the manufacturer of the flow meter device whether your volume transmitter offers an expanded flow rate measuring range.**

The values in coordinates **GB07  $P_{e,min}$**  and **GB08  $P_{e,max}$**  describe the permissible limits of the pressure range in which the measuring device should be operated. The values in coordinates **GB09  $Rho,min$**  and **GB10  $Rho,max$**  describe the permissible limits of the density range in which the measuring device should be operated.

**Note**

**The density of gas, which should be detected by your flow rate meter, is pressure-dependent. The limit values must be entered depending on the pressure.**

In the coordinates **GB11 certified** and **GB12 used** the gas tested by your flow rate transmitter or available for selection must be entered. Available for selection: natural gas, air, ethylene, nitrogen, hydrogen, oxygen and "see gas meter". The last item "see gas meter" stands for other possibilities.

In coordinate **GB13 Creeping qty limit**, a limit value significantly below the lower measuring range limit is usually defined, below which flow rates are "rejected" (or "included") (coordinate **GB14**), i.e. the counter statuses Vm and Vb are not increased as long as the flow rate at meas. cond. is below the *Leak flow volume limit* threshold.

The leak flow volume shut-off function prevents uncontrolled metering of pulses, e.g. in case of pendulum movements while a turbine meter is at a standstill or with pulses in zero-point operation of other meters.

Coordinate **GB15 LF measurable** defines whether the current flow rate is calculated from the transmitted low frequency or the volume flow is merely totaled, i.e. added up.

Multiple values can be adjusted in coordinate **GB16 Vol.transd mode**. This describes how and how many independent flow rate measurement values are transmitted to the ERZ2000-NG. In the process, 1-C means a 1-channel and 2-C means a 2-channel transmission of flow rate values. The different transmission types are:

LF	Low Frequency Since a very low frequency can be present, <b>no</b> current flow rate is calculated from this.
HF	High Frequency The current flow rate is calculated here.
Vc	Original counter, the direct value of the encoder. The current flow rate is <b>not</b> calculated here.
1/1	The same frequency is transmitted, which reversed 180° by RMG.
X/Y	either: The same frequency is transmitted, (with unknown phase relationship) or: The transmitted frequencies are not equal. <b>Important:</b> In this case, 2 kv factors must be entered.
ENCO	ENCODER / electronic counter with digital interface

**Table 3: Explanation of terms Transfer of the volume transmitter**

Typically, the following operating modes are available:

HF LF	Two-channel operation with: HF input as a measuring channel and LF input as a comparison channel  Typical for the following flow rate meters: turbines, rotary piston meters, vortex meters, etc.
DZU	Vm is delivered via DZU protocol  Typical for ultrasonic flow rate meters

### Note

As a new standard from 2017, connection as DZU via the DSfG: F instance will be more prevalent. (see trigger under *Figure 130: Menu GB Flow rate parameters*)

4-20 mA	Processing of an analog signal proportional to the flow rate. A current input must be selected as source with <b>AQ Flow proportional signal</b> in coordinate <b>AQ03 Source</b> .
---------	--

### Note

If multiple flow rate data variables are transmitted, e.g.

"Vc, HF2-K 1/1"

Then, the first listed flow rate specification ("Vc" in this case) is the totalizer and is used for billing. The other flow rate data ("HF2-K 1/1" in this case) is stored in the archives and can be used for comparison or redundancy.

Flow rate measuring devices from RMG typically transmit 3 values:

**RMG-typical <sup>1)</sup>: "HF 2-K 1/1, Vc"**

- 1) The first high-frequency input HF operates the totalizer and is used for billing. The second high-frequency HF with phase reversed 180° and the direct encoder value Vo can be stored and used for comparison or redundancy.



**Note**

**It is not possible to operate two independent volume measurements with two volume transmitters.**

**Available for selection in GB16:**

LF1-ch.	Single-channel operation with LF input only counting, no flow rate, there is no lower shut-off limit (leak flow volume)
HF1-ch.	Single -channel operation with HF input
HF2-ch. 1/1	Two-channel operation with HF inputs Same significance. The input pulses are applied with shifted phase. The difference formation compares the alternating measurement and comparison pulse. Any deviation is counted in the pulse disturbance counter. An alarm is generated if the adjusted limit value is exceeded ( <b>GB18 Missing pulses</b> = e.g. 10 pulses). If the limit value is not exceeded within an adjustable period ( <b>GB19 Reference pulses</b> = e.g. 10000 pulses), the pulse disturbance totalizer is set to zero. The Vm progress and flow rate are calculated from the "better" HF input.
HF2-ch. X/Y	Two-channel operation with HF inputs Different significance. The difference formation and comparison take place in the software only. An alarm is generated in case of a deviation. The Vm progress and flow rate are calculated from the "better" HF input.
HF LF	Two-channel operation with HF input (measuring channel) and LF input (comparison channel) The difference formation and comparison take place in the software only. An alarm is generated in case of a deviation. With a changeover to the comparison channel (e.g. in case of an error, only a flow rate with reduced accuracy can be calculated.
Vo	Vm is calculated from Vo, ENCO counter delivers data via protocol
Vo, LF1-ch.	Vm is calculated from Vo, LF input is used for comparison
Vo, HF1-ch.	Vm is calculated from Vo, HF input is used for comparison. An alarm is triggered in case of synchronization errors.
Vo, HF2-ch. 1/1	Vm is calculated from Vo, The HF inputs are used for comparison and for checking for synchronization and calculation of the flow rate (selection 1

	and 3). With synchronization errors, a warning message is triggered and a switchover to the plausible input takes place.
Vo, HF2-ch. X/Y	V <sub>m</sub> is calculated from V <sub>o</sub> , HF inputs are used for comparison, checking for synchronization and calculation of the flow rate (selection 1 of 3). With synchronization errors, an alarm is triggered and a switchover to the plausible input takes place.
LF1-ch., V <sub>o</sub>	V <sub>m</sub> is calculated from the input signal, V <sub>o</sub> is only used for comparison and the check for synchronization and, otherwise, is only displayed and registered. An alarm is triggered in case of synchronization errors, then no changeover to V <sub>o</sub> takes place. A flow rate with reduced accuracy is determined from the LF signal.
HF1-ch., V <sub>o</sub>	V <sub>m</sub> is calculated from the input signal, V <sub>o</sub> is used for comparison only. An alarm is triggered in case of synchronization errors.
HF2-ch. 1/1, V <sub>o</sub>	V <sub>m</sub> is calculated from the input signal, V <sub>o</sub> is used for comparison and the check for synchronization (selection 1 of 3) and, otherwise, is only displayed and registered. An alarm is triggered in case of synchronization errors, then no changeover to V <sub>o</sub> takes place.
HF2-ch. X/Y, V <sub>o</sub>	V <sub>m</sub> is calculated from the input signal, V <sub>o</sub> is used for comparison and the check for synchronization (selection 1 of 3) and, otherwise, is only displayed and registered. An alarm is triggered in case of synchronization errors, then no changeover to V <sub>o</sub> takes place.
USZ	V <sub>m</sub> is delivered via DZU protocol. Connection of an ultrasonic gas meter (USZ08 or USM-GT400) with main totalizer function, transmission of totalizer statuses and flow rates with the DZU protocol. Information about the protocol is available in menu <b>LO DZU Protocol</b>
IGM	Activate integrated ultrasonic controller Sensor data is delivered from the ultrasonic measuring head
Orifice plate	An orifice plate is used for volume calculation (for ERZ2014, ERZ2114, ERZ2012, ERZ2112) Delta-p transducers are connected, wherein up to 3 stepped transducers can be accommodated. In the process, monitoring of the overlapping ranges takes place during run-up and after-run.
4-20mA	Processing of an analog signal proportional to the flow rate. A current input must be selected as source with <b>AQ 4-20mA flow</b> . The assignment takes place: 4 mA = 0 m <sup>3</sup> /h, 20 mA = Q <sub>b,max</sub> ( <b>GB06</b> ).
sim. turbine freq.	If no real volume transmitter is available, a turbine can be

	simulated for test purposes. The frequency is adjusted with coordinate <b>GB55 Freq.turbinesim.</b>
USC, HF1-ch.	Vm is delivered via DZU protocol, HF input is used for comparison
USC, HF2-ch. 1/1	Vm is delivered via DZU protocol, HF inputs are used for comparison
USC, LF1-ch.	Vm is delivered via DZU protocol, LF input is used for comparison

The following must be considered for the reporting of alarms or warnings: If ENCO is at the beginning with a 2-channel operating mode, with HF measuring inputs at the end, a warning with separate message number is issued instead of an alarm in case of a pulse failure or pulse comparison error.

### Logic of the synchronization monitoring

The synchronization monitoring is focused on the software comparison between two possible inputs for volume formation. The comparison takes place automatically with more than 1 input. The synchronization monitoring checks all combinations with more than one input and is not limited to the comparison between Vo and LF input. The following table provides an overview of the functions in error-free operation. In case of an error, the ERZ2000-NG uses the undisturbed signal or, with 3 input signals, it automatically switches over to the appropriate signal.

Operating mode	Errors Vc	DZU error	HW Comp.	SW Comparison	QB Bill.	Vm Bill.	Kv Use
Vo	alarm	Off	Off	Off	Metering mode	Vo	Vo
Vo, LF1-ch.	alarm	Off	Off	Vo -- LF1-ch.	Metering mode	Vo	Vo
LF1-ch., Vo	warning	Off	Off	LF1-ch. -- Vo	Metering mode	LF	meas. ch.
Vo, HF-1ch.	alarm	Off	Off	Vo -- HF-1ch.	HF Signal	Vo	Vo
HF1-ch., Vo	warning	Off	Off	HF1-ch. -- Vo	HF Signal	HF Signal	meas. ch.
Vo, HF2-ch. 1/1	alarm	Off	1:1	Vo--HF meas.	HF meas. signal	Vo	Vo
HF2-ch. 1/1, Vo	warning	Off	1:1	HF meas.--Vo	HF meas. signal	HF meas. signal	meas. ch.
Vo, HF2-ch. X/Y	alarm	Off	X:Y	Vo--HF meas.	HF meas. signal	Vo	Vo
HF2-ch. X/Y, Vo	warning	Off	X:Y	HFmeas. -- Vo	HF meas. signal	HF meas. signal	meas. ch.
HF2-ch. 1/1	Off	Off	1:1	Meas.-- comp.	HF meas. signal	HF meas. signal	meas. ch.
HF2-ch. X/Y	Off	Off	X:Y	Meas.-- comp.	HF meas. signal	HF meas. signal	meas. ch.
HF LF	Off	Off	Off	HF -- LF	HF Signal	HF meas. signal	meas. ch.
HF1-ch.	Off	Off	Off	Off	HF Signal	HF Signal	meas. ch.
LF1-ch.	Off	Off	Off	Off	Metering mode	LF Signal	meas. ch.
DZU	Off	alarm	Off	Off	DZU	DZU	DZU
IGM	Off	Off	Off	Off	IGM	IGM	IGM

Coordinates **GB17** to **GB20** are used for comparison of two frequencies. The first **GB17 Start-up pulses** are not considered for the comparison. This is especially critical with a 2-channel volume measurement, which is based on different frequencies. The monitoring is only activated after the expiration of the **GB17 Start-up pulse**. In addition, fault messages of the volume input are reset after resumption of undisturbed interruption and after the expiration of the **GB17 Start-up pulse**.

A differential circuit compares the metered pulse of measuring and comparison channels alternatingly. Any deviation is counted in the internal pulse failure counter. An alarm is generated if the adjusted limit value is exceeded (**GB18 Missing pulses**). If the limit value is not exceeded within an adjustable period (**GB19 Reference pulses**), the pulse failure totalizer is set to zero. **GB20 mx.allow.Dev.X/Y** specifies how large the relative deviation of the totaled volume flows (**GB19 Reference pulse** of the billing totalizer) may be for transmission with two different frequencies.

#### **Start-up and shut-down a system:**

A fault-free start-up takes place if  $Q_m$  runs in the range between the leak volume limit and the lower alarm limit within the start-up and shut-down time. An alarm is generated if  $Q_m$  is still below the alarm limit and above the lower leak volume limit after the start-up/shut-down time is exceeded. The outgoing alarm is defined by violation of the upper alarm limit (on start-up of the system) or a violation of the leak volume limit (on shut-down of the system).

Coordinates **GB23** to **GB35** are auxiliary indicators for making a comparison between the different input frequencies for the purpose of optimization. The device calculates the optimal number of pulses for the impeller monitoring from the c-factors. A number of tests is defined for the decision of which is the better HF channel. **GB35** displays how many changes have already taken place.

Coordinate **GB31 Main blades (X)** shows the integral ratio of Kv measuring channel to Kv comparison channel, counted up to about 200 pulses. The achieved values are transmitted to the hardware pulse comparison logic automatically. **Coordinate GB32 Ref. blades (Y)** shows the integral ratio of Kv comparison channel to Kv measuring channel, counted up to about 200 pulses. The achieved values are transmitted to the hardware pulse comparison logic automatically.

Coordinate **GB33 Better HF channel** shows the comparison of frequencies of measuring channel and comparison channel, relative to the larger value.

The comparison of two totalizers is activated in menu **LL Monitoring of synchronous run** with coordinate **LL09 Sync.run active**. In the process, the volume for the comparison is defined in **LL06 Termination qty**.

**LL Monitoring of synchronous run**

Access Line	Designation	Value	Unit	Variable
D 1	Comparative error	0.0000	%	<a href="#">vglErr</a>
D 2	State of comparison	At rest		<a href="#">vglState</a>
D 3	Synchronous run	OFF		<a href="#">SWPlausib</a>
D 4	Channel 1	0.000	m3	<a href="#">vglh</a>
D 5	Channel 2	0.000	m3	<a href="#">vglr</a>
T 6	Termination qty	<input type="text" value="1000.000"/>	m3	<a href="#">vglinmax</a>
T 7	Termination short	<input type="text" value="100.000"/>	m3	<a href="#">vglemax</a>
T 8	Max. deviation	<input type="text" value="4.00"/>	%	<a href="#">SWmaxAbw</a>
T 9	Sync.run active	<input type="text" value="Yes"/>		<a href="#">SWPaktiv</a>
D 10	Reference quality	Inactive		<a href="#">refKanal</a>

**Figure 131: Menu: LL Synchronization monitoring**

The volume in **LL07 Termination short** is the reference variable which is used after a fault message with the termination quantity from **LL06**. Then, the time until release after elimination of a fault can be decreased.

The value in coordinate **GB34 Predict. reliability** indicates how often the comparison from **GB33 Better HF channel** must deliver the better value before a change-over takes place. Coordinate **GB35 Decision change** indicates how often the ERZ2000-NG has selected the other channel.

Whether the alarm output of third-party volume transmitters is activated can be defined in **GB37**. The corresponding contact input for an alarm must be selected in **GB38**. The same applies for a warning in coordinate **GB40**.

The manufacturer must be entered in coordinate **GB50**, the device type in **GB51** and the serial number of the flow rate meter in **GB52**. The flow rate measuring process must be specified in **GB53**:

<b>TRZ</b>	Turbine meter
<b>DKZ</b>	Rotary piston meter
<b>WBZ</b>	Vortex meter
<b>USZ</b>	Ultrasonic meter
<b>BGZ</b>	Diaphragm meter
<b>Special design</b>	Special designs and other measuring processes
<b>Orifice plate</b>	Differential pressure meter

**Table 4: Explanation of terms Flow rate measuring processes**

The meter variable of the flow rate transmitter must be entered in coordinate **GB54**.

If no real volume transmitter is available, a turbine with the frequency adjusted in GB55 can be simulated for test purposes. For this purpose, the setting must be adjusted to "sim. turbine freq." in operating mode **GB16 Volume transmitter mode**.

### 5.1.3 GC kv factor

#### GC kv factor

Access Line	Designation	Value	Unit	Variable
A *	1	Cur.kv factor	6600.00000	P/m3 <a href="#">kvAkt</a>
A *	2	Mean kv factor	6600.00000	P/m3 <a href="#">kvMAkt</a>
A *	3	Mom.dev. at op.pt.	0.000	% <a href="#">dkvk</a>
D	4	Qm percentage	0.000	% <a href="#">QuProz</a>
A *	5	Current direction	Forwards	<a href="#">kvDirec</a>
A *	6	Cur.kv set	kv= Main	<a href="#">kvSatz</a>
E *	7	kv main/forwards	6600.00000	P/m3 <a href="#">kvMx</a>
E *	8	kv ref./forwards	6600.00000	P/m3 <a href="#">kvMy</a>
E *	9	kv main/rev.	6600.00000	P/m3 <a href="#">rkvMx</a>
E *	10	kv ref./rev.	6600.00000	P/m3 <a href="#">rkvMy</a>
F	61	Current kv factor	6600.00000	P/m3 <a href="#">fkvAkt</a>
F	62	Mom.dev. at opr.pt.	0.000	% <a href="#">fdkvk</a>
F	63	Qm percentage	0.000	% <a href="#">fQuProz</a>

Enter Cancel Load defaults Refresh

**Figure 132: Menu GC kv factor**

The conversion factors of the frequency of the flow rate measuring devices in the volume flow are specified in menu **GC kv factor**.

#### Note

The actual pulse significance used in GC01 can deviate from the value in GC02, e.g. if a characteristic curve correction is applied.

The pulse significances for the measuring and comparison channel are adjusted separated for meters with forward and backward flows in coordinates **GC07** to **GC10**.

### 5.1.4 GD Characteristic curve determination

#### GD Determination of characteristic

Access Line	Designation	Value	Unit	Variable
A *	1 Cur.kv factor main	6600.00000	P/m3	kvAktx
A *	2 Cur.kv factor ref.	6600.00000	P/m3	kvAkty
A *	3 Mean kv factor main	6600.00000	P/m3	kvMAktx
A *	4 Mean kv factor ref.	6600.00000	P/m3	kvMAkty
D	5 Lower neighbour	-1		drunter
D	6 Upper neighbour	-1		drueber
E *	7 kv mode	Interp.point RMG		kvMode
E *	8 Max.dev. at op.pt.	2.00000	%	dkvkmax
E *	9 Op.pt.dev.mode	W/o correction		dkvkMod
G *	10 Unit	P/m3		kvDim
E *	11 Direction mode	Always forwards		kvDirecMode
E *	12 Direction BM1	Forwards		am1Direc
E *	13 Direction BM2	Reverse		am2Direc
E *	14 Direction BM3	Forwards		am3Direc
E *	15 Direction BM4	Reverse		am4Direc

Enter Cancel DSfG: F-Instanz.COM6/7 Refresh

Figure 133: Menu GD Characteristic curve determination

The Kv factors for the main and reference meters in forward and backward operation are displayed in coordinates **GD01** to **GD04**.

The numbers of the next support points below or above the current percentage flow are displayed in coordinates **GD05** and **GD06**. If the value -1 is displayed, the percentage flow for the current time is above or below the lowest support point.

Flow meters with integrated electronics in which a first correction has already been made must and should not be corrected further.

Whether calculation should take place with or without correction processes is defined in coordinate GD07. Available for selection:

#### Interpol. point RMG

The characteristic curve is reconstructed in up to 16 interpolation points. Normally, a higher number of interpolation points in the lower flow rate range is beneficial, because the deviations from

$$kv = \text{const.}$$

are the greatest.

With flow rate meters which have minor variance of the characteristic, 4 interpolation points, which are offered with "RMG support point" are used.

**Polynomial method**

There are various ways to describe the characteristic curve. These methods are usually more accurate in the lowest flow rate range, particularly when no support point correction takes place here.

"Polynomial Q RMG" describes the typical characteristic curve for RMG meters. With "Polynomial Re RMG", a Reynolds-number dependency is also taken into consideration. "Straatsma" is a seldom-used special form.

**Note**

If "DsfG: F instance COM6/7" is selected under the table, "cv = constant" is adopted for the kv mode.

Coordinate **GD09** defines whether calculation continues with or without a correction after a maximum deviation **GD08** has been exceeded.

Coordinate **GD11** determines the assignment in (or against) the direction of the route as a fixed assignment or it depends on the billing mode.

The direction of the different billing modes is defined according to a direction table in coordinates **GD12** to **GD15**.



### 5.1.5 GE Error curve linearisation, forward flow

#### GE Error curve linearization, forward flow

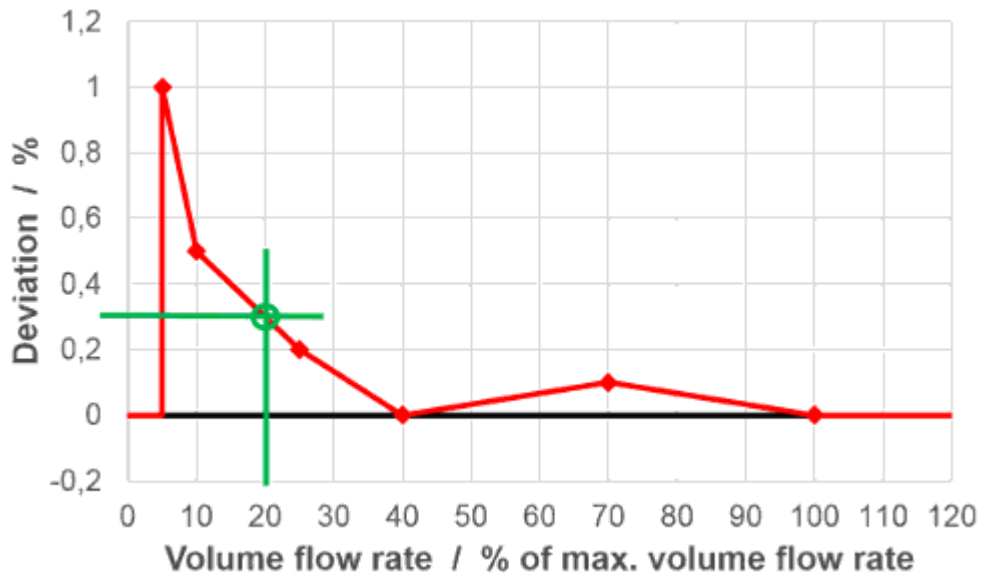
Access Line	Designation	Value	Unit	Variable	
E *	1	Interp.point 1	5	%	StzPkt1
E *	2	Corr.point 1	1	%	KrrPkt1
E *	3	Interp.point 2	10	%	StzPkt2
E *	4	Corr.point 2	0.5	%	KrrPkt2
E *	5	Interp.point 3	25	%	StzPkt3
E *	6	Corr.point 3	0.2	%	KrrPkt3
E *	7	Interp.point 4	40	%	StzPkt4
E *	8	Corr.point 4	0	%	KrrPkt4
E *	9	Interp.point 5	70	%	StzPkt5
E *	10	Corr.point 5	0.1	%	KrrPkt5
E *	11	Interp.point 6	100	%	StzPkt6
E *	12	Corr.point 6	0	%	KrrPkt6
E *	13	Interp.point 7	-1	%	StzPkt7
E *	14	Corr.point 7	0	%	KrrPkt7
E *	15	Interp.point 8	-1	%	StzPkt8
E *	16	Corr.point 8	0	%	KrrPkt8
E *	17	Interp.point 9	-1	%	StzPkt9
E *	18	Corr.point 9	0	%	KrrPkt9
E *	19	Interp.point 10	-1	%	StzPkt10
E *	20	Corr.point 10	0	%	KrrPkt10
E *	21	Interp.point 11	-1	%	StzPkt11
E *	22	Corr.point 11	0	%	KrrPkt11
E *	23	Interp.point 12	-1	%	StzPkt12
E *	24	Corr.point 12	0	%	KrrPkt12
E *	25	Interp.point 13	-1	%	StzPkt13
E *	26	Corr.point 13	0	%	KrrPkt13
E *	27	Interp.point 14	-1	%	StzPkt14
E *	28	Corr.point 14	0	%	KrrPkt14
E *	29	Interp.point 15	-1	%	StzPkt15
E *	30	Corr.point 15	0	%	KrrPkt15
E *	31	Interp.point 16	-1	%	StzPkt16
E *	32	Corr.point 16	0	%	KrrPkt16
E *	33	Coefficient A-2	-1503.953000		pkam2
E *	34	Coefficient A-1	97.168000		pkam1
E *	35	Coefficient A 0	-0.379000		pkap0
E *	36	Coefficient A 1	7.391000	*10^-4	pkap1
E *	37	Coefficient A 2	-44.335000	*10^-8	pkap2
E *	38	Straatsma A0	0.000000		straat0
E *	39	Straatsma A1	0.000000		straat1
E *	40	Straatsma A2	0.000000		straat2
E *	41	Straatsma A3	0.000000		straat3

Figure 134: Menu GE Forward operation characteristic curve correction

There are 16 support point pairs for forward operation and the polynomial coefficients (at the end of the table). If "without correction" is entered in **GD07** for **GD Determination of characteristic**, the values still used again without correction. This corresponds to the value "0" in all defaults of the correction points. The entered values are adopted accordingly if the parameter is set to "with correction". *Figure 135: Characteristic correction* shows how a correction takes place for the values provided in *Table 5: Support point correction* (**Note:** the values match the values in *Figure 134: Menu GE Forward operation characteristic curve correction*).

Support point [%]	5	10	25	40	70	100
Deviation [%]	1.0	0.5	0.2	0.0	0.1	0.0

**Table 5: Support point correction**



**Figure 135: Characteristic correction**

The deviation is approximated linearly between the interpolation points. *Figure 135: Characteristic correction* indicates the deviation 0.3% for the operating point 20%. Therefore, the correction is calculated as follows:

$$\begin{aligned}
 \text{displayed value} &= \frac{\text{measured value}}{(1 + \text{deviation})} \\
 &= \frac{\text{measured value}}{(1 + 0.3)} \\
 &\approx \text{measured value} \cdot 0,997
 \end{aligned}$$

In the process, the display value is also the value that is used for volume flow correction.

If you would like to use less than 15 interpolation points (like in the example above), enter (-1) for the respective interpolation point, so all drawn points are ignored. Outside of the range in which there are no correction values, i.e. below the lowest and above the highest support point, no correction is made, i.e. the correction value is set to "0".

**Note**

**The entry of the interpolation points can be carried out in any arbitrary sequence; the ERZ2000-NG sorts them automatically.**

**Characteristic curve correction with polynomial, relative to the flow rate**

The correction takes place with a 4th degree polynomial which represents the error curve of the gas meter depending on the flow rate. The error equation is:

$$F = A_{-2} \cdot \frac{1}{Q_{vb}^2} + A_{-1} \cdot \frac{1}{Q_{vb}} + A_0 + A_1 \cdot Q_{vb} + A_2 \cdot Q_{vb}^2$$

Where:

- $F$  = error curve deviation [%]
- $Q_{vb}$  = volume flow rate at meas. cond. [m3/h]
- $A_n$  = constants

The polynomial coefficients  $A_n$  ( $n = -2, -1, 0, 1, 2$ ) are calculated from the measured value pair error  $F_i$  and flow rate  $Q_{vb,i}$ . Instead of the constant meter factor  $K_V$ , the corrected meter factor  $K_{VK}$  is used for further calculation and/or conversion.

$$K_{VK} = K_V \cdot \left(1 + \frac{F}{100}\right)$$

The polynomial coefficients  $A_n$  are delivered by the manufacturer of the flow rate measuring device (turbine meter, ultrasonic meter, etc.).

**Characteristic curve correction with polynomial, relative to the Reynolds number**

The correction takes place with a 4th degree polynomial which represents the error curve of the gas meter depending on the Reynolds number.

Error equation: 
$$F_{\text{Re}} = A_{-2} \cdot \frac{1}{\text{Re}^2} + A_{-1} \cdot \frac{1}{\text{Re}} + A_0 + A_1 \cdot \text{Re} + A_2 \cdot \text{Re}^2$$

Reynolds number equation: 
$$\text{Re} = 0,353677 \cdot \frac{Q_b}{DN} \cdot \frac{\rho}{\eta} \quad \wedge \quad \rho = \rho_n \cdot \frac{p}{p_n} \cdot \frac{T_n}{T} \cdot \frac{1}{K}$$

202

Where

$F_{\text{Re}}$  = error curve deviation [%]

$\text{Re}$  = Reynolds number

$A_n$  = constants

$\eta$  = Viscosity

(Menu **AM Viscosity**,  $\eta$  as a constant for natural gas  $\eta = 12 \cdot 10^{-6} \text{ m}^2$ )

The polynomial coefficients  $A_n$  ( $n = -2, -1, 0, 1, 2$ ) are calculated from the measured value pair error  $F_{\text{Re},i}$  and Reynolds number  $\text{Re}_i$ .

Instead of the constant meter factor  $K_V$ , the corrected meter factor  $K_{VK}$  is used for further calculation and/or conversion.

$$K_{VK} = K_V \cdot \left(1 + \frac{F}{100}\right)$$

The polynomial coefficients  $A_n$  are delivered by the manufacturer of the flow rate measuring device (turbine meter, ultrasonic meter, etc.).

### Characteristic curve correction with Straatsma polynomial

This correction functions in a similar manner to the process with flow-rate-related polynomial. However, the Straatsma polynomial correction also includes  $Q_{Vb, \text{max}}$  of the meter that is used. In addition, special Straatsma coefficients are used. The polynomial coefficients  $A_n$  from the manufacturer of the flow rate measuring device (turbine meter, ultrasonic meter, etc.) are also delivered here.

A polynomial function which ideally reflects the curve running through these points is calculated from the polynomial coefficients provided by the manufacturer. The coefficients of the polynomial that the manufacturer has provided must be entered subordinately in Table **GE33** to **GE37** (and **GE38** to **GE41** for the Straatsma correction).

The same function is also provided for reverse operation under

**GF Error curve linearization, reverse flow**. Since the structure is identical, no additional explanation is provided.

5.1.6 GG Flow

GG Flow

Access Line	Designation	Value	Unit	Variable
D	1	Reynolds number	0	<a href="#">reynolds</a>
D	2	Flow velocity	0.000 m/s	<a href="#">vstrom</a>
D	3	Pressure loss	0.000 mbar	<a href="#">plost</a>
T	4	Press. loss coeff.	<input type="text" value="3000"/>	<a href="#">plostKoef</a>
D	5	dynamic pressure	0.000 mbar	<a href="#">staudrk</a>
D	6	Wind speed	0.0 bft	<a href="#">beaufort</a>
D	7	Wind type	Calm	<a href="#">windart</a>

Figure 136: Menu GG Flow

The value from the data sheet of the meter must be entered in **GG04**. The other values are calculated by the ERZ2000-NG.

5.1.7 GH Start-up and shut-down monitoring

GH Start-up and slow-down monitoring

Access Line	Designation	Value	Unit	Variable
D	1	Qm state	At rest	<a href="#">quState</a>
A *	2	Current start-up	0 s	<a href="#">anlauf</a>
A *	3	Cur. slow-down	0 s	<a href="#">auslauf</a>
E *	4	Max.time start-up	<input type="text" value="86400"/>	<a href="#">mZAnlauf</a>
E *	5	Max.time slow-down	<input type="text" value="86400"/>	<a href="#">mZAuslauf</a>
A *	6	Pipe state	unrated	<a href="#">ktkPipe</a>
E *	7	Source	<input type="text" value="OFF"/>	<a href="#">kzoPipe</a>
M	8	Modbus pipe state	0	<a href="#">pipeZu</a>
B	9	Action	<input type="text" value="as alarm"/>	<a href="#">pipeWrk</a>

Figure 137: Menu GH Start-up and shut-down monitoring

The current status is shown in **GH01**. Separate adjustable times for the monitoring of lower flow limit value  $Q_{b,min}$  are adjusted in coordinates **GH04** and **GH05** for the start-up and slow-down. After this time has expired, the  $Q_{b,min}$  alarm is triggered. The release must be activated via contact input or Modbus in **GH07**.

### 5.1.8 HB Energy flow

#### HB Energy flow rate

Access Line	Designation	Value	Unit	Variable
A *	1 Measured value	0.0	kW	Qe
G *	4 Unit		kW	QeDim
B	6 Lower warning limit	<input type="text" value="0.0"/>	kW	QeWGwu
B	7 Upper warning limit	<input type="text" value="300000.0"/>	kW	QeWGwo
G *	30 Format		%. <b>1f</b>	QeFrm
D	31 Min. drag indicator	0.0	kW	QeMn
D	32 Max. drag indicator	0.0	kW	QeMx
D	34 Second mean	0.0	kW	QeSmiw
D	35 Minute mean	0.0	kW	QeMmiw
D	36 Hourly mean	0.0	kW	QeHmiw
D	38 Standard deviation	0.0	kW	QeStAb
D	41 Timestamp min.	19-09-2018 10:50:57		QeMnT
D	42 Timestamp max.	19-09-2018 10:50:57		QeMxT
D	47 Revision mean	0.0	kW	QeRmiw
F	61 Measured value	0.0	kW	iQe

**Figure 138: Menu HB Energy flow**

The energy flow can be checked in this menu. Warnings can be adjusted if limit values are undercut (**HB06**) or exceeded (**HB07**).

All other values are provided strictly for display purposes. A drag pointer indicates the minimum or maximum which arose during the last measurement period. Various average values are also displayed.

Menus **HC Mass flow**, **HD Volumetric flow rate at base conditions**, **HE Uncorrected volumetric flow rate at measurement conditions** and **HF Corrected volumetric flow rate at measurement conditions** are summarized in a representation in the essentially identically arranged **HA Overview**. Menu **HG Component flow rate** also shows the mass flows of the individual components when the respective percentage mass share of the gas components is known. However, no warning limits are adjustable.

#### Note

The formats of the respective flows (**HB30**) are adjustable separately.

5.1.9 OO Extra counter

**OO Extra counter 1 X7-1,2**

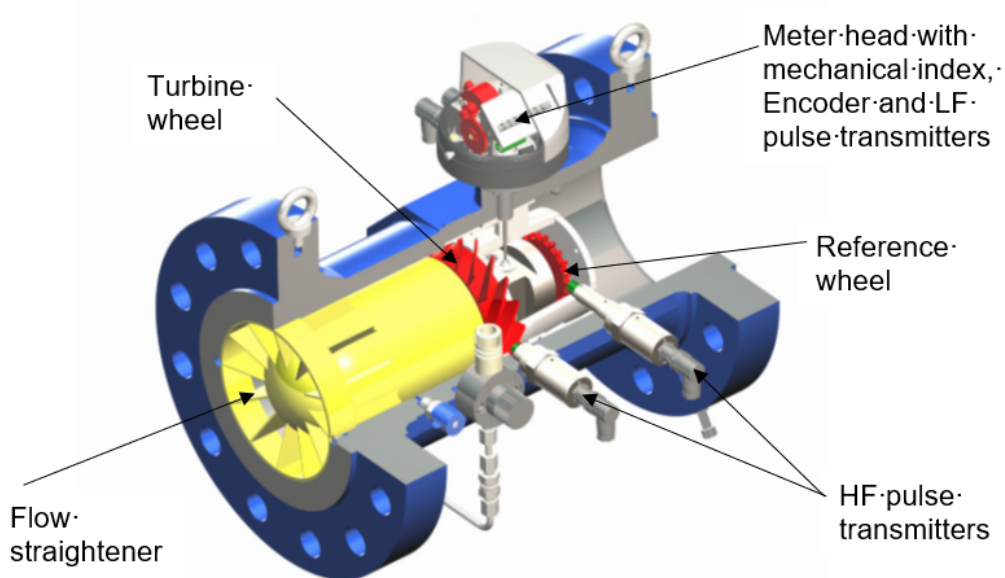
Access	Line	Designation	Value	Unit	Variable
I	1	Input pulses	0	pulses	<a href="#">kfkCnt1</a>
N	8	Integer part	0	[]	<a href="#">ez1</a>
N	9	Fraction part	.000000	[]	<a href="#">ez1R</a>
B	10	Weighting	<input type="text" value="0"/>		<a href="#">ekv1</a>
B	11	Unit	<input type="text" value=""/>		<a href="#">ez1Dim</a>
B	12	Symbol	<input type="text" value="Sonder1"/>		<a href="#">ez1Symbol</a>

**Figure 139: Menu OO Extra counter 1**

Free inputs (up to 8) can be assigned with signals in a similar manner to the custody-transfer-relevant measuring inputs. These must be treated analogously to all other frequency inputs (see *chapter 2.7.13 NL Frequency input 1*) in regard to their settings.

## 5.2 Turbine meter

The operating method of turbine meters is based on the measurement of gas speed with a turbine wheel. In the process, the speed of the turbine (approximately) within the measuring range ( $Q_{\min}$  -  $Q_{\max}$ ) is proportional to the mean gas speed and thus the flow rate. The number of rotations, therefore, is a measurement for the gas volume flowing through.



**Figure 140: Turbine meter sectional drawing**

The rotational movement of the turbine wheel is transferred after reduction to the meter head in which the frequency is normally scanned redundantly with two sensors and transmitted as a LF signal. The meter can be optionally equipped with an encoder that can also transmit flow information.

In principle, the further processing of low-frequency pulses independently of the measuring principle, can also be handled in a comparable manner by rotary piston gas meters, vortex meters or other flow measuring devices with a frequency output.



### 5.2.1 EC Billing mode

#### EC Billing mode

Access Line	Designation	Value	Unit	Variable
D	1	Current text	(...)	actAMklar
A *	2	Current bill. mode	0	actAM
A *	3	Bill. mode control -> NT01	-----	bin AMQuelle
E *	4	Bill. mode select.	4 cont. 4*BM	AMCtrl
E *	5	Assignment	Edit	AMMW_Mod
E *	6	Threshold BM1->2	50	bin AM1_2Val
E *	7	Threshold BM2->3	100	bin AM2_3Val
E *	8	Threshold BM3->4	150	bin AM3_4Val
B	9	Clear text BM1	AM1	AM1klar
B	10	Clear text BM2	AM2	AM2klar
B	11	Clear text BM3	AM3	AM3klar
B	12	Clear text BM4	AM4	AM4klar
A *	13	Contact 1 for BM	OFF	AMtk1
A *	14	Contact 2 for BM	OFF	AMtk2
A *	15	Contact 3 for BM	OFF	AMtk3
A *	16	Contact 4 for BM	OFF	AMtk4
E *	17	Source BM contact 1	OFF	kzoAMtk1
E *	18	Source BM contact 2	OFF	kzoAMtk2
E *	19	Source BM contact 3	OFF	kzoAMtk3
E *	20	Source BM contact 4	OFF	kzoAMtk4
S	21	BM at revision	unchanged	amRevMod
B	22	BM0 suppression	No	AM0Cut
D	23	No. bill.modes	5	anzAMB

Enter Cancel Load defaults Refresh

Figure 141: Menu EC Billing mode

The ERZ2000-NG has different totalizer sets which can fulfill different tasks, e.g.:

- Some gas flow meters can determine volume flow forwards and backwards with the same accuracy. Then, the totalizer can be used in forward and backward operation:
  - Filling and emptying of a gas accumulator
  - With changeover of lines of different pressures (e.g. changeover of a line with low pressure to a line with higher pressure), temporary return flow can arise.
- The flow rate is determined in different lines.
  - There is a – mostly larger – line with corresponding gas totalizer for winter operation and an additional – usually smaller – line with some gas totalizer for summer operation.
  - Gas from different sources / providers is supplied to the downstream network.

Various billing modes can be adjusted in coordinate **EC04**:

- Bill.mode 1
- Bill.mode 2
- Bill.mode 3
- Bill.mode 4
- 1 ctc. 2\*BM
- 2 ctc. 2\*BM
- 2 ctc. 4\*BM
- 4 ctc. 4\*BM
- Modbus
- Meas.->2BM
- Meas.->3BM
- Meas.->4BM
- Vo Direction
- DZU Direction
- Flow direction
- GC1/GC2

With selection of the first 4 points (billing mode 1, 2, 3, 4), the respective billing mode is assigned directly.

It is possible to assign different billing modes via the contacts and different selection points:

- 1 ctc. 2\*BM

Ctc 1 open	⇒	Billing mode 1
Ctc 1 closed	⇒	Billing mode 2

- 2 ctc. 2\*BM

Ctc 1 open / Ctc 2 closed	⇒	Billing mode 1
Ctc 1 closed / Ctc 2 open	⇒	Billing mode 2
Ctc 1 open / Ctc 2 open	⇒	No assignment or undefined billing mode
Ctc 1 closed / Ctc 2 closed	⇒	No assignment or undefined billing mode

For example, 2 valves can be assigned contacts in 2 routes (gas lines) here. Only when both valves are in one clear direction, e.g. Valve 1 closed and Valve 2 open,

Route 1 is assigned (V1 closed, V2 open Route 2). All positions of the valves between them, e.g. which can be provided for changeover, are not assigned to any billing mode.

The other contact options can be assigned in a similar manner:

- 2 ctc. 4\*BM

Ctc 1 open	Ctc 2 closed	⇒	Billing mode 1
Ctc 1 closed	Ctc 2 closed	⇒	Billing mode 2
Ctc 1 open	Ctc 2 open	⇒	Billing mode 3
Ctc 1 closed	Ctc 2 open	⇒	Billing mode 4

209

- 4 ctc. 4\*BM

Analog, see above.

- Meas.->2 BM
- Meas.->3 BM
- Meas.->4 BM

Similar assignments can be assigned to a measurement here. As an example, the temperature is selected here. This selection takes place in coordinate **EC05 Assignment** by activating edit.

In the process, the **thresholds** should be entered in coordinates **EC06 to EC08**. The value settings in *Figure 141: Menu EC Billing mode* **Fehler! Verweisquelle konnte nicht gefunden werden.** produce:

Temperature < 50°C	⇒	Billing mode 1
50°C < Temperature < 100°C	⇒	Billing mode 2
100°C < Temperature < 150°C	⇒	Billing mode 3
Temperature > 150°C	⇒	Billing mode 4

- Vo Direction

If "rev. permitted" is adjusted in coordinate **LN16 Vo Direction mode**, the Vo Direction can be used like a contact for switching to the billing modes.

- DZU Direction
- Flow direction

The DZU Direction and flow direction can be used in the same manner as the Vo Direction.

- GC1/GC2

GC1/GC2 can be used, for example, if two different gas analysis devices are in use, e.g. a full analysis device like the PGC9300 and a calorific value measuring device like an EMC. Then, the practicable evaluation method is adjusted for this device, AGA 8 for the PGC and GERG 88 for the EMC.

GC1/GC2 can be used, for example, to switch from billing mode 1 for full analysis to billing mode 2 for calorific value determination.

- Modbus

A changeover to one of the 4 billing modes can also take place via Modbus. Coordinate **IJ36 Route** is used for this purpose to set Register 5066 to a value of 1, 2, 3 or 4 via the Modbus address. Then, a different value is not assigned or added to an undefined billing mode.

In the process, the two first billing modes correspond to traditional Routes 1 and 2 and can be controlled with the contact inputs (**EC17**, **EC18**).

The billing modes are assigned names in plain text, e.g. Summer operation, in **EC09** to **EC12**.

**EC13** to **EC16** indicate the switching positions (contact input).

**LN Original totalizer, encoder totalizer terminal X4 or X9**

Access Line	Designation	Value	Unit	Variable
I	2	Current tot.reading	.000000 m3	<a href="#">voZw</a>
D	3	Last tot.reading	.000000 m3	<a href="#">voZwl</a>
I	4	Vo tot.status	-1	<a href="#">vost</a>
D	5	Overflow	.000000 m3	<a href="#">voOvfl</a>
D	6	Max. cycle quantity	.000000 m3	<a href="#">voZykMax</a>
D	7	Vo direction	Uncertain	<a href="#">voDirec</a>
D	8	Current time stamp	0 s	<a href="#">voStamp</a>
D	9	Last time stamp	0 s	<a href="#">voStamp1</a>
J	10	Manufacturer		<a href="#">voManuf</a>
J	11	Device type		<a href="#">voGerTp</a>
J	12	Serial number		<a href="#">voSerNr</a>
J	13	Vo year of constr.		<a href="#">voBaujahr</a>
J	14	Software version		<a href="#">voSoftw</a>
J	15	Vo tot. unit		<a href="#">voEinheit</a>
E *	16	Vo direction mode	Rev. prohibited ▾	<a href="#">voDirMod</a>
D	17	Running Vo timeout	0 s	<a href="#">voTimCnt</a>
B	18	Vo timeout	10 s	<a href="#">voTimeout</a>
D	19	No. of telegrams	0	<a href="#">voTqAnz</a>
D	20	Vo cycle quantity	m3	<a href="#">voZykMng</a>
D	21	DSFG status	Default value	<a href="#">voEstt</a>
E *	22	Encoder-ID input	automatically ▾	<a href="#">voTpIn</a>
E *	23	Manufacturer	RMG	<a href="#">vhManuf</a>
E *	24	Device type	ENCO-F/M	<a href="#">vhGerTp</a>
E *	25	Serial number	0	<a href="#">vhSerNr</a>
B	26	Safety margin	8	<a href="#">zuschlag</a>

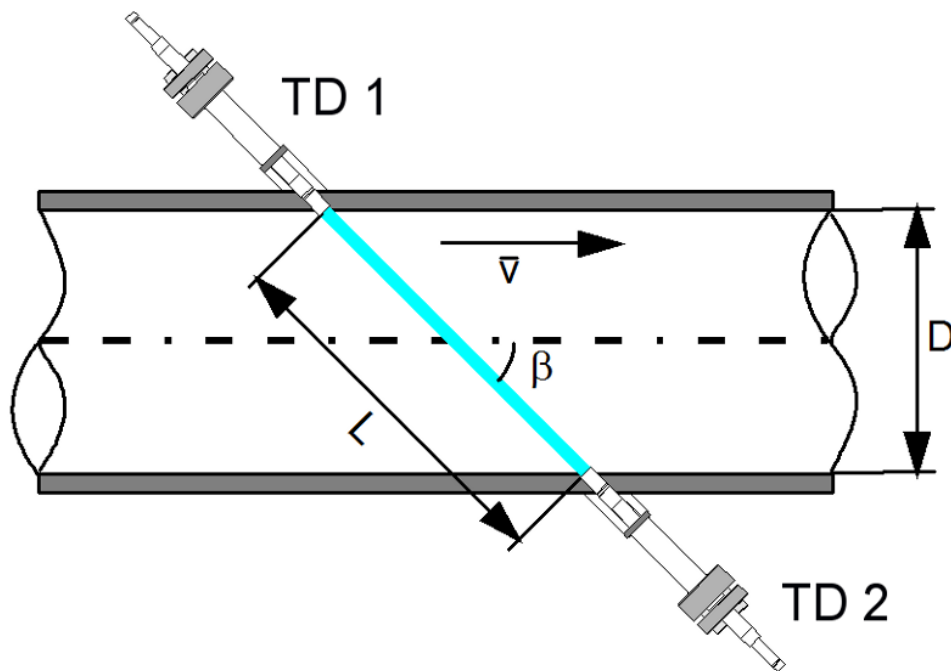
Enter Cancel Load defaults Refresh

**Figure 142: Menu LN Original totalizer**

The menu is intended primarily for display purposes. An automatic entry of the type plate data is made in **LN10 Manufacturer** to **LN15 Vo tot. unit**, as long as the transmitter provides this data in the frame of the telegram defined for this purpose. The behavior with a Vo transducer rotating in reverse is defined in coordinate **LN16 Vo direction mode**. The options "rev prohibited" and "rev permitted" are available.

### 5.3 Ultrasonic gas meter

Figure 143: 2 Transducers form a path for the measurement shows the basic principle. Transducers TD1 and TD2 are available for the measurement and form a measuring path with the distance  $L$ . An ultrasonic pulse is transmitted – with flow – on the measuring path back sensor TD1 to transducer TD2 faster than vice versa. This is caused physically by the frequency pulling with the flow of the gas; the arrow above the  $\vec{v}$  indicates the flow direction.



**Figure 143: 2 Transducers form a path for the measurement**

The run times of TD1 to TD2 ( $:= t_{TD12}$ ) and from TD2 to TD1 ( $:= t_{TD21}$ ) are calculated according to the following formula:

$$t_{TD12} = \frac{L}{c_0 + \vec{v} \cdot \cos \beta} \quad \wedge \quad t_{TD21} = \frac{L}{c_0 - \vec{v} \cdot \cos \beta}$$

These run times of the ultrasonic pulse are determined with the ultrasonic electronics. They can be used to determine the average speed  $\vec{v}$  along the measuring path:

$$\vec{v} = \frac{L^2}{2 \cdot d} \frac{\Delta t}{t_{TD12} \cdot t_{TD21}}$$

Where:

$\bar{v}$	Average flow speed
$c_0$	Velocity of sound
$\beta$	Path angle to the pipe
$L$	Path length
$d$	= D for Figure 143: 2 Transducers form a path for the measurement. An analog value arises for measuring paths other than the mean path.

In order to consider the flow profile, particularly an asymmetrical or heavily swirling flow, a total of 6 paths are measured on 3 levels with ultrasonic meters from RMG. The 3 levels can be derived mathematically with an integration process, called Gauss integration.

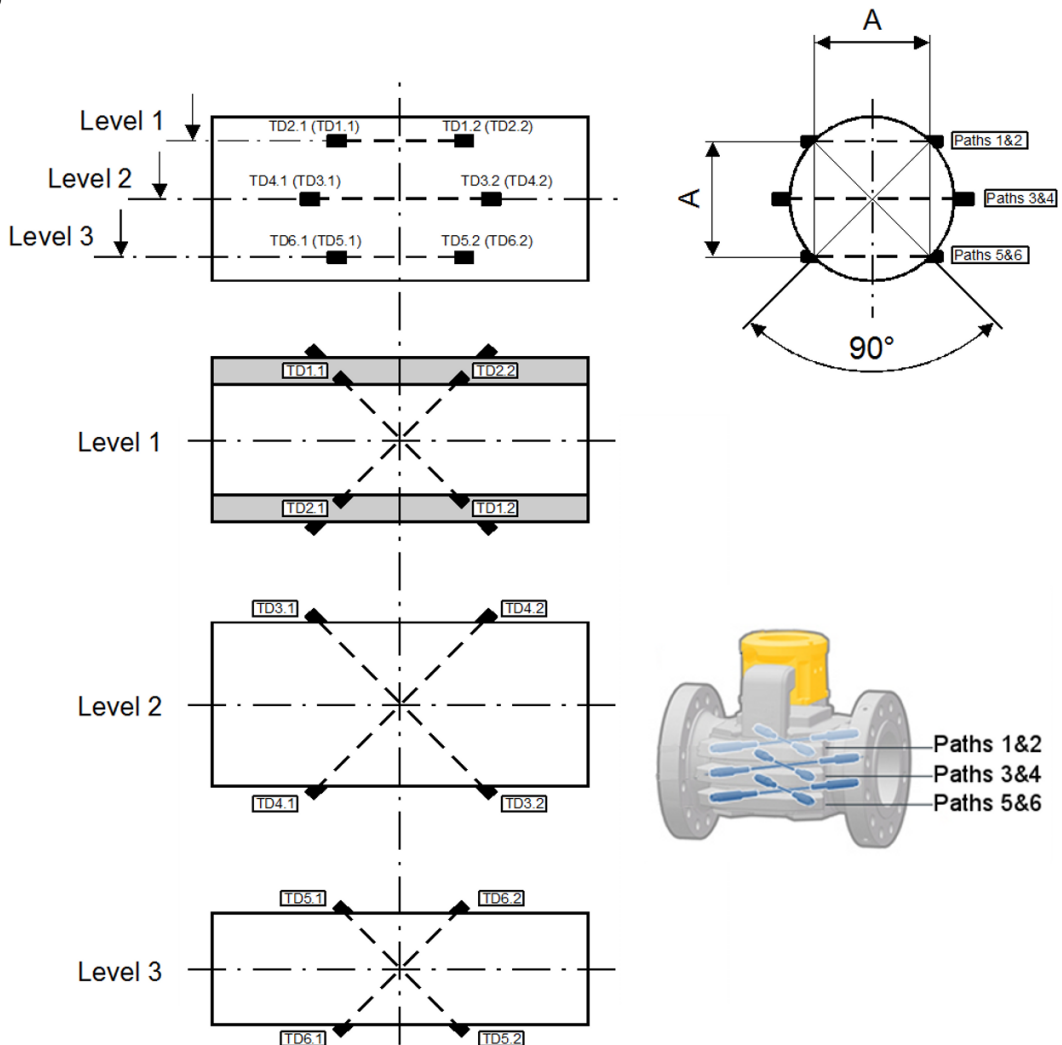


Figure 144: Ultrasonic measuring paths

Other manufacturers have, in part, implemented different path arrangements; however, the further expansion is normally carried out in a similar manner.

The individual mean path speeds are weighted and add up according to the Gauss quadrature. Multiplication by the pipe cross-section produces the volume flow.

214

### Quality of the installation situation

Ultrasonic meters provide parameters which permit an assessment of the installation situation. If the values are in the specified ranges, good measuring conditions can be assumed. If the values are outside of the specified ranges, disturbed flow conditions could impair the measuring accuracy.

### Turbulence

Based on the prevalent flow, particularly the turbulence, characteristic scattering occurs (variance  $\sigma_i$ ) in determining the individual path speeds ( $i = 1..6$ ; number of ultrasonic measuring paths) which can permit an evaluation of the installation conditions. The average turbulence ( $Tu_i$ ) over the ultrasonic measuring path is calculated:

$$\sigma_i = \sqrt{\frac{1}{N-1} \sum_{j=1}^N (v_{j,i} - \bar{v}_i)^2} \quad \wedge i = 1..6; N = 20$$

$$Tu_i = \frac{\sigma_i}{|\bar{v}_i|}$$

Where:

$\bar{v}_i$	The average speed over time along the ultrasonic measuring path
$v_{j,i}$	Flow speed along the ultrasonic measuring path
$N$	= 20; number of measurements for the turbulence calculation

Typical values for very good flow conditions for middle paths are at 2-3 %; the turbulence for outside paths increases to up to 4 %. If these values above 10 %, disturbed flow conditions could impair the measuring accuracy. The turbulence calculation is switched off with the lowest speeds.



### Profile and symmetry factory

With a fully developed flow, the middle paths (3 + 4) have the highest prevailing speed, the two outside paths (1 + 2; 5 + 6) have about the same speed. The profile factor (*PF*) is typically between 1.05 and 1.20; with values below 1.00 or above 1.50, the flow conditions must be checked.

$$PF = \frac{2 \cdot (\bar{v}_3 + \bar{v}_4)}{(\bar{v}_1 + \bar{v}_2) + (\bar{v}_5 + \bar{v}_6)}$$

---

 215
 

---

The symmetry factor (*SY*) is normally 0.90 – 1.10; with values below 0.75 or above 1.25, the measuring conditions must be checked.

$$SY = \frac{(\bar{v}_1 + \bar{v}_2)}{(\bar{v}_5 + \bar{v}_6)}$$

### Meter performance

This value (*MP*) indicates whether the speeds of all measuring paths could be determined and incorporated into the flow rate calculation. Calculation takes place for the last 20 measurements (identical to the number for turbulence).

$$MP = \frac{\sum_{j=1}^{100} \sum_{i=1}^6 1 \quad (\wedge v_{j,i} = ok) \quad \vee \quad 0 \quad (\wedge v_{j,i} \neq ok)}{600}$$

The value is a maximum of 100%; under normal conditions it is above 95%. Since 2 measuring paths can fail before a 6-path USM loses its calibrated accuracy, the value may temporarily decrease to 66%; if the failure is due to a defective transducer, an immediate repair of the affected transducer of the failed measuring path must be sought.

### 5.3.1 GJ Body compensation

#### GJ Body compensation

Access Line	Designation	Value	Unit	Variable	
A *	1	Correction effect	<b>100.000000</b>	%	<a href="#">bcmpRes</a>
E *	5	Reference pressure	3.601325	MPa	<a href="#">bcmpPr</a>
E *	6	Young's modulus	200.00	GPa	<a href="#">bcmpE</a>
E *	7	Outside diameter	273.600	mm	<a href="#">bcmpDO</a>
E *	8	Inside diameter	247.520	mm	<a href="#">bcmpDI</a>
A *	9	Wall thickness	<b>0.000</b>	mm	<a href="#">bcmpd</a>
E *	10	Reference temp.	17.8125	°C	<a href="#">bcmpTr</a>
E *	11	therm.expans.coef.	10.900	10 <sup>-6</sup> /°C	<a href="#">bcmpAlp</a>
E *	12	Correction method	OFF		<a href="#">bcmpMod</a>
E *	13	calculation method	ISO TC30/SC5N169		<a href="#">bcmpClc</a>

**Figure 145: Menu GJ Body compensation**

In menu **GJ Body compensation**, an expansion of the meter housing and thus a change to the inside diameter can be considered as a function of the temperature and pressure. Normally, these values are so small that they have no practical implementation (for example, the MID doesn't request for this compensation).

#### Note

If GJ Correction mode is set to "off", no correction takes place – this is the necessary setting for the German approval requirement.

### 5.3.2 UA Ultrasonic volume transmitter

#### UA Ultrasonic transmitter

Access Line	Designation	Value	Unit	Variable
B	1	No. samples for SV	140	<a href="#">EWMAnz</a>
E *	2	Number of paths	6	<a href="#">pfadAnz</a>
E *	3	zero point noise	0.000	m/s <a href="#">vwUg</a>
E *	4	kv factor	1.00000	<a href="#">usKv</a>
E *	5	Allowed brok.paths	2	<a href="#">pfadtotMx</a>
E *	7	Measurem. quality	70	% <a href="#">MWQ</a>
E *	8	Communic. quality	95	% <a href="#">MWC</a>
B	9	VOS upper limit	500.00000	m/s <a href="#">usVosMx</a>
B	10	VOS lower limit	150.00000	m/s <a href="#">usVosMn</a>
A *	11	Velocity of sound	<b>0.00000</b>	m/s <a href="#">usVos</a>
A *	12	Direction	<b>Direction 1</b>	<a href="#">uszDirec</a>
D	13	IGM startup	0	<a href="#">iqmStartUp</a>
A *	14	Broken path	<b>0</b>	<a href="#">pfadtot</a>
D	16	IGM cycle quantity	.000000	m3 <a href="#">usZykMng</a>
I	17	Timeout IGM 1	0	<a href="#">iqm1To</a>
I	18	Timeout IGM 2	0	<a href="#">iqm2To</a>
I	19	Timeout IGM 3	0	<a href="#">iqm3To</a>
I	20	Timeout IGM 4	0	<a href="#">iqm4To</a>
Q	21	IGM Reset	0	<a href="#">iqmReset</a>
E *	22	max. VOS deviation	3.000	% <a href="#">mxVosAbw</a>
D	23	Path status	00000000	<a href="#">pfvOvw</a>
X	24	SV reset	No	<a href="#">EWreset</a>
D	25	SV status	Invalid	<a href="#">aktEWStat</a>
D	26	SV range	0	<a href="#">aktEWBer</a>
D	27	SV valid	0	<a href="#">ewValid</a>
D	28	SV set	0	<a href="#">ewGesetzt</a>
D	29	SV not valid	0	<a href="#">ewNotVal</a>
D	30	VOS status	00000000	<a href="#">pfvosOvw</a>
B	35	show VOS error	No	<a href="#">errVos</a>
S	36	IGM timeout period	20	*10 ms <a href="#">iqmSllTo</a>
S	37	def.C-Mode	Yes	<a href="#">defCMod</a>

Figure 146: Menu UA Ultrasonic volume transmitter

This and the following menu define the operation of an ultrasonic meter (IGM), which only assumes a small part of the signal evaluation and further processing. The ERZ2000-NG assumes the majority of these tasks.

The sensor signals of the IGM measuring heads are connected via a Modbus connection directly to the flow computer in this operating mode. The interface provided for this purpose on the flow computer is COM 1. If the software function is enabled, the ultrasonic controller is activated; no additional hardware is required.

When one of the 4 possible device versions has been selected (ERZ2004 USC, ERZ2104 USC, ERZ2002 USC or ERZ2102 USC), additional function units must be considered.

In recent years, some new ultrasonic meters have been introduced to the market, with which this further processing is an integral component of the electronic evaluation. Therefore, refer to the manuals of these meters for the description of these functionalities. A more elaborate description of the meaning of the individual fields for the IGM is provided in the separate documentation ERZ\_2000\_USC\_Details.

218

### 5.3.3 UB USZ Reynolds correction

#### UB Reynolds correction

Access	Line	Designation	Value	Unit	Variable
A *	1	Re corr. factor	0.00000		<a href="#">kfRe</a>
E *	10	Reynolds corr.	No ▾		<a href="#">ReKorr</a>
E *	21	Coeff. A dir. 1	1.00000		<a href="#">KA_R1</a>
E *	22	Coeff. B dir. 1	0.00000		<a href="#">KB_R1</a>
E *	23	Coeff. C dir. 1	1.00000		<a href="#">KC_R1</a>
E *	31	Coeff. A dir. 2	1.00000		<a href="#">KA_R2</a>
E *	32	Coeff. B dir. 2	0.00000		<a href="#">KB_R2</a>
E *	33	Coeff. C dir. 2	1.00000		<a href="#">KC_R2</a>

Enter Cancel Load defaults Refresh

Figure 147: Menu UB USZ Reynolds correction

Even a fully-developed speed profile changes with the Reynolds number, particularly with small Reynolds numbers. This applies not only to the "big" change with a transition from laminar to turbulent flow, but also the lower turbulent range beyond it. The correction is described in *chapter 5.1.5 GE Error curve linearisation, forward flow*.

This correction is – if necessary – implemented by new ultrasonic flow rate meters and does not have to be used again here. It can be used with the IGM; refer to *chapter 5.3.2 UA Ultrasonic volume transmitter*.

### 5.3.4 UC Base correction

#### UC Base correction

Access Line	Designation	Value	Unit Variable
A *	1 base corr. factor	0.00000	% kfGr
E *	10 Base correction	No	GrundKrr
E *	21 Coeff. A-2 dir. 1	0.00000e+000	PGR1m2
E *	22 Coeff. A-1 dir. 1	0.00000e+000	PGR1m1
E *	23 Coeff. A0 dir. 1	0.00000e+000	PGR1p0
E *	24 Coeff. A1 dir. 1	0.00000e+000	PGR1p1
E *	25 Coeff. A2 dir. 1	0.00000e+000	PGR1p2
E *	31 Coeff. A-2 dir. 2	0.00000e+000	PGR2m2
E *	32 Coeff. A-1 dir. 2	0.00000e+000	PGR2m1
E *	33 Coeff. A0 dir. 2	0.00000e+000	PGR2p0
E *	34 Coeff. A1 dir. 2	0.00000e+000	PGR2p1
E *	35 Coeff. A2 dir. 2	0.00000e+000	PGR2p2

Enter Cancel Load defaults Refresh

Figure 148: Menu UC Base correction

This correction is – if necessary – implemented by new ultrasonic flow rate meters and does not have to be used again here. It can be used with the IGM; refer to chapter 5.3.2 UA Ultrasonic volume transmitter.

### 5.3.5 UD Err.curve correction

#### UD Err.curve correction

Access Line	Designation	Value	Unit Variable
A *	1 err.crv.corr.fact.	0.00000	% kfk1
E *	10 Error curve corr.	No	KeliKrr
E *	21 Coeff. A-2 dir. 1	0.00000e+000	PKR1m2
E *	22 Coeff. A-1 dir. 1	0.00000e+000	PKR1m1
E *	23 Coeff. A0 dir. 1	0.00000e+000	PKR1p0
E *	24 Coeff. A1 dir. 1	0.00000e+000	PKR1p1
E *	25 Coeff. A2 dir. 1	0.00000e+000	PKR1p2
E *	31 Coeff. A-2 dir. 2	0.00000e+000	PKR2m2
E *	32 Coeff. A-1 dir. 2	0.00000e+000	PKR2m1
E *	33 Coeff. A0 dir. 2	0.00000e+000	PKR2p0
E *	34 Coeff. A1 dir. 2	0.00000e+000	PKR2p1
E *	35 Coeff. A2 dir. 2	0.00000e+000	PKR2p2

Enter Cancel Load defaults Refresh

Figure 149: Menu UD Err.curve correction

This correction is – if necessary – implemented by new ultrasonic flow rate meters and does not have to be used again here. It can be used with the IGM; refer to *chapter 5.3.2 UA Ultrasonic volume transmitter*.

### 5.3.6 UE Effects of correct.

#### UE Effects of correct.

Access Line	Designation	Value	Unit	Variable	
A *	1	Velo, uncorr.	0.000	m/s	<a href="#">vwOrg</a>
A *	2	Velo, Re-corr.	0.000	m/s	<a href="#">vwRe</a>
A *	3	Velo, basecorr.	0.000	m/s	<a href="#">vwGr</a>
A *	4	Velo, errcrv.corr.	0.000	m/s	<a href="#">vwKl</a>
A *	5	Flow, uncorr.	0.00	m3/h	<a href="#">QoOrg</a>
A *	6	Flow, Re-corr.	0.00	m3/h	<a href="#">QoRe</a>
A *	7	Flow, basecorr.	0.00	m3/h	<a href="#">QoGr</a>
A *	8	Flow, errcrv.corr.	0.00	m3/h	<a href="#">QoKl</a>
A *	9	Re, uncorr.	0		<a href="#">ReOrg</a>
A *	10	Re, Re-corr.	0		<a href="#">ReRe</a>
A *	11	Re, basecorr.	0		<a href="#">ReGr</a>
A *	12	Re, errcrv.corr.	0		<a href="#">ReKl</a>

Refresh

**Figure 150: Menu UE Effects of corrections**

This menu shows the effects of the prior corrections. Since these corrections are – if necessary – implemented with new ultrasonic flow rate meters, normally "nothing" has to be monitored here. It can be seen with the IGM; refer to *chapter 5.3.2 UA Ultrasonic volume transmitter*.

5.3.7 UF ID display IGM 1

UF ID display IGM 1

Access Line	Designation	Value	Unit	Variable
J 1	Identification	0		<a href="#">igmId1</a>
J 2	Version			<a href="#">igmVer1</a>
J 3	Checksum			<a href="#">igmChk1</a>
J 4	Relay delay time	0	ms	<a href="#">igmRDT1</a>
J 5	Batches	0		<a href="#">igmBtch1</a>
J 6	Pulses	0		<a href="#">igmPls1</a>
J 7	FIFO len	0		<a href="#">igmFif1</a>
J 8	V min.	0.00	m/s	<a href="#">igmVmn1</a>
J 9	V max.	0.00	m/s	<a href="#">igmVmx1</a>
J 10	C min.	0.00	m/s	<a href="#">igmCmn1</a>
J 11	C max.	0.00	m/s	<a href="#">igmCmx1</a>
J 12	Amplitude high	0.00		<a href="#">igmAmpH1</a>
J 13	Amplitude low	0.00		<a href="#">igmAmpL1</a>
J 14	Signal high	0.00	dB	<a href="#">igmSigH1</a>
J 15	Signal low	0.00	dB	<a href="#">igmSigL1</a>
E *	16 Sensor No. 1.1	<input type="text" value="00000000"/>		<a href="#">sensono11</a>
E *	17 Sensor No. 1.2	<input type="text" value="00000000"/>		<a href="#">sensono12</a>
J 18	Path 1 length	0.000	mm	<a href="#">pfLen1</a>
J 19	Path 1 Axial len.	0.000	mm	<a href="#">pfAbstd1</a>
J 20	Path 1 C theo.	0.000	m/s	<a href="#">pfCtheo1</a>
J 21	Dead time path 1	0.000	us	<a href="#">pfTotZt1</a>
J 22	F transmit path 1	0.000	Hz	<a href="#">pfTrans1</a>
J 23	F receive path 1	0.000	Hz	<a href="#">pfRecve1</a>
J 24	Measurements P1	0.000		<a href="#">igmAvc01</a>
E *	25 Sensor No. 2.1	<input type="text" value="00000000"/>		<a href="#">sensono21</a>
E *	26 Sensor No. 2.2	<input type="text" value="00000000"/>		<a href="#">sensono22</a>
J 27	Path 2 length	0.000	mm	<a href="#">pfLen2</a>
J 28	Path 2 Axial len.	0.000	mm	<a href="#">pfAbstd2</a>
J 29	Path 2 C theo.	0.000	m/s	<a href="#">pfCtheo2</a>
J 30	Dead time path 2	0.000	us	<a href="#">pfTotZt2</a>
J 31	F transmit path 2	0.000	Hz	<a href="#">pfTrans2</a>
J 32	F receive path 2	0.000	Hz	<a href="#">pfRecve2</a>
J 33	Measurements P2	0.000		<a href="#">igmAvc11</a>

Enter
Cancel
Load defaults
Refresh

**Figure 151: Menu UF ID display IGM 1**

These functions provide detailed information about the IGM ultrasonic transmitter, its sensors and their behavior. An exact description of the meaning of the individual fields is provided in the separate documentation

ERZ\_2000\_USC\_Details.

The same menus are also provided for the IGM2, IGM3 and IGM4.

### 5.3.8 UJ Path 1

#### UJ Path 1

Access Line	Designation	Value	Unit	Variable
A *	1	Corrected velocity	0.000	m/s <a href="#">usVk1</a>
D	2	Status	Source value	<a href="#">usSt1</a>
I	3	Genuine velocity	0.000	m/s <a href="#">usV1</a>
D	4	Substitute value	0.000	m/s <a href="#">usEW1</a>
I	5	Measurem. quality	0	% <a href="#">usMWQ1</a>
I	6	Communic. quality	0	% <a href="#">usMWC1</a>
I	7	VOS	0.00000	m/s <a href="#">usVos1</a>
D	8	Comparison VOS	0.00000	m/s <a href="#">vqVos1</a>
D	9	VOS-deviation	0.000	% <a href="#">usVosDf1</a>
D	10	Path status	Okay	<a href="#">usPfv1</a>
D	11	Path VOS status	Okay	<a href="#">usPfos1</a>
I	15	AGC up 1	0	<a href="#">usAgcU1</a>
I	16	AGC down 1	0	<a href="#">usAgcD1</a>
E *	31	Weighting	<input type="text" value="1.00000"/>	<a href="#">usW1</a>
E *	32	Corr. fact. dir. 1	<input type="text" value="1.00000"/>	<a href="#">usR1K1</a>
E *	33	Corr. fact. dir. 2	<input type="text" value="1.00000"/>	<a href="#">usR2K1</a>
E *	34	Mapping	<input type="text" value="10"/>	<a href="#">usMap1</a>

Figure 152: Menu UJ Path 1

This menu shows details of the display and parameterization for measuring path 1 of an IGM Ultrasonic meter; therefore, refer to *chapter 5.3.2 UA Ultrasonic volume transmitter*.

The following menus have the same layout for measuring paths 2, 3, 4, 5, 6, 7 and 8.

### 5.3.9 VA Current velocity of gas

#### VA Current velocity of gas

Access Line	Designation	Value	Unit	Variable
D	1	Gas velocity	0.000	m/s <a href="#">gasVel</a>
I	11	V gas	0.000	m/s <a href="#">pfadv1</a>
I	12	V gas	0.000	m/s <a href="#">pfadv2</a>
I	13	V gas	0.000	m/s <a href="#">pfadv3</a>
I	14	V gas	0.000	m/s <a href="#">pfadv4</a>
I	15	V gas	0.000	m/s <a href="#">pfadv5</a>
I	16	V gas	0.000	m/s <a href="#">pfadv6</a>
I	17	V gas	0.000	m/s <a href="#">pfadv7</a>
I	18	V gas	0.000	m/s <a href="#">pfadv8</a>

Figure 153: Menu VA Current velocity of gas



The flow speed is determined along the measuring paths. This menu shows these individually and as a mean value for measuring paths 1-8 of an IGM Ultrasonic meter; therefore, refer to *chapter 5.3.2 UA Ultrasonic volume transmitter*.

### 5.3.10 VB Speed of sound

#### VB Speed of sound

Access	Line	Designation	Value	Unit	Variable
I	1	SoS mean	0.000	m/s	<a href="#">vosDzu</a>
D	2	Hourly mean SoS path	0.000	m/s	<a href="#">vosMiw</a>
I	11	Speed of sound	0.000	m/s	<a href="#">pfadvos1</a>
I	12	Speed of sound	0.000	m/s	<a href="#">pfadvos2</a>
I	13	Speed of sound	0.000	m/s	<a href="#">pfadvos3</a>
I	14	Speed of sound	0.000	m/s	<a href="#">pfadvos4</a>
I	15	Speed of sound	0.000	m/s	<a href="#">pfadvos5</a>
I	16	Speed of sound	0.000	m/s	<a href="#">pfadvos6</a>
I	17	Speed of sound	0.000	m/s	<a href="#">pfadvos7</a>
I	18	Speed of sound	0.000	m/s	<a href="#">pfadvos8</a>
D	21	Deviation SoS	0.000	%	<a href="#">abwvos1</a>
D	22	Deviation SoS	0.000	%	<a href="#">abwvos2</a>
D	23	Deviation SoS	0.000	%	<a href="#">abwvos3</a>
D	24	Deviation SoS	0.000	%	<a href="#">abwvos4</a>
D	25	Deviation SoS	0.000	%	<a href="#">abwvos5</a>
D	26	Deviation SoS	0.000	%	<a href="#">abwvos6</a>
D	27	Deviation SoS	0.000	%	<a href="#">abwvos7</a>
D	28	Deviation SoS	0.000	%	<a href="#">abwvos8</a>
D	31	Avrg. deviation SoS	0.0000	%	<a href="#">abwvos1m</a>
D	32	Avrg. deviation SoS	0.0000	%	<a href="#">abwvos2m</a>
D	33	Avrg. deviation SoS	0.0000	%	<a href="#">abwvos3m</a>
D	34	Avrg. deviation SoS	0.0000	%	<a href="#">abwvos4m</a>
D	35	Avrg. deviation SoS	0.0000	%	<a href="#">abwvos5m</a>
D	36	Avrg. deviation SoS	0.0000	%	<a href="#">abwvos6m</a>
D	37	Avrg. deviation SoS	0.0000	%	<a href="#">abwvos7m</a>
D	38	Avrg. deviation SoS	0.0000	%	<a href="#">abwvos8m</a>

Refresh

**Figure 154: Menu VB Speed of sound**

In addition to the flow speed, the velocity of sound along the measuring paths can be determined. This menu shows these individually and as a mean value for measuring paths 1-8 of an IGM Ultrasonic meter; therefore, refer to *chapter 5.3.2 UA Ultrasonic volume transmitter*.

### 5.3.11 VC Ultrasonic profile

#### VC Ultrasonic profile of velocities

Access Line	Designation	Value	Unit	Variable
D 9	Swirl	0.000	%	<a href="#">Swirl</a>
D 10	Double swirl	0.000	%	<a href="#">DSwirl</a>
D 11	Asymmetry	0.000	%	<a href="#">Asym</a>
D 12	Cross flow	0.000	%	<a href="#">Cross</a>
D 13	PFY1	0.000		<a href="#">pfy1</a>
D 14	PFY2	0.000		<a href="#">pfy2</a>
D 15	PFY	0.000		<a href="#">pfy</a>
D 16	PFY31	0.000		<a href="#">pfy31</a>
D 17	PFY35	0.000		<a href="#">pfy35</a>
D 18	PFY42	0.000		<a href="#">pfy42</a>
D 19	PFY46	0.000		<a href="#">pfy46</a>
D 20	PFX	0.000		<a href="#">pfx</a>
D 21	PFX12	0.000		<a href="#">pfx12</a>
D 22	PFX56	0.000		<a href="#">pfx56</a>
D 23	PF-Sym-X	0.000		<a href="#">pfsx</a>
D 24	PF-Sym-Y	0.000		<a href="#">pfsy</a>
D 25	PF-Sym	0.000		<a href="#">pfs</a>

Refresh

**Figure 155: Menu VC Ultrasonic profile of velocities**

Additional profile specifications can be calculated from the various path speeds and displayed in this menu for an IGM ultrasonic meter. Refer also to *chapter 5.3.2 UA Ultrasonic volume transmitter*.

### 5.3.12 VD Volume flow

#### VD Average values

Access Line	Designation	Value	Unit	Variable
D 1	Current value	0.000	m3/h	<a href="#">qMom</a>
D 2	Event mean value	0.000	m3/h	<a href="#">qEmiv</a>
D 3	Hourly mean value	0.000	m3/h	<a href="#">qHmiw</a>
D 4	Q > Qt currently	No		<a href="#">QqtQt</a>
D 5	Q > Qt complete hour	No		<a href="#">QqtQth</a>
D 10	Qt transition flow	100.000	m3/h	<a href="#">Qt</a>

Refresh

**Figure 156: Menu VD Volume flow**

This menu shows information about the volume flow of an IGM ultrasonic meter; see *chapter 5.3.2 UA Ultrasonic volume transmitter*.

### 5.3.13 VE Messages

#### VE Messages

Access Line	Designation	Value	Unit	Variable
A *	43 Alarm LED	Uncertain		dzuAS
D	44 Warning LED	Uncertain		dzuWS
I	45 Message 0...15	0000	hex	dzuE01
I	46 Message 16...31	0000	hex	dzuE02
I	47 Message 32...47	0000	hex	dzuE03
I	48 Message 48...63	0000	hex	dzuE04
I	49 Message 64...79	0000	hex	dzuE05
I	50 Message 80...95	0000	hex	dzuE06
I	51 Message 96..111	0000	hex	dzuE07
I	52 Message 112..127	0000	hex	dzuE08
I	53 Message 128..143	0000	hex	dzuE09
I	54 Message 144..159	0000	hex	dzuE10
I	55 Message 160..175	0000	hex	dzuE11
I	56 Message 176..191	0000	hex	dzuE12
I	57 Message 192..207	0000	hex	dzuE13
I	58 System status	0000	hex	sysSt

Refresh

225

Figure 157: Menu VE Messages

This menu shows error messages and status information of an IGM ultrasonic meter; see chapter 5.3.2 UA Ultrasonic volume transmitter.

### 5.3.14 VF Signal acceptance

#### VF Signal acceptance

Access Line	Designation	Value	Unit	Variable
D	1 Arithmetic mean	0.00	%	sgaMom
D	2 Hourly mean	0.00	%	sgaMiw
D	3 Traffic light	red		ampel
I	11 Meas.quality	0	%	pfadvalid1
I	12 Meas.quality	0	%	pfadvalid2
I	13 Meas.quality	0	%	pfadvalid3
I	14 Meas.quality	0	%	pfadvalid4
I	15 Meas.quality	0	%	pfadvalid5
I	16 Meas.quality	0	%	pfadvalid6
I	17 Meas.quality	0	%	pfadvalid7
I	19 Meas.quality	0	%	pfadvalid8
D	30 Smallest value	100.00	%	sgaMin
D	31 Associated path	Uncertain		sgaPfMin
D	32 Point in time	DD-MM-YYYY hh:mm:ss		sgaTiMin

Refresh

Figure 158: Menu VF Signal acceptance

This menu shows the quality in the determination of path speeds of an IGM ultrasonic meter; see *chapter 5.3.2 UA Ultrasonic volume transmitter*.

### 5.3.15 VG Signal-to-noise ratio

#### VG Signal-to-noise ratio

Access Line	Designation	Value	Unit	Variable
D 1	Arithmetic mean	0.00	dB	<a href="#">snrMom</a>
D 2	Hourly mean	0.00	dB	<a href="#">snrMiw</a>
I 11	SNR up	0.00	dB	<a href="#">pfadSNRu1</a>
I 12	SNR up	0.00	dB	<a href="#">pfadSNRu2</a>
I 13	SNR up	0.00	dB	<a href="#">pfadSNRu3</a>
I 14	SNR up	0.00	dB	<a href="#">pfadSNRu4</a>
I 15	SNR up	0.00	dB	<a href="#">pfadSNRu5</a>
I 16	SNR up	0.00	dB	<a href="#">pfadSNRu6</a>
I 17	SNR up	0.00	dB	<a href="#">pfadSNRu7</a>
I 18	SNR up	0.00	dB	<a href="#">pfadSNRu8</a>
I 21	SNR down	0.00	dB	<a href="#">pfadSNRd1</a>
I 22	SNR down	0.00	dB	<a href="#">pfadSNRd2</a>
I 23	SNR down	0.00	dB	<a href="#">pfadSNRd3</a>
I 24	SNR down	0.00	dB	<a href="#">pfadSNRd4</a>
I 25	SNR down	0.00	dB	<a href="#">pfadSNRd5</a>
I 26	SNR down	0.00	dB	<a href="#">pfadSNRd6</a>
I 27	SNR down	0.00	dB	<a href="#">pfadSNRd7</a>
I 28	SNR down	0.00	dB	<a href="#">pfadSNRd8</a>
D 30	Smallest value	1000000.00	dB	<a href="#">snrMin</a>
D 31	Associated path	Uncertain		<a href="#">snrPfMin</a>
D 32	Point in time	DD-MM-YYYY hh:mm:ss		<a href="#">snrTiMin</a>

**Figure 159: Menu VG Signal-to-noise ratio**

This menu shows the signal quality in the run-time determination; the signal-to-noise ratio of the ultrasonic sensors of an IGM ultrasonic meter is specified; see *chapter 5.3.2 UA Ultrasonic volume transmitter*.

### 5.3.16 VH Automatic gain control

#### VH Automatic gain control

Access Line	Designation	Value	Unit	Variable
D 1	Arithmetic mean	0.00		<a href="#">agcMom</a>
D 2	Hourly mean	0.00		<a href="#">agcMiw</a>
I 11	AGC up	0.00		<a href="#">agc_up1</a>
I 12	AGC up	0.00		<a href="#">agc_up2</a>
I 13	AGC up	0.00		<a href="#">agc_up3</a>
I 14	AGC up	0.00		<a href="#">agc_up4</a>
I 15	AGC up	0.00		<a href="#">agc_up5</a>
I 16	AGC up	0.00		<a href="#">agc_up6</a>
I 17	AGC up	0.00		<a href="#">agc_up7</a>
I 18	AGC up	0.00		<a href="#">agc_up8</a>
I 21	AGC down	0.00		<a href="#">agc_dn1</a>
I 22	AGC down	0.00		<a href="#">agc_dn2</a>
I 23	AGC down	0.00		<a href="#">agc_dn3</a>
I 24	AGC down	0.00		<a href="#">agc_dn4</a>
I 25	AGC down	0.00		<a href="#">agc_dn5</a>
I 26	AGC down	0.00		<a href="#">agc_dn6</a>
I 27	AGC down	0.00		<a href="#">agc_dn7</a>
I 28	AGC down	0.00		<a href="#">agc_dn8</a>
D 30	Biggest value	-1000000.00		<a href="#">agcMax</a>
D 31	Associated path	Uncertain		<a href="#">agcPFMax</a>
D 32	Point in time	DD-MM-YYYY hh:mm:ss		<a href="#">agcTMax</a>

Refresh

227

Figure 160: Menu VH Automatic gain control

This menu shows the automatic gain control (AGC) that is applied to the measurement paths up- and downstream; see *chapter 5.3.2 UA Ultrasonic volume transmitter*.

### 5.3.17 VI Gas speed hourly mean value

#### VI Hourly mean velocity of gas

Access Line	Designation	Value	Unit	Variable
D 1	Arithmetic mean	0.000	m/s	<a href="#">velMiw</a>
D 11	Avg. V gas	0.000	m/s	<a href="#">pfadv1m</a>
D 12	Avg. V gas	0.000	m/s	<a href="#">pfadv2m</a>
D 13	Avg. V gas	0.000	m/s	<a href="#">pfadv3m</a>
D 14	Avg. V gas	0.000	m/s	<a href="#">pfadv4m</a>
D 15	Avg. V gas	0.000	m/s	<a href="#">pfadv5m</a>
D 16	Avg. V gas	0.000	m/s	<a href="#">pfadv6m</a>
D 17	Avg. V gas	0.000	m/s	<a href="#">pfadv7m</a>
D 18	Avg. V gas	0.000	m/s	<a href="#">pfadv8m</a>

Refresh

Figure 161: Menu VI Gas speed hourly mean value

This menu shows the hourly mean value of the individual speeds and that of the means value of an IGM ultrasonic meter; see *chapter 5.3.2 UA Ultrasonic volume transmitter*.

### 5.3.18 LO Digital totalizer transmission

#### LO Digital totalizer transmission, ultrasonic flow meter

Access Line	Designation	Value	Unit	Variable
I 1	USZ Vm 1	.000000	m3	<a href="#">Dzu1Zw</a>
I 2	USZ VmD 1	.000000	m3	<a href="#">sDzu1Zw</a>
I 3	USZ Vm 2	.000000	m3	<a href="#">Dzu2Zw</a>
I 4	USZ VmD 2	.000000	m3	<a href="#">sDzu2Zw</a>
I 5	USZ flow	0	m3/h	<a href="#">qDzu</a>
I 6	USZ direction	0		<a href="#">fwDzu</a>
I 7	USZ status	0		<a href="#">stDzu</a>
I 8	Sum direction 1	.000000	m3	<a href="#">qDzu1Zw</a>
I 9	Sum direction 2	.000000	m3	<a href="#">qDzu2Zw</a>
I 10	Total volume	.000000	m3	<a href="#">qDzuZw</a>
I 11	Temperature	-273	°C	<a href="#">tempDzu</a>
I 12	Abs. pressure	0	bar	<a href="#">drkaDzu</a>
I 13	Counter info	0000	hex	<a href="#">zwinfo</a>
B 20	USZ timeout	<input type="text" value="10"/>	s	<a href="#">dzuTimeout</a>
B 21	Eval. of direction	<input type="text" value="immediately"/>		<a href="#">bldDzuDir</a>
B 22	Eval. of status	<input type="text" value="immediately"/>		<a href="#">bldDzuSt</a>
B 23	Counter Vo archive	<input type="text" value="sum counter"/>		<a href="#">dzu2Vo</a>
G *	Unit of flow	<b>m3/h</b>		<a href="#">dzuFdim</a>
G *	Unit of counter	<b>m3</b>		<a href="#">dzuZdim</a>
G *	Unit of temperature	<b>°C</b>		<a href="#">dzuTdim</a>
G *	Unit of pressure	<b>bar</b>		<a href="#">dzuPdim</a>
G *	Unit of velocity	<b>m/s</b>		<a href="#">dzuVdim</a>
D 30	USZ test status	0		<a href="#">zwPruef</a>
D 31	Overflow	.000000	m3	<a href="#">dzuOvfl</a>
D 32	Running USZ timeout	0	s	<a href="#">dzuTimCnt</a>
D 33	Max. cycle quantity	.000000	m3	<a href="#">dzuZykMax</a>
D 34	USZ cycle quantity		m3	<a href="#">dzuZykMng</a>
D 35	USZ direction	Direction 1		<a href="#">dzuDirec</a>
D 36	Unit AGC			<a href="#">aqcEinh</a>

**Figure 162: Menu Digital totalizer transmission**

Display of diagnostic information associated with a connected US 9000 computer with main totalizer function.

## 5.4 Connection of USZs via Instance F

There has been a desire for some time to standardize the connection of ultrasonic meters to further electronic evaluation units. In particular, the desire arose to transmit "all" data determined by an ultrasonic meter, i.e. measurements and status information or diagnostic data, in the same manner. Recently, the connection via Instance F crystallized as a standard.

### 5.4.1 Explanation of the term Instance F

Ultrasonic meters normally do not have dedicated DSfG bus access. Therefore, Instance F was implemented externally via a DSfG-compatible flow rate computer. The data required for this is transmitted via Modbus between ultrasonic meters and flow rate computers. This Modbus protocol is frequently already called Instance F, although it is only prepared for the data required for the DSfG Instance F. In the **ERZ2000-NG**, the appropriate settings are found in menu **VK Modbus master USM**. The corresponding register plots are provided in menu **VJ Register expressions**.

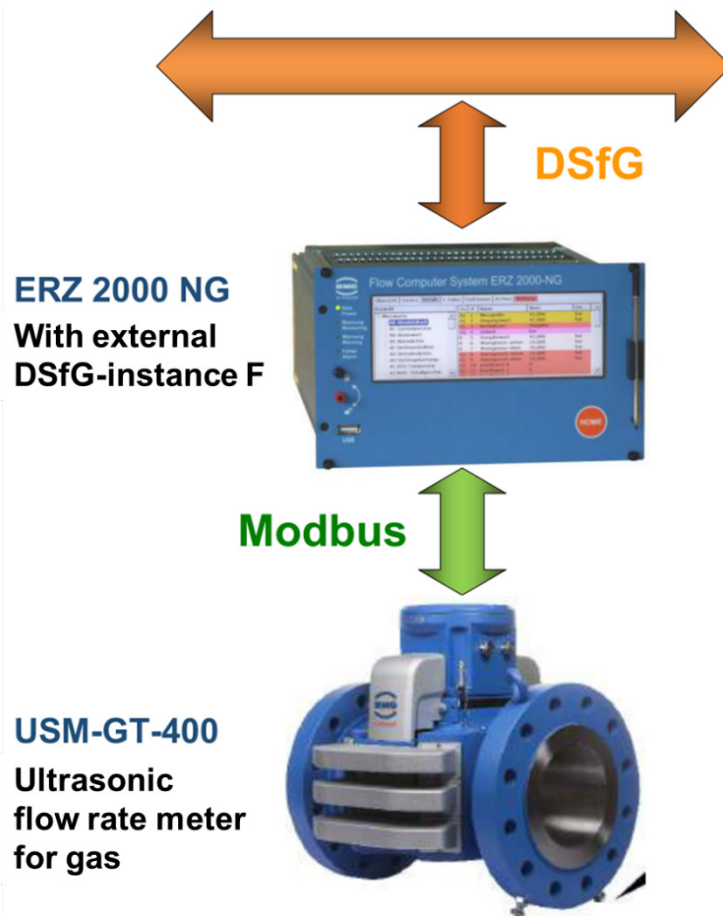


Figure 163: Data exchange between ERZ2000-NG and USM GT400

## 5.4.2 Modbus communication with the USM GT400

The Modbus communication between ERZ2000-NG and ultrasonic meters is described as generally as possible, wherein the USM GT400 was chosen as a concrete example (Figure 1). The Modbus registers of Instance F are listed in column BA in the USM GT400.

## 5.4.3 Electrical connection

Figure 164: Connection of the Modbus interface of the USM to COM 6 shows the rear wall of the ERZ2000-NG. The USM GT400 is connected to serial interface COM6.

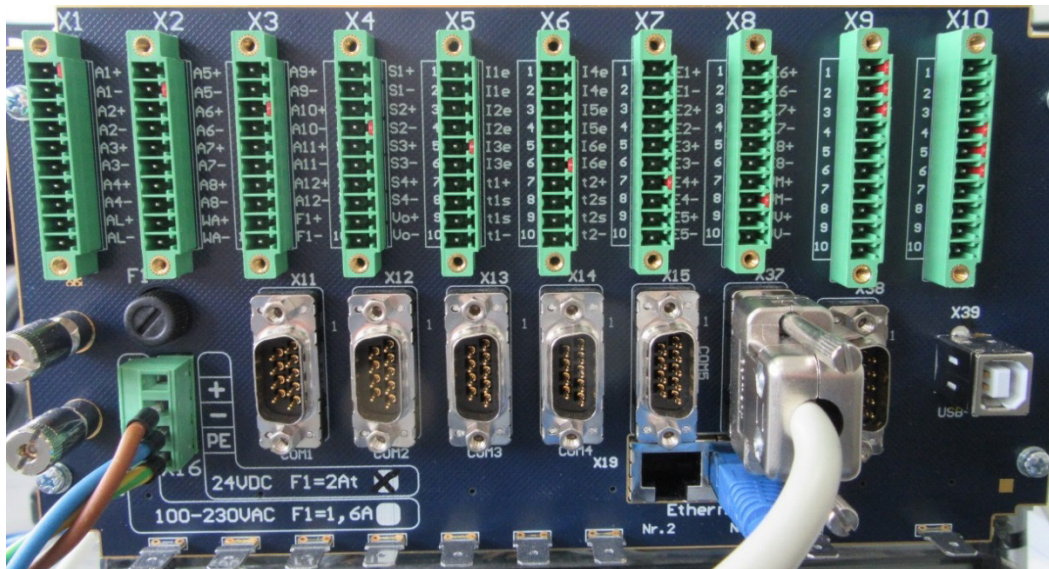


Figure 164: Connection of the Modbus interface of the USM to COM 6

## 5.4.4 USM GT400 connection area

There are three serial interfaces available for Modbus communication on the **USM GT400** ultrasonic meter (and USZ 08). The **RS 485-2** with terminal 21 (**GND**), terminal 22 (**Data +**) and terminal 23 (**Data -**) is provided for the Instance F Modbus communication; based on the parameterizable byte sequence, it is suitable for the manufacturer-independent Instance F protocol. The other interfaces can be used without any further settings. The **RS 485-0** with terminal 15 (**GND**), terminal 16 (**Data +**) and terminal 17 (**Data -**) is reserved for the operating and service software RMGView<sup>USM</sup>. The **RS 485-1** with terminal 18 (**GND**), terminal 19 (**Data +**) and terminal 20 (**Data -**) should (preferably) be used for the RMG standard of the digital totalizer status transmission "DZU".



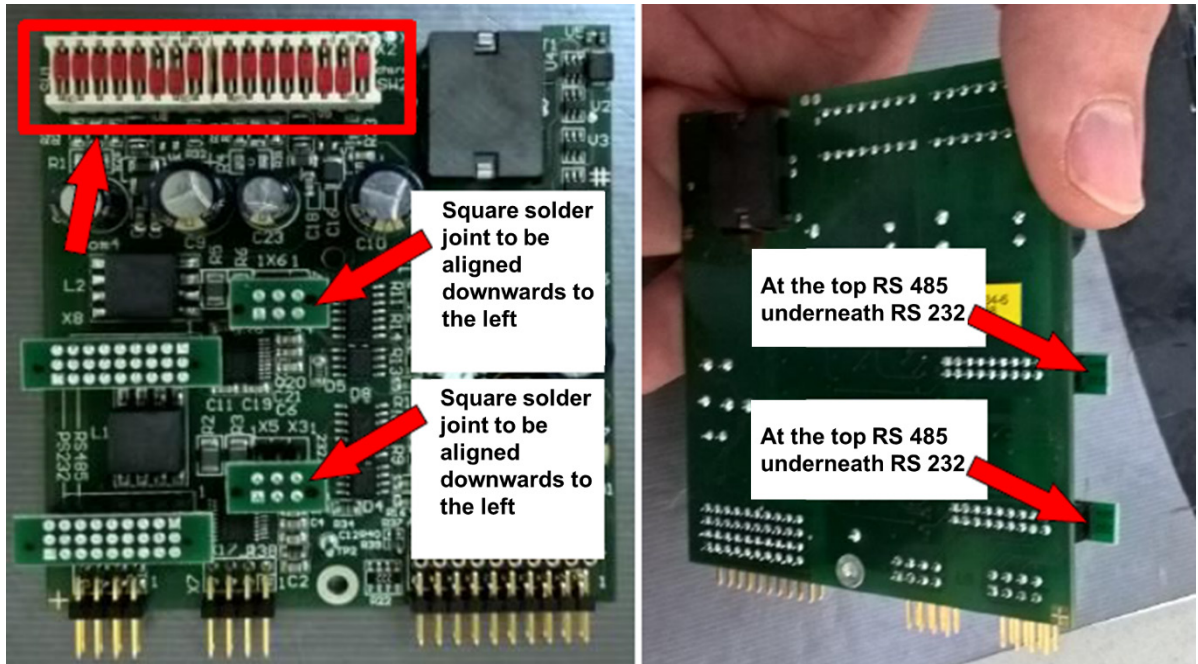


**Figure 165: Connection of the RS 485-2 (22 +, 23 -) on the USM GT400**

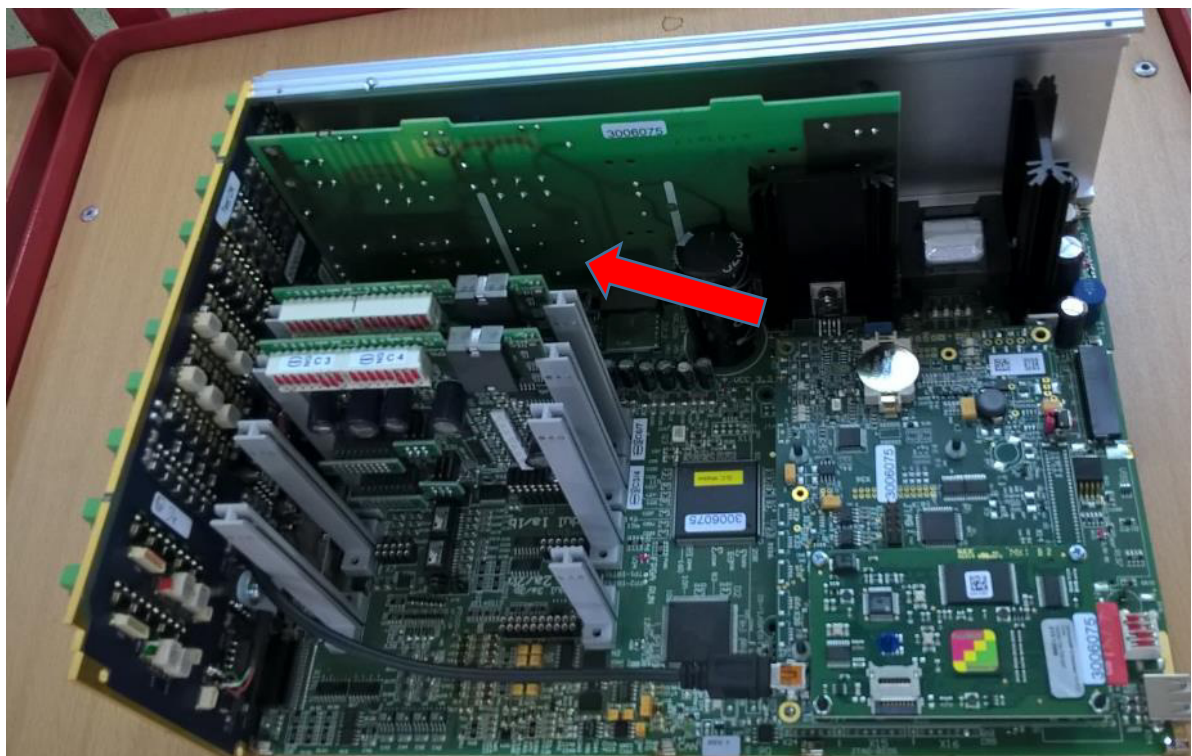
#### 5.4.5 Configuration for COM6 and COM7

The optional COM 6 interface is required by the ERZ2000-NG for communication with ultrasonic meters via Instance F. The DIL switches and jumpers for the RS 485 on the optional board required for this purpose must be adjusted as shown in *Figure 166: Option board configuration for use as COM6 and 7*. Switch 2 and switch 3 (when counted from the left) of the DIL switches on the board must be set to ON. The positioning of the jumpers is indicated in the figure.

Then, the option board must be positioned in the COM6 and 7 slot, which is the first from the right when viewing the display (*Figure 167: Slot of the option board for COM6 and 7*).

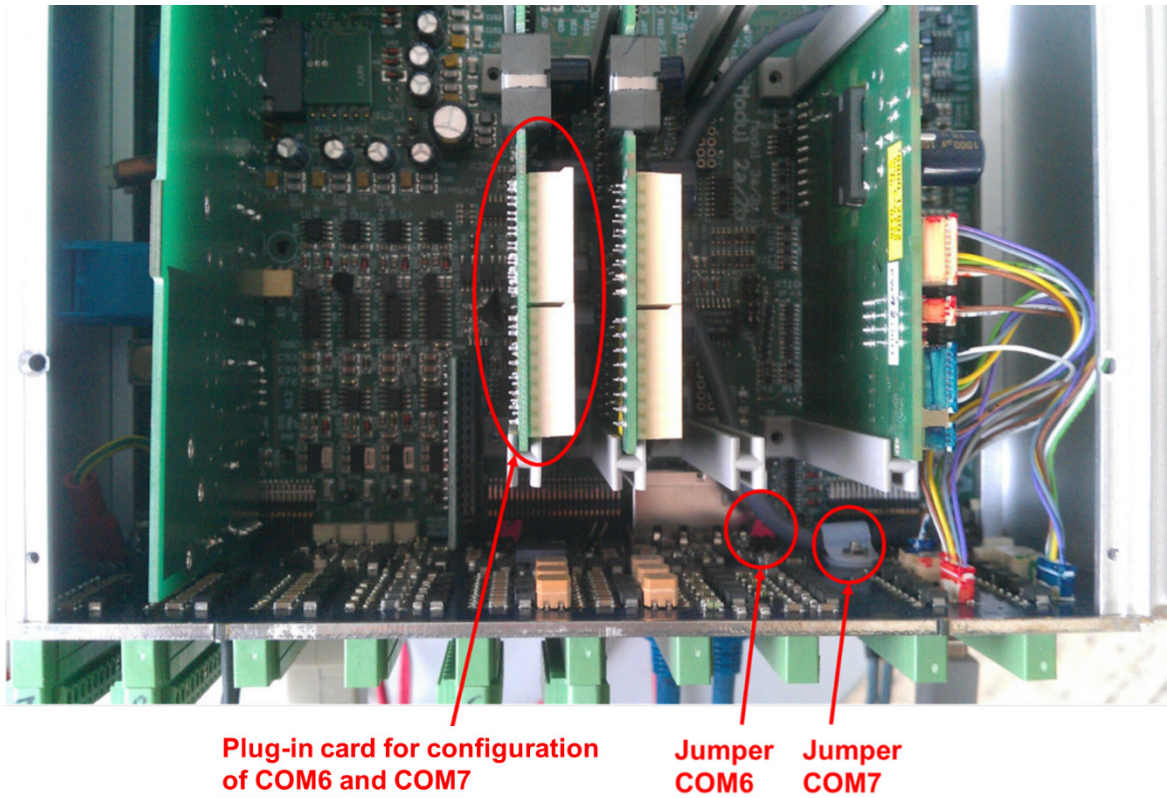


**Figure 166: Option board configuration for use as COM6 and 7**



**Figure 167: Slot of the option board for COM6 and 7**

Figure 167: Slot of the option board for COM6 and 7 shows the rear side of the ERZ2000-NG on the left. Figure 168: Jumpers for COM6 and COM7 on the rear wall shows the rear side of the ERZ2000-NG at the bottom.



**Figure 168: Jumpers for COM6 and COM7 on the rear wall**

The jumpers for COM6 and COM7 must be set according to the equipment of interface module C34 (see Figure 169: Interface module C34) so that the interfaces can be used as RS485.

In the two following illustrations you can see that the COM 6 and COM 7 interfaces are only set as RS485 interfaces if the jumpers are set or soldered to the D-sub connector.

Rückwand

ERZ2000NG/DI-Top

Schnittstellenmodul\_C34

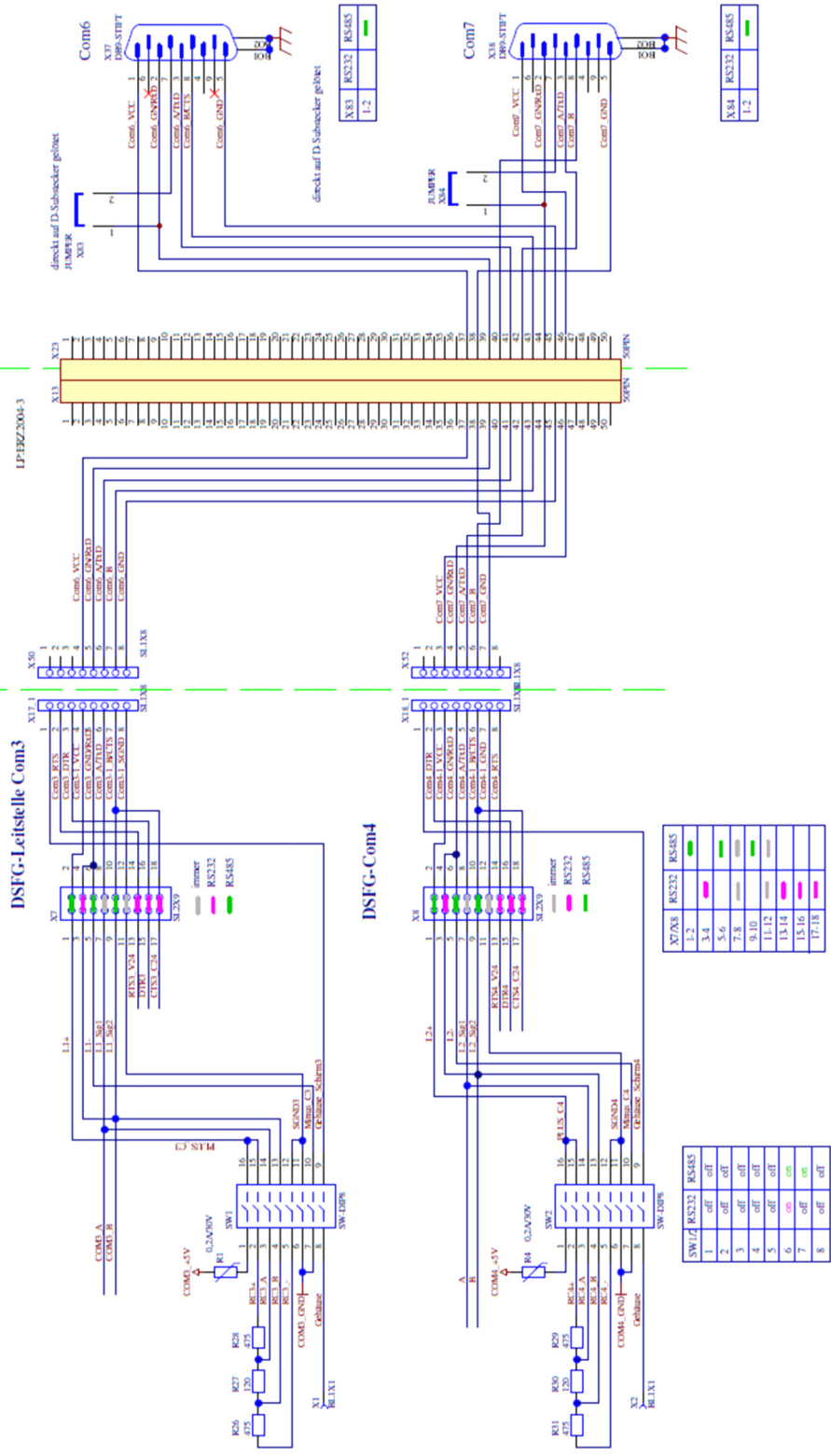


Figure 169: Interface module C34

The magnification of the right (upper) image cutout shows how to set the jumpers.

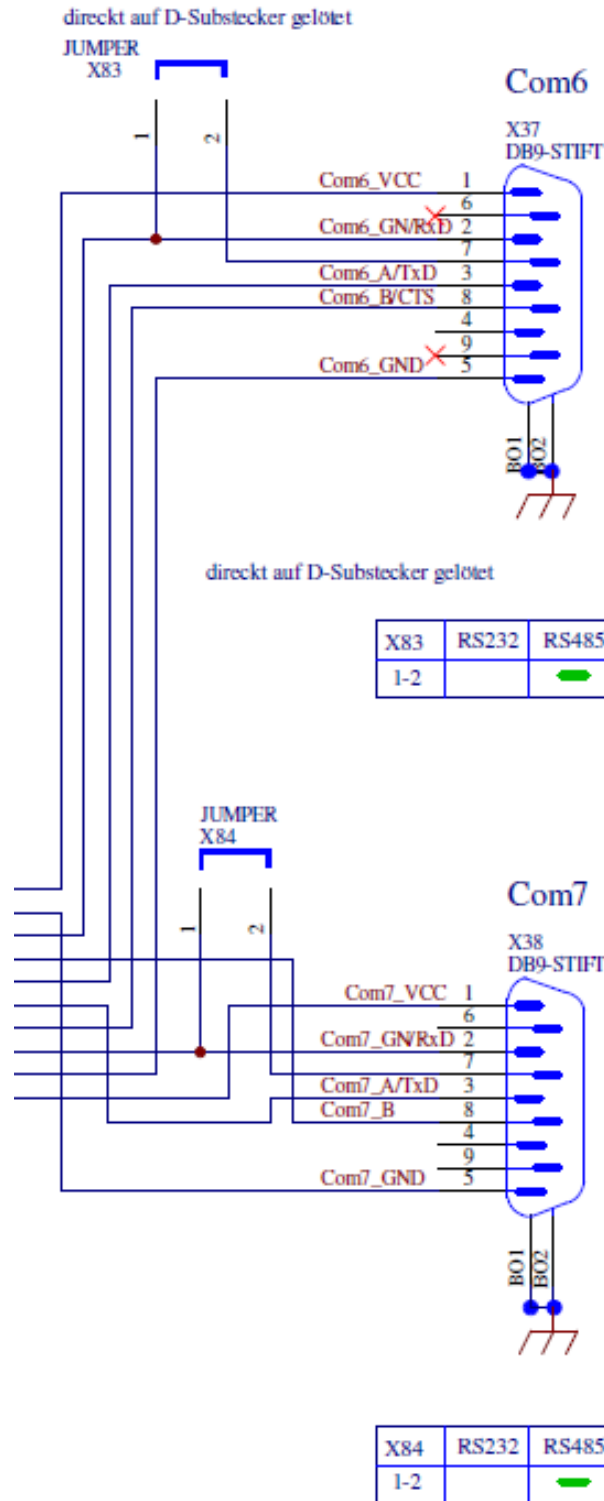


Figure 170: Jumper COM6/7 on the rear wall

### 5.4.6 Volume transmitter operating mode

If "DSfG: F instance COM6/7" under this button is activated under this in menu **GB Flow rate parameters**, the additional necessary settings are recommended in this menu (bright yellow-green background):

- **GB16 Volume transmitter mode** ▶ "DZU"
- **GB51 Device type** ▶ "USM-GT400"
- **GB53 Volume transmitter type** ▶ "USZ"

### GB Flow rate parameters

Access Line	Designation	Value	Unit	Variable
A *	1	Qm max	1000.000	m3/h <a href="#">quMax</a>
A *	2	Qm min	0.000	m3/h <a href="#">QuMin</a>
E *	3	High pressure ext.	No	<a href="#">HdErw</a>
...				
E *	15	LF measurable	Yes	<a href="#">Nf2Qb</a>
E *	16	Vol.transd. mode	USZ	<a href="#">volGebMod</a>
E *	17	Start-up pulses	500	pulses <a href="#">anlaufPulse</a>
...				
E *	51	Device type	USM-GT400	<a href="#">zwkGerTp</a>
E *	52	Serial number	0	<a href="#">zwkSerNr</a>
E *	53	Meter type	USM	<a href="#">zwkPrinzip</a>
E *	54	Meter size	G650	<a href="#">zGroesse</a>
Q	55	Freq.turbinesim.	0	Hz <a href="#">hfSim</a>
<input type="button" value="Enter"/> <input type="button" value="Cancel"/> <input type="button" value="DSfG: F-Instanz COM6/7"/> <input type="button" value="Refresh"/>				

**Figure 171: DZU selection in volume transmitter mode GB16**

Then, the recommendation must be "entered" and adopted with "continue".

### 5.4.7 Protocol type in menu VJ Register plots

After selection of volume transmitter "DZU", the protocol type "DSfG: F Instance ("1") must be defined by pushing a button in menu **VJ Register expressions**. Then the appropriate registers for Modbus communication are recommended.

### VJ Register expressions

Access Line	Designation	Value	Unit	Variable
E *	1	Volume flow	F32768	m3/h <a href="#">exp3q</a>
B	2	Velocity of gas	F32770	m/s <a href="#">exp3v</a>
B	3	Speed of sound	F32772	m/s <a href="#">exp3vos</a>
E *	4	Gas vol. total 1	U32774	<a href="#">exp3vbgR1</a>
E *	5	Gas vol. total 2	U32776	<a href="#">exp3vbgR2</a>
...				
B	74	Signal acceptance 8	F33012	% <a href="#">exp3sigAk8</a>
B	75	Signal-to-noise AB8	F33014	dB <a href="#">exp3SNRAB8</a>
B	76	Signal-to-noise BA8	F33016	dB <a href="#">exp3SNRBA8</a>
B	77	Automatic gain AB 8	F33018	dB <a href="#">exp3AGCAB8</a>
B	78	Automatic gain BA 8	F33020	dB <a href="#">exp3AGCBA8</a>
B	98	used button	DSfG: F-Instanz	<a href="#">exp3btn</a>
D	99	No. communications	0	<a href="#">mb3Tgs</a>

Enter

Cancel

DSfG: F-Instanz

Refresh

RMG: USM-GT400/USZ-08

FL500

FL600

FL600XT

AltoSonic V12

LEFM 380Ci

**Figure 172: DSfG selection: F Instance in VJ98**

Then, the recommendation must be "entered" ("2"), i.e. adopted. Many other parameters in addition to the volume flow can be transmitted in the complete menu.

The connection and selection of all other listed ultrasonic meters are also permissible for official custody-transfer applications.

Then, the recommendation which was entered is shown in coordinate **VJ98 Used button**.

238

Note	
<p><b>Caution:</b></p> <p>Even if, for example, the "swirl" information is transmitted in the same field with the same register, the "swirl" value is defined depending on the device and can deviate significantly between different measuring devices. The same applies for all device-specific parameters.</p>	

### 5.4.8 COM6 interface configuration

The COM6 serial interface must be operated with parameters 38400 Baud, 8 bits, parity None and 1 stop bit, as well as the operating mode of universal Modbus master for communication with ultrasonic meters via Instance F. This is located in **IB Serial interfaces** in coordinates **IB31 to IB33** (Figure 173: COM6 interface configuration).

#### IB Serial interfaces

Access	Line	Designation	Value	Unit Variable
...				
B	31	Baud rate COM6	38400 ▾	<a href="#">baudC6</a>
B	32	B/P/S COM6	8N1 ▾	<a href="#">bpsC6</a>
B	33	COM6 operating mode	Univ.Modbus.Master ▾	<a href="#">modeC6</a>

**Figure 173: COM6 interface configuration**

Note	
<p>Then, COM6 is no longer available for communication with gas chromatographs. Therefore, the Modbus master communication for GC1 and GC2 must be assigned or deactivated in coordinates IL50 and IL51 of serial interface COM7 (Figure 174: Modbus serial C7 operating mode) (Figure 175: Operating mode off), provided that no Modbus IP should be used.</p>	



**IL Modbus Master GC1**

Access Line	Designation	Value	Unit	Variable
E *	50	Operating mode	Modbus-serial C7	mb1_ifac
E *	51	IP-Address	10.20.13.71	mb1_ipAdr
E *	52	Modbus address	1	mb1_Adr
E *	53	ModbusIP timeout	2000	ms mb1timo

239

**Figure 174: Modbus serial C7 operating mode**

**IM Modbus Master GC2**

Access Line	Designation	Value	Unit	Variable
E *	50	Operating mode	OFF	mb2_ifac
E *	51	IP-Address	10.20.13.71	mb2_ipAdr
E *	52	Modbus address	1	mb2_Adr
E *	53	ModbusIP timeout	2000	ms mb2timo

**Figure 175: Operating mode off**

**5.4.9 Configuration VK Modbus according to Instance F**

For communication via DSfG Instance F, **VK Modbus master USM** must be parameterized in accordance with DSFG Instance F specifications, as shown in *Figure 176: Configuration of Modbus master USM according to Instance F.*

**VK Modbus Master USM**

Access Line	Designation	Value	Unit	Variable
D	32	Communication	waiting	mb3_ok
D	35	Exception code	0	mb3ExcCod
D	36	Exception counter	0	mb3ExcCnt
E *	50	Operating mode	OFF	mb3_ifac
E *	52	Modbus address	1	mb3_Adr
E *	53	Slave accepts gaps	Yes	mb3_loecher
E *	54	Maximum gap size	20	mb3_loch
E *	55	Byteorder 16Bit Int	21	mb3_bo_u
E *	56	Byteorder 32Bit Int	4321	mb3_bo_U
E *	57	Byteorder float	4321	mb3_bo_F
E *	58	Byteorder double	21436587	mb3_bo_D
E *	59	Byteorder 64Bit Int	12345678	mb3_bo_V
E *	60	Register	16 bit oriented	mb3_sick
E *	61	Read function code	3	mb3_fc
E *	62	Modbus dialect	Modbus-RTU	mb3_mbtvp
E *	63	Register offset	-1	mb3_regOffs
B	98	used button	DSfG: F-Instanz	exp3btn_2

Enter Cancel DSfG: F-Instanz Refresh

**Figure 176: Configuration of Modbus master USM according to Instance F**

The Modbus address in **VK52** must match the address of the ultrasonic meter. For the USM GT400, it is located in **J-31**, provided that the RS 485-2 is used for communication via Instance F (*chapter 5.4.11 Configuration USM GT400*). The selection values in **VK58** and in **VK59** have no influence in this case because these data types are not included in the Instance F protocol.

#### 5.4.10 Configuration menu VK for USM GT400 RS 485-1

If the interface RS 485-1 for data communication is selected on the USM GT400 with the ERZ2000-NG via Instance F protocol, different settings of the Modbus master USM in column VK are required due to the non-parameterizable byte sequence for the data types long and float.

The button "RMG: USM.GT400/USZ-08" (see: *Figure 172: DSfG selection: F Instance in VJ98*) can be used for this purpose, wherein the byte sequence **VK56** and **VK57** is adjusted and the register **VK63** is set to 0. The same setting can also be made in the USM GT400 in **J-21**.

Alternatively, a manual adjustment can take place in menu **VK Modbus master USM**. Then, **2143** must be entered in **VK56** and **VK57** (*Figure 177: Configuration of the Modbus master USM for the RS 485-1 of the USM GT400*). The register offset in **VK63** can remain -1. In this case, the value 1 must be entered in the USM GT400 in **J-21**. It is also possible to set both values to 0, as is the case with the button selection. The Modbus address in **VK52** must match the address of the ultrasonic gas meter.

**VK Modbus Master USM**

Access	Line	Designation	Value	Unit	Variable
D	32	Communication	waiting		<a href="#">mb3_ok</a>
D	35	Exception code	0		<a href="#">mb3ExcCod</a>
D	36	Exception counter	0		<a href="#">mb3ExcCnt</a>
E *	50	Operating mode	OFF		<a href="#">mb3_ifac</a>
E *	52	Modbus address	1		<a href="#">mb3_Adr</a>
E *	53	Slave accepts gaps	Yes		<a href="#">mb3_loecher</a>
E *	54	Maximum gap size	20		<a href="#">mb3_loch</a>
E *	55	Byteorder 16Bit Int	21		<a href="#">mb3_bo_u</a>
E *	56	Byteorder 32Bit Int	4321		<a href="#">mb3_bo_U</a>
E *	57	Byteorder float	4321		<a href="#">mb3_bo_F</a>
E *	58	Byteorder double	21436587		<a href="#">mb3_bo_D</a>
E *	59	Byteorder 64Bit Int	12345678		<a href="#">mb3_bo_V</a>
E *	60	Register	16 bit oriented		<a href="#">mb3_sick</a>
E *	61	Read function code	3		<a href="#">mb3_fc</a>
E *	62	Modbus dialect	Modbus-RTU		<a href="#">mb3_mbtyp</a>
E *	63	Register offset	-1		<a href="#">mb3_reqOffs</a>
B	98	used button	DSfG: F-Instanz		<a href="#">exp3btn_2</a>

Enter	Cancel	DSfG: F-Instanz	Refresh
RMG: USM-GT400/USZ-08			
FL500			
FL600			
FL600XT			
AltoSonic V12			
LEFM 380Ci			

**Figure 177: Configuration of the Modbus master USM for the RS 485-1 of the USM GT400**

Then, the recommendation which was entered is shown in coordinate **VK98 used button**.

**5.4.11 Configuration USM GT400 for Instance F**

**Serial interface RS 485-2 (opt. Ser2)**

If the ERZ2000-NG is configured in accordance with DSfG Instance F specifications, as described in *chapter 5.4.9 Configuration VK Modbus according to Instance F*, the USM GT400 must be connected to the RS 485-2 interface. This is located in coordinates **J-25 to J-37** under the designation "Opt. Ser2" and must be parameterized in the same manner as in *Figure 178: Parameterization of RS 485-2 for Modbus in accordance with Instance F*. The Modbus address in **J-31** can be freely assigned and must be entered identically in the ERZ2000-NG in **VK52**.

J-25	Opt. Ser2 Modus	Modbus			2112
J-26	Opt. Ser2 Baudrate	38400	baud		2113
J-27	Opt. Ser2 Bits	8			2114
J-28	Opt. Ser2 Parität	KEINE			2115
J-29	Modbus-2 Protokoll	RTU			2178
J-30	Modbus-2 HW-Mode	RS485			2179
J-31	Modbus-2 Adresse		1		2180
J-32	Modbus-2 Reg. Offset		1		2181
J-33	Modbus-2 Gap time		45		2182
J-34	Long Byte order	SWAPPED			2251
J-35	Float Byte order	SWAPPED			2252
J-36	Double Byte order	NORMAL			2253
J-37	DZU-2 Adresse		3		2285

**Figure 178: Parameterization of RS 485-2 for Modbus in accordance with Instance F**

### Serial interface RS 485-1 (serial-1)

The RS 485-1 serial interface also enables data communication via Modbus in accordance with Instance F, but long and float are defined for the data types, unlike the Modicon specifications for byte sequence 2143. This must be considered for the configuration for the Modbus master USM in menu **VK Modbus master USM** of the ERZ2000-NG, where the byte sequence 2143 must also be selected in **VK56** and **VK57**. If, for this purpose, the button "RMG: USM.GT400/USZ-08" is used in the ERZ2000-NG (see *chapter 5.4.10 Configuration menu VK for USM GT400 RS 485-1*), the register offset the USM GT400 in **J-21** must be set to 0. *Figure 179: Parameterization of RS 485-1 for Modbus in accordance with Instance F* shows a register offset of 1, which must then be selected if the standard value -1 is the setting in the ERZ2000-NG in **VK63**. In addition, the freely programmable Modbus address in **J-20** of the USM GT400 must also be used in the ERZ2000-NG in coordinate **VK52**.

J-14	Seriell-1 Modus	Modbus			2107
J-15	Seriell-1 Baudrate	38400	baud		2108
J-16	Seriell-1 Bits	8			2109
J-17	Seriell-1 Parität	KEINE			2110
J-18	Modbus-1 Protokoll	RTU			2286
J-19	Nicht verfügbar	RS485			2287
J-20	Modbus-1 Adresse		1		2288
J-21	Modbus-1 Reg. Offset		1		2289
J-22	Modbus-1 Gap time		45		2290
J-23	DZU-1 Adresse		2		2284

**Figure 179: Parameterization of RS 485-1 for Modbus in accordance with Instance F**

## 5.4.12 Modbus register for Instance F

### Modbus register list

The following table actually represents a DSfG data element list (DEL). It is manufacturer-independent and describes the data storage and/or data elements of a type of ultrasonic meter. The data elements were numbered starting from 8000h in a suitable manner for the Modbus. The resulting Modbus addresses can be viewed in the register column. The Modbus data type is specified in the "Type" column.

243

Modbus Reg.	Type	Name	Description
		General part	Refer to the general part of the data element list
		Gas meter	
		Ultrasonic type	
		Path-independent values (current values)	
32768	float	Volume flow (pos. FR1, neg. FR2)	[m <sup>3</sup> /h]
32770	float	Gas speed (pos. FR1, neg. FR2)	[m/s]
32772	float	Speed of sound	[m/s]
32774	long	Total gas volume FR1 (V_tot_r1=Vb_r1+Vb_int_r1)	[m <sup>3</sup> ]
32776	long	Total gas volume FR2 (V_tot_r2=Vb_r2+Vb_int_r2)	[m <sup>3</sup> ]
32778	long	Gas volume undisturbed FR1 (Vb_r1)	[m <sup>3</sup> ]
32780	long	Gas volume undisturbed FR2 (Vb_r2)	[m <sup>3</sup> ]
32782	long	Gas volume disturbed FR1 (Vb_stör_r1)	[m <sup>3</sup> ]
32784	long	Gas volume disturbed FR2 (Vb_stör_r2)	[m <sup>3</sup> ]
32786	long	Significance (all meters)	Power of ten of the lowest meter position (permissible values: -2, -1, 0, 1, 2, 3)
32788	long	Flow greater than Qt	0=no, not equal to 0 = ja
32790	long	Signal acceptance	Signal lamp: 0..33 = red, 34..66 = yellow, 67..100 = green [1]
32792	long	Meter disturbed	0=no, not equal to 0 = ja
32794	long	Number of paths	
32796	float	Speed of sound deviation of path 1	[%] $c_{1\_dev} = (c_{1-c})/c*100$
32798	float	Speed of sound deviation of path 2	[%] $c_{2\_dev} = (c_{2-c})/c*100$
32800	float	Speed of sound deviation of path 3	[%] $c_{3\_dev} = (c_{3-c})/c*100$
32802	float	Speed of sound deviation of path 4	[%] $c_{4\_dev} = (c_{4-c})/c*100$
32804	float	Speed of sound deviation of path 5	[%] $c_{5\_dev} = (c_{5-c})/c*100$
32806	float	Speed of sound deviation of path 6	[%] $c_{6\_dev} = (c_{6-c})/c*100$
32808	float	Speed of sound deviation of path 7	[%] $c_{7\_dev} = (c_{7-c})/c*100$
32810	float	Speed of sound deviation of path 8	[%] $c_{8\_dev} = (c_{8-c})/c*100$
32812		Range reserved for additional paths and for digital signature	
32814			

		<b>Path-dependent values of path 1 (current values)</b>	
32896	float	Path speed	[m/s]
32898	float	Speed of sound	[m/s]
32900	float	Signal acceptance	[%]
32902	float	Signal-to-noise ratio AB	[dB]
32904	float	Signal-to-noise ratio BA	[dB]
32906	float	Automatic amplification AB	[dB]
32908	float	Automatic amplification BA	[dB]
32910	float	reserved, always = 0	
		<b>Path-dependent values of path 2 (current values)</b>	
32912	float	Path speed	[m/s]
32914	float	Speed of sound	[m/s]
32916	float	Signal acceptance	[%]
32918	float	Signal-to-noise ratio AB	[dB]
32920	float	Signal-to-noise ratio BA	[dB]
32922	float	Automatic amplification AB	[dB]
32924	float	Automatic amplification BA	[dB]
32926	float	reserved, always = 0	
		<b>Path-dependent values of path 3 (current values)</b>	
32928	float	Path speed	[m/s]
32930	float	Speed of sound	[m/s]
32932	float	Signal acceptance	[%]
32934	float	Signal-to-noise ratio AB	[dB]
32936	float	Signal-to-noise ratio BA	[dB]
32938	float	Automatic amplification AB	[dB]
32940	float	Automatic amplification BA	[dB]
32942	float	reserved, always = 0	
		<b>Path-dependent values of path 4 (current values)</b>	
32944	float	Path speed	[m/s]
32946	float	Speed of sound	[m/s]
32948	float	Signal acceptance	[%]
32950	float	Signal-to-noise ratio AB	[dB]
32952	float	Signal-to-noise ratio BA	[dB]
32954	float	Automatic amplification AB	[dB]
32956	float	Automatic amplification BA	[dB]
32958	float	reserved, always = 0	
		<b>Path-dependent values of path 5 (current values)</b>	
32960	float	Path speed	[m/s]
32962	float	Speed of sound	[m/s]

32964	float	Signal acceptance	[%]
32966	float	Signal-to-noise ratio AB	[dB]
32968	float	Signal-to-noise ratio BA	[dB]
32970	float	Automatic amplification AB	[dB]
32972	float	Automatic amplification BA	[dB]
32974	float	reserved, always = 0	
		<b>Path-dependent values of path 6 (current values)</b>	
32976	float	Path speed	[m/s]
32978	float	Velocity of sound	[m/s]
32980	float	Signal acceptance	[%]
32982	float	Signal-to-noise ratio AB	[dB]
32984	float	Signal-to-noise ratio BA	[dB]
32986	float	Automatic amplification AB	[dB]
32988	float	Automatic amplification BA	[dB]
32990	float	reserved, always = 0	
		<b>Path-dependent values of path 7 (current values)</b>	
32992	float	Path speed	[m/s]
32994	float	Speed of sound	[m/s]
32996	float	Signal acceptance	[%]
32998	float	Signal-to-noise ratio AB	[dB]
33000	float	Signal-to-noise ratio BA	[dB]
33002	float	Automatic amplification AB	[dB]
33004	float	Automatic amplification BA	[dB]
33006	float	reserved, always = 0	
		<b>Path-dependent values of path 8 (current values)</b>	
33008	float	Path speed	[m/s]
33010	float	Speed of sound	[m/s]
33012	float	Signal acceptance	[%]
33014	float	Signal-to-noise ratio AB	[dB]
33016	float	Signal-to-noise ratio BA	[dB]
33018	float	Automatic amplification AB	[dB]
33020	float	Automatic amplification BA	[dB]
33022	float	reserved, always = 0	
33024		reserved for additional paths	
33278			

**Table 6: Modbus register list in accordance with Instance F**

### Display of Instance F measurement values and status informations

The Modbus register list is implemented in both the ERZ2000-NG in menu **VJ Register expressions** and in the USM GT400 in menu BA (*Figure 180: Menu BA Instance F in the USM GT400*).

### Instance F measurements and register addresses in the USM GT400

Koordinate	Name	Wert	Einheit	Modbusadresse
BA-1	DSFG Fehler		0000	9086
BA-2	Volumenstrom Qb		53,18 m3/h	32768
BA-3	Gasgeschwindigkeit		3,0521 m/s	32770
BA-4	Schallgeschw.		345,716 m/s	32772
BA-5	Gasvol. gesamt FR1		000000154 x 1	32774
BA-6	Gasvol. gesamt FR2		000000000 x 1	32776
BA-7	Gasvol. unges. FR1		000000154 x 1	32778
BA-8	Gasvol. unges. FR2		000000000 x 1	32780
BA-9	Gasvol. gest. FR1		000000000 x 1	32782
BA-10	Gasvol. gest. FR2		000000000 x 1	32784
BA-11	Wertigkeit		0	32786
BA-12	Durchfluss > Qt		0	32788
BA-13	Signalakzeptanz		100 %	32790
BA-14	Zähler gestört		0	32792
BA-15	Anzahl Pfade		6	32794
BA-16	Abw. Schallgesch. P1		0,03 %	32796
BA-17	Abw. Schallgesch. P2		-0,06 %	32798
BA-18	Abw. Schallgesch. P3		0,03 %	32800
BA-19	Abw. Schallgesch. P4		0,01 %	32802
BA-20	Abw. Schallgesch. P5		-0,05 %	32804
BA-21	Abw. Schallgesch. P6		0,04 %	32806
BA-22	Abw. Schallgesch. P7		0,00 %	32808
BA-23	Abw. Schallgesch. P8		0,00 %	32810
BA-24	Pfadgeschw. vK1		2,350 m/s	32896

**Figure 180: Menu BA Instance F in the USM GT400**

The Modbus registers in accordance with Instance F are listed in **BA-2** to **BA-79** in the USM GT400.



**Instance F measurements and register addresses in the ERZ2000-NG**

The corresponding measurements and status information are displayed in the ERZ2000-NG with closed calibration switch; the Modbus addresses are displayed with closed calibration switch (*Figure 181: Modbus register list in the ERZ2000-NG with closed (left) and opened (right) calibration switch*).

For detailed information, including hourly mean values and deviations of individual values from the mean value, refer to the superordinate **Instance F menu V**, with subdirectories **VA** to **VI** categorized according to measurement headings (*Figure 182: Subdirectories of Instance F menu V in the ERZ2000-NG*).

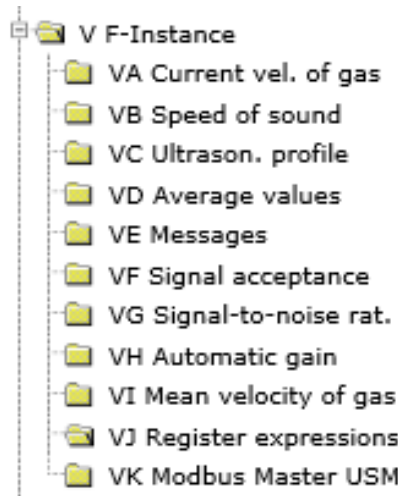
**VJ Register expressions**

Access Line	Designation	Value	Unit	Variable
E * 1	Volume flow	0.00	m3/h	exp3g
B 2	Velocity of gas	0.000	m/s	exp3v
B 3	Speed of sound	0.000	m/s	exp3vos
E * 4	Gas vol. total 1	0.000		exp3vbgR1
E * 5	Gas vol. total 2	0.000		exp3vbgR2
E * 6	Gas vol. undist.1	0.000		exp3vbr1
E * 7	Gas vol. undist.2	0.000		exp3vbr2
E * 8	Gas vol. disturbed1	0.000		exp3svbr1
E * 9	Gas vol. disturbed2	0.000		exp3svbr2
E * 10	Valence	0		exp3factor
B 11	Flow rate > Qt	0		exp3QgtQt
B 12	Signal acceptance	0.00	%	exp3SsigAkz
E * 13	Gas meter disturbed	0		exp3ZAlarm
B 14	Number of paths	0		exp3NrPath
B 15	Deviation of SoS 1	0.00	%	exp3abwVos1
B 16	Deviation of SoS 2	0.00	%	exp3abwVos2
B 17	Deviation of SoS 3	0.00	%	exp3abwVos3
B 18	Deviation of SoS 4	0.00	%	exp3abwVos4
B 19	Deviation of SoS 5	0.00	%	exp3abwVos5
B 20	Deviation of SoS 6	0.00	%	exp3abwVos6
B 21	Deviation of SoS 7	0.00	%	exp3abwVos7
B 22	Deviation of SoS 8	0.00	%	exp3abwVos8
B 23	Path velocity 1	0.000	m/s	exp3v1
B 24	Speed of sound 1	0.000	m/s	exp3vos1
B 25	Signal acceptance 1	0.00	%	exp3siqAk1
B 26	Signal-to-noise AB1	0.00	dB	exp3SNRAB1
B 27	Signal-to-noise BA1	0.00	dB	exp3SNRBA1
B 28	Automatic gain AB 1	0.00	dB	exp3AGCAB1
B 29	Automatic gain BA 1	0.00	dB	exp3AGCBA1
B 30	Path velocity 2	0.000	m/s	exp3v2
B 31	Speed of sound 2	0.000	m/s	exp3vos2
B 32	Signal acceptance 2	0.00	%	exp3siqAk2
B 33	Signal-to-noise AB2	0.00	dB	exp3SNRAB2

**VJ Register expressions**

Access Line	Designation	Value	Unit	Variable
E * 1	Volume flow	F6230	m3/h	exp3g
B 2	Velocity of gas	F6222	m/s	exp3v
B 3	Speed of sound	F6228	m/s	exp3vos
E * 4	Gas vol. total 1	D3016		exp3vbgR1
E * 5	Gas vol. total 2	D3020		exp3vbgR2
E * 6	Gas vol. undist.1	D3000		exp3vbr1
E * 7	Gas vol. undist.2	D3004		exp3vbr2
E * 8	Gas vol. disturbed1	D3008		exp3svbr1
E * 9	Gas vol. disturbed2	D3012		exp3svbr2
E * 10	Valence	0		exp3factor
B 11	Flow rate > Qt	0		exp3QgtQt
B 12	Signal acceptance	u6268	%	exp3SsigAkz
E * 13	Gas meter disturbed	(u4000==1)?1:0		exp3ZAlarm
B 14	Number of paths	6		exp3NrPath
B 15	Deviation of SoS 1	F6080	%	exp3abwVos1
B 16	Deviation of SoS 2	F6082	%	exp3abwVos2
B 17	Deviation of SoS 3	F6084	%	exp3abwVos3
B 18	Deviation of SoS 4	F6086	%	exp3abwVos4
B 19	Deviation of SoS 5	F6088	%	exp3abwVos5
B 20	Deviation of SoS 6	F6090	%	exp3abwVos6
B 21	Deviation of SoS 7	F6092	%	exp3abwVos7
B 22	Deviation of SoS 8	F6094	%	exp3abwVos8
B 23	Path velocity 1	F6200	m/s	exp3v1
B 24	Speed of sound 1	F6020	m/s	exp3vos1
B 25	Signal acceptance 1	u7000	%	exp3siqAk1
B 26	Signal-to-noise AB1	F6640	dB	exp3SNRAB1
B 27	Signal-to-noise BA1	F6660	dB	exp3SNRBA1
B 28	Automatic gain AB 1	F6040	dB	exp3AGCAB1
B 29	Automatic gain BA 1	F6060	dB	exp3AGCBA1
B 30	Path velocity 2	F6202	m/s	exp3v2
B 31	Speed of sound 2	F6022	m/s	exp3vos2
B 32	Signal acceptance 2	u7001	%	exp3siqAk2
B 33	Signal-to-noise AB2	F6642	dB	exp3SNRAB2

**Figure 181: Modbus register list in the ERZ2000-NG with closed (left) and opened (right) calibration switch**



**Figure 182: Subdirectories of Instance F menu V in the ERZ2000-NG**

### 5.4.13 OX RMGView Trigger

#### OX RMGView Trigger

Access Line	Designation	Value	Unit	Variable
D	1	Parameter changes	72	<a href="#">cparCnt</a>
D	2	Number of freezes	4	<a href="#">frzCnt</a>
D	3	Error bit table	39	<a href="#">errBTCnt</a>
D	4	Format/Unit	0	<a href="#">xsqCnt</a>
D	5	Extra messages	0	<a href="#">ktkMsgCnt</a>
D	6	Visibilities	121981	<a href="#">visCnt</a>
K	10	Magic number 1	61543	<a href="#">magicRMG1</a>
K	11	The R of RMG	82	<a href="#">RofRMG</a>
K	12	The M of RMG	77	<a href="#">MofRMG</a>
K	13	The G of RMG	71	<a href="#">GofRMG</a>
K	14	The Blank	32	<a href="#">BlankofRMG</a>
K	15	Devive ID	1003	<a href="#">myRMGVtype</a>
K	16	Magic number 2	61543	<a href="#">magicRMG2</a>

Refresh

**Figure 183: Menu OX RMGView trigger**

The ERZ2000-NG can be coupled to an external computer via Modbus exclusively for internal purposes. The internal PC user interface "RMGView<sup>ERZ</sup>" visualizes the device data and enables remote parameterization.

The coordinates of **Menu OX RMGView trigger** contain auxiliary value (e.g. for totalizer) in order to keep the values displayed by the user interface and display the value dynamically.

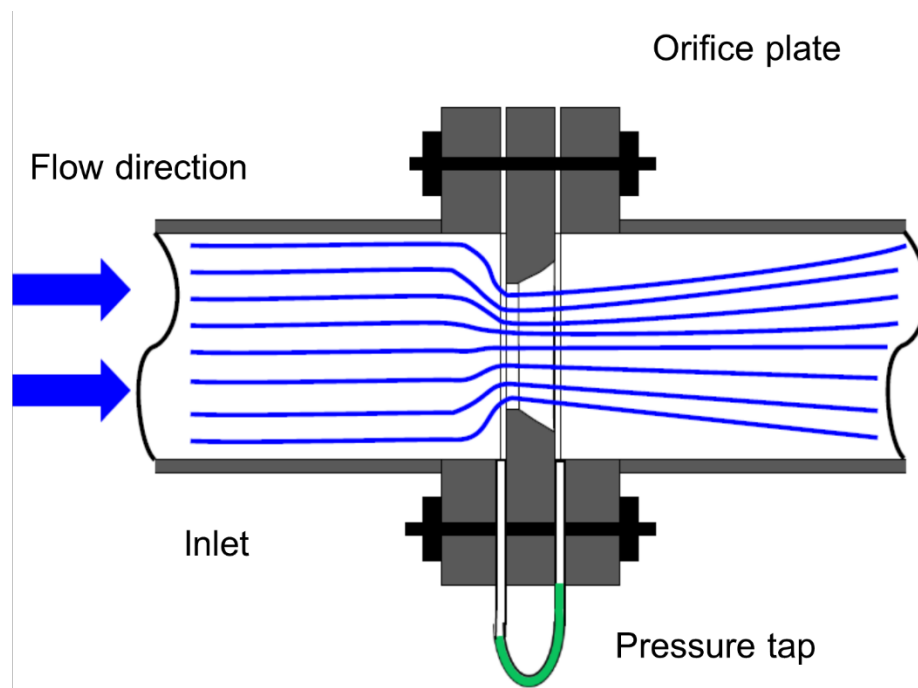
## 5.5 Orifice plate diameter

Flow rate measurement with a reduced flow cross-section is a prevalent method used for fluids, vapors and gases. In generally, it is a very durable method with which very high accuracy can be achieved with the requisite effort. The method is used in official custody transfer applications and is often used as a reference for other methods. After initial measuring ranges of 1:2 to 1:3, a larger pressure range of measuring ranges from 1:30 to 1:50 is possible with more precise pressure probes (usually only 1:3 to 1:10 in official custody transfer applications). Details are defined in the standard ISO 5167-1 / 2:2003 (previously DIN 1952), as well as in DVI 2041 for special applications.

249

As a flow measuring device, the narrowing as an orifice plate is usually implemented as a component of an orifice plate measuring segment. The flow rate detection takes place with the differential pressure built up via the orifice plate. For correct flow rate calculation, knowledge of the viscosity, density and isentropic exponent is necessary.

*Figure 184: Orifice plate flow rate meter measuring principle clarifies the measuring principle.*



**Figure 184: Orifice plate flow rate meter measuring principle**

With greater speed fluctuations in gases, the density and temperature change associated with the pressure change are considered. The following applies for an ideal gas:

$$\frac{p}{\rho} + gz + \frac{1}{2}v^2 + c_v T = \text{const}$$

↑  $\approx 0$

Where

- $v$  - Fluid speed
- $g$  - Gravitation constant
- $p$  - Pressure
- $\rho$  - Density
- $z$  - Geostatic height
- $c_v$  - Specific heat capacity of the gas with constant volume
- $T$  - Absolute temperature of the gas
- $\text{const}$  - Constant value

250

The differential pressure arising in the throat is referred to as effective pressure and can be converted to the flow rate. A sharp edge at the inlet and a concentric arrangement of the hole in the tube are important for the standard orifice plate.

### Note

**A significant difference to other measuring principles is that an orifice plant and/or orifice plate measuring segment is suitable for official custody transfer calibrations but does not have to be calibrated.**

If the design conforms to ISO 5167, the material values of the gas and the pressure differential of the flow rate can be calculated from the geometry of the throttle elements with accuracies of up to 0.2 %.

### Note

**Orifice plates should not be operated under 50 mm and with Reynolds numbers under 5000 (both relative to the inside pipe diameter).**

The ERZ2000-NG must be switched over to a suitable type before an orifice plate measurement takes place (see *chapter 1.5.1 Device type adjustment*). The "orifice plate" must be adjusted in coordinate **GB16 Volume transmitter mode**.

The special case of a revision for orifice plate measurements is presented in *appendix Special case of revision with orifice flow*.

### 5.5.1 GA Tube dimensions

#### GA Tube dimensions

Access Line	Designation	Value	Unit	Variable
A *	1 orifice diam.(T)	100.0000	mm	dt
A *	2 Pipe diam. (T)	150.0000	mm	lwt
D	3 T-crr.fact. orifice	1.000000		kdt
D	4 T-crr.fact. pipe	1.000000		klwt
E *	5 lin.expans. orifice	16.500	10 <sup>-6</sup> /°C	kdtLin
E *	6 lin.expans. pipe	11.000	10 <sup>-6</sup> /°C	klwtLin
E *	7 orifice diameter	100.0000	mm	blende20
E *	8 Pipe diameter	150.0000	mm	nennweite
E *	10 Substance orifice	OFF		kdtWsg
E *	11 Substance pipe	OFF		klwtWsg
E *	12 Orifice a0-coeff.	15.600		GOSTdA0
E *	13 Orifice a1-coeff.	8.300		GOSTdA1
E *	14 Orifice a2-coeff.	-6.500		GOSTdA2
E *	15 Tube a0-coeff.	11.100		GOSTlwA0
E *	16 Tube a1-coeff.	7.700		GOSTlwA1
E *	17 Tube a2-coeff.	-3.400		GOSTlwA2
A *	18 avg.orifice.diam.	100.0000	mm	dtMiwT
E *	19 avg.operating.temp.	15.00	K	miwT

Figure 185: Menu GA Tube dimensions

Menu GA Tube dimensions enables settings of the orifice plate parameters (for the ERZ2014-NG, ERZ2114-NG, ERZ2012-NG and ERZ2112-NG).

The neck is defined at 20°C in coordinates GA07 and GA08.

The temperature correction of the orifice plate diameter and the inside pipe diameter takes place in accordance with VDI/VDE 2040, sheet 2 (chapter 10) of April 1987.

There are two calculation methods, one of which is based on the linear heat expansion coefficient and the other is based on a proximity equation with coefficient selection depending on the materials for the orifice plate and pipe, which can be adjusted in coordinates GA10 and GA11. The following table shows the selection options.

<b>GA10 Substance orifice GA11 Substance pipe</b>		
<b>Selection options</b>	<b>Coefficients</b>	
	<b>A</b>	<b>B</b>
<b>Off</b>	-	-
<b>Linear</b>	-	-
<b>GOST</b>	-	-
<b>Steel I</b>	12.60	0.0043
<b>Steel II</b>	12.42	0.0034
<b>Steel III</b>	12.05	0.0035
<b>Steel IV</b>	10.52	0.0031
<b>Steel V</b>	17.00	0.0038
<b>Steel VI</b>	16.30	0.0116
<b>Bronze SnBz4</b>	17.01	0.0040
<b>Copper E-Cu</b>	16.13	0.0038
<b>Gunmetal Rg9</b>	16.13	0.0038
<b>Brass Ms63</b>	17.52	0.0089
<b>Nickel</b>	14.08	0.0028
<b>Hastelloy C</b>	10.87	0.0033

**Table 7: Temperature correction for orifice plate and pipe**

### **Off**

The corresponding temperature correction is switched off.

### **Linear**

The correction factor **GA03 T-crr.fact. orifice** or **GA04 T-crr.fact. pipe** is calculated with the linear heat expansion coefficient **GA05 lin.expans. orifice** or **GA06 lin.expans. pipe**.

$$GA03 = 1 + GA05 \cdot (T - 20)$$

The temperature  $T$  is relative to °C; the Pipe T-calc.fact takes place analogously.

### **Material selection**

The correction factor **GA03 T-crr.fact. orifice** or **GA04 T-calc.fact pipe** is calculated with a proximity equation and coefficients A and B.

$$GA03 = 1 + (A \cdot (T - 20) + B \cdot (T - 20)^2) \cdot 10^{-6}$$

The coefficients in *Table 7: Temperature correction for orifice plate and pipe* are assigned automatically with selection of a material. The permissible temperature range for the listed materials extends from -200°C to 600°C; the maximum temperature for copper, nickel and brass is 500°C.

### **GOST**

The correction takes place according to the requirements of GOST 8.586 for the flow rate and quantity measurement of fluids and gases with normal throttle devices.

8.586.1 Part 1 Principle of the measuring process and general requirements

8.586.2 Part 2 Technical requirements for orifice plates

8.586.5 Part 5 Measurement methodology

The calculation works with three coefficients  $a_0$ ,  $a_1$  and  $a_2$ , depending on the materials for orifice plate and pipe (coordinates **GA12**...**GA17**). Reference is only made here to the indicated documents for the description of the method.

**GA18** specifies the diameter of the throttle opening at the mean operating temperature, which is specified in **GA19**.

### 5.5.2 AP diff.pressure

#### AP diff.pressure

Access	Line	Designation	Value	Unit	Variable
A *	1	volume calculation	0.00	mbar	dpabr
D	2	Range	underdriven		range
D	3	volume via	Cell 1		slimg
D	4	cooperation	good		situat
D	5	Decision	Sure		decis
D	6	Overlap 1/2	partial		lapp12
D	7	Overlap 2/3	partial		lapp23
G *	9	Unit	mbar		dpQ/m
E *	10	Operating mode	OFF		dpMod
Q	11	dp formula check	20.00	mbar	dpTst
E *	12	zero point noise	0.00	mbar	dpNull
E *	13	min. dif. press.	1.00	mbar	dpMin
E *	14	max. dif. press.	500.00	mbar	dpMax
A *	15	Cell 1 diff. press	0.00	mbar	dp1m
A *	16	Cell 1 input	(...)		dp1mQI
D	17	act. dp1 offset	0.00	mbar	aktDp1Offs
E *	18	Cell 1 source	OFF		dp1mInp
E *	19	dp 1 at 4mA	0.00	mbar	dp1mK0
E *	20	dp 1 at 20mA	5.50	mbar	dp1mK1
E *	21	dp 1 correction	0.00	mbar	dp1Korr
A *	22	Cell 2 diff. press	0.00	mbar	dp2m
A *	23	Cell 2 input	(...)		dp2mQI
D	24	act. dp2 offset	0.00	mbar	aktDp2Offs
E *	25	Cell 2 source	OFF		dp2mInp
E *	26	dp 2 at 4mA	5.00	mbar	dp2mK0
E *	27	dp 2 at 20mA	55.00	mbar	dp2mK1
E *	28	dp 2 correction	0.00	mbar	dp2Korr
A *	29	Cell 3 diff. press	0.00	mbar	dp3m
A *	30	Cell 3 input	(...)		dp3mQI
D	31	act. dp3 offset	0.00	mbar	aktDp3Offs
E *	32	Cell 3 source	OFF		dp3mInp
E *	33	dp 3 at 4mA	50.00	mbar	dp3mK0
E *	34	dp 3 at 20mA	550.00	mbar	dp3mK1
E *	35	dp 3 correction	0.00	mbar	dp3Korr
D	36	Mean for DSfG	0.00	mbar	dpFmiw
D	37	Current status	Stop		dpCFstt
D	38	DSfG status	Stop		dpFstt
D	39	Used range	0.00	mbar	dpMb
G *	40	Format	%b.2f		dpFrm
D	41	Min. drag indicator	0.00	mbar	dpMn
D	42	Max. drag indicator	0.00	mbar	dpMx
D	43	Current gradient	0.00	mbar/s	dpGdt
D	44	Second mean	0.00	mbar	dpSmiw
D	45	Minute mean	0.00	mbar	dpMmiw
D	46	Hourly mean	0.00	mbar	dpHmiw
D	47	Ongoing mean	0.00	mbar	dpCFmiw
D	48	Standard deviation	0.00	mbar	dpStAb
D	49	Revision mean	0.00	mbar	dpRmiw
D	50	act. dp-digital	0.00	mbar	dpDigi
D	51	digital - analog	0.00	mbar	digMinAna
D	52	HART-correction	0.00	mbar	dpKorGI
E *	53	Max.perm.A/H-corr.	1.00	mbar	dpKorZul
E *	54	Manufacturer	Rosemount		dpManuf
E *	55	Device type	3051CA		dpGerTp
E *	56	Serial number 1	0		dpSerN1
E *	57	Serial number 2	0		dpSerN2
E *	58	Serial number 3	0		dpSerN3
F	61	volume calculation	0.00	mbar	dpabr
F	62	volume via	Cell 1		slimg
F	63	Cell 1 diff. press	0.00	mbar	dp1m
F	64	Cell 2 diff. press	0.00	mbar	dp2m
F	65	Cell 3 diff. press	0.00	mbar	dp3m
F	66	Cell 1 input	0		dp1mQI
F	67	Cell 2 input	0		dp2mQI
F	68	Cell 3 input	0		dp3mQI

Enter Cancel Load defaults Refresh

Figure 186: Menu AP differential pressure



The sensor signals of the delta-p measuring cells are connected via a 4...20 mA connection directly to the flow computer in this operating mode. The evaluation of signals can take be analog or digital (HART). The measuring cells are preferably operated in transmitter mode. For this purpose, the ERZ2000-NG provides the 24 V DC supply voltage.

In order to activate the volume calculation via the delta-p signals, the orifice plate operating mode must be set in coordinate GB16 in menu **G Meter** in the coordinate **GB Flow rate parameters**. In order for the meter calculation to take place via the delta-p signals, one of device types ERZ2014, 2114, 2012 or 2112 must be selected.

The parameters for the delta-p pressure transducers are adjusted in chapter **AP diff. pressure**. The following parameters are available for 3 measuring cells:

**AP01** to **AP07** show general information about the selected measuring ranges and about the interplay of the measuring cells in the transition from smaller to the next larger measuring cell.

The operating mode is adjusted in coordinate AP10. The following is available:

Off	Transmitter switched off
Analog 1 range	Analog measurement with 1 cell (4 ... 20 mA)
Analog 2 range	Analog measurement with 2 cells (4 ... 20 mA)
Analog 3 range	Analog measurement with 3 cells (4 ... 20 mA)
Digital 1 range	Digital measurement with 1 cell (HART)
Digital 2 range	Digital measurement with 2 cells (HART)
Digital 3 range	Digital measurement with 3 cells (HART)
Ana/Dig 1 range	Analog and digital measurement with 1 cell *
Ana/Dig 2 range	Analog digital measurement with 2 cells *
Ana/Dig 3 range	Analog digital measurement with 3 cells *
Formalism check	to check the flow rate equations, calculation can take place in this operating mode with a delta-p default instead of the measurement value.

\* In this operating mode, the faster, analog measurement is used for the calculation and, parallel to this, the slow, digital measurement is used for control and calibration of the analogue value. Therefore, a flow rate calculation can be achieved with the speed of the analog signal (7 cycles per second) based on the accuracy of the digital signal.

In this operating mode, the ERZ2000-NG performs an automatic, permanent calibration of the analog input. The value in coordinate **AP51** defines the permissible range for the automatic calibration.

A differential pressure for testing the flow rate equation is entered in coordinate **AP11 dp formula check** (only possible in formula check mode). This function simulates the differential pressure and replaces the measured value.

The value in coordinate **AP12 Zero point noise** specifies the differential pressure that should be suppressed by ERZ2000-NG (the effect corresponds to a leak volume limit, see *chapter 5.1.2 GB Flow rate parameters*).

The lower limit and thus the minimum flow rate  $Q_{b \min}$  (displayed in **GB02**) is calculated from the minimum permissible effective pressure of the orifice plate **AP13 min. dif. pressure**.

### Note

The minimum effective pressure  $dp_{\min}$  is a fixed value.  $Q_{b \min}$  also depends on the other status variables (living value).

The upper limit of the permissible effective pressure of the orifice plate **AP14 max. dif. pressure** is also a fixed value and can be converted to the maximum flow rate  $Q_{b \max}$  (living value).  $Q_{b \max}$  is displayed in **AP02**.

The measurements and parameters for cells 1, 2 and 3 are shown in *Table 8: Measurements and parameters for cells 1, 2 and 3* below.

Cell 1	Cell 2	Cell 3	Meaning
AP15	AP22	AP29	Cell 1 diff. press
AP16	AP23	AP30	Cell 1 input
AP17	AP24	AP31	act. dp 1/2/3 offset
AP18	AP25	AP32	Source assignment to current input 1, 2, ...6
AP19	AP26	AP33	delta-p 1/2/3 at 4 mA (lower figure limit)
AP20	AP27	AP34	delta-p 1/2/3 at 20 mA (upper figure limit)
AP21	AP28	AP35	delta-p 1/2/3 correction (offset correction)

**Table 8: Measurements and parameters for cells 1, 2 and 3**

Coordinates **AP36** to **AP49** contain defaults about mean values, DSfG values, etc. They are identical to the coordinates of other inputs, such as e.g. measurement pressure or measurement temperature. Coordinate **AP50 act. dp-digital** shows the currently measured delta-p value of the HART input (digital value). As already documented, there may be small differences between the digital and analog measurement value, which are displayed in coordinate **AP 51 digital-analog**. The correction calculated from this (based on the HART measurement) (**AP52 Hart-correction**) is shown in **AP52** and permanently corrected online.

Coordinates AP53 to AP58 are provided for inclusion of sensor data (manufacturer, type plate, etc.)

### Note

For the optimal operating mode of the ERZ2000-NG as an orifice flow meter, the second A/D converter available in the device is commissioned in order to ensure a quick delta-p measurement in parallel to the measurement of pressure and temperature.

For this purpose, the user must switch to *chapter 2.7.7.1 Inputs (current inputs)* of the selected channel and the parameter measuring strategy must be set to effective pressure (attention: access reserved for super users only).

257

### Example:

Current input 4 should measure the small cell

=> Chapter ND Current input 4 terminal X6-1, X6-2

**Coordinate ND09** includes the parameter **Measuring strategy**. The parameter for the flow computer operation is set to standard by default. Please set this parameter to **diff. pressure** for orifice plate flow computers. This setting must be repeated for all current inputs which are selected for delta-p measuring cells.

Please operate the inputs for pressure and temperature, and/or all measuring cells which are not used for delta-p on **standard**.

Refer to the relevant notices for the pressure transducer for activation of the HART operating mode of the delta-p transducer.

### 5.5.3 Special case zero point calibration of all delta-p cells

The ERZ2000-NG provides a function for offset correction with flow rate zero in the orifice plate computer operating mode. This makes a simple calibration of a zero point drift of the delta-p cells possible.

258

#### Requirements:

The ERZ2000-NG is notified via contact input or Modbus register that the measuring rail is closed and the flow rate must be zero. The differential pressure caused by a zero point drift must be smaller than the value defined by the leak volume limit (coordinate **AP12 Zero point noise**). If the differential pressure is greater, the "Flow with closed rail" alarm is generated. The calibration lock must be opened in order to be able to carry out the offset correction. The correction can only take place with manual intervention.

#### Example:

Under **G Meter** in menu **GH Start-up/Slow-down monitoring** next to the slider run time in coordinate **GH07 Source**, the source is selected, which notifies the ERZ2000-NG when flow is zero.

The menu offers:

"Off"	= no function
"Contact input 1 to 8"	= one of the 8 contact inputs delivers the information
"Modbus"	= Modbus register (9201) delivers the information

The current status (open / closed) is displayed in coordinate **GH06 pipe state**. The content of Modbus register 9201 (open/closed status) is displayed in coordinate **GH08 Modbus pipe state**. Parameterization of whether the flow status through closed rail is reported as alarm or warning takes place in coordinate **GH09 Action**.

In the example, contact input 5 should deliver the message. If all conditions for zero flow are fulfilled and the differential pressure remains low, chapter **AP Diff. pressure** must be selected for activation of the zero point calibration. Coordinate **AP33 dp 3 at 4 mA** shows the differential pressure caused by the zero point drift. The correction can be initiated via operation on the front panel and is carried out by pressing the **Enter key** with open calibration switch and simultaneous display of coordinate **AP33**.

Menu **GV Orifice** shows some of the adjusted and calculated values.

**GV Orifice**

Access Line	Designation	Value	Unit	Variable
A *	1 Qm flow rate	0.00	m3/h	qbWg
A *	2 diff.pressure	0.000	mbar	dp
A *	3 Reynolds number	0		Re
A *	4 Diameter ratio	0.000000		beta
A *	5 Expansion factor	0.000000		epsilon
A *	6 vel.of.approach	0.000000		edin
A *	7 Coef. of discharge	0.000000		cdin
A *	8 flow coefficient	0.000000		alpha
A *	9 Pressure loss	0.000	mbar	omega
E *	10 tapping	corner		
E *	11 method of calc.	ISO5167 (2003)		
E *	12 Serial number	0		brusewa
D	14 Iterations	0		iter
D	15 volume slice	.000000	m3	wgZykMng
D	16 time slice	0.000000	s	wgTZyk

Serial number of the orifice meter

Enter Cancel Load defaults Refresh

Figure 187: Menu GV Orifice

Corner, flange or D-D/2 can be selected for coordinate **GV10 tapping**. In **GV11 method of calc.**, all various data is based on ISO5167 the last is from the 2003. The serial number of the orifice meter should be entered in **GV12**.

**GW Extremal values for expanded type plate**

Access Line	Designation	Value	Unit	Variable
D	1 C at Dp-max	0.000000		CdExpMx
D	2 Re at Dp-max	0		ReExpMx
D	3 Qe at Dp-max	46857.1	kW	QeExpMx
D	4 Qms at Dp-max	35000.00	kg/h	QmExpMx
D	5 Qn at Dp-max	5099.82	m3/h	QnExpMx
D	6 Qm at Dp-max	1000.000	m3/h	QuExpMx
D	11 C at Dp-min	0.000000		CdExpMn
D	12 Re at Dp-min	0		ReExpMn
D	13 Qe at Dp-min	0.0	kW	QeExpMn
D	14 Qms at Dp-min	0.00	kg/h	QmExpMn
D	15 Qn at Dp-min	0.00	m3/h	QnExpMn
D	16 Qm at Dp-min	0.000	m3/h	QuExpMn

Refresh

Figure 188: Menu GW Extremal values for expanded type plate

Menu GV Orifice plate shows some **GW Extremal values** of the **Orifice calculation** for an **expanded type plate**. **GW01** shows the flow rate coefficient C and **GW02** shows the Reynolds number  $Re_D$  in the design point of the orifice meter. **GW04** and **GW05** contain the maximum mass flow rate and the maximum flow rate at base conditions. **GW14** and **GW15** show the corresponding minimum values.

260

### GX Roughness of tube

Access Line	Designation	Value	Unit	Variable
A *	1	Correct. factor	0.000000	KRau
D	2	Friction factor	0.000000	lambd
D	3	Friction fct. ref.	0.000000	lambdS
E *	4	Roughness-corr.	OFF	KRauMod
E *	5	Equiv. Roughness	0.150	mm requiv
D	6	Roughness	0.000000	mm ra
D	7	Lower margin	0.000000	mm raMin
D	8	Upper margin	0.000000	mm raMax
D	9	Correction	Switched off	raState

Enter Cancel Load defaults Refresh

**Figure 189: Menu GX Pipe roughness**

**GX Roughness of tube** influences the velocity profile and thus the flow rate depending on delta-p. If this correction is activated (**GX04**), a correction for the roughness entered in **GX05** is considered according to GOST (see below).

### GY Abrasion of orifice edge

Access Line	Designation	Value	Unit	Variable
A *	1	Correct. factor	0.000000	KEIK
D	2	Life time	0.000000	Years rElKa
D	3	Ongoing radius	0.000000	mm rElKk
E *	4	Mode	OFF	ElKmod
E *	5	Point in time	01-01-1970 01:00:00	rElKI
E *	6	Beginning radius	0.000000	mm rElKh
E *	7	Default value	1.000000	KEIKVg

Enter Cancel Load defaults Refresh

**Figure 190: Menu GY Abrasion of orifice edge**

If "Calculation" is set in coordinate **GY04** (instead of "off" or "default"), the abrasion of orifice edge according to GOST is factored in. For this purpose, **GY05 Point in time** of the determination of **GY06 Beginning radius** of the inside diameter of the orifice plate must be defined.

The correction of the pipe roughness and the abrasion of orifice edge takes place according to the requirements of GOST 8.586 for the flow rate and quantity measurement of fluids and gases with normal throttle devices, as described in chapter 5.5.1 GA Tube dimensions.

**GZ Orifice function key**

Designation	Value	Unit	Column	Jump target
Qm	0.00	m3/h	GV	<a href="#">Orifice</a>
dp1	0.00	mbar	AP	<a href="#">diff.pressure</a>
	underdriven			
Beta	0.000000		GV	<a href="#">Orifice</a>
Eps	0.000000			
E	0.000000			
C	0.000000			

Refresh

**Figure 191: Menu GZ Orifice function key**

Current values are displayed in this menu.

## 6 Parameter of the gas

Various physical properties of the gas which make the detection and determination / calculation more elaborate than the flow rate determination of liquids must be taken into account for the flow rate measurement of gases. The key parameters for the flow rate measurement of gases are summarized below; in the process, differentiation takes place between values measured directly, such as the individual gas components and derived values. Normally, gas models are required for the calculation of derived values which are also briefly described.

### 6.1 Direct gas parameters

Ultimately, the energy content of the gas is essential in the flow rate determination of natural gas. This is determined in various models. In the process – depending on the model – only a few parameters are required in part (e.g. for GERG 88 S calculation, see below). This includes calorific value and (standard) density and the share of CO<sub>2</sub>, N<sub>2</sub> and H<sub>2</sub> in the gas composition. The gas components are specified in "BA Components mode".

#### 6.1.1 BA Components mode

##### BA Components mode

Access Line	Designation	Value	Unit	Variable
E *	1	CO2 oper. mode	Default	co2Mod
E *	2	H2 oper. mode	Default	h2Mod
E *	3	N2 oper. mode	Default	n2Mod
E *	4	Op.mode other comp.	Default	kmpMod
G *	5	Unit	mole%	kmpDim
G *	6	Format	%.4f	kmpFrm
A *	7	Unnorm. sum	99.9999	mole% KnzSum
D	8	Component error	00000000	hex kompoErr
D	9	Evaluation	Okay	kompoState
T	10	Norm. tolerance	100.00	% sumZulAbw
E *	11	Balance method	total balanced	balance

Enter Cancel Load defaults Refresh

**Figure 192: Menu BA Component mode**

The following are available as setting values for the 4 default values:



CO2	H2	N2	Change operating mode In the case of AGA 8 92 DC, the operating mode for all other components should be ad- justed here.
Off	Off	Off	Off
Default	Default	Default	Default
DSfG	DSfG	DSfG	DSfG
RMG bus		RMG bus	RMG bus
Polynomial 1st order	Polynomial 1st order	Polynomial 1st order	-
Polynomial 2nd order	Polynomial 2nd order	Polynomial 2nd order	-
Polynomial 3rd order	Polynomial 3rd order	Polynomial 3rd order	-
4-20mA coeff.	4-20mA coeff.	4-20mA coeff.	-
0-20mA coeff.	0-20mA coeff.	0-20mA coeff.	-
4-20mA limit	4-20mA limit value	4-20mA limit value	-
0-20mA limit	0-20mA limit value	0-20mA limit value	-
Table value	Table value	Table value	Table value
-	Estimated analysis	Estimated analysis	Estimated analysis
Modbus	Modbus	Modbus	Modbus
Random	Random	Random	Random
EGO-Modbus	EGO-Modbus	-	-
-	RMG bus-24K	-	RMG bus-24K
Univ.Modb.Master	Univ.Modb.Master	-	Univ.Modb.Master

263

**Table 9: Settings for the default values, lines 1-4**

The shares of the gas components are normally standardized to 2 types at 100 %:

<b>Total calibration</b>	The gas shares are recalculated so that all shares combined result in exactly 100 %.
<b>Methane calibration</b>	The individual gas shares are deducted from the total share (100 %); the remainder is defined as the methane share.

In particular, a small error (e.g. due to formatting) can arise in the standardization after receipt of data, which must be entered as a tolerance. However, renewed standardization is advantageous.

The determination of additional gas components is required for the other normal model descriptions of the gas.

## 6.1.2 BB Carbon dioxide

**BB Carbon dioxide**

Access Line	Designation	Value	Unit	Variable
A *	1 Norm.mol.fraction	0.9960	mole%	co2
A *	2 Input value -> BB05	0.9960	mole%	co2Qll
A *	3 Cur.meas.cond.	Default		co2Btr
B	5 Default	<input type="text" value="0.9960"/>	mole%	co2Vq
B	6 Lower warning limit	<input type="text" value="0.0000"/>	mole%	co2WGwu
B	7 Upper warning limit	<input type="text" value="20.0000"/>	mole%	co2WGwo
E *	8 Lower alarm limit	<input type="text" value="0.0000"/>	mole%	co2AGwu
E *	9 Upper alarm limit	<input type="text" value="20.0000"/>	mole%	co2AGwo
E *	11 Coefficient 0	<input type="text" value="0"/>		co2K0
E *	12 Coefficient 1	<input type="text" value="0"/>		co2K1
E *	13 Coefficient 2	<input type="text" value="0"/>		co2K2
E *	14 Coefficient 3	<input type="text" value="0"/>		co2K3
E *	16 Source	<input type="text" value="OFF"/>		co2Inp
E *	17 Correction value	<input type="text" value="0.0000"/>	mole%	co2Korr
E *	19 Max. gradient	<input type="text" value="10"/>	mole%/s	co2MGdt
D	20 Timeout	3600	s	co2ToMx
D	21 Base value	0.9960	mole%	co2Orq
D	22 Mean for DSfG	0.9960	mole%	co2Emiw
D	23 Mass fraction	2.6136	weight%	GewpCo2
D	24 Volume fraction	0.9921	vol%	VolpCo2
D	27 Current status	Fixed value		co2CEstt
D	28 DSfG status	Fixed value		co2Estt
D	29 Used range	25.0000	mole%	co2Mb
D	31 Min. drag indicator	0.9960	mole%	co2Mn
D	32 Max. drag indicator	25.9960	mole%	co2Mx
D	33 Current gradient	0.0000	mole%/s	co2Gdt
D	34 Second mean	0.9960	mole%	co2Smiw
D	35 Minute mean	0.9960	mole%	co2Mmiw
D	36 Hourly mean	0.9960	mole%	co2Hmiw
D	37 Ongoing mean	0.9960	mole%	co2CEmiw
D	38 Standard deviation	0.0000	mole%	co2StAb
T	39 Table value 1	<input type="text" value="6.2000"/>	mole%	co2Tb1
T	40 Table value 2	<input type="text" value="1.0000"/>	mole%	co2Tb2
T	41 Table value 3	<input type="text" value="1.0000"/>	mole%	co2Tb3
T	42 Table value 4	<input type="text" value="1.0000"/>	mole%	co2Tb4
D	43 Running timeout	0	s	co2ToAct
D	44 Unnorm.mol.fraction	0.9960	mole%	co2Unrm
D	47 Revision mean	0.9960	mole%	co2Rmiw
D	48 retain value	0.9960	mole%	co2LW
D	49 Daily mean	1.0651	mole%	co2Tmiw
E *	50 Manufacturer	<input type="text" value="RMG"/>		co2Manuf
E *	51 Device type	<input type="text" value="GC"/>		co2GerTp
E *	52 Serial number	<input type="text" value="0"/>		co2SerNr
F	61 Norm.mol.fraction	0.9960	mole%	fco2
F	62 Input value	0.996	mole%	fco2Qll

Figure 193: Menu BB Carbon dioxide

Many parameters already presented in the preceding chapters have not been explained yet. Lines 2 and 5 are linked together; a default value can be entered in line 5, which is then taken as a basis if the value runs beyond the alarm limits.

Since the operation mode is set to default, the source is switched off; in addition to off, the current inputs 1-12, frequency inputs 1-8 and the input possibility via HART are also available with current inputs 1-12.

There is a drag pointer function for all measurements, separately for minimum and maximum peak values. The drag pointer contents can be reset selectively (pressing the Enter key) or globally (in the display function).

The representation structure is identical for **BC Hydrogen** and **BD Nitrogen**. Therefore, the same explanations also apply, so the presentation is not repeated.

### 6.1.3 BE Methane

#### BE Methane

Access Line	Designation	Value	Unit	Variable
A *	1 Norm.mol.fraction	95.1156	mole%	meth
A *	3 Cur.meas.cond.	Default		methBtr
B	5 Default	95.1155	mole%	methVg
B	6 Lower warning limit	70.0000	mole%	methWGwu
B	7 Upper warning limit	100.0000	mole%	methWGwo
D	21 Base value	95.1156	mole%	methOrg
D	23 Mass fraction	90.9831	weight%	GewpMeth
D	24 Volume fraction	95.1576	vol%	VolpMeth
D	34 Second mean	95.1156	mole%	methSmiw
T	39 Table value 1	100.0000	mole%	methTb1
T	40 Table value 2	100.0000	mole%	methTb2
T	41 Table value 3	100.0000	mole%	methTb3
T	42 Table value 4	100.0000	mole%	methTb4
D	44 Unnorm.mol.fraction	95.1155	mole%	methUnrm
D	47 Revision mean	95.1156	mole%	methRmiw
D	48 retain value	95.1156	mole%	methLW
F	61 Norm.mol.fraction	95.1156	mole%	fmeth

Enter Cancel Load defaults Refresh

Figure 194: Menu BE Methane

Methane has the greatest share in natural gas, in which can be up to 99 %. The display here also has a similar layout to the display for CO<sub>2</sub>, but it is reduced to the essential elements. The same explanations as above apply.

The representations and explanations of the following gases (**BF ethane, BG propane, BH N-butane, BI I-butane, BJ N-pentane, BK I-pentane, BL neo-pentane, BM hexane, BN heptane, BO octane, BP nonane, BQ decane, BR hydrogen sulphide, BS water, BT helium, BU oxygen, BV carbon monoxide, BW ethene, BX propene, BY argon**), which are or may be present in a smaller portion in natural gas, are not shown, because they have an identical layout.

266

## 6.2 Additional gas values

The following parameters are from menu "A Measurements". In the process, many values are not direct measurements; rather, they are derived from other measurement variables. The menus of these values have the same structure as the menus of the other measurements (see *chapter 4.2 Pressure transducer* and *4.3 Temperature transducer*)

6.2.1 AD Superior calorific value

**AD Superior calorific value**

Access Line	Designation	Value	Unit	Variable
A *	1 Measured value	9.188	kWh/m3	ho
A *	2 Input value -> EF01	1		hoQll
E *	3 Operating mode	Table value		hoMod
G *	4 Unit	kWh/m3		hoDim
B	5 Default	11.250	kWh/m3	hoVg
B	6 Lower warning limit	8.000	kWh/m3	hoWGwu
B	7 Upper warning limit	14.000	kWh/m3	hoWGwo
E *	8 Lower alarm limit	7.000	kWh/m3	hoAGwu
E *	9 Upper alarm limit	14.000	kWh/m3	hoAGwo
E *	10 Coefficient 0	0		hoK0
E *	11 Coefficient 1	0		hoK1
E *	12 Coefficient 2	0		hoK2
E *	13 Coefficient 3	0		hoK3
E *	19 Source	OFF		hoInp
E *	21 Correction value	0.000	kWh/m3	hoKorr
E *	22 Max. gradient	10	kWh/m3/s	hoMGdt
D	23 Timeout	3600	s	hoToMx
D	24 Base value	9.188	kWh/m3	hoOrg
D	25 Mean for DSFG	9.188	kWh/m3	hoEmiw
D	27 Current status	Fixed value		hoCEstt
D	28 DSFG status	Fixed value		hoEstt
D	29 Used range	2.062	kWh/m3	hoMb
G *	30 Format	%0.3f		hoFrm
D	31 Min. drag indicator	9.188	kWh/m3	hoMn
D	32 Max. drag indicator	11.250	kWh/m3	hoMx
D	33 Current gradient	0.000	kWh/m3/s	hoGdt
D	34 Second mean	9.188	kWh/m3	hoSmiw
D	35 Minute mean	9.188	kWh/m3	hoMmiw
D	36 Hourly mean	9.188	kWh/m3	hoHmiw
D	37 Ongoing mean	9.188	kWh/m3	hoCEmiw
D	38 Standard deviation	0.000	kWh/m3	hoStAb
T	39 Table value 1	9.188	kWh/m3	hoTb1
T	40 Table value 2	10.000	kWh/m3	hoTb2
T	41 Table value 3	10.000	kWh/m3	hoTb3
T	42 Table value 4	10.000	kWh/m3	hoTb4
D	43 Running timeout	0	s	hoToAct
D	44 Holding value	11.250	kWh/m3	hoHalte
E *	45 Hs of test gas	11.061	kWh/m3	hoPruef
E *	46 Max.perm.corr.val.	0.300	kWh/m3	hoKorrZul
D	47 Revision mean	9.188	kWh/m3	hoRmiw
D	48 retain value	9.188	kWh/m3	hoLW
D	49 Daily mean	10.957	kWh/m3	hoTmiw
E *	50 Manufacturer	RMG		hoManuf
E *	51 Device type	GC		hoGerTp
E *	52 Serial number	0		hoSerNr
F	61 Measured value	9.188	kWh/m3	fho
F	62 Input value	1		fhoQll

Figure 195: Menu AD Superior calorific value

**AD02:** An arrow after the input value indicates the origin of the value – in this case, from the default of **AD05**, because the operating mode is set to "default". A different operating mode can be selected in **AD03** (e.g. from default, DSfG, RMG bus, lin. frequency response, 1st order polynomial, 2nd order polynomial, 3rd order polynomial, 4-20mA coeff., 0-20mA coeff., 4-20mA limit value, 0-20mA limit value, table value, ISO 6976, Modbus, GPA 2172-96, EGO Modbus, univ.Modb.master).

If, for example, a different operating mode is selected, e.g. the reference to a current input, which is assigned under **AD19**, a jump to there can take place directly via the link, i.e. the link "[NA01](#)" (single click), see *Figure 196: Menu AD Calorific value, different operating mode*.

### AD Superior calorific value

Access Line	Designation	Value	Unit	Variable
A *	1 Measured value	11.250	kWh/m <sup>3</sup>	<a href="#">ho</a>
A *	2 Input value -> <a href="#">NA01</a>	0.0026	mA	<a href="#">hoQil</a>
E *	3 Operating mode	4-20mA lim. ▾		<a href="#">hoMod</a>
G *	4 Unit	kWh/m <sup>3</sup>		<a href="#">hoDim</a>
B	5 Default	11.250	kWh/m <sup>3</sup>	<a href="#">hoVg</a>
B	6 Lower warning limit	8.000	kWh/m <sup>3</sup>	<a href="#">hoWGwu</a>
B	7 Upper warning limit	14.000	kWh/m <sup>3</sup>	<a href="#">hoWGwo</a>
E *	8 Lower alarm limit	7.000	kWh/m <sup>3</sup>	<a href="#">hoAGwu</a>
E *	9 Upper alarm limit	14.000	kWh/m <sup>3</sup>	<a href="#">hoAGwo</a>
E *	10 Coefficient 0	0		<a href="#">hoK0</a>
E *	11 Coefficient 1	0		<a href="#">hoK1</a>
E *	12 Coefficient 2	0		<a href="#">hoK2</a>
E *	13 Coefficient 3	0		<a href="#">hoK3</a>
E *	19 Source	Current 1 ▾		<a href="#">hoInp</a>
E *	21 Correction value	0.000	kWh/m <sup>3</sup>	<a href="#">hoKorr</a>
E *	22 Max. gradient	10	kWh/m <sup>3</sup> /s	<a href="#">hoMGdt</a>
D	23 Timeout	3600 s		<a href="#">hoToMx</a>

**Figure 196: Menu AD Calorific value, different operating mode**

When the operation mode is set to default, the source is switched off (i.e. set to "off"); otherwise, the current inputs 1-12, frequency inputs 1-8 and the input possibility via HART can also be selected with current inputs 1-12.

The value specified in **AD44** is maintained at a constant level while the test gas is activated. **AD46** specified the maximum permissible deviation.

## 6.2.2 AE Standard density

### AE Standard density

Access Line	Designation	Value	Unit	Variable
A *	1 Measured value	0.75651	kg/m3	rhon
A *	2 Input value -> AE05	0.75651	kg/m3	rhonQll
E *	3 Operating mode	Default		rhonMod
G *	4 Unit	kg/m3		rhonDim
B	5 Default	0.75651	kg/m3	rhonVq
B	6 Lower warning limit	0.60000	kg/m3	rhonWGWu
B	7 Upper warning limit	1.00000	kg/m3	rhonWGWo
E *	8 Lower alarm limit	0.70000	kg/m3	rhonAGwu
E *	9 Upper alarm limit	1.00000	kg/m3	rhonAGwo
E *	10 Coefficient 0	0.8		rhonK0
E *	11 Coefficient 1	-94		rhonK1
E *	12 Coefficient 2	-97		rhonK2
E *	13 Coefficient 3	0.01		rhonK3
E *	19 Source	OFF		rhonInp
E *	20 2nd source ref	OFF		rhonInp2
E *	21 Correction value	0.00000	kg/m3	rhonKorr
E *	22 Max. gradient	10	kg/m3/s	rhonMGdt
D	23 Timeout	3600	s	rhonToMx
D	24 Base value	0.75651	kg/m3	rhonOrg
D	25 Mean for DSfG	0.75651	kg/m3	rhonEmiw
A *	26 2nd input value	(....)		rhonQll2
D	27 Current status	Fixed value		rhonCEstt
D	28 DSfG status	Fixed value		rhonEstt
D	29 Used area	1.00000	kg/m3	rhonMb
G *	30 Format	%0.5f		rhonFrm
D	31 Min. drag indicator	0.75651	kg/m3	rhonMn
D	32 Max. drag indicator	1.75651	kg/m3	rhonMx
D	33 Current gradient	0.00000	kg/m3/s	rhonGdt
D	34 Second mean	0.75651	kg/m3	rhonSmiw
D	35 Minute mean	0.75651	kg/m3	rhonMmiw
D	36 Hourly mean	0.75651	kg/m3	rhonHmiw
D	37 Ongoing mean	0.75651	kg/m3	rhonCEmiw
D	38 Standard deviation	0.00000	kg/m3	rhonStAb
T	39 Table value 1	0.89690	kg/m3	rhonTb1
T	40 Table value 2	0.80000	kg/m3	rhonTb2
T	41 Table value 3	0.80000	kg/m3	rhonTb3
T	42 Table value 4	0.80000	kg/m3	rhonTb4
D	43 Running timeout	0	s	rhonToAct
D	44 Holding value	0.75651	kg/m3	rhonHalte
E *	45 sd of test gas	0.71750	kg/m3	rhonPruef
E *	46 Max.perm.corr.val.	0.30000	kg/m3	rhonKorrZul
D	47 Revision mean	0.75651	kg/m3	rhonRmiw
D	48 retain value	0.75651	kg/m3	rhonLW
D	49 Daily mean	0.76013	kg/m3	rhonTmiw
E *	50 Manufacturer	RMG		rhonManuf
E *	51 Device type	GC		rhonGerTp
E *	52 Serial number	0		rhonSerNr
F	61 Measured value	0.75651	kg/m3	fihon
F	62 Input value	0.75651	kg/m3	fihonQll

Enter Cancel Load defaults Refresh

Figure 197: Menu AE Standard density

The 2<sup>nd</sup> source can be selected under **AE20** for standard density transmitters with 2 frequencies. Further explanations can be omitted, because the menu has the exact same structure as the previous menu.

### 6.2.3 LU Quantity weighted average values

#### LU Quantity weighted average values

Access	Line	Designation	Value	Unit	Variable
D	1	Hs run. hour	11.250	kWh/m3	<a href="#">hoCHMiw</a>
D	2	sd run. hour	0.75651	kg/m3	<a href="#">rhonCHMiw</a>
D	3	den run. hour	35.000	kg/m3	<a href="#">rhobCHMiw</a>
D	4	Hs last hour	9.188	kWh/m3	<a href="#">hoLHMiw</a>
D	5	sd last hour	0.75651	kg/m3	<a href="#">rhonLHMiw</a>
D	6	den last hour	35.000	kg/m3	<a href="#">rhobLHMiw</a>
D	7	Hs run. day	11.250	kWh/m3	<a href="#">hoCDMiw</a>
D	8	sd run. day	0.75651	kg/m3	<a href="#">rhonCDMiw</a>
D	9	den run. day	35.000	kg/m3	<a href="#">rhobCDMiw</a>
D	10	Hs last day	10.957	kWh/m3	<a href="#">hoLDMiw</a>
D	11	sd last day	0.76013	kg/m3	<a href="#">rhonLDMiw</a>
D	12	den last day	35.000	kg/m3	<a href="#">rhobLDMiw</a>

Refresh

**Figure 198: Menu LU Quantity weighted average values**

Quantity-weighted mean values are formed for superior calorific value, standard density and density. The average values arise from the division of hourly quantities or daily quantities:

$$\text{superior calorific value} = \frac{\text{energy quantity}}{\text{volume at base conditions quantity}}$$

$$\text{standard density} = \frac{\text{mass quantity}}{\text{volume at base conditions quantity}}$$

$$\text{density} = \frac{\text{mass quantity}}{\text{volume at measurement conditions quantity}}$$

In the process, the quantity weighting depends on the type of quantity determination:

- from current hourly quantities
- from quantities of the last hour
- from current daily quantities
- from daily quantities of the last day



## 6.2.4 AF Relative density

### AF Relative density

Access Line	Designation	Value	Unit Variable
A *	1 Measured value	0.5549	<a href="#">dv</a>
A *	2 Input value -> <a href="#">AF05</a>	0.5549	<a href="#">dvQll</a>
E *	3 Operating mode	Default <input type="text"/>	<a href="#">dvMod</a>
B	5 Default	0.5549 <input type="text"/>	<a href="#">dvVg</a>
B	6 Lower warning limit	0.5000 <input type="text"/>	<a href="#">dvWGwu</a>
B	7 Upper warning limit	1.0000 <input type="text"/>	<a href="#">dvWGwo</a>
E *	8 Lower alarm limit	0.5000 <input type="text"/>	<a href="#">dvAGwu</a>

271

Figure 199: Menu AF Relative density

The density of air is set to the value  $d_v = 1$  for the density ratio. Light gases (such as  $H_2$  [ $d_v = 0.07$ ], methane [ $d_v = 0.553$ ], ...) have a value less than 1 ( $d_v < 1$ ), heavy gases (e.g. propane [ $d_v = 1.529$ ],  $CO_2$  [ $d_v = 1.537$ ], ...) have a value greater than 1 ( $d_v > 1$ ).

It is important to consider how the density transmitter outputs the value  $d_v$ ; normally reference to the standard density of air at  $0^\circ C$  and 1,013.25 mbar applies. Further explanations can be omitted, because the menu has the exact same structure as the previous menu.

## 6.2.5 AG Density

The density is the density of the gas under measurement conditions, i.e. under the prevailing pressure and the prevailing temperature. Due to the identical structure of the preceding menus, no further representations and explanations are provided here.

## 6.2.6 AH Temperature of the density transmitter

The temperature also has an influence on the density, so it must also be measured. Due to the identical structure of the preceding menus, no further representations and explanations are provided here.

## 6.2.7 AI Temperature for VOS correction

An additional parameter which is characteristic for the gas composition is the velocity of sound. This is abbreviated as VOS (velocity of sound) or SOS (speed of sound). It depends on pressure, temperature and density. Due to the identical structure of the preceding menus, no further representations and explanations are provided here.

### 6.2.8 AJ Velocity of sound at measurement conditions

The velocity of sound is based on the present conditions (density or pressure and temperature). Due to the identical structure of the preceding menus, no further representations and explanations are provided here.

### 6.2.9 AK Velocity of sound at base conditions

The velocity of sound at base conditions is based on a pressure of 1,013 mbar and a temperature of 0°C. Due to the identical structure of the preceding menus, no further representations and explanations are provided here.

### 6.2.10 AM Viscosity

The viscosity describes the resistance of the gas to flow. Due to the identical structure of the preceding menus, no further representations and explanations are provided here.

### 6.2.11 AN Isentropic exponent

The isentropic exponent (formula symbol:  $\kappa$ ) is the exponent of the equation

$$p \cdot V^\kappa = \text{const.}$$

for the isotropic status change (no change of entropy, i.e. no removal or addition of heat) of an ideal gas. Due to the identical structure of the preceding menus, no further representations and explanations are provided here.

### 6.2.12 AO Joule-Thomson coefficient

The Joule-Thomson effect describes the temperature change of gas with a change in pressure. The magnitude and direction of the temperature change are described by the Joule-Thomson coefficient  $\mu$ :

$$\mu = \left( \frac{\partial T}{\partial p} \right)_{\text{isentropic}}$$

**Note**

The Joule-Thomson coefficient  $\mu$  can be positive or negative. For air, the temperature increases with a pressure increase (heating up of the valve with an air pump) and decreases as pressure decreases. With natural gas, the Joule-Thomson coefficient  $\mu$  has the same algebraic sign; the temperature decreases as pressure decreases. In order to prevent adverse effects of the gas pressure regulating system due to excessively low temperatures, the compressed gas is often preheated.

273

Due to the identical structure of the preceding menus, no further representations and explanations are provided here.

## 6.3 C Analysis

The gas analysis specifies various gas models that can be used in the ERZ2000-NG. There are brief explanations of when the various models are and should be used. These models are provided to enable calculation of the derived values.

274

### 6.3.1 CA Overview (Analysis function key)

#### CA Analysis function key

Designation	Value	Unit	Column	Jump target
	AGA 8 92DC		CC	<a href="#">K coefficient</a>
	5.0998		CB	<a href="#">Conversion factor</a>
K	0.99175		CH	<a href="#">AGA 8 92DC</a>
Z	0.989229			
Zb	0.997457			
CO2	0.9960	mole%	CN	<a href="#">C6+-Distribution</a>
H2	1.0000	mole%		
N2	0.2988	mole%		
CH4	95.1156	mole%		
C2H6	1.7928	mole%		
C3H8	0.4482	mole%		
N-C4	0.0996	mole%		
I-C4	0.0996	mole%		
N-C5	0.0299	mole%		
I-C5	0.0498	mole%		
C6	0.0697	mole%		
C7	0.0000	mole%		
C8	0.0000	mole%		
C9	0.0000	mole%		
C10	0.0000	mole%		
H2S	0.0000	mole%		
H2O	0.0000	mole%		
He	0.0000	mole%		
O2	0.0000	mole%		
CO	0.0000	mole%		
Ar	0.0000	mole%		

Refresh

**Figure 200: Menu "CA Analysis function key"**

Some of the adjusted and used data for gas calculation is specified in the overview:

- The adjusted method for calculation of gas parameters – in this case, AGA 8 92DC
- Value of the K coefficient
- Value of the status coefficient
- Value of the Z coefficient
- Volume shares of various gas components

275

Further details for these parameters can also be opened via the various jump destinations.

### 6.3.2 CB Conversion factor

#### CB Conversion factor

Access	Line	Designation	Value	Unit	Variable
A *	1	Conversion factor -> <a href="#">CB03</a>	5.0998		<a href="#">Zu</a>
A *	3	Conv.fact.(P,T,K)	5.0998		<a href="#">Zzahl</a>
A *	4	C.fact.(R,Sd)	46.2651		<a href="#">Zwert</a>
G *	8	Format	%. <b>4f</b>		<a href="#">ZuFrm</a>
D	31	Min. drag indicator	0.9190		<a href="#">ZuMn</a>
D	32	Max. drag indicator	9.3584		<a href="#">ZuMx</a>
D	34	Second mean	5.0998		<a href="#">ZuSmiw</a>
D	35	Minute mean	5.0998		<a href="#">ZuMmiw</a>
D	36	Hourly mean	5.0998		<a href="#">ZuHmiw</a>
D	38	Standard deviation	0.0000		<a href="#">ZuStAb</a>
D	47	Revision mean	5.0998		<a href="#">ZuRmiw</a>
F	61	Conversion factor	5.09982		<a href="#">fZu</a>

**Figure 201: CB Status coefficient**

The dimensionless factor C describes the ratio of a gas volume at base conditions to the gas volume at measurement conditions.

### 6.3.3 CC Calculation of K coefficient

#### CC Calculation of K coefficient

Access Line	Designation	Value	Unit	Variable
A *	1	K coefficient	<b>0.99175</b>	<a href="#">kzl</a>
A *	2	Compr.factor(M)	<b>0.989229</b>	<a href="#">ZBetr</a>
A *	3	Compr.factor(B)	<b>0.997457</b>	<a href="#">ZNorm</a>
A *	4	R(K,Sd,T,p)	<b>3.858</b>	kg/m3 <a href="#">rbCalc</a>
E *	5	Calc. method	AGA 8 92DC	<a href="#">kMod</a>
E *	6	Default	1	<a href="#">kVg</a>
G *	7	Format	<b>%0.5f</b>	<a href="#">kzlFrm</a>
E *	8	Kind of gas	Erdgas	<a href="#">medium</a>
B	9	AGA control	Boundless	<a href="#">gasCtrl</a>
D	10	AGA range	PQG p<10Mpa	<a href="#">agaRange</a>
D	11	GQ1/2 calculation	AGA 8 92DC	<a href="#">agaGerg</a>
D	12	Propane-Criterion	complied	<a href="#">C3Krit</a>
D	13	Butane+-Criterion	complied	<a href="#">C4PKrit</a>
B	14	G486 Msg. active	Yes	<a href="#">q486Krit</a>
D	15	EOS-algorithm	3	<a href="#">kalgoB</a>
D	31	Min. drag indicator	0.93566	<a href="#">kzlMn</a>
D	32	Max. drag indicator	1.00059	<a href="#">kzlMx</a>
D	34	Second mean	0.99175	<a href="#">kzlSmiw</a>
D	35	Minute mean	0.99175	<a href="#">kzlMmiw</a>
D	36	Hourly mean	0.99175	<a href="#">kzlHmiw</a>
D	38	Standard deviation	0.00000	<a href="#">kzlStAb</a>
D	47	Revision mean	0.99175	<a href="#">kzlRmiw</a>
F	61	K coefficient	0.99175	<a href="#">fkzl</a>
F	62	Compr.factor(M)	0.989229	<a href="#">fZBetr</a>
F	63	Compr.factor(B)	0.997457	<a href="#">fZNorm</a>

Enter Cancel Load defaults Refresh

**Figure 202: CB Calculation of K coefficient**

The selection of the gas model, i.e. the calculation method for determination of the compressibility coefficient (K coefficient) used for determination of the official custody-transfer results takes place in **CC05 Calc. method**.

There are several options available to choose from here:

- K constant
- Ideal gas

The simplest possibility is when the same measuring gas is always used, then K = constant. If this value is known, it can be entered as a default value.

For an "ideal gas", which can be assumed at low pressures, K = 1.

- GERG 88 S

- GERG 88 S set B
- GERG 88 S set C
- AGA8 Gross Meth.1
- AGA8 Gross Meth.2
- AGA NX 19 L
- AGA NX 19 H

In order to be able to apply GERG 88 S, the calorific value ( $H_s$ ) and standard density ( $sd$ ) of the gas must be known and the share of carbon dioxide ( $CO_2$ ) and the share of hydrogen ( $H_2$ ) of the gas composition must be known. In the American sphere, this corresponds to AGA 8 Gross Method 1.

If, in addition to the calorific value ( $H_s$ ) and standard density ( $sd$ ), the share of hydrogen ( $H_2$ ) and the share of nitrogen ( $N_2$ ) of the gas composition are known, GERG 88 S set B can be used.

If, in addition to the standard density ( $sd$ ) the share of carbon dioxide ( $CO_2$ ), the share of hydrogen ( $H_2$ ) and the share of nitrogen ( $N_2$ ) of the gas composition are known, GERG 88 S set C should be applied. In the American sphere, this corresponds to AGA 8 Gross Method 2.

**Note**

**Strictly speaking, GERG 88 S is an extension of the AGA 8 Gross Methods for the case that the share of hydrogen  $H_2$  cannot be disregarded ( $H_2 > 0$ ). The AGA 8 Gross Method only corresponds to GERG 88 S if there is no hydrogen in the gas ( $H_2 = 0$ ).**

A revised AGA 8 as AGA NX 19 L finds application specifically for L-gas (natural gas with a low energy content). Another revision, AGA NX 19 H applies for H-gas (natural gas with a high energy content).

More extensive knowledge of the gas composition is necessary for the following methods, which, for example can be provided by a gas chromatograph.

- AGA 8 (1985)
- AGA 8 92DC

AGA (85) from 1985 is a first description of a gas in consideration of the individual gas components. This model is practically never used any more.

AGA 8 92DC is currently chosen for "normal" natural gas (status 2017).

- GC1/GC2

GC1 / GC2 means that the K coefficient method follows the respective active measuring device in case of a redundant addition of the gas characteristic.

**Example:**

The main measurement with a GC takes place with a full analysis and the K coefficient is calculated according to AGA 8 92 DC. The comparison measurement is a correlative measuring device and the K coefficient determination takes place in accordance with GERG 88 S.

The chromatographic main measurement is more precise, but a new measurement is only provided approximately every 5 minutes. By contrast, the less exact correlation can generate new measurements each second. If a changeover from the GC main measurement to the correlative comparison device takes place during a new measurement value determination, the method of the K coefficient calculation switches automatically from AGA 8 92 DC to GERG 88 S. If necessary, another billing mode (route) can also be selected for this case (for the setting, see menu EC Billing mode, line 4 Billing mode selection).

- Van Der Waals
- Beattie&Bridgeman
- Peng-Robinson

The last 3 gas models are based on expansions of the ideal gas equation. Van der Waals also factors the molecular weight and molecular volume into the ideal gas equation. Additional empirical parameters are required for this purpose. The Beattie-Bridgeman model requires 5 additional experimentally-determined constants. The last model finds application for gases and liquids and also requires additional parameters.

**Note**

**If the Peng-Robinson gas model is not explicitly selected, the converter is compliant in Germany MID. A change to Peng-Robinson requires official calibration authorization.**

The gas types are entered in line **CC08**. The quality range is checked for an AGA 8 92DC status coefficient calculation with the setting in **CC09 AGA Control**. The following tables specify the ranges:



Value	Pipeline Quality Gas (<10MPa)		Pipeline Quality Gas (<12MPa)		Wider Ranges of Application		Unit
	Min	Max	Min	Max	Min	Max	
Hs	30	45	30	45	20	48	MJ/m <sup>3</sup>
T	263	338	263	338	225	350	K
p	0	10	0	12	0	65	MPa
dv	0.55	80	0.55	80	0.55	90	-
Methane	70	100	70	100	50	100	mol-%
N <sub>2</sub>	0	50	0	20	0	50	mol-%
CO <sub>2</sub>	0	23	0	20	0	30	mol-%
Ethane	0	13	0	10	0	20	mol-%
Propane	0	6	0	3.5	0	5	mol-%
H <sub>2</sub> O	0	0.015	0	0.015	0	0.015	mol-%
H <sub>2</sub> S	0	0.02	0	0.02	0	0.02	mol-%
H <sub>2</sub>	0	10	0	10	0	10	mol-%
CO	0	3	0	3	0	3	mol-%
O <sub>2</sub>	0	0.02	0	0.02	0	0.02	mol-%
I-butane	0	1.5	0	1.5	0	1.5	mol-%
N-butane	0	1.5	0	1.5	0	1.5	mol-%
I-pentane	0	0.5	0	0.5	0	0.5	mol-%
n-pentane	0	0.5	0	0.5	0	0.5	mol-%
Hexane	0	0.1	0	0.1	0	0.1	mol-%
Heptane	0	0.05	0	0.05	0	0.05	mol-%
Octane	0	0.05	0	0.05	0	0.05	mol-%
Nonane	0	0.05	0	0.05	0	0.05	mol-%
Decane	0	0.05	0	0.05	0	0.05	mol-%
Helium	0	0.5	0	0.5	0	0.5	mol-%
Argon	0	0.02	0	0.02	0	0.02	mol-%

279

**Table 10: Quality range for various natural gas qualities**

The value **CC10 AGA validity** specifies the quality range in which AGA 8 DC 92 Status equation currently applies. ISO 12213 defines 3 ranges.

1. Pipeline Quality Gas <10 MPa
2. Pipeline Quality Gas <12 MPa
3. Wider Ranges of Application

If the current operating conditions are not adequate for "Wider ranges of application", this is also indicated here. Then a quality statement cannot be made.

In case of a violation of a pre-selected quality range, the message "H80-3 AGA8<>range" can be set (for this purpose, see the parameter [gasCtrl](#)). However, this is only logical if a full analysis is available.

280

The value **CC11 GC1/2 calculation** is only active in operating mode **CC05 = GERG 88 S**, AGA 8 92DC and GC1/GC2. In the first two cases it is constant for GERG 88 S resp. AGA 8 92DC. In operating mode GC1/GC2 (main and reference gas composition), its value is determined by whether the currently selected gas composition transmitter has a full analysis (then AGA 8 92DC) or not (then GERG 88 S). The value selects the status equation for the conversion and suppresses the error evaluation of the status equation not selected in each case. The value can also be used for control of the billing mode (see **EC04**).

**CC12 Propane criterion** tests the "third rule" (DVGW G486 1/3 rule) with respect to propane. The third rule checks whether the status coefficient calculation with GERG 88 S is permissible for a gas (see also **CC13**). The rule violation can be indicated with a message "H78-1 G486 violated, DVGW G486 (1/3 rule) violated. Gas is not GERG-compliant" (see also CC14).

**CC13 Butane+ criterion** tests the "third rule" with respect to butane and higher. The third rule checks whether the status coefficient calculation with GERG 88 S is permissible for a gas (see also **CC12**). The rule violation can be indicated with a message "H78-1 G486 violated, DVGW G486 (1/3 rule) violated. Gas is not GERG-compliant" (see also **CC14**).

**CC14 G486 mess. active** activates the message "H78-1 G486 violated, DVGW G486 (1/3 rule) violated. Gas is not GERG-compliant" in case of a violation of the third rule with respect to propane **CC12** and butane plus higher **CC13**. This is only logical if a full analysis is available.

6.3.4 GERG 88 S

**CD GERG equation of state**

Access Line	Designation	Value	Unit	Variable
A *	1	K coefficient	<b>0.99157</b>	<a href="#">KPgerg</a>
A *	2	Compr.factor(M)	<b>0.989008</b>	<a href="#">ZBgerg</a>
A *	3	Compr.factor(B)	<b>0.997413</b>	<a href="#">ZNgerg</a>
A *	4	R(K,Sd,T,p)	<b>3.859</b> kg/m3	<a href="#">RBgerg</a>
D	5	Percentage error	0.01789 %	<a href="#">PFgerg</a>
D	6	Consistency check	Okay	<a href="#">gerqKonsis</a>
E *	7	Limit mode	Default if LV	<a href="#">gerqErrMod</a>
E *	8	Limits	Sensor limits	<a href="#">gergRange</a>
A *	9	Input values	<b>Hs,Sd,CO2,H2</b>	<a href="#">gerqArqs</a>
D	12	rd for GERG	0.5851	<a href="#">dvGerg</a>
D	13	Hs for GERG	40.500 MJ/m3	<a href="#">HoGerg</a>
D	14	Mod.gas iterations	6	<a href="#">GIter</a>
D	15	P(B)iterations	1	<a href="#">PIterN</a>
D	16	P(M)iterations	1	<a href="#">PIterB</a>
D	17	Molar mass	16.9126 kg/kmole	<a href="#">molMGerg</a>
D	18	Hydrocarbon GERG	97.6618 mole%	<a href="#">grqFitch</a>
D	19	N2 GERG	0.2458 mole%	<a href="#">grqFitn2</a>
D	20	CO2 GERG	0.9960 mole%	<a href="#">grqFitco2</a>
D	21	H2 GERG	1.0000 mole%	<a href="#">grqFith2</a>
D	22	CO GERG	0.0964 mole%	<a href="#">grqFitco</a>
D	23	Hs hydrocarbon	923.90 kJ/mole	<a href="#">hGergTheo</a>

Enter Cancel Load defaults Refresh

Figure 203: Menu CD GERG 88 S

**CD06 Consistency check** determines and displays deviations in the selected calculation method (AGA 8 92 DC in this case).

Exceeded limit values are monitored in Germany exclusively with use of GERG 88 S. **CD07 Limit mode** can be used to determine how further calculation takes place in case of a limit value breach. If the limit value settings are exceeded (limit value mode), further calculation "calculating with LV" takes place with the "real values"; this is prescribed for official custody transfer applications in Germany. It is also possible to continue to calculate with the default values for the K coefficient, "Default if LV".

According to the German version (pipeline quality gas according to ISO 12213-3), "narrow" must be selected under **CD08 Limits** for official custody transfer applications with use of GERG 88 S. This corresponds to:

- T of -10 to 65°C
- P of 0 to 120 bar
- dv of 0.55 to 0.8
- Hs of 30 to 45 MJ/m<sup>3</sup>

CO<sub>2</sub> of 0 to 20 Mol%

H<sub>2</sub> of 0 to 10 Mol%

"wide" (corresponds to wider ranges of application according to ISO 12213-3) corresponds to:

282

T of -10 to 65°C

P of 0 to 120 bar

dv of 0.55 to 0.9

Hs of 20 to 48 MJ/m<sup>3</sup>

CO<sub>2</sub> of 0 to 30 Mol%

H<sub>2</sub> of 0 to 10 Mol%

"very wide" (corresponding to RMG-internal definition):

T of -15 to 70°C

P of 0 to 150 bar

dv of 0.38 to 1.16

Hs of 10 to 60 MJ/m<sup>3</sup>

CO<sub>2</sub> of 0 to 30 Mol%

H<sub>2</sub> of 0 to 30 Mol%

The standard limit values of the respective transmitters apply for other sensors.

**CD17** to **CD23** are internal intermediate values from the GERG equation.

### 6.3.5 CE AGA NX 19 equation of state

#### CE AGA NX 19 equation of state

Access Line	Designation	Value	Unit	Variable
A *	1	K coefficient	0.99155	<a href="#">KPagnxL</a>
A *	2	Compr.factor(M)	0.989006	<a href="#">ZBagnxL</a>
A *	3	Compr.factor(B)	0.997439	<a href="#">ZNaagnxL</a>
A *	4	R(K,Sd,T,p)	3.859	kg/m3 <a href="#">RBagnxL</a>
D	5	Percentage error	0.02073	% <a href="#">PFagnxL</a>
D	6	Consistency check	Okay	<a href="#">aqagnxState</a>
E *	7	Tau-calculation	492 °Ra	<a href="#">tauCalc</a>
E *	8	N2 rich gas	No	<a href="#">grubengas</a>
E *	9	with Rd factor	Yes	<a href="#">mitdvf</a>
E *	10	Rd source	From stand.dens.	<a href="#">dvSrc</a>

283

Figure 204: Menu CE AGA NX 19 equation of state

#### Note

Calculation of the K coefficient according to AGANX19 is also possible for nitrogen-rich natural gas with N2 content of up to 70 mol.%. Then, CE08 is set to "yes".

The representations and explanations of menus **CF AGA NX 19 equation of state with correction for H group gas** and **CG AGA 8 equation of state 1985** are omitted here; further information is provided in *chapter 6.3.3 CC Calculation of K coefficient*.

## 6.3.6 CH AGA 8 92DC equation of state

CH AGA 8 92DC equation of state

Access Line	Designation	Value	Unit	Variable
A *	1	K coefficient	<b>0.99175</b>	<a href="#">KPaga8dc</a>
A *	2	Compr.factor(M)	<b>0.989229</b>	<a href="#">ZBaga8dc</a>
A *	3	Compr.factor(B)	<b>0.997457</b>	<a href="#">ZNaga8dc</a>
A *	4	R(K,Sd,T,p)	<b>3.858</b> kg/m3	<a href="#">RBaga8dc</a>
D	5	Percentage error	0.00000 %	<a href="#">PFaga8dc</a>
D	6	Consistency check	Okay	<a href="#">aga8dcState</a>
A *	7	Calc.std.density	<b>0.75017</b> kg/m3	<a href="#">rhoneAga8dc</a>
A *	8	Calc.density	<b>3.826</b> kg/m3	<a href="#">rhobAga8dc</a>
D	9	High-temp. param.	0.000	<a href="#">HiTempPar</a>
D	10	Quadrupol param.	0.006872	<a href="#">QuadruPar</a>
D	11	Orientation param.	0.005316	<a href="#">OrientPar</a>
D	12	Energy parameter	157.9608 K	<a href="#">EnergyPar</a>
D	13	Size parameter	0.099850 m3/kmole	<a href="#">SizePar</a>
E *	14	Ethene assignment	Ethane ▾	<a href="#">etenZuord</a>
E *	15	Propene assignm.	Propane ▾	<a href="#">ppenZuord</a>
E *	16	Neo-pentane assignm.	N-pentane ▾	<a href="#">neopZuord</a>

Enter Cancel Load defaults Refresh

Figure 205: Menu CH AGA 8 92DC equation of state

The values of **CH09** to **CH13** are internal parameters for developers that are not normally relevant for "normal" users.

**CH14**, **CH15** and **CH16** specify the volume shares of corresponding gas components which are not normally determined by the GC, calculated according to defined distribution rules; the reference is given here.

The illustrations and explanations of menus **CI Beattie & Bridgeman equation of state** and **CJ Van Der Waals equation of state** are omitted here; further information is available in *chapter 6.3.3 CC Calculation of K coefficient*.

### 6.3.7 CK Industrial gases parameter

#### CK Industrial gases parameter

Access Line	Designation	Value	Unit	Variable
E *	1 Sel.industr.gases	CH4		<a href="#">techgas</a>
E *	2 A0 other gas	2.2769		<a href="#">tg_A0</a>
E *	3 a other gas	0.01855		<a href="#">tg_a</a>
E *	4 B0 other gas	0.05587		<a href="#">tg_B0</a>
E *	5 b other gas	-0.01587		<a href="#">tg_b</a>
E *	6 c other gas	128300		<a href="#">tg_c</a>
E *	7 Mol.mass other gas	16.043	kg/kmole	<a href="#">tg_molv</a>
E *	8 Tc other gas	190.56	K	<a href="#">tg_Tc</a>
E *	9 Pc other gas	45.98	bar	<a href="#">tg_Pc</a>

285

**Figure 206: Menu CK Industrial gases parameter**

The empirical parameters and experimentally determined constants for the Beattie-Bridgeman model are entered in this menu.

The illustrations and explanations of **menus CL AGA8 Gross methods** and **CM Z coefficient comparison** are omitted here; further information is available in *chapter 6.3.3 CC Calculation of K coefficient*.

## 6.3.8 CN C6+ -Distribution

CN C6+-Distribution

Access Line	Designation	Value	Unit	Variable
E *	1 C6+ distribution	No <input type="text"/>		<a href="#">c6pDistrib</a>
D	2 Weight hexane	100.00	%	<a href="#">partHexa</a>
E *	3 Weight heptane	0.00	%	<a href="#">partHept</a>
E *	4 Weight octane	0.00	%	<a href="#">partOct</a>
E *	5 Weight nonane	0.00	%	<a href="#">partNon</a>
E *	6 Weight decane	0.00	%	<a href="#">partDec</a>
A *	17 N2	0.2988	mole%	<a href="#">aq8N2</a>
A *	18 CO2	0.9960	mole%	<a href="#">aq8Co2</a>
A *	19 H2S	0.0000	mole%	<a href="#">aq8H2S</a>
A *	20 H2O	0.0000	mole%	<a href="#">aq8H2O</a>
A *	21 Helium	0.0000	mole%	<a href="#">aq8He</a>
A *	22 Methane	95.1156	mole%	<a href="#">aq8Meth</a>
A *	23 Ethane	1.7928	mole%	<a href="#">aq8Eth</a>
A *	24 Propane	0.4482	mole%	<a href="#">aq8Prop</a>
A *	25 N-butane	0.0996	mole%	<a href="#">aq8NBut</a>
A *	26 I-butane	0.0996	mole%	<a href="#">aq8IBut</a>
A *	27 N-pentane	0.0299	mole%	<a href="#">aq8NPen</a>
A *	28 I-pentane	0.0498	mole%	<a href="#">aq8IPen</a>
A *	29 Hexane	0.0697	mole%	<a href="#">aq8Hex</a>
A *	30 Heptane	0.0000	mole%	<a href="#">aq8Hept</a>
A *	31 Octane	0.0000	mole%	<a href="#">aq8Oct</a>
A *	32 Nonane	0.0000	mole%	<a href="#">aq8Non</a>
A *	33 Decane	0.0000	mole%	<a href="#">aq8Dec</a>
A *	34 O2	0.0000	mole%	<a href="#">aq8O2</a>
A *	35 CO	0.0000	mole%	<a href="#">aq8Co</a>
A *	36 H2	1.0000	mole%	<a href="#">aq8H2</a>
A *	37 Argon	0.0000	mole%	<a href="#">aq8Arg</a>

Enter Cancel Load defaults Refresh

Figure 207: Menu CN C6+ -Distribution

**CN01** defines whether the C6+ component mixture of the PGC is distributed for subsequent calculations of heptane, octane, nonane, and decane – "yes". The distribution takes place based on coordinates **CN0** to **CN06**. When "no" is the setting, no distribution takes place.

The volume shares are displayed in **CN17** to **CN37** for control purposes (distributed according to the distributor rule and counted up to 100% standardization); the K coefficient calculation is carried out with these values.

The illustrations and explanations of **menu CO Peng-Robinson status equation** are omitted; further information is available in *Kapitel 6.3.3 CC Calculation of K coefficient*.



## 6.4 D Calculated values

### 6.4.1 DA Calculations according to ISO 6976

#### DA Calculations in accordance with ISO 6976

Access Line	Designation	Value	Unit	Variable
A *	1	Standard density	<b>0.75020</b>	kg/m <sup>3</sup> <a href="#">rhon6976</a>
A *	2	Relative density	<b>0.5802</b>	<a href="#">dv6976</a>
A *	3	Sup.calorific.val.	<b>11.175</b>	kWh/m <sup>3</sup> <a href="#">ho6976</a>
A *	4	Inf. calor. value	<b>10.079</b>	kWh/m <sup>3</sup> <a href="#">hu6976</a>
A *	5	Wobbe superior	<b>14.6702</b>	kWh/m <sup>3</sup> <a href="#">wo6976</a>
A *	6	Wobbe inferior	<b>13.2316</b>	kWh/m <sup>3</sup> <a href="#">wu6976</a>
D	7	Hs->Hs(Tc25Tb0)	1.0000	<a href="#">hofiso</a>
D	8	Sd->Sd(Tb0)	1.0000	<a href="#">rnfiso</a>
D	9	rd->rd(Tb0)	1.0000	<a href="#">dvfiso</a>
D	10	Hi/Hs	0.9019	<a href="#">hudho</a>
D	11	Molar sup.cal.val.	899.374	kJ/mole <a href="#">homol</a>
D	12	Molar inf.cal.val.	811.183	kJ/mole <a href="#">humol</a>
D	13	Spec. gas constant	0.495747	kJ/kgK <a href="#">spezGasK</a>
D	14	compressibility	0.997425	<a href="#">cf6976</a>
D	15	Methane number	0.000	<a href="#">MZRg</a>
D	16	Methane no. range	Invalid	<a href="#">mzValid</a>
D	17	Sd dev. to ISO	0.00	% <a href="#">rhonAbw</a>
D	18	Hs dev. to ISO	0.00	% <a href="#">hoAbw</a>
B	19	Sd max.allowed.Dev.	<input type="text" value="1.00"/>	% <a href="#">rhonAbwZul</a>
B	20	Hs max.allowed.Dev.	<input type="text" value="1.00"/>	% <a href="#">hoAbwZul</a>
B	21	GQ control	<input type="text" value="No"/>	<a href="#">isoCtrl</a>
E *	22	ISO6976 Revision	<input type="text" value="2005"/>	<a href="#">isoVers</a>

Figure 208: Menu DA Calculations according to ISO 6976

If the gas composition is known with a determination with a GC, the calculation of standard density (**DA01**), sup. calorific value (**DA03**), Inf. calor. value (**DA04**) and Wobbe index take place according to the standard ISO 6976.

If applicable, the data of the gas analysis is required for an additional gas model, e.g. for gas transfer station at the border. It may then be the case that the PGC specifies other base conditions for its billing. In this case, DIN EN ISO 6976 must be activated and the base conditions are then corrected accordingly. In **DA26 ISO6976 Revision**, the year of publication of the standard can be selected, 2005 or 2016.

#### Note

The election of the year of publication of the standard DIN ISO 6976 - 2005 or 2016 - must correspond to the setting or specification by the PGC.

The selection of the latest version DIN EN ISO 6976:2016 usually results in only minor (rounding) deviations in the calculation compared to the previous version from 2005.

### Note

ISO 6976:2016 must only be activated if the model for determining gas composition utilises a complete gas analysis.

288

## 6.4.2 DB Calculation according to AGA10/Helmholtz ISO20765-1:2005

### DB Calculation according to AGA 10 / Helmholtz ISO20765-1:2005

Access	Line	Designation	Value	Unit	Variable
D	1	Internal energy	-160.201	kJ/kg	InErg
D	2	Free energy	59.963	kJ/kg	FrErg
D	3	Enthalpy	-16.438	kJ/kg	enthI
D	4	Free enthalpy	203.726	kJ/kg	FrenthI
D	5	Entropy	-0.7510	kJ/kgK	Entropie
D	6	Cv meas.cond.	1.6679	kJ/kgK	CVMixB
D	7	Cp meas.cond.	2.1920	kJ/kgK	CPMixB
D	8	Iseentr.exp.(M)	1.30006		KappaB
D	9	Calc.VOS(M)	432.3	m/s	vosAqaB
D	10	Joule-Thomson(M)	4.68995	K/MPa	jtkB
D	11	Cv base cond.	1.6202	kJ/kgK	CVMixN
D	12	Cp base cond.	2.1220	kJ/kgK	CPMixN
D	13	Iseentr.exp.(B)	1.30641		KappaN
D	14	Calc.VOS(B)	420.1	m/s	vosAqaN
D	15	Joule-Thomson(B)	5.45794	K/MPa	jtkN
E *	16	Standard for SOS	ISO20765-1:2005	▼	sosMod

Enter Cancel Load defaults Refresh

**Figure 209: Menu DB Calculation according to AGA 10 / Helmholtz ISO20765-1:2005**

Calculation according to AGA 10 / Helmholtz ISO20765-1:2005 allows for determination of parameters which are required for the orifice measurement.

In recent years, the number of flow meters for natural gas using an ultrasonic transit time difference method for medium and high pressures with medium and larger nominal widths has multiplied many times over. Many of these devices offer determination of the velocity of sound (VOS) by means of ultrasound.

If AGA 10 is also used for calculation of the velocity of sound based on the gas composition (**DB09**), 2 independent measurement values are available for control purposes:

- A change of the gas composition can be recognized  
This allows for a "quick" detection of change with the slow measurement determinations of a GC
- Malfunctions of the ultrasonic gas meter can be recognized.

**DB16** defines how the velocity of speed is calculated from a given gas composition; the following options are available: ISO20765-1:2005, GOST 8.662-2009 or AGA 10.

### 6.4.3 DC Transport phenomena

#### DC Transport phenomena

Access Line	Designation	Value	Unit	Variable
D 1	Dyn.viscosity(M)	11.8273	uPas	<a href="#">EtaBJSKV</a>
D 2	Dyn.viscosity(B)	10.2713	uPas	<a href="#">EtaNJSKV</a>
D 3	Kin.viscosity(M)	0.0034	stokes	<a href="#">kinVskB</a>
D 4	Kin.viscosity(B)	0.1358	stokes	<a href="#">kinVskN</a>
D 7	Molar mass	16.7717	kg/kmole	<a href="#">MJSKV</a>
E * 9	Database	JSKV plus		<a href="#">jskvMod</a>

Enter Cancel Load defaults Refresh

Figure 210: Menu DC Transport phenomena

In the process, the kinematic viscosity  $\nu$  arises from the dynamic viscosity  $\eta$  with simple division by the density  $\rho$ .

$$\nu = \frac{\eta}{\rho}$$

### 6.4.4 DD Critical values

#### DD Critical values

Access Line	Designation	Value	Unit	Variable
D 1	Temperature	193.68	K	<a href="#">TcJSKV</a>
D 2	Volume	0.1002	l/mole	<a href="#">VcJSKV</a>
D 3	Pressure	4.60064	MPa	<a href="#">PcJSKV</a>
D 4	Density	167.37013	kg/m3	<a href="#">RhocJSKV</a>
D 5	Viscosity	12.3907	uPas	<a href="#">EtacJSKV</a>
D 6	Compr.factor	0.28628		<a href="#">ZcJSKV</a>

Refresh

Figure 211: Menu DD Critical values

The values shown here are the key characteristic variables of the real gas. Normally, however, these values are not sufficient for determining the K coefficient.

### 6.4.5 DE Stoichiometry

290

#### DE Stoichiometry

Access Line	Designation	Value	Unit	Variable
D 1	Stoichiom.frac. C	1.0266		<a href="#">Stoech_C</a>
D 2	Stoichiom.frac. H	4.0073		<a href="#">Stoech_H</a>
D 3	Stoichiom.frac. N	0.0060		<a href="#">Stoech_N</a>
D 4	Stoichiom.frac. O	0.0199		<a href="#">Stoech_O</a>
D 5	Stoichiom.frac. S	0.0000		<a href="#">Stoech_S</a>
D 6	Stoichiom.frac. He	0.0000		<a href="#">Stoech_He</a>
D 7	Stoichiom.frac. Ar	0.0000		<a href="#">Stoech_Ar</a>
D 8	Molar mass	16.7717	kg/kmole	<a href="#">molMagaBdc</a>
D 9	Reactive part C	1.0166		<a href="#">reaktiv_C</a>
D 10	Reactive part H	4.0073		<a href="#">reaktiv_H</a>
D 11	H/C-ratio	3.9419		<a href="#">HdCratio</a>
D 12	approx octane no.	135.2		<a href="#">OZapx</a>
D 13	approx methane no.	100.5		<a href="#">MZapx</a>

**Figure 212: Menu DE Stoichiometry**

The umbrella term stoichiometry identifies an alternative method of breaking down a gas mixture into various components. The basis is the law of conservation of mass, i.e. an attempt is made to calculate the shares of the individual components from the total molecular mass. Basically, this is possible for one or very few gas components, particularly when the shares of part of the other components are already known. The greater the number of components that are present or unknown, the more difficult the breakdown becomes.

Stoichiometry can help in determining the shares of combustion products (next chapter) in case of complete combustion.

### 6.4.6 DF Environment

#### DF Impact on environment in the case of complete combustion

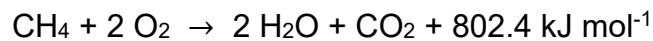
Access Line	Designation	Value	Unit	Variable
D 1	H2O per kWh (Hs)	0.1445	kg/kWh	<a href="#">chiEH2O</a>
D 2	CO2 per kWh (Hs)	0.1808	kg/kWh	<a href="#">chiECO2</a>
D 3	H2O per kWh (Hi)	0.1602	kg/kWh	<a href="#">chiHH2O</a>
D 4	CO2 per kWh (Hi)	0.2005	kg/kWh	<a href="#">chiHCO2</a>
D 5	CO2 emissionfactor	55.69	t CO2/TJ	<a href="#">spzCO2Emf</a>
D 10	CO2 emission	0.00	kg/h	<a href="#">Qco2</a>
D 11	combust. air dry	0.00	kg/h	<a href="#">QairD</a>
D 12	combust. air hum.	0.00	kg/h	<a href="#">QairH</a>

Refresh

**Figure 213: Menu DF Environment**

With the combustion of natural gas, more specifically methane (and some of the other carbon compounds), only hydrogen H<sub>2</sub>O and carbon dioxide CO<sub>2</sub> emerge as combustion products after complete combustion. In the process, the quantity of the greenhouse gas CO<sub>2</sub> produced is of interest.

Methane + air (oxygen) → water + carbon dioxide + energy



The calculated share of water / kWh is indicated in **DF01** and the share of carbon dioxide / kWh is indicated in **DF02**.

As a result, the share of greenhouse gas per kWh during combustion can be calculated (**DF04** and **DF05**).

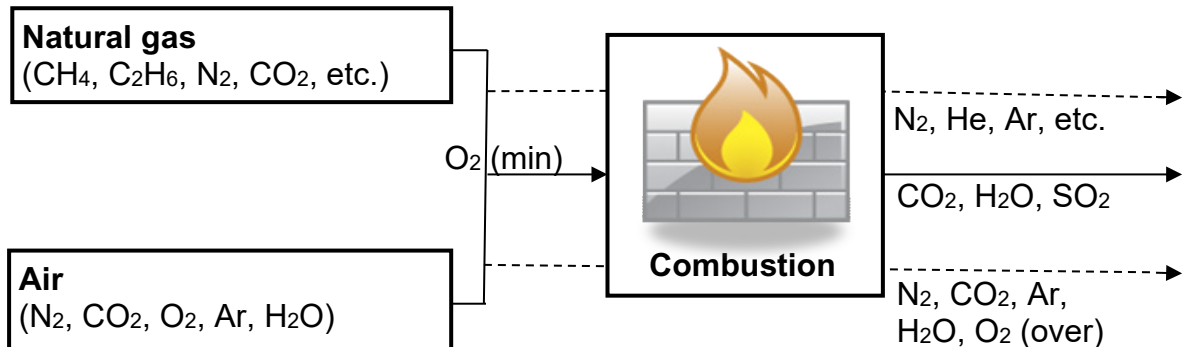
## 6.4.7 DJ Exhaust summary

DJ exhaust summary

Access Line	Designation	Value	Unit	Variable
D 1	H2O per 1 m3 gas	1.6146	kg/m3	<a href="#">chiMH2O</a>
D 2	CO2 per 1 m3 gas	2.0208	kg/m3	<a href="#">chiMCO2</a>
D 3	N2 per 1 m3 gas	0.0037	kg/m3	<a href="#">chiMN2</a>
D 4	SO2 per 1 m3 gas	0.0000	kg/m3	<a href="#">chiMSO2</a>
D 5	He fram nat.gas	0.0000	kg/m3	<a href="#">chiMHe</a>
D 6	Ar from nat.gas	0.0000	kg/m3	<a href="#">chiMAr</a>
D 10	O2-consumption	2.8890	kg/m3	<a href="#">chiVO2</a>
B 11	Air ratio	<input type="text" value="1.1015"/>		<a href="#">lambda</a>
D 12	Saturation vapor P	23.3557	hPa	<a href="#">pVapor</a>
B 13	Ambient temp.	<input type="text" value="20.00"/>	°C	<a href="#">tEnvi</a>
B 14	Ambient pressure	<input type="text" value="1015.00"/>	hPa	<a href="#">pAir</a>
B 15	Rel. air humidity	<input type="text" value="20.00"/>	%	<a href="#">relHumi</a>
D 16	O2 from air	3.1822	kg/m3	<a href="#">chiTO2</a>
D 17	N2 from air	10.3882	kg/m3	<a href="#">chiTN2</a>
D 18	CO2 from air	0.0069	kg/m3	<a href="#">chiTCO2</a>
D 19	Ar from air	0.1737	kg/m3	<a href="#">chiTAr</a>
D 20	H2O from air	0.0395	kg/m3	<a href="#">chiTH2O</a>
D 21	CO2 exhaust fume	2.0277	kg/m3	<a href="#">chiACO2</a>
D 22	N2 exhaust fume	10.3919	kg/m3	<a href="#">chiAN2</a>
D 23	Ar exhaust fume	0.1737	kg/m3	<a href="#">chiAAr</a>
D 24	H2O exhaust fume	1.6541	kg/m3	<a href="#">chiAH2O</a>
D 25	SO2 exhaust fume	0.0000	kg/m3	<a href="#">chiASO2</a>
D 26	He exhaust fume	0.0000	kg/m3	<a href="#">chiAHe</a>
D 27	O2 exhaust fume	0.2932	kg/m3	<a href="#">chiAO2</a>
D 28	Air consump. dry	13.7510	kg/m3	<a href="#">chiDair</a>
D 29	Air consump. hum	13.7905	kg/m3	<a href="#">chiHair</a>

**Figure 214: menu DJ Exhaust summary**

In menu **DJ Exhaust summary**, all (potentially) remaining or arising gases after the combustion of natural gas with oxygen in the air are listed, see *Figure 215: Combustion of natural gas with air*. This includes H<sub>2</sub>O and CO<sub>2</sub>, in particular.



**Figure 215: Combustion of natural gas with air**

**DJ01 to DJ06** are gas components originating from the exhaust gas, wherein helium and argon are not involved in the combustion process (noble gases). The ratio of the actually supplied to theoretically required air quantity for complete combustion is indicated in **DJ11**.

**DJ13 to DJ15** are data with which the share of water in the supplied air can be calculated.

**DJ16** indicates the quantity of airborne oxygen involved in the combustion.

**DJ17 to DJ20** indicate components of the supplied air that are not involved in the combustion; **DJ21 to DJ27** indicate the exhaust gas components arising during combustion.

## 6.4.8 DK Composition of exhaust fumes

### DK Composition of exhaust fumes

Access	Line	Designation	Value	Unit	Variable
D	1	CO2 humid	8.8203	mole%	<a href="#">EFco2</a>
D	2	N2 humid	71.0155	mole%	<a href="#">EFn2</a>
D	3	Ar humid	0.8326	mole%	<a href="#">EFar</a>
D	4	Vapor	17.5773	mole%	<a href="#">EFh2o</a>
D	5	SO2 humid	0.0000	mole%	<a href="#">EFso2</a>
D	6	He humid	0.0000	mole%	<a href="#">EFhe</a>
D	7	O2 humid	1.7543	mole%	<a href="#">EFo2</a>
D	10	CO2 dry	10.7013	mole%	<a href="#">ETco2</a>
D	11	N2 dry	86.1601	mole%	<a href="#">ETn2</a>
D	12	Ar dry	1.0101	mole%	<a href="#">ETar</a>
D	13	SO2 dry	0.0000	mole%	<a href="#">ETso2</a>
D	14	He dry	0.0000	mole%	<a href="#">EThe</a>
D	15	O2 dry	2.1284	mole%	<a href="#">ETo2</a>

Refresh

*Figure 216: Menu DK Composition of exhaust gas*

Menu **DK Composition of exhaust gas** lists the essential components of the exhaust gas which (can) arise during the combustion.

### Note

In parallel to the calculation of the exhaust gas values, an expansion with the 4 billing modes (4 totalizer sets) was implemented.

There is also the option of setting up this mode as a CO<sub>2</sub> totalizer in each of the 4 billing modes (routes).

A CO<sub>2</sub> totalizer can also be selected as a source for pulse outputs with the parameters of the pulse outputs.



### 6.4.9 DG Correction of velocity of sound

#### DG Correction of velocity of sound

Access Line	Designation	Value	Unit	Variable
A *	1 Rho corrected	35.0000	kg/m3	vskrRk
A *	2 Corr.factor RHO	1.00000		vskrG
A *	3 Current L	59.3500		vskrL
E *	5 VOS source value	At base conditions		vskrMod2
E *	6 L with cn, meas.	53.3600		vskrLB
E *	7 L with cn, base	59.3500		vskrLN
E *	8 cn calib.gas	431.1000	m/s	vskrCR
E *	9 Calib. temp.	0.00	°C	tyosKal
A *	11 Rho for VOS corr.	35.0000	kg/m3	rbFuerVskr
A *	12 VOS for corr.	431.1000	m/s	cFuerVskr

Enter Cancel Load defaults Refresh

295

Figure 217: Menu DG Correction of velocity of sound

The ERZ2000-NG offers a correction option for direct density meters when the velocity of sound in the gas is known. For this purpose, the actual velocity of sound (also abbreviated here as  $c_n$ ;  $c$  = velocity of sound under  $n$  = base conditions) must be entered in coordinate **DG08 cn calib.gas**. It is compared with the correct velocity of sound in **DG12 VOS for corr.** With the formula for an ideal gas

$$c = \sqrt{\kappa \frac{p}{\rho}}$$

Where

- $c_n$  - Velocity of sound
- $\kappa$  - Adiabatic exponent
- $p$  - Pressure
- $\rho$  - Density

a correction value can be determined for the density (**DG02 Corr.factor Rho**). With the path length along which the velocity of sound is determined, the change from base to measurement conditions can be factored in.

### 6.4.10 DH Assessed analysis

#### DH Assessed analysis

Access Line	Designation	Value	Unit	Variable	
D	1	N2	0.2877	mole%	<a href="#">apxN2</a>
D	2	CO2	0.9960	mole%	<a href="#">apxCo2</a>
D	3	H2S	0.0000	mole%	<a href="#">apxH2S</a>
D	4	H2O	0.0000	mole%	<a href="#">apxH2O</a>
D	5	Helium	0.0000	mole%	<a href="#">apxHe</a>
D	6	Methane	96.1634	mole%	<a href="#">apxMeth</a>
D	7	Ethane	1.8711	mole%	<a href="#">apxEth</a>
D	8	Propane	0.3369	mole%	<a href="#">apxProp</a>
D	9	N-butane	0.0608	mole%	<a href="#">apxNBut</a>
D	10	I-butane	0.1022	mole%	<a href="#">apxIBut</a>
D	11	N-pentane	0.0298	mole%	<a href="#">apxNPen</a>
D	12	I-pentane	0.0298	mole%	<a href="#">apxIPen</a>
D	13	Hexane	0.1041	mole%	<a href="#">apxHex</a>
D	14	Heptane	0.0147	mole%	<a href="#">apxHept</a>
D	15	Octane	0.0037	mole%	<a href="#">apxOct</a>
D	16	Nonane	0.0000	mole%	<a href="#">apxNon</a>
D	17	Decane	0.0000	mole%	<a href="#">apxDec</a>
D	18	O2	0.0000	mole%	<a href="#">apxO2</a>
D	19	CO	0.0000	mole%	<a href="#">apxCo</a>
D	20	H2	0.0000	mole%	<a href="#">apxH2</a>
D	21	Neo-pentane	0.0000	mole%	<a href="#">apxNeop</a>
D	22	Ethene	0.0000	mole%	<a href="#">apxEten</a>
D	23	Propene	0.0000	mole%	<a href="#">apxPpen</a>
D	24	Argon	0.0000	mole%	<a href="#">apxArg</a>
B	26	Assessment base	sd,Hs,CO2		<a href="#">approxMod</a>
D	27	rd for assessment	0.584999		<a href="#">d2Approx</a>
D	28	Hs for assessment	1031.42	Btu/ft3	<a href="#">h2Approx</a>

Enter Cancel Load defaults Refresh

**Figure 218: Menu DH Assessed analysis**

Correlative devices for gas analysis offer significantly faster determination of gas parameters in comparison with chromatographic approach. The determination is based on a few gas values (summarized as "gross data") from which a method according to AGA8 of 1985 enables simple determination of a gas analysis. The determination can be erroneous, which means the same gas values can be determined for different gas compositions.

The parameter on the basis of which the calculation of gas values takes place is sought in **DH26**; the following choices are available:

- sd, Hs, CO<sub>2</sub>
- sd, Hs, CO<sub>2</sub>, N<sub>2</sub>
- sd, CO<sub>2</sub>, N<sub>2</sub>
- Hs, CO<sub>2</sub>, N<sub>2</sub>

Where

sd — density at base conditions  
Hs — Calorific value

### 6.4.11 DI Adjustable extra base condition

#### DI Adjustable extra base condition

Access	Line	Designation	Value	Unit	Variable
D	1	Qx(Tx,Px)	0.00	m3/h	Qex
D	2	Xd(Tx,Px)	0.71682	kg/m3	Rex
D	3	Xd/Sd	0.947535		Zex
D	4	Sd/Xd	1.055370		ZexRezi
E *	11	Tx	<input type="text" value="288.150"/>	K	Tex
E *	12	Px	<input type="text" value="0.101325"/>	MPa	Pex

Enter Cancel Load defaults Refresh

Figure 219: Menu DI Adjustable extra base condition

Usually, the base conditions in German-speaking countries are based on 0° C and 1,013.25 mbar. Different bases of standardization in other countries can require different reference values; they can be entered in this menu. As a result, different flow rates and density values at base conditions arise.

This is important for systems at national boundaries. With "different" pressure and temperature reference values to be entered in **DI11** and **DI12**, correct conversion to the various base values can take place.

The variables of flow rate Qb, density at base condition and ratio of two densities at different base conditions, sd (extra base condition) / sd (base condition) are converted with reference to other base conditions. These values are available for assignment to the current outputs.

### 6.4.12 DL Calculations according to GPA 2172-96

#### DL Calculations according GPA 2172-96

Access	Line	Designation	Value	Unit	Variable
D	1	Calorific value	1079.7	Btu/ft3	gpaHo
D	2	Heating value	973.8	Btu/ft3	gpaHu
D	3	Compr.factor	0.9974		gpaCf
D	4	relative density	0.5802		gpaDv

Refresh

Figure 220: Menu DL Calculations according to GPA 2172-96

GPA 2172-96 is an American regulation for calculation of calorific value, heating value, real gas factor and density ratio; it is used instead of ISO6976. This regulation is used in the USA and parts of the far east.

## 6.5 E-Z Additional analysis-specific menus

### 6.5.1 EB Base values

#### EB Base values

Access Line	Designation	Value	Unit	Variable
E *	1	Pbase selection	1.01325 bars	<a href="#">PnWahl</a>
E *	2	Tb selection	0 °C	<a href="#">t_norm</a>
E *	3	Tm selection	25 °C	<a href="#">tb</a>
A *	4	Press.at base cond.	1.01325 bar	<a href="#">pNorm</a>
A *	5	Temp.base Kelvin	273.15 K	<a href="#">TKNorm</a>
A *	6	Temp.base Celsius	0.00 °C	<a href="#">TCNorm</a>
A *	8	Tm factor	1.0000	<a href="#">tb_fakt</a>
A *	9	rd factor	1.0000	<a href="#">dv_fakt</a>
A *	10	Stand.density air	1.292923 kg/m3	<a href="#">Rho_Lu</a>
S	11	CVD constant A	0.0039083 1/°C	<a href="#">calDusA</a>
S	12	CVD constant B	-5.775e-007 °C-2	<a href="#">calDusB</a>
S	13	CVD constant C	-4.183E-012 °C-4	<a href="#">calDusC</a>
W *	14	Gas constant	8.3145100	<a href="#">rqas</a>
W *	15	Mol.vol. ideal gas	22.4140970	<a href="#">vmIdeal</a>
W *	16	Avogadro constant	6.0221415	<a href="#">avogadro</a>
S	17	Device state	Function tested	<a href="#">myState</a>
A *	18	Device family	ERZ 2000-NG	<a href="#">gerSerie</a>
W *	19	Device type	ERZ 2004	<a href="#">gerArt</a>
W *	20	CO2 emission	No	<a href="#">co2zwk</a>
W *	21	Enab. methane no.	OFF	<a href="#">MZRqMod</a>
W *	22	2nd base condition	No	<a href="#">voczwk</a>
B	23	Customers counters	2 sets	<a href="#">kndZwk</a>
E *	24	Mode max. load	PTB	<a href="#">hbiMode</a>

Enter Cancel Load defaults Refresh

Figure 221: Menu EB Base values

In Germany, the base conditions **EB01** and **EB02** for a base volume are based on 1.01325 bar and 0°C. For the European area of application, the base conditions are not uniform with respect to different pressure and temperature values. In the United States, conversions to the units "psi" and "F" apply; in this case, care should be taken to consider that the pressure and temperature values generally deviate from the German base values. In order to avoid conversion errors, the correct values must be used.

As a reference temperature for calorific value Tm selection, the temperature at which the calorific value is determined is normally 25°C in Germany with application of GERG 88 S. However, the temperatures 0°C, 15°C, 20°C and 60°C can also be selected for coordinate **EB03**.

Determination of the gas temperature takes place with the change of a resistance measurement; there are corrections for this because this characteristic curve is not linear. The constants for this linearization of PT100, PT500 and PT1000 temperature transmitters are in coordinates **EB11** to **EB13**.

Coordinate **EB17** shows the production and test status of the device. There are 4 statuses ("brand new", "functionally tested", "pre-tested for official custody transfer" and "commissioned for service"), which can only be reset at the factory.

The inspection authority enters the device type in coordinate **EB19** (see *chapter 1.5.1 Device type adjustment*).

Occasionally, the calculation of a complete base volume meter set is required for a second, different base condition. This must be activated in coordinate **EB22** with "yes". This applies for billing modes (BM) 1, 2, 3 and 4 the main and disturbance totalizer. The calculation is linked to an application of AGA 8 92DC. The corresponding totalizers are in lines 25, 26 and 27 in menus **LB Totalizer, BM1** to **LJ Tot. undef. BM**. The totalizers for the second base conditions are identified in the totalizer overview with Vx1, Vx2, Vx3 and Vx4 for the main totalizers and SVx1, SVx2, SVx3 and SVx4 for the disturbance totalizers.

**Note**

The second base condition is adjusted in menu **DI Adjustable extra base condition**.

For customer totalizer **EB23**, "none", "1 set" and "2 sets" can be selected.

**6.5.2 EF Processing table values**

**EF Processing table values**

Access	Line	Designation	Value	Unit	Variable
D	1	Selected table	1		actTab
T	2	Table selection	Table value 1		tabCtrl

Enter    Cancel    Load defaults    Refresh

**Figure 222: Menu EF Processing table values**

**EF01** shows which gas property table (table value 1, 2, 3 or 4) was selected in **EF02**. The tables contain default values for sd, Hs, CO<sub>2</sub>, H<sub>2</sub>, methane, dv, etc. and are as-

signed in the component menus, e.g. methane in **BE39** to **BE42**. IF "billing mode" is selected, the table value serving as a basis is used.

### 6.5.3 FE Calibration unit standard density / gross calorific value

#### FE Calibration unit standard density/gross calorific value

Access Line	Designation	Value	Unit	Variable
A *	1 Sd connection	Process gas		<a href="#">kTkPrfRn</a>
A *	2 Sd acceptance	OFF		<a href="#">kTkPrfRnSet</a>
E *	3 Source Sd conn.	OFF		<a href="#">kzoPrfRn</a>
E *	4 Source Sd accept.	OFF		<a href="#">kzoPrfRnSet</a>
A *	5 Hs connection	Process gas		<a href="#">kTkPrfHo</a>
A *	6 Hs acceptance	OFF		<a href="#">kTkPrfHoSet</a>
E *	7 Source Hs conn.	OFF		<a href="#">kzoPrfHo</a>
E *	8 Source Hs accept.	OFF		<a href="#">kzoPrfHoSet</a>
T	9 Max. calib. time	180	min	<a href="#">mxKalZeit</a>

Enter Cancel Load defaults Refresh

**Figure 223: Menu FE Calibration unit standard density / gross calorific value**

The calibration of direct measuring density and calorific values meters can be controlled via this menu. This function corresponds to the "old" **FE-06** or the switch set for online calibration calorific value and base density when these measurement variables are delivered by special transmitters (calorimeters with frequency or current output, base density of density transmitters or scales). A special interface for connection of such a reference unit is not available; connection takes place at the contact inputs of the ERZ2000-NG.

## 6.6 Analysis-specific communication

The gas composition, including data calorific value, base density and the individual components can be measured and transmitted in various ways. This transmission was defined in menu **BA Components mode** in coordinates **BA CO2 operating mode** to **BA04 operating mode other components** (see *chapter 6.1.1 BA Components mode*).

301

The data of the gas components is currently still transmitted via analog technology in exceptional cases only; normally, the communication is based on a digital protocol. The Modbus protocol or, more specifically, additionally specified variants, such as EGO Modbus or RMG bus, is used. As a standard in Germany, the technical guideline for the DSfG interface for gas measuring devices has been established under the umbrella of the DVGW.

### 6.6.1 IG Imported gas quality via DSfG

#### IG Imported gas quality via DSfG

Access Line	Designation	Value	Unit	Variable
I	1	Sup.calor.value	11.250 kWh/m3	DSfGhc
I	3	Standard density	0.75651 kg/m3	DSfGrhon
I	4	Relative density	0.5549	DSfGdv
I	6	Carbon dioxide	0.9960 mole%	DSfGco2
I	7	Nitrogen	0.2988 mole%	DSfGn2
I	8	Hydrogen	0.0000 mole%	DSfGh2
I	9	Methane	96.1155 mole%	DSfGmeth
I	10	Helium	0.0000 mole%	DSfGhe
I	11	Hexane+	0.0697 mole%	DSfGhexa
I	12	Propane	0.4482 mole%	DSfGprop
I	13	Propene	0.0000 mole%	DSfGppen
I	14	I-butane	0.0996 mole%	DSfGibut
I	15	N-butane	0.0996 mole%	DSfGnbut
I	16	I-pentane	0.0498 mole%	DSfGipen
I	17	N-pentane	0.0299 mole%	DSfGnpen
I	18	Ethene	0.0000 mole%	DSfGeten
I	19	Ethane	1.7928 mole%	DSfGeth
I	20	Oxygen	0.0000 mole%	DSfGo2
I	21	Carbon monoxide	0.0000 mole%	DSfGco
I	22	Neo-pentane	0.0000 mole%	DSfGneop
I	23	Argon	0.0000 mole%	DSfGarg
I	24	Bit string	0000 hex	bitsDsfg
I	25	Time stamp	DD-MM-YYYY hh:mm:ss	qcStamp
G *	26	Hs unit GQ	<b>kWh/m3</b>	qchoDim
G *	27	sd unit GQ	<b>kg/m3</b>	qcrhonDim
G *	28	Amount of subst.GQ	<b>mole%</b>	qcmolDim
E *	29	Initial. DSFG GQ	Start w/o fault ▾	GCStart
E *	30	GQ1 address	T ▾	adrPqc1
E *	31	DSFG preset GC1	0	psetPqc1
E *	32	GC1 type	Autodetect ▾	typPqc1
E *	33	GQ2 address	OFF ▾	adrPqc2
E *	34	DSFG preset GC2	0	psetPqc2
E *	35	GC2 type	Autodetect ▾	typPqc2
E *	36	GC1 rev.mode	No change ▾	pqc1InRev
E *	37	Query	GERG capable ▾	anfrArt
B	38	Max. waiting time	60	s warteMax
B	39	Max. repetitions	3	retryMax
I	40	Ord.No. analysis	0	onrPqc
I	41	Bit string GC	0000 hex	statPqc
D	43	Cur. analysis of	0	aktAnaPqc
D	44	Next analysis	1	nextAnaPqc
D	45	GC1 condition	Absent	statePqc1
D	46	GC2 condition	Inactive	statePqc2
D	47	Waiting time	0 s	warteZeit
Q	48	GQM1 ignore time	0	min qbh1Ign
Q	49	GQM2 ignore time	0	min qbh2Ign
E *	50	ignoring allowed	For none of GQ's ▾	qbhIgnCtrl
B	51	VNG mode	No ▾	VNGmod

Enter Cancel Load defaults Refresh

Figure 224: Menu IG Imported gas quality via DSfG



Coordinates **IG01** to **IG08** display the measurement values as they were received via DSfG. The original input value is shown here: i.e. when the PGC is in revision, the measurement of the test gas is shown here. This value does not become the measurement until after various plausibility checks and filtering and is then used in the ERZ2004-NG for further conversion. If the original measurement value is not contained in the DSfG telegram, it is identified as an "illogical" value set to "-1" and thus marked as not provided.

303

The complete gas analysis in coordinates **IG09** to **IG23** is only available by means of an AGA8-compatible standard query (see **IG37 Query**). If the component is not included in the answer to the standard query, the physically illogical value appears as "-1". The AGA8-compatible query contains no relative density. Therefore, the relative density must be calculated in the computer itself.

**IG37 Query** defines the data content for the DSfG query to the gas composition measuring device. The AGA8-compatible query also transmits the full analysis, in addition to the basic quality values. The GERG-compatible query is only used if the gas composition measurement does not support the AGA8-compatible query (old devices) or the measuring principle of the gas composition measurement does not provide a (adequate) full analysis (correlative method).

#### Note

**The AGA8-compatible query contains no relative density. Therefore, they must be calculated in the converter.**

For this purpose, the operating mode is parameterized for relative density for determination from base density. The AGA8-compatible query enables all status coefficient calculations. The GERG-compatible query is only used if the gas composition measurement does not support the AGA8-compatible query (old devices) or the measuring principle of the gas composition measurement does not provide a (adequate) full analysis (correlative method).

With the "Start with fault" setting in coordinate **IG29 Initial. DsfG GQ**, an alarm is generated during the calibration phase after "NETWORK ON". It disappears as soon as valid gas composition data is available.

The DSfG address of the leading DSfG transmitter for gas composition is provided in coordinate **IG30 GQ1 address**. Coordinate **IG32 GC1 type** can be set to "auto-detect", "G entity" or "Q entity".

If a second (redundant) PGC is used, the DSfG address of the redundant DSfG transmitter must be entered in coordinate **IG33 GQ2 address**.

Coordinate **IG36 GC1 revision mode** defines whether, in case of an revision, (calibration or ref. gas) to remain on the leading gas composition measuring device or to switch to the redundant gas composition measuring device.

The maximum wait time for "usable" gas composition data is specified in coordinate **IG38 Max. wait time**. For this purpose, this query can be restarted several times – in coordinate **IG39 Max. repetitions**.

Coordinate **IG43 Current analysis of** specifies whether the leading or the redundant gas composition transmitter is used for the current conversion.

If coordinate **IG50 GQM1 ignore time** is set to "for none GQ's", it means that the analysis end messages are considered and/or edited (normal case). If the setting is "only for GC1", analysis end messages from GC1 are ignored (analogous for "only for GC1"). With "for both GCs", the analysis end messages of GC1 and GC2 is ignored.

Coordinates **IG 48 GC1 Ignore time** and **IG 49 GC2 Ignore time** can be used to parameterize how long it should be ignored in each case for each gas composition measuring device.

For VNG applications, in particular, coordinate **IG51 VGN mode** is used to adjust that PGC alarms in the computer have no additional effect.

### Note

It is possible to assign 2 gas composition measuring devices (e.g. 2 PGCs) on the DSfG bus redundantly to the ERZ2000-NG. If both PGCs are running without disturbance, the ERZ2000-NG always uses the main PGC according to the DSfG rules. In case of a malfunction of the main PGC (evaluation of the bit string), the ERZ2000-NG uses the measurements of the redundant PGC until the main PGC works again without disturbances. With the changeover to the redundant measuring device, the ERZ2000-NG can also adapt the computing process for the K coefficient calculation.

### Example:

The main PGC provides a full analysis and the ERZ2000-NG computes with the AGA 8 92 DC. The comparison measuring device (e.g. correlative) provides only calorific value, standard density and CO<sub>2</sub>. With the changeover to the comparison device, the ERZ2000-NG switches the computation process from AGA 8 92 DC to GERG 88S automatically. The parameters for the ERZ2000-NG are specified under coordinates **IG Import gas quality via DSfG**.

6.6.2 IJ Imp. GC Modbus main

IJ Imported main gas quality via modbus

Access Line	Designation	Value	Unit	Variable
M	1	Trigger Werne	0	mb_dummy
M	2	Bit string	0	mb_dei
M	3	Calorific value	11.250 kWh/m3	mb_ho
M	4	Relative density	0.5549	mb_dy
M	5	standard density	0.75651 kg/m3	mb_rhoa
M	6	CO2	0.9960 mole%	mb_co2
M	7	H2	0.0000 mole%	mb_h2
M	8	N2	0.2988 mole%	mb_n2
M	9	Methane	96.1155 mole%	mb_meth
M	10	Ethane	1.7928 mole%	mb_eth
M	11	Propane	0.4482 mole%	mb_prop
M	12	N-butane	0.0996 mole%	mb_nbut
M	13	I-butane	0.0996 mole%	mb_ibut
M	14	N-pentane	0.0299 mole%	mb_npen
M	15	I-pentane	0.0498 mole%	mb_igen
M	16	Neo-pentane	0.0000 mole%	mb_neop
M	17	Hexane	0.0697 mole%	mb_hexa
M	18	Heptane	0.0000 mole%	mb_hept
M	19	Octane	0.0000 mole%	mb_oct
M	20	Nonane	0.0000 mole%	mb_non
M	21	Decane	0.0000 mole%	mb_dec
M	22	H2S	0.0000 mole%	mb_h2s
M	23	H2O	0.0000 mole%	mb_h2o
M	24	Helium	0.0000 mole%	mb_he
M	25	O2	0.0000 mole%	mb_o2
M	26	CO	0.0000 mole%	mb_co
M	27	Ethene	0.0000 mole%	mb_eten
M	28	Propene	0.0000 mole%	mb_ppen
M	29	Argon	0.0000 mole%	mb_arg
M	30	Id. GQ-source	0	mb_idqll
M	31	main/backup	0	mb_prio
M	32	GQ type	0	mb_gbht
M	33	Ord.No Analysis	0	mb_ord
M	34	time stamp	19-09-2018 10:50:43	mb_time
M	35	CRC12 protection	0	mb_crc12
M	36	roadway	0	mb_fw
M	37	protected list	0	mb_idUst
G *	38	Hs unit GC	kWh/m3	mbhoDim
G *	39	sd unit GC	kg/m3	mbrhenDim
G *	40	Amount of subst.GC	mole%	mbmolDim
E *	41	Initial. MODB-GC	Start w/o fault	MBStart
A *	42	better GQ	Main GQ	mbHBQ
A *	43	Actual value CRC12	0	mb_cst
E *	44	1. allowed GQ-Id	0	whid1
E *	45	Preset for GQ-Id 1	0	whpsst1
E *	46	2. allowed GQ-Id	0	whid2
E *	47	Preset for GQ-Id 2	0	whpsst2
E *	48	3. allowed GQ-Id	0	whid3
E *	49	Preset for GQ-Id 3	0	whpsst3
E *	50	4. allowed GQ-Id	0	whid4
E *	51	Preset for GQ-Id 4	0	whpsst4
E *	52	use GQM	No	wgma
E *	53	Nominal v. GQM list	0	plldiList
B	54	Mx.time revision	3600 s	GbhRevMx
D	55	Main-GQ rating	Uncertain	hgbbQ
D	56	time since entry	0 s	HGbbTo
D	58	Time since Revis.	0 s	HGbbRev
B	59	GQM uncompl. Msg.	Show	werneMsg
M	60	state of pipe closed	0	mb_pipeZu
M	61	Reserve GQM-Main	0	mb_resv01
M	62	Reserve GQM-Main	0	mb_resv02
M	63	Reserve GQM-Main	0	mb_resv03
M	64	Reserve GQM-Main	0	mb_resv04
M	65	Reserve GQM-Main	0	mb_resv05
M	66	Reserve GQM-Main	0	mb_resv06
M	67	Reserve GQM-Main	0	mb_resv07
M	68	Reserve GQM-Main	0	mb_resv08
M	69	Reserve GQM-Main	0	mb_resv09
M	70	Reserve GQM-Main	0	mb_resv10
M	71	Reserve GQM-Main	0	mb_resv11
M	72	Reserve GQM-Main	0	mb_resv12
M	73	Reserve GQM-Main	0	mb_resv13
M	74	Reserve GQM-Main	0	mb_resv14
M	75	Reserve GQM-Main	0	mb_resv15

Figure 225: Menu IJ Import GC Modbus main measurement

### 6.6.3 IK Imp. GC Modbus ref

**IK Imported backup gas quality via modbus**

Access Line	Designation	Value	Unit	Variable
M	1	Trigger Weme	0	mbbdummy
M	2	Bit string	6153	mbbdei
M	3	Calorific value	11.250 kWh/m3	mbbho
M	4	Relative density	0.5549	mbbdv
M	5	standard density	0.75651 kg/m3	mbbrhon
M	6	CO2	0.9960 mole%	mbbco2
M	7	H2	0.0000 mole%	mbbh2
M	8	N2	0.2988 mole%	mbbn2
M	9	Methane	96.1155 mole%	mbbmeth
M	10	Ethane	1.7928 mole%	mbbeth
M	11	Propane	0.4482 mole%	mbbprop
M	12	N-butane	0.0996 mole%	mbbnbut
M	13	I-butane	0.0996 mole%	mbbibut
M	14	N-pentane	0.0299 mole%	mbbnpen
M	15	I-pentane	0.0498 mole%	mbbipen
M	16	Neo-pentane	0.0000 mole%	mbbneop
M	17	Hexane	0.0697 mole%	mbbhexa
M	18	Heptane	0.0000 mole%	mbbhept
M	19	Octane	0.0000 mole%	mbboct
M	20	Nonane	0.0000 mole%	mbbnon
M	21	Decane	0.0000 mole%	mbbdec
M	22	H2S	0.0000 mole%	mbbh2s
M	23	H2O	0.0000 mole%	mbbh2o
M	24	Helium	0.0000 mole%	mbbhe
M	25	O2	0.0000 mole%	mbbo2
M	26	CO	0.0000 mole%	mbbco
M	27	Ethene	0.0000 mole%	mbbeten
M	28	Propene	0.0000 mole%	mbbpen
M	29	Argon	0.0000 mole%	mbbarq
M	30	Id. GQ-source	0	mbbidQll
M	31	main/backup	0	mbbprio
M	32	GQ type	0	mbbqbht
M	33	Ord.No. Analysis	0	mbbord
M	34	time stamp	19-09-2018 10:50:43	mbbtime
M	35	CRC12 protection	0	mbbccrc12
M	36	roadway	0	mbbfw
M	37	protected list	0	mbbidList
A *	43	Actual value CRC12	0	mbbcist
E *	44	1. allowed GQ-Id	<input type="text" value="0"/>	wvid1
E *	45	Preset for GQ-Id 1	<input type="text" value="0"/>	wvpset1
E *	46	2. allowed GQ-Id	<input type="text" value="0"/>	wvid2
E *	47	Preset for GQ-Id 2	<input type="text" value="0"/>	wvpset2
E *	48	3. allowed GQ-Id	<input type="text" value="0"/>	wvid3
E *	49	Preset for GQ-Id 3	<input type="text" value="0"/>	wvpset3
E *	50	4. allowed GQ-Id	<input type="text" value="0"/>	wvid4
E *	51	Preset for GQ-Id 4	<input type="text" value="0"/>	wvpset4
D	55	Back-GQ rating	Uncertain	vabhQ
D	56	time since entry	0 s	VGbhTo
D	58	Time since Revis.	0 s	VGbhRev
M	60	state of pipe closed	0	mbbpipeZu
M	61	Reserve GQM-Ref	0	mbbresv01
M	62	Reserve GQM-Ref	0	mbbresv02
M	63	Reserve GQM-Ref	0	mbbresv03
M	64	Reserve GQM-Ref	0	mbbresv04
M	65	Reserve GQM-Ref	0	mbbresv05
M	66	Reserve GQM-Ref	0	mbbresv06
M	67	Reserve GQM-Ref	0	mbbresv07
M	68	Reserve GQM-Ref	0	mbbresv08
M	69	Reserve GQM-Ref	0	mbbresv09
M	70	Reserve GQM-Ref	0	mbbresv10
M	71	Reserve GQM-Ref	0	mbbresv11
M	72	Reserve GQM-Ref	0	mbbresv12
M	73	Reserve GQM-Ref	0	mbbresv13
M	74	Reserve GQM-Ref	0	mbbresv14
M	75	Reserve GQM-Ref	0	mbbresv15

Figure 226: Menu IK Import GC Modbus reference measurement

The menus **IJ Import GC Modbus main measurement** and **IK Import GC Modbus reference measurement** treat a special case of the data import via Modbus (Modbus IP), which, for example, was implemented in the gas transfer station. In the process, gas composition data of the main PGC in menu **IJ** and the data of the comparison PGC (reference) is provided in menu **IK**.

### 6.6.4 IL Modbus Master GC1

#### IL Modbus Master GC1

Access	Line	Designation	Value	Unit	Variable
E *	1	Sup.calorific val.	F7020	kWh/m3	exp1Ho
E *	2	Stand.density	F7024	kg/m3	exp1Rn
E *	3	Carbon dioxide	F8254	mole%	exp1CO2
E *	4	Hydrogen	F8284	mole%	exp1H2
E *	5	Nitrogen	F8250	mole%	exp1N2
E *	6	Methane	F8252	mole%	exp1Meth
E *	7	Ethane	F8256	mole%	exp1Eth
E *	8	Propane	F8258	mole%	exp1Prop
E *	9	N-butane	F8262	mole%	exp1NBut
E *	10	I-butane	F8260	mole%	exp1IBut
E *	11	N-pentane	F8268	mole%	exp1NPen
E *	12	I-pentane	F8266	mole%	exp1IPen
E *	13	Neo-pentane	F8264	mole%	exp1Neop
E *	14	Hexane/C6+	F8272	mole%	exp1Hexa
E *	15	Heptane/C7+	F8274	mole%	exp1Hept
E *	16	Octane/C8+	F8276	mole%	exp1Oct
E *	17	Nonane/C9+	F8278	mole%	exp1Non
E *	18	Decane/C10+	0	mole%	exp1Dec
E *	19	Hydrogen sulphide	0	mole%	exp1H2S
E *	20	Water	0	mole%	exp1H2O
E *	21	Helium	F8282	mole%	exp1He
E *	22	Oxygen	F8280	mole%	exp1O2
E *	23	Carbon monoxide	0	mole%	exp1CO
E *	24	Ethene	0	mole%	exp1Eten
E *	25	Propene	0	mole%	exp1Ppen
E *	26	Argon	F8286	mole%	exp1Arg
E *	27	Status	u1038==0		exp1Stat
D	30	Time stamp	DD-MM-YYYY hh:mm:ss		mb1_stamp
D	31	Analyze counter	0		mb1AnaCnt
D	32	Communication	waiting		mb1_ok
D	33	Data timeout	359348 s		mb1_datato
D	34	Sum components	0.0000 mole%		mb1KmpSum
D	35	Exception code	0		mb1ExcCod
D	36	Exception counter	0		mb1ExcCnt
E *	50	Operating mode	Modbus-serial C6		mb1_ifac

E *	50	Operating mode	Modbus-serial C6		mb1_ifac
E *	51	IP-Address	192.168.20.143		mb1_ipAdr
E *	52	Modbus address	1		mb1_Adr
E *	53	ModbusIP timeout	2000	ms	mb1timo
E *	54	Slave accepts gaps	No		mb1_loecher
E *	55	Byteorder 16Bit Int	21		mb1_bo_u
E *	56	Byteorder 32Bit Int	4321		mb1_bo_U
E *	57	Byteorder float	4321		mb1_bo_F
E *	58	Byteorder double	21436587		mb1_bo_D
E *	59	Read function code	4		mb1_fc
E *	60	Register	16 bit oriented		mb1_enron
A *	70	actual selected	univ.Modb.Master 1		selUmbm
A *	71	Position contact	OFF		ktkUmbm
E *	72	Selection mode	Always Master 1		modUmbm
E *	73	selected contact	OFF		kzoUmbm
B	80	Value 1	0		exp1Diag1
B	81	Value 2	0		exp1Diag2
B	82	Value 3	0		exp1Diag3
B	83	Value 4	0		exp1Diag4
B	84	Value 5	0		exp1Diag5
B	85	Value 6	0		exp1Diag6
B	86	Value 7	0		exp1Diag7
B	87	Value 8	0		exp1Diag8
B	88	Value 9	0		exp1Diag9
B	89	Value 10	0		exp1Diag10
B	98	used button	GQS400		exp1btn

Figure 227: Menu IL Modbus Master GC1

With this coordinate, the ERZ input variables are linked with the desired PGC data or with the data of a GQS400.

Gas chromatograph PGC9300 of RMG offers the possibility of operating 4 different measuring points; in the process, the measuring point is switched after each measurement. These measuring points are identified as Stream 1, Stream 2, Stream 3 and Stream 4. If one of the buttons under the table (PGC9300: Stream 1, 2, 3 or 4) is activated, the assigned measurement point is operated (only). A presetting takes place (the affected fields have a bright

yellow-green background) and the measured values are assigned Modbus addresses. If a different stream is selected, the Modbus address assignment changes. In menu **IM Modbus Master GC2**, a different stream can be selected for the same PGC. Therefore, 2 different measuring points can be operated.

If a GQS400 is evaluated here, the Modbus addresses must be set accordingly. Further details can be found in the manual of the GQS400.

The applicable computation possibilities described in *chapter 3.3.2 Modbus master overview* enable the conversions described below:

### Unit conversion

A value coming from the PGC can be converted using a conversion factor. For instance, to convert the calorific value with the unit **kWh/m<sup>3</sup>** to **MJ/m<sup>3</sup>**, "F7020\*3.6" must be entered in coordinate **IL01**.

E §	1	Sup.calorific val.	F7020*3.6	MJ/m <sup>3</sup>
-----	---	--------------------	-----------	-------------------

### Addition rules

It is possible that there is no entry field available in the ERZ2000-NG for a gas component measured by the PGC, such as cyclo-pentane in register 8290. In this case, the cyclo-pentane can be added to the share of another component, e.g. neo-pentane in register 8264. Then, "F8264+F8290" must be entered in coordinate **IL13**.

E §	13	Neo-pentane	F8264+F8290	mol-%
-----	----	-------------	-------------	-------

### Distribution rules

It is possible that a PGC does not output the components hexane, heptane, octane, nonane and decane individually, rather as the sum of hexane plus higher alkanes, generally in register F8272. In this case, the sum is distributed according to the 1/3 rule of the respective components: hexane, heptane, octane, ... provided in the ratio of 81 : 27 : 9 : 3 : 1. Standardized to 121 (= 81 + 27 + 9 + 3 + 1) produces the ratios 81/121 : 27/121 : 9/121 : 3/121 : 1/121. Then, the following must be entered in **IL14** to **IL18**:

E §	14	Hexane/C6+	(81/121)*F8272	mol-%
E §	15	Heptane/C7+	(27/121)*F8272	mol-%
E §	16	Octane/C8+	(9/121)*F8272	mol-%
E §	17	Nonane/C9+	(3/121)*F8272	mol-%
E §	18	Decane/C10+	(1/121)*F8272	mol-%

### Constants

It is possible that components which are provided to the ERZ2000-NG by the PGC are not predetermined and available, such as hydrogen sulphide, water, carbon monoxide, ethene and propene. Therefore, they are zeroed as follows:

E §	19	Hydrogen sulphide	0	mol-%
E §	20	Water	0	mol-%
E §	23	Carbon monoxide	0	mol-%
E §	24	Ethene	0	mol-%
E §	25	Propene	0	mol-%

---

 309
 

---

Information relating to coordinates **IL27** to **IL73** is provided as Modbus-specific commands, which are listed in *chapter 3.3.2 Modbus master overview*.

In the coordinates **IL80** to **IL89** different measurement or diagnostic values can be assigned, e.g. calorific value or similar.

Coordinate **IL98 used button** indicates which button was activated, e.g. "PGC9300: Stream 1".

### 6.6.5 IM Modbus Master GC2

#### IM Modbus Master GC2

Access Line	Designation	Value	Unit	Variable
E *	1	Sup.calorific val.	F7020	kWh/m3 <a href="#">exp2Ho</a>
E *	2	Stand.density	F7024	kg/m3 <a href="#">exp2Rn</a>
E *	3	Carbon dioxide	F8254	mole% <a href="#">exp2CO2</a>
E *	4	Hydrogen	F8284	mole% <a href="#">exp2H2</a>
E *	5	Nitrogen	F8250	mole% <a href="#">exp2N2</a>
E *	6	Methane	F8252	mole% <a href="#">exp2Meth</a>
E *	7	Ethane	F8256	mole% <a href="#">exp2Eth</a>
E *	8	Propane	F8258	mole% <a href="#">exp2Prop</a>
E *	9	N-butane	F8262	mole% <a href="#">exp2NBut</a>
E *	10	I-butane	F8260	mole% <a href="#">exp2IBut</a>
E *	11	N-pentane	F8268	mole% <a href="#">exp2NPen</a>
E *	12	I-pentane	F8266	mole% <a href="#">exp2IPen</a>
E *	13	Neo-pentane	F8264	mole% <a href="#">exp2Neop</a>
E *	14	Hexane/C6+	F8272	mole% <a href="#">exp2Hexa</a>
E *	15	Heptane/C7+	F8274	mole% <a href="#">exp2Hept</a>
E *	16	Octane/C8+	F8276	mole% <a href="#">exp2Oct</a>
E *	17	Nonane/C9+	F8278	mole% <a href="#">exp2Non</a>
E *	18	Decane/C10+	0	mole% <a href="#">exp2Dec</a>
E *	19	Hydrogen sulphide	0	mole% <a href="#">exp2H2S</a>
E *	20	Water	0	mole% <a href="#">exp2H2O</a>
E *	21	Helium	F8282	mole% <a href="#">exp2He</a>
E *	22	Oxygen	F8280	mole% <a href="#">exp2O2</a>
E *	23	Carbon monoxide	0	mole% <a href="#">exp2CO</a>
E *	24	Ethene	0	mole% <a href="#">exp2Eten</a>
E *	25	Propene	0	mole% <a href="#">exp2Ppen</a>
E *	26	Argon	F8286	mole% <a href="#">exp2Arg</a>
E *	27	Status	u1038==0	<a href="#">exp2Stat</a>
B	28	Diagnosis 1	0	<a href="#">exp2Diag1</a>
B	29	Diagnosis 2	0	<a href="#">exp2Diag2</a>
D	30	Time stamp	DD-MM-YYYY hh:mm:ss	<a href="#">mb2_stamp</a>
D	31	Analyze counter	0	<a href="#">mb2AnaCnt</a>
D	32	Communication	waiting	<a href="#">mb2_ok</a>
D	33	Data timeout	3601 s	<a href="#">mb2_datato</a>
D	34	Sum components	0.0000	mole% <a href="#">mb2KmpSum</a>
D	35	Exception code	0	<a href="#">mb2ExcCod</a>
D	36	Exception counter	0	<a href="#">mb2ExcCnt</a>
E *	50	Operating mode	OFF	<a href="#">mb2_ifac</a>
E *	51	IP-Address	192.168.20.144	<a href="#">mb2_ipAdr</a>
E *	52	Modbus address	1	<a href="#">mb2_Adr</a>
E *	53	ModbusIP timeout	2000	ms <a href="#">mb2time</a>
E *	54	Slave accepts gaps	No	<a href="#">mb2_loecher</a>
E *	55	Byteorder 16Bit Int	21	<a href="#">mb2_bo_u</a>
E *	56	Byteorder 32Bit Int	2143	<a href="#">mb2_bo_U</a>
E *	57	Byteorder float	2143	<a href="#">mb2_bo_F</a>
E *	58	Byteorder double	21436587	<a href="#">mb2_bo_D</a>
E *	59	Read function code	3	<a href="#">mb2_fc</a>
B	98	used button	?	<a href="#">exp2btn</a>

PGC9300: Stream 1
PGC9300: Stream 2
PGC9300: Stream 3
PGC9300: Stream 4

Figure 228: Menu IM Modbus Master GC2

Menu IM Modbus Master GC2 has the same layout as menu IL Modbus Master GC 1 (without lines 70 to 73).



### 6.6.6 IH Imported gas quality via RMG bus

IH Imported gas quality via RMG bus

Access Line	Designation	Value	Unit	Variable
A *	2 Interpretation	<b>Substitute value</b>		rmgTyp
A *	3 Sup. calor. value	<b>11.250</b>	kWh/m3	rmgtho
A *	4 Standard density	<b>0.75651</b>	kg/m3	rmgrhon
A *	5 Relative density	<b>0.5549</b>		rmgbdv
A *	6 Methane	<b>96.1155</b>	mole%	rmgmeth
A *	7 Ethan	<b>1.7928</b>	mole%	rmgbeth
A *	8 Propane	<b>0.4482</b>	mole%	rmgprop
A *	9 I-butane	<b>0.0996</b>	mole%	rmgibut
A *	10 N-butane	<b>0.0996</b>	mole%	rmgnbut
A *	11 I-pentane	<b>0.0498</b>	mole%	rmgipecn
A *	12 N-pentane	<b>0.0299</b>	mole%	rmgnpecn
A *	13 Neo-pentane	<b>0.0000</b>	mole%	rmgncpcc
A *	14 Hexane+	<b>0.0697</b>	mole%	rmgthexa
A *	15 Carbon dioxide	<b>0.9960</b>	mole%	rmgcco2
A *	16 Nitrogen	<b>0.2988</b>	mole%	rmgnn2
A *	17 Heptane	<b>0.0000</b>	mole%	rmgthep7
A *	18 Octane	<b>0.0000</b>	mole%	rmgboct
A *	19 Nonane	<b>0.0000</b>	mole%	rmgnnon
A *	20 Decane	<b>0.0000</b>	mole%	rmgbdcc
A *	21 Oxygen	<b>0.0000</b>	mole%	rmgbo2
A *	22 Helium	<b>0.0000</b>	mole%	rmgthhe
A *	23 Hydrogen	<b>0.0000</b>	mole%	rmgbb2
A *	24 Argon	<b>0.0000</b>	mole%	rmgbarq
A *	25 Hydrogen sulphide	<b>0.0000</b>	mole%	rmgbb2s
A *	26 Water	<b>0.0000</b>	mole%	rmgbb2o
A *	27 Carbon monoxide	<b>0.0000</b>	mole%	rmgcco
A *	28 Ethene	<b>0.0000</b>	mole%	rmgbeten
A *	29 Propene	<b>0.0000</b>	mole%	rmgpropen
A *	37 Current status	<b>Okay</b>		rmgErr
A *	38 Time stamp	<b>DD-MM-YYYY hh:mm:ss</b>		rmgStamp
A *	39 Counter of analyzes	<b>0</b>		rmgAnaCnt
G *	40 Hs unit GC	<b>kWh/m3</b>		rhhoDim
G *	41 sd unit GC	<b>kg/m3</b>		rhonDim
G *	42 Amount of subst.GC	<b>mole%</b>		rbmlDim
E *	43 Stream selection	Without indication		RStream
E *	44 Initial. RMGB GC	Start w/o fault		RStart
B	45 RMG bus monitoring	80	s	RBTgCtrl
I	46 Current stream	0		rmgoStream
I	47 Current state	Invalid		rmgoStat
I	48 Current status	Okay		rmgoErr
I	50 GC tg: Hs	0.000	kWh/m3	rmgoho
I	51 GC tg: sd	0.00000	kg/m3	rmgorhon
I	52 GC tg: rd	0.0000		rmgodv
I	53 GC tg: C1	0.0000	mole%	rmgometh
I	54 GC tg: C2	0.0000	mole%	rmgoeth
I	55 GC tg: C3	0.0000	mole%	rmgoprop
I	56 GC tg: I-C4	0.0000	mole%	rmgoibut
I	57 GC tg: N-C4	0.0000	mole%	rmgonbut
I	58 GC tg: I-C5	0.0000	mole%	rmgoipen
I	59 GC tg: N-C5	0.0000	mole%	rmgonpen
I	60 GC tg: Neo-C5	0.0000	mole%	rmgoneop
I	61 GC tg: C6+	0.0000	mole%	rmgohexa
I	62 GC tg: CO2	0.0000	mole%	rmgoco2
I	63 GC tg: N2	0.0000	mole%	rmgonn2
I	64 24K tg: C6	0.0000	mole%	rmgonhex
I	65 24K tg: C7	0.0000	mole%	rmgohept
I	66 24K tg: C8	0.0000	mole%	rmgooct
I	67 24K tg: C9	0.0000	mole%	rmgonon
I	68 24K tg: C10	0.0000	mole%	rmgodec
I	69 24K tg: O2	0.0000	mole%	rmgoo2
I	70 24K tg: He	0.0000	mole%	rmgohe
I	71 24K tg: H2	0.0000	mole%	rmgob2
I	72 24K tg: Ar	0.0000	mole%	rmgoarq
I	73 24K tg: H2S	0.0000	mole%	rmgob2s
I	74 24K tg: H2O	0.0000	mole%	rmgob2o
I	75 24K tg: CO	0.0000	mole%	rmgoco
I	76 24K tg: C2H4	0.0000	mole%	rmgoeten
I	77 24K tg: C3H6	0.0000	mole%	rmgoopen
D	78 Time stamp	0 s		rmgoStamp
D	79 Counter of teleg.	0		rmgoTgCnt

Figure 229: Menu IH Imported gas quality via RMG bus

Possible characteristics of the utility values are a substitute value (of the converter), a living value (of the GC) or as a hold value (of the GC). Fields **IH03** to **IH29** show the assignable gas composition data. In order to use them for the conversion, "RMG bus" operating mode must be parameterized for the appropriate measurement inputs. The assignment of the computer to a stream (1...4) takes place in **IH43 Stream selection** (The PGC of RMG enables up to 4 measuring points). The setting "without reference" means no stream assignment. The setting "Start with error" in coordinate **IH44 Initial. RMGB GC** after NETWORK ON generates an alarm during the calibration phase. It disappears as soon as valid gas composition data is available.

Fields **IH50** to **IH77** show the original gas composition data originating directly from the PGC. They are used in combination with the stream selection and adopted to the values **IH03** to **IH29** if applicable. The original data can also be forwarded to other computers via a COM interface with the operating mode "RMG Bus output".

### Note

**With display of the gas composition data, slight deviations from the original values of the PGC can arise due to the format definitions.**

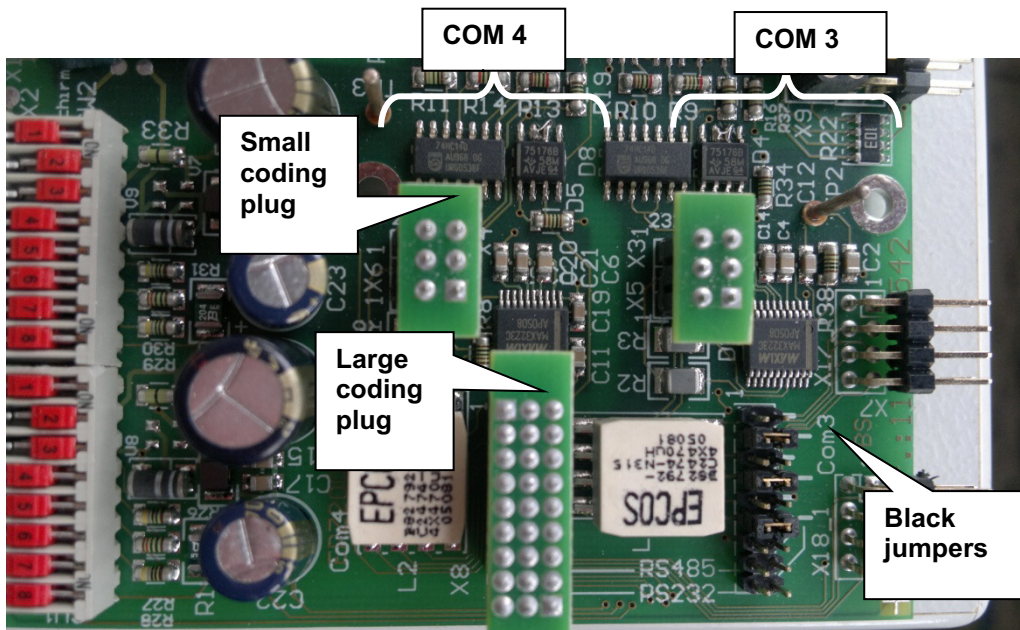
### Overview

- The RMG bus transmits the gas analysis data of a PGC (e.g. GC 9000, GC 9300) to one or multiple computers (e.g. ERZ2000, ERZ2000-NG).
- The PGC master sends a write request telegram as a broadcast every 30 seconds to all computer slaves on the bus.
- The data field of the telegram contains gas analysis data, the stream number and status information.
- The bus operates as RS-485. The wiring takes place in the same manner as for the DSfG bus.
- COM 4 is provided as an interface for the ERZ2000-NG. The plug assignment of COM 4 is described in *chapter 2.7 Electrical connections*.

### COM 4 is configured as RS-485

- COM 4 is implemented on the COM3/COM4 board.
- It is configured with coding plugs or jumpers as RS-485 or RS-232.
- The positioning variants of the plug elements are printed on the circuit boards.
- The bus termination takes place with the DIL switches (see *Figure 105: DIL switches of COM 3 and COM 4* and *Figure 230: Coding plugs and bridges of COM 3 and COM 4*).

**Coding plugs / jumpers:**



**Figure 230: Coding plugs and bridges of COM 3 and COM 4**

**Parameterize COM 4**

**IB Serial interfaces**

Access Line		Name	Value	Unit
B	10	COM4 Baud rate	9600	
B	11	COM4 B/P/S	8E1	
B	12	COM4 Operating mode	RMG-Bus	

Selection of values in the white fields

**Checking of bus activity**

In order to check the bus activity, the values of the PGC are compared with those in the menu **IH Imported gas composition via RMG bus** (see *Figure 229: Menu IH*). The imported gas composition values (e.g. **IH02** bis **IH39**) must match the original values of the PGC.

**Re-using imported gas composition values**

Examples for calorific value, standard density and components:

314

**AD Calorific value**

A § 1	Measurement variable	11.350	kWh/m3
A § 2	Input value -> <a href="#">IH03</a>	11.350	kWh/m3
E § 3	Operating mode	RMG-Bus	

**AE Standard density**

A § 1	Measurement variable	0.77068	kg/m3
A § 2	Input value -> <a href="#">IH04</a>	0.77068	kg/m3
E § 3	Operating mode	RMG-Bus	

**BA Component mode**

Access Line	Name	Value	Unit
E § 1	CO2 operating mode	RMG-Bus	
E § 2	H2 operating mode	Vorgabe	
E § 3	N2 operating mode	RMG-Bus	
E § 4	Change operating mode	RMG-Bus	

**Timeout monitoring**

**Option 1: Monitoring with coordinate [IH45](#) RMG bus control**

B 45	RMG bus monitoring	60	s
------	--------------------	----	---

Pull out the bus plug for the test. 60 seconds after the last received RMG bus telegram, the notice comes (no warning, no alarm):

+ H64-0 RMG bus missing Connection to RMG bus interrupted

If the bus plug is re-inserted, the notice goes with the next bus telegram.

**Option 2: Monitoring with coordinate [IB16](#) timeout gas quality**

Access Line	Name	Value	Unit
T 16	Timeout gas quality	5	min

This timeout monitor only intercedes when at least one RMG bus value is re-used, e.g. the calorific value defined in coordinate AD 03 Calorific value operating mode. Pull out the bus plug for the test. The alarm comes after about 5 minutes:

+ A96-7 Hs GC timeout Calorific value sensor communication error

and the calorific value switches to the default value. If the bus plug is re-inserted, the alarm goes with the next bus telegram and the calorific value shows the current RMG bus value.

315

**Processing 24 Components**

Newer gas analysis devices, such as the GC 9300, deliver significantly more analysis data than, for example, the older GC 9000. In order to import up to 24 gas components in the ERZ2000-NG via RMG bus, the appropriate operating mode must be parameterized on COM 4.

IB Serial interfaces

Access Line	Name	Value	Unit
B	12 COM4 Operating mode	RMG-Bus-24K	

**Note**

For re-use of the imported data, e.g. in the calorific value input, RMG bus must be the setting for the operating mode. There is no special 24K parameterization for the measurement inputs.

AD Calorific value

A § 1	Measurement variable	11.350	kWh/m3
A § 2	Input value -> <a href="#">IH03</a>	11.350	kWh/m3
E § 3	Operating mode	RMG-Bus	

## 6.6.7 IP Modbus EGO Erdgas Ostschweiz

### IP Modbus EGO Erdgas Ostschweiz

Access	Line	Designation	Value	Unit	Variable
I	1	Counter Vb	76810	*100 m3	<a href="#">egoVn</a>
I	2	Counter Vm	111118	m3	<a href="#">egoVb</a>
I	3	Counter energy	81792	MWh	<a href="#">egoE</a>
I	4	Disturbcnt. Vb	4689	*100 m3	<a href="#">egoSVn</a>
I	5	Disturbcnt. Vm	7195	m3	<a href="#">egoSVb</a>
I	6	Disturbcnt. energy	5042	MWh	<a href="#">egoSE</a>
I	7	Flow Qb	0.00	m3/h	<a href="#">egoQn</a>
I	8	Flow Qm	0.000	m3/h	<a href="#">egoQb</a>
I	9	Flow Qe	0.0	kW	<a href="#">egoQe</a>
M	10	Standard density	0.7565	kg/m3	<a href="#">egoRhon</a>
M	11	Gross cal.val.	11.250	kWh/m3	<a href="#">egoHo</a>
M	12	Hydrogen	1.000	mole%	<a href="#">egoH2</a>
M	13	Carbon dioxide	0.996	mole%	<a href="#">egoCo2</a>
I	14	Oper. density	35.000	kg/m3	<a href="#">egoRhob</a>
I	15	Abs. pressure	5.500	bar	<a href="#">egoDrka</a>
I	16	Temperature	20.00	°C	<a href="#">egoTemp</a>
I	17	Alarm	0		<a href="#">egoStat</a>

**Figure 231: Menu IP Modbus EGO Erdgas Ostschweiz**

This is a special interface for *Erdgas Ostschweiz*. The calorific value is written via EGO Modbus master to the ERZ2000-NG.

### Note

**EGO mode only works advantageously with GERG 88.**

- Standard density, calorific value, hydrogen and carbon monoxide can be described via Modbus. In order to ensure that the values are used for conversion, the operating mode of the corresponding measurement input must be parameterized to *EGO Modbus*.
- There is no special EGO interface operating mode.
- EGO mode does not work with billing modes 2, 3, 4
- EGO mode does not work with 14-digit totalizers.
- EGO mode defines fixed values in advance. (m3, kWh, m3/h, kW, kg/m3, mol.%, bar, degrees Cel.).

EGO-specific Modbus registers are:

Register	Bytes	Data type	Access	Column	Line	Group	Description	Value (Display)	Value (Modbus)
2000	4	unsigned integer 32-bit	R	IP	1	E G O - M o d b u s	Vb totalizer	4044123 m3	00 3D B5 5B
2002	4	unsigned integer 32-bit	R	IP	2		Vm totalizer	114962 m3	00 01 C1 12
2004	4	unsigned integer 32-bit	R	IP	3		Energy totalizer	57809 MWh	00 00 E1 D1
2006	4	unsigned integer 32-bit	R	IP	4		Vb disturbance totalizer	675679 m3	00 0A 4F 5F
2008	4	unsigned integer 32-bit	R	IP	5		Vm disturbance totalizer	18095 m3	00 00 46 AF
2010	4	unsigned integer 32-bit	R	IP	6		Energy disturbance totalizer	7132 MWh	00 00 1B DC
2012	4	float IEEE 754	R	IP	7		Vb flow rate	6779.92 m3/h	45 D3 DF 5A
2014	4	float IEEE 754	R	IP	8		Vm flow rate	151.027 m3/h	43 17 06 FA
2016	4	float IEEE 754	R	IP	9		Energy flow rate	81359.0 kW	47 9E E7 84
2018	4	float IEEE 754	R/W	IP	10		Standard density	0.8000 kg/m3	3F 4C CC CD
2020	4	float IEEE 754	R/W	IP	11		Calorific value	12.000 kWh/m3	41 40 00 00
2022	4	float IEEE 754	R/W	IP	12		Hydrogen	0.00000 mol-%	00 00 00 00
2024	4	float IEEE 754	R/W	IP	13		Carbon dioxide	1.02041 mol-%	3F 82 9C BC
2026	4	float IEEE 754	R	IP	14		Operating density	35.914 kg/m3	42 0F A7 8C
2028	4	float IEEE 754	R	IP	15		Absolute pressure	42.000 bar	42 28 00 00
2030	4	float IEEE 754	R	IP	16		Temperature	10.00 °C	41 20 00 00
2032	2	unsigned integer 16-bit	R	IP	17		alarm	0	00 00

317

## 7 Overview: Coordinates

All menus, which are identified alphabetically, are listed in the appendix. A corresponding cross-reference to the menus listed in the preceding text is provided.

318

The hourly, daily and monthly quantities, documentation, parameterization, parameterization help and miscellaneous menus are listed separately in this chapter

### 7.1.1 LS Hourly quantities

#### LS Hourly quantities

Access	Line	Designation	Value	Unit	Variable
D	2	Last hour Vm	0	m3	<a href="#">lzStd_vu</a>
A *	3	Last hour Vb	0	*100 m3	<a href="#">lzStd_vn</a>
A *	4	Last hour E	0	MWh	<a href="#">lzStd_e</a>
D	5	Last hour M	0	*100 kg	<a href="#">lzStd_m</a>
D	6	Last hour Vc	0	m3	<a href="#">lzStd_vk</a>
D	12	Last hour Vm frac.	.000000	m3	<a href="#">lrStd_vu</a>
A *	13	Last hour Vb frac.	.000000	*100 m3	<a href="#">lrStd_vn</a>
A *	14	Last hour E frac.	.000000	MWh	<a href="#">lrStd_e</a>
D	15	Last hour M frac.	.000000	*100 kg	<a href="#">lrStd_m</a>
D	16	Last hour Vc frac.	.000000	m3	<a href="#">lrStd_vk</a>
D	22	Hour Vm	0	m3	<a href="#">czStd_vu</a>
A *	23	Hour Vb	0	*100 m3	<a href="#">czStd_vn</a>
A *	24	Hour E	0	MWh	<a href="#">czStd_e</a>
D	25	Hour M	0	*100 kg	<a href="#">czStd_m</a>
D	26	Hour Vc	0	m3	<a href="#">czStd_vk</a>
D	32	Hour Vm fraction	.000000	m3	<a href="#">crStd_vu</a>
A *	33	Hour Vb fraction	.000000	*100 m3	<a href="#">crStd_vn</a>
A *	34	Hour E fraction	.000000	MWh	<a href="#">crStd_e</a>
D	35	Hour M fraction	.000000	*100 kg	<a href="#">crStd_m</a>
D	36	Hour Vc fraction	.000000	m3	<a href="#">crStd_vk</a>

**Figure 232: Menu LS Hourly quantities**

Menus **LQ Monthly quantities**, **LS Hourly quantities**, **LT Daily quantities** and **LU quantity weighted average values** are strictly display menus. The quantities of the last hour LS02...LS16 are represented in the Modbus Register 1400...1428.

1400	4	unsigned integer 32-bit	R LS	2	Hourly quantities	hours Vb	222 m3
1402	4	unsigned integer 32-bit	R LS	3	Hourly quantities	hours Vn	2864 m3
1404	4	unsigned integer 32-bit	R LS	4	Hourly quantities	hours E	34 MWh
1406	4	unsigned integer 32-bit	R LS	5	Hourly quantities	hours M	7782 kg
1408	4	unsigned integer 32-bit	R LS	6	Hourly quantities	hours Vbk	222 m3



1420	4	float IEEE 754	R LS	12	Hourly quantities	hours Vb remainder	.345000 m3
1422	4	float IEEE 754	R LS	13	Hourly quantities	hours Vn remainder	.842821 m3
1424	4	float IEEE 754	R LS	14	Hourly quantities	hours E remainder	.378114 MWh
1426	4	float IEEE 754	R LS	15	Hourly quantities	hours M remainder	.075000 kg
1428	4	float IEEE 754	R LS	16	Hourly quantities	hours Vbk remainder	.345000 m3

## 7.2 Documentation

The documentation comprises 4 sub-chapters. Additional explanatory information is also provided here along with additional documents that can be opened by double-clicking on the [underlined](#) links.

320

### 7.2.1 Check numbers

#### Check numbers

	Version number	Check number	Date	Activation key
Flow computer BIOS	2.008	5AB5	21-10-2014 15:03:38	
Official kernel	1.8	1071	28-09-2018 12:02:07	
Application	1.8.0a	1F2C	11-10-2018 14:56:50	33587820
WinCE kernel	PicoMOD6 V1.11		Jun 18 2012	81455247

**Figure 233: Menu LS Hourly quantities**

These are internal check numbers to be used for identification.

### 7.2.2 Matrix

	AA	AB	AC	AD	AE	AF	AG	AH	AI	AJ	AK	AL	
1	o_m01	drka	temp	ho	rhon	dv	rhob	trhb	tvos	vsb	vsn	gerTemp	1
2	c_m02	drkaOll	tempOll	hoOll	rhonOll	dvOll	rhobOll	trhbOll	tvosOll	vsbOll	vsnOll	gerTempKty	2
3	c_m03	drkaMod	tempMod	hoMod	rhonMod	dvMod	rhobMod	trhbMod	tvosMod	vsbMod	vsnMod		3
4	c_m04	drkaDim	tempDim	hoDim	rhonDim	dvMod	rhobDim	trhbDim	tvosDim	vsbDim	vsnDim		4
5	o_m05	drkaVg	tempVg	hoVg	rhonVg	dvVg	rhobVg	trhbVg	tvosVg	vsbVg	vsnVg		5
6	c_m06	drkaWGwu	tempWGwu	hoWGwu	rhonWGwu	dvWGwu	rhobWGwu	trhbWGwu	tvosWGwu	vsbWGwu	vsnWGwu	gerTempGwo	6
7	o_m07	drkaWGwo	tempWGwo	hoWGwo	rhonWGwo	dvWGwo	rhobWGwo	trhbWGwo	tvosWGwo	vsbWGwo	vsnWGwo	gerTempGwu	7
8	c_m08	drkaAGwu	tempAGwu	hoAGwu	rhonAGwu	dvAGwu	rhobAGwu	trhbAGwu	tvosAGwu	vsbAGwu	vsnAGwu		8
9	c_m09	drkaAGwo	tempAGwo	hoAGwo	rhonAGwo	dvAGwo	rhobAGwo	trhbAGwo	tvosAGwo	vsbAGwo	vsnAGwo		9
10	o_m10	drkaK0	tempK0	hoK0	rhonK0	dvK0	rhobK0	trhbK0	tvosK0	vsbK0	vsnK0		10
11	o_m11	drkaK1	tempK1	hoK1	rhonK1	dvK1	rhobK1	trhbK1	tvosK1	vsbK1	vsnK1		11
12	o_m12	drkaK2	tempK2	hoK2	rhonK2	dvK2	rhobK2	trhbK2	tvosK2	vsbK2	vsnK2		12
13	o_m13	drkaK3	tempK3	hoK3	rhonK3	dvK3	rhobK3	trhbK3	tvosK3	vsbK3	vsnK3		13
14	o_m14												14
15	o_m15												15
16	o_m16												16
17	o_m17												17
18	o_m18												18
19	o_m19	drkaInp	tempInp	hoInp	rhonInp	dvInp	rhobInp	trhbInp	tvosInp	vsbInp	vsnInp		19
20	o_m20				rhonInp2								20
21	o_m21	drkaKorr	tempKorr	hoKorr	rhonKorr	dvKorr	vskrMod	trhbKorr	tvosKorr	vsbKorr	vsnKorr	gerOffs	21
22	o_m22	drkaMGdt	tempMGdt	hoMGdt	rhonMGdt	dvMGdt	rhobMGdt	trhbMGdt	tvosMGdt	vsbMGdt	vsnMGdt		22
23	c_m23			hoToMx	rhonToMx	dvToMx							23
24	o_m24	drkaOrg	tempOrg	hoOrg	rhonOrg	dvOrg	rhobOrg	trhbOrg	tvosOrg	vsbOrg	vsnOrg		24
25	c_m25	drkaEmiw	tempEmiw	hoEmiw	rhonEmiw	dvEmiw	rhobEmiw	trhbEmiw	tvosEmiw	vsbEmiw	vsnEmiw		25
26	o_m26		dt		rhonOll2		rhobu			vsbAbw		gerTempHex	26
27	c_m27	drkaCEstt	tempCEstt	hoCEstt	rhonCEstt	dvCEstt	rhobCEstt	trhbCEstt	tvosCEstt	vsbCEstt	vsnCEstt		27
28	o_m28	drkaEstt	tempEstt	hoEstt	rhonEstt	dvEstt	rhobEstt	trhbEstt	tvosEstt	vsbEstt	vsnEstt		28
29	c_m29	drkaMb	tempMb	hoMb	rhonMb	dvMb	rhobMb	trhbMb	tvosMb	vsbMb	vsnMb		29
30	o_m30	drkaFrm	tempFrm	hoFrm	rhonFrm	dvFrm	rhobFrm	trhbFrm	tvosFrm	vsbFrm	vsnFrm		30
31	o_m31	drkaMn	tempMn	hoMn	rhonMn	dvMn	rhobMn	trhbMn	tvosMn	vsbMn	vsnMn		31
32	o_m32	drkaMx	tempMx	hoMx	rhonMx	dvMx	rhobMx	trhbMx	tvosMx	vsbMx	vsnMx		32
33	o_m33	drkaGdt	tempGdt	hoGdt	rhonGdt	dvGdt	rhobGdt	trhbGdt	tvosGdt	vsbGdt	vsnGdt		33
34	o_m34	drkaSmiv	tempSmiv	hoSmiv	rhonSmiv	dvSmiv	rhobSmiv	trhbSmiv	tvosSmiv	vsbSmiv	vsnSmiv		34
35	o_m35	drkaMmiw	tempMmiw	hoMmiw	rhonMmiw	dvMmiw	rhobMmiw	trhbMmiw	tvosMmiw	vsbMmiw	vsnMmiw		35
36		drkaHmiw	tempHmiw	hoHmiw	rhonHmiw	dvHmiw	rhobHmiw	trhbHmiw	tvosHmiw	vsbHmiw	vsnHmiw		36
37		drkaCEmiw	tempCEmiw	hoCEmiw	rhonCEmiw	dvCEmiw	rhobCEmiw	trhbCEmiw	tvosCEmiw	vsbCEmiw	vsnCEmiw		37
38		drkaStAb	tempStAb	hoStAb	rhonStAb	dvStAb	rhobStAb	trhbStAb	tvosStAb	vsbStAb	vsnStAb		38
39				hoTb1	rhonTb1	dvTb1							39
40				hoTb2	rhonTb2	dvTb2							40
41				hoTb3	rhonTb3	dvTb3							41
42				hoTb4	rhonTb4	dvTb4							42
43				hoToAct	rhonToAct	dvToAct							43
44				hoHalte	rhonHalte						vsnHalte		44
45				hoPruef	rhonPruef								45

Figure 235: Menu Documentation / Matrix

An assignment of variables to the menus and the corresponding lines of the coordinate system is shown in this matrix.

## 7.2.3 Document creation

### Absolute pressure

Access	Column	Line	Designation	Minimum	Maximum	Unit
A	AB	1	Measured value			var. Unit see AB 4
A	AB	2	Input value			var. Unit see AB 19
E	AB	3	<b>Operating mode</b>	Menu		<b>none</b> OFF; Default; From gauge press.; Meas.v.=source v.; Polynom. 1st order; Polynom. 2nd order; Polynom. 3rd order; 4-20mA co
G	AB	4	<b>Unit</b>	Menu		<b>none</b> bar; kgf/cm2; psi; MPa; atm; kPa; torr; bara; Pa; hPa;
B	AB	5	<b>Default</b>	0.00000 bar	600.00000 bar	<b>var.</b> Unit see AB 4
B	AB	6	<b>Lower warning limit</b>	0.00000 bar	600.00000 bar	<b>var.</b> Unit see AB 4
B	AB	7	<b>Upper warning limit</b>	0.00000 bar	600.00000 bar	<b>var.</b> Unit see AB 4
E	AB	8	<b>Lower alarm limit</b>	0.00000 bar	600.00000 bar	<b>var.</b> Unit see AB 4
E	AB	9	<b>Upper alarm limit</b>	0.00000 bar	600.00000 bar	<b>var.</b> Unit see AB 4
E	AB	10	<b>Coefficient 0</b>	Unlimited	Unlimited	<b>none</b>
E	AB	11	<b>Coefficient 1</b>	Unlimited	Unlimited	<b>none</b>
E	AB	12	<b>Coefficient 2</b>	Unlimited	Unlimited	<b>none</b>
E	AB	13	<b>Coefficient 3</b>	Unlimited	Unlimited	<b>none</b>
E	AB	19	<b>Source</b>	Menu		<b>none</b> OFF; Current 1; Current 2; Current 3; Current 4; Current 5; Current 6; Current 7; Current 8; Frequency 1; Frequency 2; Frequ
E	AB	21	<b>Correction value</b>	-5.00000 bar	5.00000 bar	<b>var.</b> Unit see AB 4
E	AB	22	<b>Max. gradient</b>	0 bar/s	100 bar/s	<b>var.</b> Unit see AB 4
D	AB	24	Base value			var. Unit see AB 4
D	AB	25	Mean for DSFG			var. Unit see AB 4
D	AB	27	Current status	Discrete texts		<b>none</b> Okay; Stop; Default value; Fixed value; Holding value;
D	AB	28	DSFG status	Discrete texts		<b>none</b> Okay; Stop; Default value; Fixed value; Holding value;
D	AB	29	Used range			var. Unit see AB 4
G	AB	30	<b>Format</b>	Menu		<b>none</b> %;0f; %;1f; %;2f; %;3f; %;4f; %;5f; %;6f; %g; %e; %f;
D	AB	31	Min. drag indicator			var. Unit see AB 4
D	AB	32	Max. drag indicator			var. Unit see AB 4
D	AB	33	Current gradient			var. Unit see AB 4
D	AB	34	Second mean			var. Unit see AB 4
D	AB	35	Minute mean			var. Unit see AB 4
D	AB	36	Hourly mean			var. Unit see AB 4
D	AB	37	Ongoing mean			var. Unit see AB 4
D	AB	38	Standard deviation			var. Unit see AB 4
D	AB	47	Revision mean			var. Unit see AB 4
D	AB	48	retain value			var. Unit see AB 4
D	AB	49	Daily mean			var. Unit see AB 4
E	AB	50	<b>Manufacturer</b>	Unlimited	Unlimited	<b>none</b>
E	AB	51	<b>Device type</b>	Unlimited	Unlimited	<b>none</b>
E	AB	52	<b>Serial number</b>	Unlimited	Unlimited	<b>none</b>
F	AB	61	Measured value			var. Unit see AB 1
F	AB	62	Input value			var. Unit see AB 2

### Gas temperature

Access	Column	Line	Designation	Minimum	Maximum	Unit
A	AC	1	Measured value			var. Unit see AC 4
A	AC	2	Input value			var. Unit see AC 19
E	AC	3	<b>Operating mode</b>	Menu		<b>none</b> OFF; Default; PT100,500,1000; Meas.v.=source v.; Polynom. 1st order; Polynom. 2nd order; Polynom. 3rd order; 4-20mA coeff.; 0
G	AC	4	<b>Unit</b>	Menu		<b>none</b> °C; °F; K; °Ra;
B	AC	5	<b>Default</b>	-60.00 °C	90.00 °C	<b>var.</b> Unit see AC 4
B	AC	6	<b>Lower warning limit</b>	-60.00 °C	90.00 °C	<b>var.</b> Unit see AC 4
B	AC	7	<b>Upper warning limit</b>	-60.00 °C	90.00 °C	<b>var.</b> Unit see AC 4
E	AC	8	<b>Lower alarm limit</b>	-60.00 °C	90.00 °C	<b>var.</b> Unit see AC 4
E	AC	9	<b>Upper alarm limit</b>	-60.00 °C	90.00 °C	<b>var.</b> Unit see AC 4
E	AC	10	<b>Coefficient 0</b>	Unlimited	Unlimited	<b>none</b>

**Figure 236: Menu Documentation / Document creation**

All menus (columns), including the content are listed again here. Automatic adoption of this data to the documentation took place earlier and now the user can decide which parts to add to the documentation.

## 7.2.4 Documentation

### Documentation

- I. Flow computer
  - 1. Adjustments of COM1 Interface
    - a. [RS232](#)
    - b. [RS422](#)
    - c. [RS485](#)
  - 2. Block Diagrams
    - a. [Inputs](#)
    - b. [Outputs](#)
    - c. [Volume](#)
  - 3. Formulas
    - a. [Volume](#)
    - b. [Analogue Inputs](#)
    - c. [Frequency Inputs](#)
    - d. [Density Correction](#)
    - e. [Gas Meter Error curve linearization Flow rate](#)
    - f. [Gas Meter Error curve linearization Reynolds number](#)
    - g. [Gas Meter Error curve linearization interpolation point method](#)
- II. DSfG
  - 1. Data Elements
    - a. [Flow computer](#)
    - b. [Registration](#)
    - c. [Remote data transmission](#)
    - d. [Flow meter](#)
  - 2. [Events](#)
- III. MODBUS
  - 1. [Registers](#)
  - 2. [Registers Werne project](#)
  - 3. [Registers Transgas project](#)
  - 4. [Bits für regulation](#)
  - 5. [Coils](#)
- IV. [Error table](#)

323

---

Please have patience with longer loading times.

### **Figure 237: Menu Documentation / Documentation**

Documents that offer additional explanations for the specified points beyond the manual.

## 7.3 Parameterization

This menu has 4 submenus.

### 7.3.1 Parameterizing data

#### List of parameters

##### Identification

Vers.offic.kernel	1.7
Checks.offic.kernel	1792
Version application	1.7.0
Checks. application	BBE9
Version FC BIOS	2.008
Checks. FC BIOS	5AB5
FC-BIOS bootloader	1.05
kernel	PicoMOD6 V1.11
kernel CRC	81455247
kernel bootloader	1.10
SVN revisions	1219_179_220
checksum parameter	30537
Year of construct.	2013
Factory number	1234567890123456789
Hardware ID	10
MAC-address Eth1	00-05-51-05-1A-FC
MAC-address Eth2	00-00-00-00-00-00
Measuring point	Gas1 p5
Owner	Besitzer
Start-up	01-01-1970 01:00:00

##### AB Absolute pressure

3	Absolute pressure, operating mode	Default	*
4	Absolute pressure, selection of unit	MPa	*
5	Absolute pressure, default value	0.55000	MPa
6	Absolute pressure, lower warning limit	0.10000	MPa
7	Absolute pressure, upper warning limit	1.00000	MPa
8	Absolute pressure, lower alarm limit	0.10000	MPa
9	Absolute pressure, upper alarm limit	1.00000	MPa
10	Absolute pressure, coefficient 0	0	*
11	Absolute pressure, coefficient 1	0	*
12	Absolute pressure, coefficient 2	0	*
13	Absolute pressure, coefficient 3	0	*
19	Absolute pressure, selection of input value	OFF	*
21	Absolute pressure, correction value	0.30000	MPa
22	Absolute pressure, maximum gradient	10	MPa/s
30	Absolute pressure, selection of format	%.5f	*

**Figure 238: Menu Parameterization / Parameterizing data**

A list of the relevant parameterizations is provided here.

### 7.3.2 Calibration data

#### AB Absolute pressure

3	Absolute pressure, operating mode	Default		*
8	Absolute pressure, lower alarm limit	0.10000	MPa	*
9	Absolute pressure, upper alarm limit	1.00000	MPa	*
10	Absolute pressure, coefficient 0	0		*
11	Absolute pressure, coefficient 1	0		*
12	Absolute pressure, coefficient 2	0		*
13	Absolute pressure, coefficient 3	0		*
19	Absolute pressure, selection of input value	OFF		*
21	Absolute pressure, correction value	0.30000	MPa	*
22	Absolute pressure, maximum gradient	10	MPa/s	*
50	Manufacturer of absolute pressure transmitter	ROSEMOUNT		*
51	Device type, absolute pressure transmitter	3051S1CA2		*
52	Serial number of absolute pressure transmitter	0		*

#### AC Gas temperature

3	Temperature, operating mode	Default		*
8	Temperature, lower alarm limit	253.15	K	*
9	Temperature, upper alarm limit	323.15	K	*
10	Temperature, coefficient 0	0		*
11	Temperature, coefficient 1	0		*
12	Temperature, coefficient 2	0		*
13	Temperature, coefficient 3	0		*
19	Temperature, selection of input value	OFF		*
21	Temperature, correction value	0.00	K	*
22	Temperature, maximum gradient	10	K/s	*
50	Manufacturer of temperature transmitter	ROSEMOUNT		*
51	Device type, temperature transmitter	Pt100		*
52	Serial number of temperature transmitter	0		*

#### AD Superior calorific value

3	Superior calorific value, operating mode	4-20mA lim.		*
8	Superior calorific value, lower alarm limit	7.000	kWh/m3	*
9	Superior calorific value, upper alarm limit	14.000	kWh/m3	*
10	Superior calorific value, coefficient 0	0		*
11	Superior calorific value, coefficient 1	0		*
12	Superior calorific value, coefficient 2	0		*
13	Superior calorific value, coefficient 3	0		*
19	Superior calorific value, selection of input value	Current 1		*
21	Superior calorific value, correction value	0.000	kWh/m3	*
22	Superior calorific value, maximum gradient	10	kWh/m3/s	*
45	Superior calorific value of test gas	11.061	kWh/m3	*
46	Maximum permissible correction value	0.300	kWh/m3	*
50	Manufacturer of superior calorific value transmitter	RMG		*
51	Device type, superior calorific value transmitter	GC		*
52	Serial number of superior calorific value transmitter	0		*

**Figure 239: Menu Parameterization / Calibration data**

The custody transfer parameters from all parameters are displayed here.

### 7.3.3 Changes

[zum Jüngsten](#)

#### Änderungen

##### 10.01.80 02:27:23

(Neustart) E IA32 Media Access Control Ethernet ID Ethernet 2  
Parameter 'macAddrE2='00-05-51-00-00-00' nicht geladen

##### 10.01.80 02:37:01

(Neustart) E IA32 Media Access Control Ethernet ID Ethernet 2  
Parameter 'macAddrE2='00-05-51-00-00-00' nicht geladen

##### 10.01.80 02:38:21

(Browser) Y FG43 Pr□e  
Menu: aus -> Kalibrierhilfe

##### 10.01.80 02:41:02

(Browser) E IA32 Media Access Control Ethernet ID Ethernet 2  
String: '00-05-51-00-00-00' -> '00-05-51-05-9B-4A'

##### 10.01.80 03:21:55

(Browser) E IA32 Media Access Control Ethernet ID Ethernet 2  
String: '00-05-51-05-9B-4A' -> '00-05-51-05-8B-4A'

##### 10.01.80 03:22:24

(Fertigung) E NI13 Messbereich  
Menu: PT100 -> PT1000

##### 10.01.80 03:22:33

...

Menu: TM -> USM

##### 26.09.18 13:41:31

(Browser) B EE01 Language setting  
Menu: English -> German

##### 26.09.18 13:42:12

(Browser) B EE01 Spracheinstellung  
Menu: deutsch -> englisch

##### 26.09.18 14:24:26

(Browser) E IM50 Modbus Master 2 operating mode  
Menu: OFF -> Modbus-serial C6

(Browser) E IM51 Modbus Master 2 IP-Address  
ip4: 192.168.20.144 -> 10.20.13.71

##### 26.09.18 14:24:59

(Browser) E VK50 Modbus Master 3 operating mode  
Menu: OFF -> Modbus-serial C6

##### 27.09.18 11:12:42

(Browser) E AD03 Superior calorific value, operating mode  
Menu: Default -> 4-20mA lim.

(Browser) E AD19 Superior calorific value, selection of input value  
Menu: OFF -> Current 1

[Go to top](#)

**Figure 240: Menu Parameterization / Calibration data**

This menu lists all parameter changes that have been made, listed by time.



### 7.3.4 Saving and loading

**Saving**

The saving of all ERZ 2000 parameters on your PC can take place by reading back the  lodged file and save it under a significant name.

**Loading**

Downloading of all parameters from your PC into the ERZ2000 can take place by filling out the complete path of the saved file (ERZ2000 has to be in Superuser-Mode)

here and than send off

Uploading takes a few seconds (download-speed is faster). After uploading appears a table with all changed parameters. Please notice the marked lines and carry out the instructions.

**Warning**

Avoid to alter the saved file, changig data can cause damage of the system. If necessary use an editor with terminal-font and follow exactly the given syntax. Always use as an example an original saved file. Do not change the order of parameters. Do not change the notation of parameter names. Parameters in menus must have the exact value.

Do not send any files to engage ERZ2000 useless. The device will not accept these data. The device will not accept files with more than 50000 characters and will stop uploading immediately. In such a case the ERZ 2000 does not take any care of your browser or your PC.

**Figure 241: Menu Parameterization | Saving and loading**

This menu is provided for saving, reading and adjusting the settings of the ERZ2000-NG.

## 7.4 Parameterization help

The parameterization help chapter has only one submenu.

### 7.4.1 Support for inputting components

#### Support for inputting components

Components	Default	Table value 1	Table value 2	Table value 3	Table value 4	Unit
Sup.calorific val.	11.250	9.188	10.000	10.000	10.000	kWh/m <sup>3</sup>
Standard density	0.75651	0.89690	0.80000	0.80000	0.80000	kg/m <sup>3</sup>
Relative density	0.5549	0.5549	0.5549	0.5549	0.5549	
Carbon dioxide	0.9960	6.2000	1.0000	1.0000	1.0000	mole%
Hydrogen	1.0000	0.0000	0.0000	0.0000	0.0000	mole%
Nitrogen	0.2988	10.0000	0.0000	0.0000	0.0000	mole%
Methane	95.1155	100.0000	100.0000	100.0000	100.0000	mole%
Ethane	1.7928	0.0000	0.0000	0.0000	0.0000	mole%
Propane	0.4482	0.0000	0.0000	0.0000	0.0000	mole%
N-butane	0.0996	0.0000	0.0000	0.0000	0.0000	mole%
I-butane	0.0996	0.0000	0.0000	0.0000	0.0000	mole%
N-pentane	0.0299	0.0000	0.0000	0.0000	0.0000	mole%
I-pentane	0.0498	0.0000	0.0000	0.0000	0.0000	mole%
Neo-pentane	0.0000	0.0000	0.0000	0.0000	0.0000	mole%
Hexane	0.0697	0.0000	0.0000	0.0000	0.0000	mole%
Heptane	0.0000	0.0000	0.0000	0.0000	0.0000	mole%
Octane	0.0000	0.0000	0.0000	0.0000	0.0000	mole%
Nonane	0.0000	0.0000	0.0000	0.0000	0.0000	mole%
Decane	0.0000	0.0000	0.0000	0.0000	0.0000	mole%
Hydrogen sulphide	0.0000	0.0000	0.0000	0.0000	0.0000	mole%
Water	0.0000	0.0000	0.0000	0.0000	0.0000	mole%
Helium	0.0000	0.0000	0.0000	0.0000	0.0000	mole%
Oxygen	0.0000	0.0000	0.0000	0.0000	0.0000	mole%
Carbon monoxide	0.0000	0.0000	0.0000	0.0000	0.0000	mole%
Ethene	0.0000	0.0000	0.0000	0.0000	0.0000	mole%
Propene	0.0000	0.0000	0.0000	0.0000	0.0000	mole%
Argon	0.0000	0.0000	0.0000	0.0000	0.0000	mole%
	ISO 6976	ISO 6976	ISO 6976	ISO 6976	ISO 6976	

Enter Cancel

**Figure 242: Menu Parameterization help / Support for inputting components**

Gas compositions can be entered here in 4 different tables. They can be used for calculation of the additional gas parameters instead of, for example, values measured by a PGC.

## 7.5 Miscellaneous

There are 7 submenus under Miscellaneous.

### 7.5.1 Fault display

Active	Fault number	Short text	Long text
+	M54-0	Calibr. lock	Calibration lock is open
+	A93-6	USZ timeout	No more signal from USZ transmitter
+	H40-3	C6 conflict	Serial interface C6 protocol in conflict

Acknowledge faults

Designation	Number	Contact	LED
Alarm	1	+	Flashes
Warning	0	-	OFF

Figure 243: Menu Miscellaneous / Fault display

Pending faults with fault numbers are listed in this menu. Acknowledgment corresponding to that of the touch screen is possible.

### 7.5.2 Frozen values

#### Frozen values

Date and time of last freeze : 27-09-2018 15:00:00

#### AB Freeze absolute pressure

61	Freeze measured value for absolute pressure	0.55000	MPa
62	Freeze input value for absolute pressure	0.55	MPa

#### AC Freeze temperature

61	Freeze measured value for temperature	293.15	K
62	Freeze input value for temperature	293.15	K

#### AD Freeze superior calorific value

61	Freeze measured value for superior calorific value	11.250	kWh/m3
62	Freeze input value for superior calorific value	0.00254238	mA

#### AE Freeze standard density

Figure 244: Menu Miscellaneous / Frozen values

Values of the last freeze process are listed here.

### 7.5.3 Interface variables

#### interface variables from/to outside device

##### AL Inside temperature of device

26	Converter value	005BA000	hex
----	-----------------	----------	-----

##### EH Module assembly

2	Module slot 1A assembly / module type	Passive	
3	Module slot 1A identification	0	
4	Module slot 1A version	0.00	
5	Module slot 1A status 1	0000	hex
6	Module slot 1A status 2	0000	hex
7	Module slot 1A status 3	0000	hex
8	Module slot 1A status 4	0000	hex
12	Module slot 1B assembly / module type	Unknown	
13	Module slot 1B identification	0	
14	Module slot 1B version	0.00	
15	Module slot 1B status 1	0000	hex
16	Module slot 1B status 2	0000	hex
17	Module slot 1B status 3	0000	hex
18	Module slot 1B status 4	0000	hex
22	Module slot 2A assembly / module type	Unknown	
23	Module slot 2A identification	0	
24	Module slot 2A version	0.00	
25	Module slot 2A status 1	0000	hex
26	Module slot 2A status 2	0000	hex
27	Module slot 2A status 3	0000	hex
28	Module slot 2A status 4	0000	hex
32	Module slot 2B assembly / module type	Unknown	
33	Module slot 2B identification	0	
34	Module slot 2B version	0.00	
35	Module slot 2B status 1	0000	hex
36	Module slot 2B status 2	0000	hex
37	Module slot 2B status 3	0000	hex
38	Module slot 2B status 4	0000	hex
42	Module slot 3A assembly / module type	Active	
43	Module slot 3A identification	300	
44	Module slot 3A version	1.10	
45	Module slot 3A status 1	0000	hex
46	Module slot 3A status 2	0000	hex
47	Module slot 3A status 3	0031	hex
48	Module slot 3A status 4	0297	hex
49	Namur status of exi module of slot 3A	0004	hex
52	Module slot 3B assembly / module type	Unknown	
53	Module slot 3B identification	0	

##### EJ Identification of software

7	Version of flow computer BIOS	2.008	
8	Checksum of flow computer BIOS	5AB5	hex
9	Time stamp of flow computer BIOS	21-10-2014 15:03:38	

Figure 245: Menu Miscellaneous / Interface variables

Interface variables are variables that transmit custody transfer information or effect the representation of custody transfer information but are not (permanently) subject to custody transfer requirements.

**Example**

**IH RMG bus**

ERZ2000-NG is connected to Stream 1. If the measurements of Stream 2, 3, 4 or the sample gas are on **IH46 current stream .. IH77 24K tg: C3H6**, the data is irrelevant.

These values only transport custody transfer data if Stream 1 is displayed and the status = "okay".

**7.5.4 View log**

[View log](#)

**New entry**

Editor:

Entry:

**Figure 246: Menu Miscellaneous / View log**

Entries that are helpful for documentation can be made in the log book.

## 7.5.5 Binary code check

### Binary code control

Module	Start of Code	End of Code	Initial Checksum	Current Checksum	No. of checks okay	No. of checks error
ERZ3000App	00011000	00011E24	690e	690e	4438	0
erzmmain	00014E00	00017564	31f5	31f5	4438	0
abgas	00017588	00019698	3834	3834	4438	0
aga10	000196BC	00022EF8	f3c1	f3c1	4438	0
aga8	00022F1C	00025AA0	59a5	59a5	4438	0
aganx	00025AC4	00028748	1902	1902	4438	0
approxkmp	0002876C	000291B0	7195	7195	4438	0
ausdehnung	000291D4	000299FC	44e8	44e8	4438	0
beattie	00029A20	0002AE7C	dc20	dc20	4438	0
blende	0002AEA0	0002F848	30b2	30b2	4438	0
bodycomp	0002F86C	0002FED8	0097	0097	4438	0
compoflow	0002FEFC	00030060	fde4	fde4	4438	0
components	00030084	000326D0	382c	382c	4438	0
deltap	000326F4	00035414	d629	d629	4438	0
dimens	00035438	0003A6E4	7f72	7f72	4438	0
finstanz	0003A708	0003DF50	17b0	17b0	4438	0
fliegeich	0003DF74	0003E25C	372f	372f	4438	0
flowwarning	0003E280	0003E5B0	cab4	cab4	4438	0
formeln	0003E5D4	0003FCE0	f141	f141	4438	0
freeze	0003FD04	00041630	fa72	fa72	4438	0
gaskonst	00041654	00041B30	a490	a490	4438	0
gerg	00041B54	00046014	8dc7	8dc7	4438	0
iso6976	00046038	00048600	f141	f141	4438	0
kelipoly	00048624	00048DC4	fde4	fde4	4438	0
kelistzp	00048DE8	0004944C	373a	373a	4438	0
kmpbusctrl	00049470	00049ED8	d4c1	d4c1	4438	0
mathedanach	00049EFC	0004F520	f6a0	f6a0	4438	0
mathezuvor	0004F544	00051228	99bc	99bc	4438	0
mathezwischen	0005124C	000524BC	6373	6373	4438	0
methanzahl	000524E0	00052C40	73a6	73a6	4438	0
mngwicht	00052C64	00052F00	a3c1	a3c1	4438	0
mnmxmw	00052F24	00054998	35af	35af	4438	0
mswkorr	000549BC	000556CC	1540	1540	4438	0
normalize	000556F0	00056F20	d801	d801	4438	0
ohm2grad	00056F44	000579E0	0068	0068	4438	0
pengrobinson	00057A04	0005A96C	34f4	34f4	4438	0
qproportional	0005A990	0005ADB8	9633	9633	4438	0
stoechio	0005ADDC	0005B7F0	3230	3230	4438	0
swpulsvgl	0005B814	0005D6B0	cc60	cc60	4438	0
ultrason	0005D6D4	00063DB4	4fb5	4fb5	4438	0
ultrason	00063E0C	00064B80	21f2	21f2	4438	0

**Figure 247: Menu Miscellaneous / Binary code check**

The checksum of each individual part of the software is continuously checked again in this menu. In the process – as already explained in the introduction – **dark yellow: subject to official custody transfer requirements** and **light yellow** means not subject to official custody transfer requirement.

Whether individual parts or the entire software works correctly can be seen here. For example, whether a program memory has been damaged due to lightning can be recognized here.

With WinCE, changes in the multi-user functionality can be recognized if a virus or hacker manipulates the code.

## 7.5.6 TSV export

### TSV export

#### Archive group 1: counters and measured values billing mode 1

Ordinal No.	Number	state	from	to
<a href="#">13001 ... 13107</a>	107	grows	23-09-2018 08:00:00	27-09-2018 16:00:00
<a href="#">12501 ... 13000</a>	500	complete	03-09-2018 12:00:00	23-09-2018 07:00:00
<a href="#">12001 ... 12500</a>	500	complete	13-08-2018 16:00:00	03-09-2018 11:00:00
<a href="#">11501 ... 12000</a>	500	complete	25-06-2018 14:00:00	13-08-2018 15:00:00
<a href="#">11001 ... 11500</a>	500	complete	04-06-2018 20:00:00	25-06-2018 13:00:00
<a href="#">10501 ... 11000</a>	500	complete	15-05-2018 00:00:00	04-06-2018 19:00:00
<a href="#">10001 ... 10500</a>	500	complete	24-04-2018 04:00:00	14-05-2018 23:00:00
<a href="#">9501 ... 10000</a>	500	complete	03-04-2018 10:00:00	24-04-2018 03:00:00
<a href="#">9001 ... 9500</a>	500	complete	13-03-2018 13:00:00	03-04-2018 09:00:00
<a href="#">8501 ... 9000</a>	500	complete	20-02-2018 17:00:00	13-03-2018 12:00:00
<a href="#">8001 ... 8500</a>	500	complete	30-01-2018 21:00:00	20-02-2018 16:00:00
<a href="#">7501 ... 8000</a>	500	complete	10-01-2018 01:00:00	30-01-2018 20:00:00
<a href="#">7001 ... 7500</a>	500	complete	18-12-2017 19:00:00	10-01-2018 00:00:00
<a href="#">6501 ... 7000</a>	500	complete	03-06-2017 20:00:00	18-12-2017 18:00:00
<a href="#">6001 ... 6500</a>	500	complete	12-05-2017 12:00:00	03-06-2017 19:00:00
<a href="#">5501 ... 6000</a>	500	complete	22-04-2017 14:00:00	12-05-2017 11:00:00
<a href="#">5001 ... 5500</a>	500	complete	01-04-2017 23:00:00	22-04-2017 13:00:00
<a href="#">4916 ... 5000</a>	85	shrinks	29-03-2017 10:00:00	01-04-2017 22:00:00

333

#### Archive group 2: disturbance counters billing mode 1

Ordinal No.	Number	state	from	to
<a href="#">6501 ... 6554</a>	54	grows	13-09-2018 02:00:00	27-09-2018 16:00:00
<a href="#">6001 ... 6500</a>	500	complete	23-08-2018 13:00:00	13-09-2018 01:00:00
<a href="#">5501 ... 6000</a>	500	complete	02-08-2018 17:00:00	23-08-2018 12:00:00
<a href="#">5001 ... 5500</a>	500	complete	11-06-2017 18:00:00	02-08-2018 16:00:00
<a href="#">4501 ... 5000</a>	500	complete	20-05-2017 03:00:00	11-06-2017 17:00:00
<a href="#">4001 ... 4500</a>	500	complete	10-04-2017 20:00:00	20-05-2017 02:00:00
<a href="#">3501 ... 4000</a>	500	complete	21-03-2017 04:00:00	10-04-2017 19:00:00
<a href="#">3001 ... 3500</a>	500	complete	28-02-2017 08:00:00	21-03-2017 03:00:00
<a href="#">2501 ... 3000</a>	500	complete	25-01-2017 15:00:00	28-02-2017 07:00:00
<a href="#">2001 ... 2500</a>	500	complete	26-02-2016 12:18:04	25-01-2017 14:00:00
<a href="#">1501 ... 2000</a>	500	complete	24-10-2014 11:00:00	26-02-2016 12:17:06
<a href="#">1001 ... 1500</a>	500	complete	16-05-2014 13:00:00	24-10-2014 10:00:00
<a href="#">501 ... 1000</a>	500	complete	08-01-2014 10:46:37	16-05-2014 12:00:00
<a href="#">1 ... 500</a>	500	complete	18-01-2023 16:04:49	08-01-2014 10:46:32

#### Archive group 3: counters and measured values billing mode 2

Ordinal No.	Number	state	from	to
<a href="#">13001 ... 13107</a>	107	grows	23-09-2018 08:00:00	27-09-2018 16:00:00
<a href="#">12501 ... 13000</a>	500	complete	03-09-2018 12:00:00	23-09-2018 07:00:00
<a href="#">12001 ... 12500</a>	500	complete	13-08-2018 16:00:00	03-09-2018 11:00:00
<a href="#">11501 ... 12000</a>	500	complete	25-06-2018 14:00:00	13-08-2018 15:00:00
<a href="#">11001 ... 11500</a>	500	complete	04-06-2018 20:00:00	25-06-2018 13:00:00

...

**Archive group 18: values for function test (revision) part 2**

Ordinal No.	Number	state	from	to
<a href="#">5 ... 8</a>	4	grows	19-09-2018 11:26:01	19-09-2018 11:29:01

**Archive group 19: values for function test (revision) part 3**

Ordinal No.	Number	state	from	to
<a href="#">5 ... 8</a>	4	grows	19-09-2018 11:26:01	19-09-2018 11:29:01

**Archive group 20: values for function test (revision) part 4**

Ordinal No.	Number	state	from	to
<a href="#">5 ... 8</a>	4	grows	19-09-2018 11:26:01	19-09-2018 11:29:01

**Archive group 21: log file alarms, warnings and other messages**

Ordinal No.	Number	state	from	to
<a href="#">4501 ... 4836</a>	336	grows	13-09-2018 11:21:24	26-09-2018 14:25:00
<a href="#">4001 ... 4500</a>	500	complete	16-02-2017 15:39:20	13-09-2018 11:21:24
<a href="#">3501 ... 4000</a>	500	complete	17-03-2016 12:04:06	16-02-2017 15:38:42
<a href="#">3001 ... 3500</a>	500	complete	09-03-2016 14:43:08	17-03-2016 12:04:05
<a href="#">2501 ... 3000</a>	500	complete	29-01-2015 11:29:08	09-03-2016 14:41:49
<a href="#">2001 ... 2500</a>	500	complete	22-07-2014 14:36:01	29-01-2015 11:29:08
<a href="#">1501 ... 2000</a>	500	complete	21-03-2014 08:11:38	22-07-2014 14:36:01
<a href="#">1001 ... 1500</a>	500	complete	16-12-2013 14:27:24	21-03-2014 08:10:50
<a href="#">501 ... 1000</a>	500	complete	19-09-2013 08:58:29	16-12-2013 14:27:24
<a href="#">1 ... 500</a>	500	complete	07-02-2106 07:17:01	19-09-2013 08:58:29

**Archive group 22: maximum load values of day**

Ordinal No.	Number	state	from	to
<a href="#">527 ... 706</a>	180	grows	04-03-2018 15:00:00	27-09-2018 15:00:00

**Archive group 23: maximum load values of month**

Ordinal No.	Number	state	from	to
<a href="#">1 ... 20</a>	20	grows	01-07-2013 15:00:00	01-09-2018 15:00:00

**Archive group 24: maximum load values of year**

Ordinal No.	Number	state	from	to
<a href="#">1 ... 1</a>	1	grows	01-01-2018 15:00:00	01-01-2018 15:00:00

**TSV command**

```
GNU Wget: wget -r http://xxx.xxx.xxx.xxx/dyntsvexport.htm
```

**Figure 248: Menu Miscellaneous / TSV export**

All saved archive groups are listed here. They can be opened or saved by double-clicking on the [indenture numbers](#). The complete groups no longer change and can be saved. The other groups are still growing and thus not complete.



## 7.5.7 Exceptions

```

1 (SVN-Rev=720) (4594) code=<0xE06D7369/EXCEPTION_CSimpleException>, ExceptionAddress=<4006870C>, NumberParameters=<3>, ExceptionFlags=<1>
  ExceptionInformation[0]=<429065504/0x19930520>
  ExceptionInformation[1]=<7404568/0x70FC18>
  ExceptionInformation[2]=<3966116/0x3C84A4>
2 (SVN-Rev=720) (4594) code=<0xE06D7369/EXCEPTION_CSimpleException>, ExceptionAddress=<4006870C>, NumberParameters=<3>, ExceptionFlags=<1>
  ExceptionInformation[0]=<429065504/0x19930520>
  ExceptionInformation[1]=<7404568/0x70FC18>
  ExceptionInformation[2]=<3965868/0x3C83AC>
3 (SVN-Rev=720) (4594) code=<0xE06D7369/EXCEPTION_CSimpleException>, ExceptionAddress=<4006870C>, NumberParameters=<3>, ExceptionFlags=<1>
  ExceptionInformation[0]=<429065504/0x19930520>
  ExceptionInformation[1]=<7404568/0x70FC18>
  ExceptionInformation[2]=<3966048/0x3C8460>
4 (SVN-Rev=720) (4594) code=<0xE06D7369/EXCEPTION_CSimpleException>, ExceptionAddress=<4006870C>, NumberParameters=<3>, ExceptionFlags=<1>
  ExceptionInformation[0]=<429065504/0x19930520>
  ExceptionInformation[1]=<7404548/0x70FC04>
  ExceptionInformation[2]=<3966248/0x3C8528>
5 (SVN-Rev=720) (4594) code=<0xE06D7369/EXCEPTION_CSimpleException>, ExceptionAddress=<4006870C>, NumberParameters=<3>, ExceptionFlags=<1>
  ExceptionInformation[0]=<429065504/0x19930520>
  ExceptionInformation[1]=<7404544/0x70FC00>
  ExceptionInformation[2]=<3966576/0x3C8670>
6 (SVN-Rev=720) (4594) code=<0xE06D7369/EXCEPTION_CSimpleException>, ExceptionAddress=<4006870C>, NumberParameters=<3>, ExceptionFlags=<1>
  ExceptionInformation[0]=<429065504/0x19930520>
  ExceptionInformation[1]=<7404568/0x70FC18>
  ExceptionInformation[2]=<3966312/0x3C8568>
7 (SVN-Rev=720) (4594) code=<0xE06D7369/EXCEPTION_CSimpleException>, ExceptionAddress=<4006870C>, NumberParameters=<3>, ExceptionFlags=<1>
  ExceptionInformation[0]=<429065504/0x19930520>
  ExceptionInformation[1]=<7404552/0x70FC08>
  ExceptionInformation[2]=<3966184/0x3C84E8>
8 (SVN-Rev=720) (4594) code=<0xE06D7369/EXCEPTION_CSimpleException>, ExceptionAddress=<4006870C>, NumberParameters=<3>, ExceptionFlags=<1>
  ExceptionInformation[0]=<429065504/0x19930520>
  ExceptionInformation[1]=<7404544/0x70FC00>
  ExceptionInformation[2]=<3966512/0x3C8630>
9 (SVN-Rev=720) (4594) code=<0xE06D7369/EXCEPTION_CSimpleException>, ExceptionAddress=<4006870C>, NumberParameters=<3>, ExceptionFlags=<1>
  ExceptionInformation[0]=<429065504/0x19930520>
  ExceptionInformation[1]=<7404568/0x70FC18>
  ExceptionInformation[2]=<3966380/0x3C85AC>
10 (SVN-Rev=720) (4594) code=<0xE06D7369/EXCEPTION_CSimpleException>, ExceptionAddress=<4006870C>, NumberParameters=<3>, ExceptionFlags=<1>
  ExceptionInformation[0]=<429065504/0x19930520>
  ExceptionInformation[1]=<7404548/0x70FC04>
  ExceptionInformation[2]=<3966448/0x3C85F0>
11 02.07.13 13:31:25 (SVN-Rev=720) (8178) code=<0xC0000005/EXCEPTION_ACCESS_VIOLATION>, ExceptionAddress=<00147CD8>, NumberParameters=<2>, ExceptionFlags=<0>
  ExceptionInformation[0]=<0/0x0>
  The thread attempted to read the inaccessible data.
  ExceptionInformation[1]=<4289520384/0xFFFACE300>
  The second array element specifies the virtual address of the inaccessible data.
12 02.07.13 13:31:25 (SVN-Rev=720) (6418) code=<0xC0000005/EXCEPTION_ACCESS_VIOLATION>, ExceptionAddress=<00147CD8>, NumberParameters=<2>, ExceptionFlags=<0>
  ExceptionInformation[0]=<0/0x0>
  The thread attempted to read the inaccessible data.
  ExceptionInformation[1]=<4289520128/0xFFFACE200>
  The second array element specifies the virtual address of the inaccessible data.
13 02.07.13 13:31:25 (SVN-Rev=720) (1250) code=<0xC0000005/EXCEPTION_ACCESS_VIOLATION>, ExceptionAddress=<00147CD8>, NumberParameters=<2>, ExceptionFlags=<0>
  ExceptionInformation[0]=<0/0x0>
  The thread attempted to read the inaccessible data.
  ExceptionInformation[1]=<4289519872/0xFFFACE100>
  The second array element specifies the virtual address of the inaccessible data.
1 (SVN-Rev=720) (4594) code=<0xE06D7369/EXCEPTION_CSimpleException>, ExceptionAddress=<4006870C>, NumberParameters=<3>, ExceptionFlags=<1>
  ExceptionInformation[0]=<429065504/0x19930520>
  ExceptionInformation[1]=<7404568/0x70FC18>
  ExceptionInformation[2]=<3966116/0x3C84A4>
2 (SVN-Rev=720) (4594) code=<0xE06D7369/EXCEPTION_CSimpleException>, ExceptionAddress=<4006870C>, NumberParameters=<3>, ExceptionFlags=<1>
  ExceptionInformation[0]=<429065504/0x19930520>
  ExceptionInformation[1]=<7404568/0x70FC18>
  ExceptionInformation[2]=<3965868/0x3C83AC>
3 (SVN-Rev=720) (4594) code=<0xE06D7369/EXCEPTION_CSimpleException>, ExceptionAddress=<4006870C>, NumberParameters=<3>, ExceptionFlags=<1>
  ExceptionInformation[0]=<429065504/0x19930520>
  ExceptionInformation[1]=<7404568/0x70FC18>
  ExceptionInformation[2]=<3966048/0x3C8460>
4 (SVN-Rev=720) (4594) code=<0xE06D7369/EXCEPTION_CSimpleException>, ExceptionAddress=<4006870C>, NumberParameters=<3>, ExceptionFlags=<1>
  ExceptionInformation[0]=<429065504/0x19930520>
  ExceptionInformation[1]=<7404548/0x70FC04>
  ExceptionInformation[2]=<3966248/0x3C8528>
5 (SVN-Rev=720) (4594) code=<0xE06D7369/EXCEPTION_CSimpleException>, ExceptionAddress=<4006870C>, NumberParameters=<3>, ExceptionFlags=<1>
  ExceptionInformation[0]=<429065504/0x19930520>
  ExceptionInformation[1]=<7404544/0x70FC00>
  ExceptionInformation[2]=<3966576/0x3C8670>
6 (SVN-Rev=720) (4594) code=<0xE06D7369/EXCEPTION_CSimpleException>, ExceptionAddress=<4006870C>, NumberParameters=<3>, ExceptionFlags=<1>
  ExceptionInformation[0]=<429065504/0x19930520>
  ExceptionInformation[1]=<7404568/0x70FC18>
  ExceptionInformation[2]=<3966312/0x3C8568>
7 (SVN-Rev=720) (4594) code=<0xE06D7369/EXCEPTION_CSimpleException>, ExceptionAddress=<4006870C>, NumberParameters=<3>, ExceptionFlags=<1>

```

**Figure 249: Menu Miscellaneous / Exceptions**

Data that is used internally.

## 8 Faults

### 8.1 Fault settings

#### 8.1.1 JA Fault messages

##### JA Fault messages

Access	Line	Designation	Value	Unit	Variable
D	1	Current messages	A98-8 Inval.act.key		<a href="#">actErr</a>
D	2	Accumulated msgs	M54-0 Calibr. lock		<a href="#">cumErr</a>
D	3	No. of alarms		2	<a href="#">alarmAnz</a>
D	4	No. of warnings		0	<a href="#">warnAnz</a>
D	5	No. of notes		2	<a href="#">hinweisAnz</a>
E *	6	Computer fault	As alarms ▾		<a href="#">rechnerErr</a>
B	7	Notes	As notes ▾		<a href="#">hinweis</a>
Q	8	Fault ackn. flag	0		<a href="#">errorQuit</a>
D	9	Current messages	A93-6 USZ timeout		<a href="#">actErr_2</a>
E *	11	Q=0 fault suppress.	Suppress ▾		<a href="#">quOKSMoDe</a>
B	12	Redundant GQ	As notes ▾		<a href="#">ersGBHOGE</a>
D	14	AG21 clear text	A57-8 Param.Attack		<a href="#">errKlar</a>
D	15	message counter		15	<a href="#">errChgCnt</a>
D	18	First alarm	19-09-2019 11:46:41		<a href="#">ez_alarm</a>
D	19	Last alarm	19-09-2019 11:46:41		<a href="#">lz_alarm</a>
D	20	First warning	DD-MM-YYYY hh:mm:ss		<a href="#">ez_warn</a>
D	21	Last warning	DD-MM-YYYY hh:mm:ss		<a href="#">lz_warn</a>
E *	22	Alarm contact mode	Realtime output ▾		<a href="#">alarmMod</a>
B	23	Warn contact mode	Realtime output ▾		<a href="#">warnMod</a>
B	24	Elongation time	5	s	<a href="#">elongKtk</a>
D	25	Collective msg.	00000001	hex	<a href="#">sammel</a>
Q	26	Error simulation	-1		<a href="#">simErr</a>
D	27	Time confirmation	19-09-2019 11:46:41		<a href="#">quitZeit</a>
D	28	Bits flux control	0030	hex	<a href="#">spoeth</a>
A *	29	Vm-Alarm		0	<a href="#">midVBErr</a>
D	30	Error quit contact		OFF	<a href="#">ktkEquip</a>
B	31	Src error quit ctc	OFF ▾		<a href="#">kzoEquip</a>

Enter Cancel Load defaults Refresh

**Figure 250: Menu JA Fault messages**

The coordinate **JA01 Current messages** shows all pending (active) messages in 2-second intervals. **JA02 Accumulated msgs** shows all messages since the last acknowledgment.

**JA06** defines whether computer errors are displayed as alarms or warnings. Analogously, **JA07** allows for the setting of whether notices are displayed as notices or warnings.

**JA11** (de-/) activates fault suppression for flow rate = zero ( $Q = 0 \text{ m}^3/\text{h}$ ) The coordinate **JA12** can be used to trigger the output of a warning or an indication if the preadjust-



## 8.1.2 JB Message register

### JB Message registers

Access	Line	Designation	Value	Unit	Variable
D	1	Message 0...15	0000	hex	<a href="#">errBTab01</a>
D	2	Message 16...31	0000	hex	<a href="#">errBTab02</a>
D	3	Message 32...47	0000	hex	<a href="#">errBTab03</a>
D	4	Message 48...63	0000	hex	<a href="#">errBTab04</a>
D	5	Message 64...79	0000	hex	<a href="#">errBTab05</a>
D	6	Message 80...95	0000	hex	<a href="#">errBTab06</a>
D	7	Message 96..111	0000	hex	<a href="#">errBTab07</a>
D	8	Message 112..127	0000	hex	<a href="#">errBTab08</a>
D	9	Message 128..143	0800	hex	<a href="#">errBTab09</a>
D	10	Message 144..159	0000	hex	<a href="#">errBTab10</a>
D	11	Message 160..175	0000	hex	<a href="#">errBTab11</a>
D	12	Message 176..191	0000	hex	<a href="#">errBTab12</a>
D	13	Message 192..207	0000	hex	<a href="#">errBTab13</a>
D	14	Message 208..223	0000	hex	<a href="#">errBTab14</a>
D	15	Message 224..239	0000	hex	<a href="#">errBTab15</a>
D	16	Message 240..255	0000	hex	<a href="#">errBTab16</a>
D	17	Message 256..271	0800	hex	<a href="#">errBTab17</a>
D	18	Message 272..287	0000	hex	<a href="#">errBTab18</a>
D	19	Message 288..303	0000	hex	<a href="#">errBTab19</a>
D	20	Message 304..319	0000	hex	<a href="#">errBTab20</a>
D	21	Message 320..335	0000	hex	<a href="#">errBTab21</a>
D	22	Message 336..351	0000	hex	<a href="#">errBTab22</a>
D	23	Message 352..367	0000	hex	<a href="#">errBTab23</a>
D	24	Message 368..383	0000	hex	<a href="#">errBTab24</a>
D	25	Message 384..399	0000	hex	<a href="#">errBTab25</a>
D	26	Message 400..415	0000	hex	<a href="#">errBTab26</a>
D	27	Message 416..431	0000	hex	<a href="#">errBTab27</a>
D	28	Message 432..447	0000	hex	<a href="#">errBTab28</a>
D	29	Message 448..463	0000	hex	<a href="#">errBTab29</a>
D	30	Message 464..479	0000	hex	<a href="#">errBTab30</a>
D	31	Message 480..495	0000	hex	<a href="#">errBTab31</a>
D	32	Message 496..511	0000	hex	<a href="#">errBTab32</a>
D	33	Message 512..527	0000	hex	<a href="#">errBTab33</a>
D	34	Message 528..543	0000	hex	<a href="#">errBTab34</a>
D	35	Message 544..559	0000	hex	<a href="#">errBTab35</a>
D	36	Message 560..575	0000	hex	<a href="#">errBTab36</a>
D	37	Message 576..591	0000	hex	<a href="#">errBTab37</a>
D	38	Message 592..607	0000	hex	<a href="#">errBTab38</a>
D	39	Message 608..623	0000	hex	<a href="#">errBTab39</a>
D	40	Message 624..639	0002	hex	<a href="#">errBTab40</a>
D	41	Message 640..655	0000	hex	<a href="#">errBTab41</a>
D	42	Message 656..671	0000	hex	<a href="#">errBTab42</a>
D	43	Message 672..687	0000	hex	<a href="#">errBTab43</a>
D	44	Message 688..703	0000	hex	<a href="#">errBTab44</a>
D	45	Message 704..719	0000	hex	<a href="#">errBTab45</a>
D	46	Message 720..735	0000	hex	<a href="#">errBTab46</a>
D	47	Message 736..751	0000	hex	<a href="#">errBTab47</a>
D	48	Message 752..767	0000	hex	<a href="#">errBTab48</a>
D	49	Message 768..783	0000	hex	<a href="#">errBTab49</a>
D	50	Message 784..799	0000	hex	<a href="#">errBTab50</a>
B	51	Message type	Passive	▼	<a href="#">errBTMod</a>

Figure 251: Menu JB Message register

If coordinate **JB51 Message type** is set to "passive", the error bits transmitted via Modbus remain at 1 until they are acknowledged manually.

If coordinate **JB51** is set to "active", the error bits transmitted via Modbus remain at 1 for as long as the fault is pending (this corresponds to the blinking of the LED on the front panel of the ERZ2000-NG)

Coordinates **JB01** to **JB50** show the assigned message numbers. The meaning of the messages is provided in the **Documentation** menu.

### 8.1.3 CJ GIA-Bit table

#### JC GIA-bit table

Access Line	Designation	Value	Unit	Variable
D 1	Message 0...15	0000	hex	<a href="#">rqBTab01</a>
D 2	Message 16...31	0000	hex	<a href="#">rqBTab02</a>
D 3	Message 32...47	0000	hex	<a href="#">rqBTab03</a>
D 4	Message 48...63	0000	hex	<a href="#">rqBTab04</a>
D 5	Message 64...79	0000	hex	<a href="#">rqBTab05</a>
D 6	Message 80...95	0000	hex	<a href="#">rqBTab06</a>
D 7	Message 96..111	0000	hex	<a href="#">rqBTab07</a>
D 8	Message 112..127	0002	hex	<a href="#">rqBTab08</a>
D 9	Message 128..143	0020	hex	<a href="#">rqBTab09</a>
D 10	Message 144..159	0000	hex	<a href="#">rqBTab10</a>
D 11	Message 160..175	0000	hex	<a href="#">rqBTab11</a>
D 12	Message 176..191	0000	hex	<a href="#">rqBTab12</a>
D 13	Message 192..207	0000	hex	<a href="#">rqBTab13</a>
D 14	Message 208..223	0000	hex	<a href="#">rqBTab14</a>
D 15	Message 224..239	0000	hex	<a href="#">rqBTab15</a>
D 16	Message 240..255	0000	hex	<a href="#">rqBTab16</a>
D 17	Message 256..271	0000	hex	<a href="#">rqBTab17</a>
D 18	Message 272..287	0000	hex	<a href="#">rqBTab18</a>
D 19	Message 288..303	0000	hex	<a href="#">rqBTab19</a>
D 20	Message 304..319	0000	hex	<a href="#">rqBTab20</a>

Refresh

Figure 252: Menu JC GIA bit table

### 8.1.4 JD Debugging

#### JD Debugging

Access Line	Designation	Value	Unit	Variable
B 1	Software debug	No <input type="button" value="v"/>		<a href="#">buggy</a>
D 2	Debugging code	19007		<a href="#">buqqyCode</a>
D 3	Debug.time stamp	27-09-2018 16:57:34		<a href="#">buqqyTime</a>
D 4	Debug counter	10		<a href="#">buqqyAnz</a>
D 20	C1:Modbus-teleg.	0		<a href="#">MbC1hits</a>
D 21	C2:Modbus-teleg.	0		<a href="#">MbC2hits</a>
D 22	C3:Modbus-teleg.	0		<a href="#">MbC3hits</a>
D 23	IP:Modbus-teleg.	621521		<a href="#">MbIPhits</a>
D 29	DSfG trace			<a href="#">traceDSfG</a>
D 30	DSfG nodes	0		<a href="#">nodes</a>
D 40	free RAM percent	26.074	%	<a href="#">ramfreeperc</a>
B 41	Warn limit RAM	<input type="text" value="5.000"/>	%	<a href="#">ramfreeWGwu</a>
D 42	total RAM	65114112	Bytes	<a href="#">ramTotal</a>
D 43	free RAM	16977920	Bytes	<a href="#">ramfreeAvail</a>
D 44	free RAM min.	16523264	Bytes	<a href="#">rfaMn</a>
D 45	free RAM max.	23035904	Bytes	<a href="#">rfaMx</a>
D 46	canHash	1312	Bytes	<a href="#">canHash</a>
D 47	memory DSfG	0	Bytes	<a href="#">dsfqAlloc</a>
D 48	memory HTML	0	Bytes	<a href="#">anmrkAlloc</a>
D 49	active dialogue	Messages		<a href="#">actDialog</a>
D 50	Sub: overview	System		<a href="#">subUebersi</a>
D 51	Sub: funktionen	Freeze		<a href="#">subFunktio</a>
D 52	description 1	actDialog		<a href="#">name_long_1</a>
D 53	multipurpose value 1	7		<a href="#">gp_long_1</a>
D 54	description 2	subUebersi		<a href="#">name_long_2</a>
D 55	multipurpose value 2	6		<a href="#">gp_long_2</a>
D 56	description 3	subFunktio		<a href="#">name_long_3</a>
D 57	multipurpose value 3	7		<a href="#">gp_long_3</a>
D 58	description 4			<a href="#">name_long_4</a>
D 59	multipurpose value 4	0		<a href="#">gp_long_4</a>
D 60	description 5			<a href="#">name_long_5</a>
B 61	multipurpose value 5	<input type="text" value="0"/>		<a href="#">gp_long_5</a>
D 62	description 6			<a href="#">name_long_6</a>
B 63	multipurpose value 6	<input type="text" value="0"/>		<a href="#">gp_long_6</a>
D 64	description 7			<a href="#">name_long_7</a>
B 65	multipurpose value 7	<input type="text" value="0"/>		<a href="#">gp_long_7</a>
D 66	description 8			<a href="#">name_long_8</a>
Q 67	data exchange testing	<input type="text" value="0"/>		<a href="#">pyDataExc</a>
D 68	description d 1			<a href="#">name_d_1</a>
D 69	multipurpose d 1	0.000		<a href="#">gp_double_1</a>
D 83	erzInitStat	GUI_INITIALIZED		<a href="#">erzInitStat</a>

Figure 253: Menu JD Debugging

### 8.1.5 ON Extra messages

ON Extra messages

Access Line	Designation	Value	Unit Variable
D 1	Message 1 value	OFF	<a href="#">ktkMsg1</a>
B 2	Message 1 source	OFF	<a href="#">kzoMsg1</a>
B 3	Message 1 effect	as hint	<a href="#">wrkMsg1</a>
B 4	Message 1 text	Special message test	<a href="#">bxtMsg1</a>
D 6	Message 2 value	OFF	<a href="#">ktkMsg2</a>
B 7	Message 2 source	OFF	<a href="#">kzoMsg2</a>
B 8	Message 2 effect	as hint	<a href="#">wrkMsg2</a>
B 9	Message 2 text	msg2	<a href="#">bxtMsg2</a>
D 11	Message 3 value	OFF	<a href="#">ktkMsg3</a>
B 12	Message 3 source	OFF	<a href="#">kzoMsg3</a>
B 13	Message 3 effect	as hint	<a href="#">wrkMsg3</a>
B 14	Message 3 text	msg3	<a href="#">bxtMsg3</a>
D 16	Message 4 value	OFF	<a href="#">ktkMsg4</a>
B 17	Message 4 source	OFF	<a href="#">kzoMsg4</a>
B 18	Message 4 effect	as hint	<a href="#">wrkMsg4</a>
B 19	Message 4 text	msg4	<a href="#">bxtMsg4</a>
D 21	Message 5 value	OFF	<a href="#">ktkMsg5</a>
B 22	Message 5 source	OFF	<a href="#">kzoMsg5</a>
B 23	Message 5 effect	as hint	<a href="#">wrkMsg5</a>
B 24	Message 5 text	msg5	<a href="#">bxtMsg5</a>
D 26	Message 6 value	OFF	<a href="#">ktkMsg6</a>
B 27	Message 6 source	OFF	<a href="#">kzoMsg6</a>
B 28	Message 6 effect	as hint	<a href="#">wrkMsg6</a>
B 29	Message 6 text	msg6	<a href="#">bxtMsg6</a>
D 31	Message 7 value	OFF	<a href="#">ktkMsg7</a>
B 32	Message 7 source	OFF	<a href="#">kzoMsg7</a>
B 33	Message 7 effect	as hint	<a href="#">wrkMsg7</a>
B 34	Message 7 text	msg7	<a href="#">bxtMsg7</a>
D 36	Message 8 value	OFF	<a href="#">ktkMsg8</a>
B 37	Message 8 source	OFF	<a href="#">kzoMsg8</a>
B 38	Message 8 effect	as hint	<a href="#">wrkMsg8</a>
B 39	Message 8 text	msg8	<a href="#">bxtMsg8</a>

Enter Cancel Load defaults Refresh

**Figure 254: Menu ON Extra messages**

A free contact input can be adjusted in coordinate **ON02 Message 1 source** in order to generate an application-specific message with the content of coordinate **ON04 Message 1 text** (e.g. "Special message test") independently of the contact status. In the process, it must be defined for each message whether the message is a notice, a warning or an alarm.

The message status "on" or "off" is displayed under coordinate **ON01 Message 1 value**. Whether a free contact input is available can be read and changed in **NT Contact inputs**.

## 8.2 Error table

342

Runing No.	Short text		Long text				
	Fault number	Fault category	Valence	Input enabled	No fault reported for Q = 0		
0	A	00-0	T loss	Loss of temperature	2	Yes	No
1	A	00-1	T<l.alarm lim.	Temperature below lower alarm limit	2	Yes	Yes
2	A	00-2	T>up.alarm lim.	Temperature exceeds upper alarm limit	2	Yes	Yes
3	A	00-3	T jump	Temperature gradient exceeds maximum	2	Yes	Yes
4	W	00-4	T<l.warn.lim.	Temperature below lower warning limit	2	Yes	Yes
5	W	00-5	T>up.warn.lim.	Temperature exceeds upper warning limit	2	Yes	Yes
6	H	00-9	T param.error	Inconsistent parameterization, temperature	1	No	No
7	A	01-0	TS loss	Loss of VOS temperature	2	Yes	No
8	A	01-1	TS<l.alarm lim.	VOS temperature below lower alarm limit	2	Yes	Yes
9	A	01-2	TS>up.alarm lim.	VOS temperature exceeds upper alarm limit	2	Yes	Yes
10	A	01-3	TS jump	VOS temperature gradient exceeds maximum	2	Yes	Yes
11	W	01-4	TS<l.warn.lim.	VOS temperature below lower warning limit	2	Yes	Yes
12	W	01-5	TS>up.warn.lim.	VOS temperature exceeds upper warning limit	2	Yes	Yes
13	H	01-9	TS param.error	Inconsistent parameterization, VOS temperature	1	No	No
14	A	02-0	TD loss	Loss of density transmitter temperature	2	Yes	No
15	A	02-1	TD<l.alarm lim.	Density transmitter temperature below lower alarm limit	2	Yes	Yes
16	A	02-2	TD>up.alarm lim.	Density transmitter temperature exceeds upper alarm limit	2	Yes	Yes
17	A	02-3	TD jump	Density transmitter temperature gradient exceeds maximum	2	Yes	Yes
18	W	02-4	TD<l.warn.lim.	Density transmitter temperature below lower warning limit	2	Yes	Yes
19	W	02-5	TD>up.warn.lim.	Density transmitter temperature exceeds upper warning limit	2	Yes	Yes
20	H	02-9	TD param.error	Inconsistent parameterization, density transmitter temperature	1	No	No
21	A	03-0	Pa loss	Loss of absolute pressure	2	Yes	No
22	A	03-1	Pa<l.alarm lim.	Absolute pressure below lower alarm limit	2	Yes	Yes
23	A	03-2	Pa>up.alarm lim.	Absolute pressure exceeds upper alarm limit	2	Yes	Yes
24	A	03-3	Pa jump	Absolute pressure gradient exceeds maximum	2	Yes	Yes
25	W	03-4	Pa<l.warn.lim.	Absolute pressure below lower warning limit	2	Yes	Yes
26	W	03-5	Pa>up.warn.lim.	Absolute pressure exceeds upper warning limit	2	Yes	Yes
27	H	03-9	Pa param.error	Inconsistent parameterization, absolute pressure	1	No	No
28	A	04-0	sd loss	Loss of standard density	2	Yes	No
29	A	04-1	sd<l.alarm lim.	Standard density below lower alarm limit	2	Yes	Yes
30	A	04-2	sd>up.alarm lim.	Standard density exceeds upper alarm limit	2	Yes	Yes
31	A	04-3	sd jump	Standard density gradient exceeds maximum	2	Yes	Yes
32	W	04-4	sd<l.warn.lim.	Standard density below lower warning limit	2	Yes	Yes
33	W	04-5	sd>up.warn.lim.	Standard density exceeds upper warning limit	2	Yes	Yes
34	W	04-6	Vo warning	Vo failure, effect of fault: warning	2	Yes	No
35	H	04-7	HW pulse comp.	Hardware pulse comparison has taken effect	1	Yes	Yes
36	W	04-8	Run deviation	Quantitative comparison for synchronous run has taken effect	1	Yes	No
37	H	04-9	sd param.error	Inconsistent parameterization, standard density	1	No	No
38	A	05-0	R loss	Loss of density	2	Yes	No
39	A	05-1	R<l.alarm lim.	Density below lower alarm limit	2	Yes	Yes
40	A	05-2	R>up.alarm lim.	Density exceeds upper alarm limit	2	Yes	Yes



41	A	05-3	R jump	Density gradient exceeds maximum	2	Yes	Yes
42	W	05-4	R<l.warn.lim.	Density below lower warning limit	2	Yes	Yes
43	W	05-5	R>up.warn.lim.	Density exceeds upper warning limit	2	Yes	Yes
44	A	05-6	R comp.error	Incorrect density calculation	2	Yes	Yes
45	W	05-7	Acc.puls.>max.	Too many temporarily stored pulses with open calibration lock	2	No	No
46	A	05-8	Vo alarm	Vo failure, effect of fault: alarm	2	Yes	No
47	H	05-9	R param.error	Inconsistent parameterization, density	1	No	No
48	A	06-0	Hs loss	Loss of superior calorific value	2	Yes	No
49	A	06-1	Hs<l.alarm lim.	Superior calorific value below lower alarm limit	2	Yes	Yes
50	A	06-2	Hs>up.alarm lim.	Superior calorific value exceeds upper alarm limit	2	Yes	Yes
51	A	06-3	Hs jump	Superior calorific value gradient exceeds maximum	2	Yes	Yes
52	W	06-4	Hs<l.warn.lim.	Superior calorific value below lower warning limit	2	Yes	Yes
53	W	06-5	Hs>up.warn.lim.	Superior calorific value exceeds upper warning limit	2	Yes	Yes
54	H	06-9	Hs param.error	Inconsistent parameterization, superior calorific value	1	No	No
55	A	07-0	CO2 loss	Loss of carbon dioxide	2	Yes	No
56	A	07-1	CO2<l.alarm lim.	Carbon dioxide below lower alarm limit	2	Yes	Yes
57	A	07-2	CO2>up.alarm lim.	Carbon dioxide exceeds upper alarm limit	2	Yes	Yes
58	A	07-3	CO2 jump	Carbon dioxide gradient exceeds maximum	2	Yes	Yes
59	W	07-4	CO2<l.warn.lim.	Carbon dioxide below lower warning limit	2	Yes	Yes
60	W	07-5	CO2>up.warn.lim.	Carbon dioxide exceeds upper warning limit	2	Yes	Yes
61	H	07-9	CO2 param.error	Inconsistent parameterization, carbon dioxide	1	No	No
62	A	08-0	VSM loss	Loss of VSM	2	Yes	No
63	A	08-1	VSM<l.alarm lim.	VSM below lower alarm limit	2	Yes	Yes
64	A	08-2	VSM>up.alarm lim.	VSM exceeds upper alarm limit	2	Yes	Yes
65	A	08-3	VSM jump	VSM gradient exceeds maximum	2	Yes	Yes
66	W	08-4	VSM<l.warn.lim.	VSM below lower warning limit	2	Yes	Yes
67	W	08-5	VSM>up.warn.lim.	VSM exceeds upper warning limit	2	Yes	Yes
68	H	08-9	VSM param.error	Inconsistent parameterization, VSM	1	No	No
69	A	09-0	H2 loss	Loss of hydrogen	2	Yes	No
70	A	09-1	H2<l.alarm lim.	Hydrogen below lower alarm limit	2	Yes	Yes
71	A	09-2	H2>up.alarm lim.	Hydrogen exceeds upper alarm limit	2	Yes	Yes
72	A	09-3	H2 jump	Hydrogen gradient exceeds maximum	2	Yes	Yes
73	W	09-4	H2<l.warn.lim.	Hydrogen below lower warning limit	2	Yes	Yes
74	W	09-5	H2>up.warn.lim.	Hydrogen exceeds upper warning limit	2	Yes	Yes
75	H	09-9	H2 param.error	Inconsistent parameterization, hydrogen	1	No	No
76	W	10-8	Def. channel 1	Channel 1 failed	1	No	No
77	W	10-9	Def. channel 2	Channel 2 failed	1	No	No
78	W	11-0	Start-up>max.	Meter start-up time too long	2	Yes	No
79	W	11-1	Slow-down>max.	Meter slow-down time too long	2	Yes	No
80	A	12-0	VSB loss	Loss of VSB	2	Yes	No
81	A	12-1	VSB<l.alarm lim.	VSB below lower alarm limit	2	Yes	Yes
82	A	12-2	VSB>up.alarm lim.	VSB exceeds upper alarm limit	2	Yes	Yes
83	A	12-3	VSB jump	VSB gradient exceeds maximum	2	Yes	Yes
84	W	12-4	VSB<l.warn.lim.	VSB below lower warning limit	2	Yes	Yes
85	W	12-5	VSB>up.warn.lim.	VSB exceeds upper warning limit	2	Yes	Yes
86	H	12-9	VSB param.error	Inconsistent parameterization, VSB	1	No	No
87	A	13-0	Pg loss	Loss of gauge pressure	2	Yes	No
88	A	13-1	Pg<l.alarm lim.	Gauge pressure below lower alarm limit	2	Yes	Yes
89	A	13-2	Pg>up.alarm lim.	Gauge pressure exceeds upper alarm limit	2	Yes	Yes
90	A	13-3	Pg jump	Gauge pressure gradient exceeds maximum	2	Yes	Yes

## 8 Faults

344

91	W	13-4	Pg<l.warn.lim.	Gauge pressure below lower warning limit	2	Yes	Yes
92	W	13-5	Pg>up.warn.lim.	Gauge pressure exceeds upper warning limit	2	Yes	Yes
93	H	13-9	Pg param.error	Inconsistent parameterization, gauge pressure	1	No	No
94	A	19-0	N2 loss	Loss of nitrogen	2	Yes	No
95	A	19-1	N2<l.alarm lim.	Nitrogen below lower alarm limit	2	Yes	Yes
96	A	19-2	N2>up.alarm lim.	Nitrogen exceeds upper alarm limit	2	Yes	Yes
97	A	19-3	N2 jump	Nitrogen gradient exceeds maximum	2	Yes	Yes
98	W	19-4	N2<l.warn.lim.	Nitrogen below lower warning limit	2	Yes	Yes
99	W	19-5	N2>up.warn.lim.	Nitrogen exceeds upper warning limit	2	Yes	Yes
100	H	19-9	N2 param.error	Inconsistent parameterization, nitrogen	1	No	No
101	H	30-0	Malloc error	Dynamic memory allocation error	1	No	No
102	H	31-9	CAN fault	CAN bus malfunction	2	No	No
103	H	32-0	CAN overflow	CAN bus overflow	1	No	No
104	A	32-1	BM failure	Failure of the billing-mode signal	2	Yes	Yes
105	A	32-2	CRC12 error	Official character of custody transfer GC data violated	2	No	No
106	H	32-3	GC syntax	GC communications disturbed	1	No	No
107	H	32-4	GC comm.	GC communications disturbed	1	No	No
108	H	32-5	Overheating	Device is overheated	2	No	No
109	H	32-6	Undercooling	Device is undercooled	2	No	No
110	A	32-7	V.d.Waals alarm	Van der Waals iteration is running amok	2	Yes	Yes
111	M	33-0	Bill.Mod undef.	Undefined billing mode	1	No	No
112	M	33-1	Billing mode 1	Billing mode 1	1	No	No
113	M	33-2	Billing mode 2	Billing mode 2	1	No	No
114	M	33-3	Billing mode 3	Billing mode 3	1	No	No
115	M	33-4	Billing mode 4	Billing mode 4	1	No	No
116	M	33-5	DSfG-freeze	archive entry because attention f (freeze) on DSfG	1	No	No
117	A	39-8	flow signal loss	Loss of flow proportional signal	2	No	No
118	H	40-1	old totalizer	Totalizer directly before setting of new value	1	No	No
119	H	40-2	new totalizer	Totalizer directly after setting of new value	1	No	No
120	A(R)	40-7	Rebooted	Restart performed	1	No	No
121	H	42-1	RTC defective	Real time clock is defective	2	No	No
122	A	43-2	Def.tot.	Totalizer is defective	1	No	No
123	H	45-0	I1 inp.param.	Current input 1 parameterization error	2	No	No
124	H	45-1	I2 inp.param.	Current input 2 parameterization error	2	No	No
125	H	45-2	I3 inp.param.	Current input 3 parameterization error	2	No	No
126	H	45-3	I4 inp.param.	Current input 4 parameterization error	2	No	No
127	H	45-4	I5 inp.param.	Current input 5 parameterization error	2	No	No
128	H	45-5	I6 inp.param.	Current input 6 parameterization error	2	No	No
129	H	45-6	I7 inp.param.	Current input 7 parameterization error	2	No	No
130	H	45-7	I8 inp.param.	Current input 8 parameterization error	2	No	No
131	H	45-8	PT1 inp.param.	Resistance input 1 parameterization error	2	No	No
132	H	45-9	PT2 inp.param.	Resistance input 2 parameterization error	2	No	No
133	H	46-0	Cont.param.error	Parameterization of contact input, double seizing	1	No	No
134	H	46-1	Vo defective	Vo transmitter shows unexpected behavior	2	No	No
135	H	46-2	Vo timeout	No more signal from Vo transmitter	2	No	No
136	H	46-3	Vo protocol	Vo protocol error	2	No	No
137	H	46-4	Deleted pulses	Stored pulses were deleted	1	No	No
138	H	46-5	I9 inp.param.	Current input 9 parameterization error	2	No	No
139	H	46-6	I10 inp.param.	Current input 10 parameterization error	2	No	No
140	H	46-7	I11 inp.param.	Current input 11 parameterization error	2	No	No

141	H	46-8	I12 inp.param.	Current input 12 parameterization error	2	No	No
142	W	47-0	Qm<l.warn.lim.	Flow rate at base conditions below lower warning limit	2	Yes	No
143	W	47-1	Qm>up.warn.lim.	Flow rate at measurement conditions exceeds upper warning limit	2	Yes	No
144	W	47-2	Qmc<l.warn.lim.	Corrected flow rate at measurement conditions below lower warning limit	2	Yes	No
145	W	47-3	Qmc>up.warn.lim.	Corrected flow rate at measurement conditions exceeds upper warning limit	2	Yes	No
146	W	47-4	Qb<l.warn.lim.	Volumetric flow rate at base conditions below lower warning limit	2	Yes	No
147	W	47-5	Qb>up.warn.lim.	Volumetric flow rate at base conditions exceeds upper warning limit	2	Yes	No
148	W	47-6	Qe<l.warn.lim.	Energy flow rate below lower warning limit	2	Yes	No
149	W	47-7	Qe>up.warn.lim.	Energy flow rate exceeds upper warning limit	2	Yes	No
150	W	47-8	Qms<l.warn.lim.	Mass flow rate below lower warning limit	2	Yes	No
151	W	47-9	Qms>up.warn.lim.	Mass flow rate exceeds upper warning limit	2	Yes	No
152	A	48-0	CAN timeout	CAN bus timeout	2	No	No
153	H	48-1	Def.modem	Modem is defective or switched off	1	No	No
154	M	48-2	Factory state	I am a device which has not been tested.	1	No	No
155	H	48-3	PT1 open circ.	Resistance measurement 1 shows open circuit	2	No	No
156	H	48-4	PT2 open circ.	Resistance measurement 2 shows open circuit	2	No	No
157	A	48-5	C fact.failure	Primary value for conversion factor calculation is missing	2	No	No
158	H	48-6	PT3 inp.param.	Resistance input 3 parameterization error	2	No	No
159	H	48-7	PT4 inp.param.	Resistance input 4 parameterization error	2	No	No
160	A	50-0	T<>GERG lim.	Temperature exceeds GERG limits	2	Yes	Yes
161	A	50-1	P<>GERG lim.	Pressure exceeds GERG limits	2	Yes	Yes
162	A	50-2	rd<>GERG lim.	Relative density exceeds GERG limits	2	Yes	Yes
163	A	50-3	CO2<>GERG lim.	Carbon dioxide exceeds GERG limits	2	Yes	Yes
164	A	50-4	N2<>GERG lim.	Nitrogen exceeds GERG limits	2	Yes	Yes
165	A	50-5	Hs<>GERG lim.	Superior calorific value exceeds GERG limits	2	Yes	Yes
166	A	50-6	H2<>GERG lim.	Hydrogen exceeds GERG limits	2	Yes	Yes
167	A	50-8	GERG iter.max	Maximum permissible GERG iterations exceeded	2	Yes	Yes
168	A	51-0	T<>AGA limit	Temperature exceeds AGA limits	2	Yes	Yes
169	A	51-1	P<>AGA limit	Pressure exceeds AGA limits	2	Yes	Yes
170	A	51-2	rd<>AGA limit	Relative density exceeds AGA limits	2	Yes	Yes
171	A	51-3	CO2<>AGA limit	Carbon dioxide exceeds AGA limits	2	Yes	Yes
172	A	51-4	N2<>AGA limit	Nitrogen exceeds AGA limits	2	Yes	Yes
173	A	51-5	Hs<>AGA limit	Superior calorific value exceeds AGA limits	2	Yes	Yes
174	A	51-7	AGA oth.errors	Other AGA errors	2	Yes	Yes
175	A	51-8	AGA-pi,tau	AGA interim result, pi,tau exceed limits	2	Yes	Yes
176	A	51-9	Interp.pt.probl.	Error during calculation of interpolation point	2	Yes	Yes
177	A	52-0	Q<Qmin	Flow rate at measurement conditions below minimum	2	Yes	No
178	A	52-1	Q>Qmax	Flow rate at measurement conditions exceeds maximum	2	Yes	No
179	M	52-2	Call	Carrier signal modem	1	No	No
180	M	52-3	PTB time	PTB's telephone time service time has been detected	1	No	No
181	W	52-4	Bus-ID<>12	Bus identification for remote data transmission has not exactly 12 characters	1	No	No
182	W	52-5	RDT ID<>16	Remote data transmission identification has not exactly 16 characters	1	No	No
183	A	52-6	illegal	Illegal operating mode	2	No	No
184	M	54-0	Calibr. lock	Calibration lock is open	2	No	No
185	M	54-1	User lock	User lock is open	2	No	No
186	M	54-2	Revision	Revision switch is open	2	No	No

## 8 Faults

346

187	M	54-3	Red.GQM active	Redundant gas quality measurement active	2	No	No
188	W	54-4	GQM1 failure	Gas quality measurement 1 failure	2	No	No
189	W	54-5	GQM2 failure	Gas quality measurement 2 failure	2	No	No
190	W	54-6	sd GQM1 fail.	Loss of standard density (GQM1)	2	No	No
191	W	54-7	sd GQM2 fail.	Loss of standard density (GQM2)	2	No	No
192	W	54-8	Hs GQM1 fail.	Loss of superior calorific value (GQM1)	2	No	No
193	W	54-9	Hs GQM2 fail.	Loss of superior calorific value (GQM2)	2	No	No
194	W	55-0	CO2 GQM1 fail.	Loss of carbon dioxide (GQM1)	2	No	No
195	W	55-1	CO2 GQM2 fail.	Loss of carbon dioxide (GQM2)	2	No	No
196	W	55-2	H2 GQM1 fail.	Loss of hydrogen (GQM1)	2	No	No
197	W	55-3	H2 GQM2 fail.	Loss of hydrogen (GQM2)	2	No	No
198	W	55-4	N2 GQM1 fail.	Loss of nitrogen (GQM1)	2	No	No
199	W	55-5	N2 GQM2 fail.	Loss of nitrogen (GQM2)	2	No	No
200	W	55-6	VOS<>theory	VOS deviation between measurement and theory	2	No	No
201	W	55-8	rd GQM1 fail.	Loss of relative density (GQM1)	2	No	No
202	W	55-9	rd GQM2 fail.	Loss of relative density (GQM2)	2	No	No
203	A(R)	56-0	Chan. 1 fault	Pulse counting channel 1 implausible	1	No	No
204	A(R)	56-1	Chan. 2 fault	Pulse counting channel 2 implausible	1	No	No
205	A	56-2	Tc/Tb comb.	Tc/Tb combination not permitted	1	No	No
206	H	56-3	CAN check	CAN bus plausibilization	1	No	No
207	H	56-4	Service request	Service staff urgently required	1	No	No
208	H	56-5	Old time	Time immediately before time adjustment	1	No	No
209	H	56-6	New time	Time immediately after time adjustment	1	No	No
210	A(R)	56-7	Power OFF	Supply voltage failure	1	No	No
211	A(R)	56-8	Chan. 3 fault	Pulse counting channel 3 implausible	1	No	No
212	A(R)	56-9	Chan. 4 fault	Pulse counting channel 4 implausible	1	No	No
213	H	57-0	HF param.error	Inconsistent parameterization, HF	1	No	No
214	W	58-0	Path 1 loss	Path 1 loss	1	No	No
215	W	58-1	Path 2 loss	Path 2 loss	1	No	No
216	W	58-2	Path 3 loss	Path 3 loss	1	No	No
217	W	58-3	Path 4 loss	Path 4 loss	1	No	No
218	W	58-4	Path 5 loss	Path 5 loss	1	No	No
219	W	58-5	Path 6 loss	Path 6 loss	1	No	No
220	W	58-6	Path 7 loss	Path 7 loss	1	No	No
221	W	58-7	Path 8 loss	Path 8 loss	1	No	No
222	W	60-0	Ethane<l.warn.lim.	Ethane below lower warning limit	2	Yes	Yes
223	W	60-1	Ethane>up.warn.lim.	Ethane exceeds upper warning limit	2	Yes	Yes
224	W	60-2	C3H8<l.warn.lim.	Propane below lower warning limit	2	Yes	Yes
225	W	60-3	C3H8>up.war.lim.	Propane exceeds upper warning limit	2	Yes	Yes
226	W	60-4	N-C4<l.warn.lim.	N-butane below lower warning limit	2	Yes	Yes
227	W	60-5	N-C4>up.warn.lim.	N-butane exceeds upper warning limit	2	Yes	Yes
228	W	60-6	I-C4<l.warn.lim.	I-butane below lower warning limit	2	Yes	Yes
229	W	60-7	I-C4>up.warn.lim.	I-butane exceeds upper warning limit	2	Yes	Yes
230	W	60-8	N-C5<l.warn.lim.	N-pentane below lower warning limit	2	Yes	Yes
231	W	60-9	N-C5>up.warn.lim.	N-pentane exceeds upper warning limit	2	Yes	Yes
232	W	61-0	I-C5<l.warn.lim.	I-pentane below lower warning limit	2	Yes	Yes
233	W	61-1	I-C5>up.warn.lim.	I-pentane exceeds upper warning limit	2	Yes	Yes
234	W	61-2	NeoC5<l.warn.lim.	Neo-pentane below lower warning limit	2	Yes	Yes
235	W	61-3	NeoC5>up.warn.lim.	Neo-pentane exceeds upper warning limit	2	Yes	Yes
236	W	61-4	Hexane<l.warn.lim.	Hexane below lower warning limit	2	Yes	Yes

237	W	61-5	Hexane>up.warn.lim.	Hexane exceeds upper warning limit	2	Yes	Yes
238	W	61-6	Heptane<l.warn.lim.	Heptane below lower warning limit	2	Yes	Yes
239	W	61-7	Heptane>up.war.lim.	Heptane exceeds upper warning limit	2	Yes	Yes
240	W	61-8	Octane<l.warn.lim.	Octane below lower warning limit	2	Yes	Yes
241	W	61-9	Octane>up.warn.lim.	Octane exceeds upper warning limit	2	Yes	Yes
242	W	62-0	Nonane<l.warn.lim.	Nonane below lower warning limit	2	Yes	Yes
243	W	62-1	Nonane>up.warn.lim.	Nonane exceeds upper warning limit	2	Yes	Yes
244	W	62-2	Decane<l.warn.lim.	Decane below lower warning limit	2	Yes	Yes
245	W	62-3	Decane>up.warn.lim.	Decane exceeds upper warning limit	2	Yes	Yes
246	W	62-4	H2S<l.warn.lim.	Hydrogen sulphide below lower warning limit	2	Yes	Yes
247	W	62-5	H2S>up.warn.lim.	Hydrogen sulphide exceeds upper warning limit	2	Yes	Yes
248	W	62-6	H2O<l.warn.lim.	Water below lower warning limit	2	Yes	Yes
249	W	62-7	H2O>up.warn.lim.	Water exceeds upper warning limit	2	Yes	Yes
250	W	62-8	He<l.warn.lim.	Helium below lower warning limit	2	Yes	Yes
251	W	62-9	He>up.warn.lim.	Helium exceeds upper warning limit	2	Yes	Yes
252	W	63-0	O2<l.warn.lim.	Oxygen below lower warning limit	2	Yes	Yes
253	W	63-1	O2>up.warn.lim.	Oxygen exceeds upper warning limit	2	Yes	Yes
254	W	63-2	CO<l.warn.lim.	Carbon monoxide below lower warning limit	2	Yes	Yes
255	W	63-3	CO>up.warn.lim.	Carbon monoxide exceeds upper warning limit	2	Yes	Yes
256	W	63-4	Ethene<l.warn.lim.	Ethene below lower warning limit	2	Yes	Yes
257	W	63-5	Ethene>up.warn.lim.	Ethene exceeds upper warning limit	2	Yes	Yes
258	W	63-6	C3H6<l.warn.lim.	Propene below lower warning limit	2	Yes	Yes
259	W	63-7	C3H6>up.war.lim.	Propene exceeds upper warning limit	2	Yes	Yes
260	W	63-8	Ar<l.warn.lim.	Argon below lower warning limit	2	Yes	Yes
261	W	63-9	Ar>up.warn.lim.	Argon exceeds upper warning limit	2	Yes	Yes
262	H	64-0	RMGB missing	connection lost, RMG-Bus	2	No	No
263	H	64-1	RMGB param.err.	Inconsistent parameterization, RMG-Bus	1	No	No
264	H	64-2	DSfG param.err.	Inconsistent parameterization, DSfG	1	No	No
265	H	64-3	TCP/IP fault	can't initialize TCP/IP sockets	1	No	No
266	H	64-4	buggy software	low grade software code detected	1	No	No
267	H	64-5	file system	file system unexpected behavior	1	No	No
268	H	64-6	DSfG unex. char	DSfG: unexpected characters	1	No	No
269	H	64-7	DSfG overflow	DSfG: buffer overflow	1	No	No
270	H	64-8	DSfG checksum	DSfG: checksum incorrect	1	No	No
271	H	64-9	DSfG broadcast	DSfG: checksum incorrect broadcast telegram	1	No	No
272	H	65-0	DSfG broadc ign	DSfG: broadcast telegram ignored	1	No	No
273	H	65-1	DSfG busterm.	DSfG: missing bus termination	1	No	No
274	H	65-2	Restart archive	Restart archive after cleaning	1	No	No
275	W	65-3	EAV1 failed	Extra analog value 1 first input value failed	2	No	No
276	W	65-4	EAV1<l.warn.lim.	Extra analog value 1 below lower warning limit	2	No	No
277	W	65-5	EAV1>up.warn.lim.	Extra analog value 1 exceeds upper warning limit	2	No	No
278	A	65-6	sd failure 2IV	Standard density, second input value failed	2	Yes	No
279	W	65-7	EAV1 fail. 2IV	Extra analog value 1 second input value failed	2	No	No
280	W	65-8	EAV2 failed	Extra analog value 2 first input value failed	2	No	No
281	W	65-9	EAV2<l.warn.lim.	Extra analog value 2 below lower warning limit	2	No	No
282	W	66-0	EAV2>up.warn.lim.	Extra analog value 2 exceeds upper warning limit	2	No	No
283	W	66-1	EAV2 fail. 2IV	Extra analog value 2 second input value failed	2	No	No
284	W	66-2	EAV3 failed	Extra analog value 3 first input value failed	2	No	No
285	W	66-3	EAV3<l.warn.lim.	Extra analog value 3 below lower warning limit	2	No	No
286	W	66-4	EAV3>up.warn.lim.	Extra analog value 3 exceeds upper warning limit	2	No	No

## 8 Faults

348

287	W	66-5	EAV3 fail. 2IV	Extra analog value 3 second input value failed	2	No	No
288	W	66-6	EAV4 failed	Extra analog value 4 first input value failed	2	No	No
289	W	66-7	EAV4<l.warn.lim.	Extra analog value 4 below lower warning limit	2	No	No
290	W	66-8	EAV4>up.warn.lim.	Extra analog value 4 exceeds upper warning limit	2	No	No
291	W	66-9	EAV4 fail. 2IV	Extra analog value 4 second input value failed	2	No	No
292	W	67-0	EAV5 failed	Extra analog value 5 first input value failed	2	No	No
293	W	67-1	EAV5<l.warn.lim.	Extra analog value 5 below lower warning limit	2	No	No
294	W	67-2	EAV5>up.warn.lim.	Extra analog value 5 exceeds upper warning limit	2	No	No
295	W	67-3	EAV5 fail. 2IV	Extra analog value 5 second input value failed	2	No	No
296	W	67-4	EAV6 failed	Extra analog value 6 first input value failed	2	No	No
297	W	67-5	EAV6<l.warn.lim.	Extra analog value 6 below lower warning limit	2	No	No
298	W	67-6	EAV6>up.warn.lim.	Extra analog value 6 exceeds upper warning limit	2	No	No
299	W	67-7	EAV6 fail. 2IV	Extra analog value 6 second input value failed	2	No	No
300	W	67-8	EAV7 failed	Extra analog value 7 first input value failed	2	No	No
301	W	67-9	EAV7<l.warn.lim.	Extra analog value 7 below lower warning limit	2	No	No
302	W	68-0	EAV7>up.warn.lim.	Extra analog value 7 exceeds upper warning limit	2	No	No
303	W	68-1	EAV7 fail. 2IV	Extra analog value 7 second input value failed	2	No	No
304	W	68-2	EAV8 failed	Extra analog value 8 first input value failed	2	No	No
305	W	68-3	EAV8<l.warn.lim.	Extra analog value 8 below lower warning limit	2	No	No
306	W	68-4	EAV8>up.warn.lim.	Extra analog value 8 exceeds upper warning limit	2	No	No
307	W	68-5	EAV8 fail. 2IV	Extra analog value 8 second input value failed	2	No	No
308	W	70-0	Pulse 1 >max	Pulse output 1 overflow	2	Yes	No
309	W	70-1	Pulse 2 >max	Pulse output 2 overflow	2	Yes	No
310	W	70-2	Pulse 3 >max	Pulse output 3 overflow	2	Yes	No
311	W	70-3	Pulse 4 >max	Pulse output 4 overflow	2	Yes	No
312	W	70-6	I1 outp.<min	Current output 1 below minimum	2	Yes	No
313	W	70-7	I2 outp.<min	Current output 2 below minimum	2	Yes	No
314	W	70-8	I3 outp.<min	Current output 3 below minimum	2	Yes	No
315	W	70-9	I4 outp.<min	Current output 4 below minimum	2	Yes	No
316	W	71-0	I1 outp.>max	Current output 1 exceeds maximum	2	Yes	No
317	W	71-1	I2 outp.>max	Current output 2 exceeds maximum	2	Yes	No
318	W	71-2	I3 outp.>max	Current output 3 exceeds maximum	2	Yes	No
319	W	71-3	I4 outp.>max	Current output 4 exceeds maximum	2	Yes	No
320	A(R)	71-4	NMA ADC	Namur module A analog/digital-converter	1	No	No
321	A(R)	71-5	NMA overload	Namur module A overload	1	No	No
322	A(R)	71-6	NMA OC PT100	Namur module A open circuit PT100	1	No	No
323	A(R)	71-7	NMA OC mainch.	Namur module A open circuit main channel	1	No	No
324	A(R)	71-8	NMA OC ref.ch.	Namur module A open circuit reference channel	1	No	No
325	A(R)	71-9	NMA OC ENCO	Namur module A open circuit ENCO	1	No	No
326	A(R)	72-0	NMB ADC	Namur module B analog/digital-converter	1	No	No
327	A(R)	72-1	NMB overload	Namur module B overload	1	No	No
328	A(R)	72-2	NMB OC PT100	Namur module B open circuit PT100	1	No	No
329	A(R)	72-3	NMB OC Messk.	Namur module B open circuit main channel	1	No	No
330	A(R)	72-4	NMB OC Vgl.k.	Namur module B open circuit reference channel	1	No	No
331	A(R)	72-5	NMB OC ENCO	Namur module B open circuit ENCO	1	No	No
332	H	73-0	I1 outp.param.	Current output 1 parameterization error	1	No	No
333	H	73-1	I2 outp.param.	Current output 2 parameterization error	1	No	No
334	H	73-2	I3 outp.param.	Current output 3 parameterization error	1	No	No
335	H	73-3	I4 outp.param.	Current output 4 parameterization error	1	No	No
336	H	74-0	K1 outp.param.	Contact output 1 parameterization error	1	No	No

337	H	74-1	K2 outp.param.	Contact output 2 parameterization error	1	No	No
338	H	74-2	K3 outp.param.	Contact output 3 parameterization error	1	No	No
339	H	74-3	K4 outp.param.	Contact output 4 parameterization error	1	No	No
340	H	74-4	K5 outp.param.	Contact output 5 parameterization error	1	No	No
341	H	74-5	K6 outp.param.	Contact output 6 parameterization error	1	No	No
342	H	74-6	K7 outp.param.	Contact output 7 parameterization error	1	No	No
343	H	74-7	K8 outp.param.	Contact output 8 parameterization error	1	No	No
344	W	75-0	t>Sd corr.time	Sd calibration time exceeded	2	Yes	No
345	W	75-1	Sd corr signal	Sd input signal fault, calibration unit	2	Yes	No
346	W	75-2	Sd corr>perm.(W)	Sd correction value out of permitted range	2	Yes	No
347	W	75-3	t>Hs corr.time	Hs calibration time exceeded	2	Yes	No
348	W	75-4	Hscorr signal	Hs input signal fault, calibration unit	2	Yes	No
349	W	75-5	Hscorr>perm.(W)	Hs correction value formation out of permitted range	2	Yes	No
350	H	76-0	Mod. 1A false	Module 1A assembly implausible	2	No	No
351	H	76-1	Mod. 1B false	Module 1B assembly implausible	2	No	No
352	H	76-2	Mod. 2A false	Module 2A assembly implausible	2	No	No
353	H	76-3	Mod. 2B false	Module 2B assembly implausible	2	No	No
354	H	76-4	Mod. 3A false	Module 3A assembly implausible	2	No	No
355	H	76-5	Mod. 3B false	Module 3B assembly implausible	2	No	No
356	A	77-0	DP1 (I<3mA)	delta-P cell 1 current lower 3 mA	2	No	No
357	A	77-1	DP2 (I<3mA)	delta-P cell 2 current lower 3 mA	2	No	No
358	A	77-2	DP3 (I<3mA)	delta-P cell 3 current lower 3 mA	2	No	No
359	A	77-3	Beta illegal	illegal diameter ratio orifice/pipe	2	No	No
360	A	77-4	DP1 failure	delta-P cell 1 failure	2	No	No
361	A	77-5	DP2 failure	delta-P cell 2 failure	2	No	No
362	A	77-6	DP3 failure	delta-P cell 3 failure	2	No	No
363	A	77-7	DP>max.	delta-P bigger maximum	2	No	No
364	H	77-8	DP's incoherent	delta-P team play of cells is not harmonious	2	No	Yes
365	H	77-9	HART-Corr>max.	Maximum permitted HART-Correction out of range	2	No	No
366	H	78-0	DP1-Corr denied	Zero point correction for DP1 not accepted	1	No	No
367	H	78-1	G486 violated	DVGW G486 (1/3-rule) violated. Gas is incompatible with GERG	2	No	Yes
368	A	78-2	GQM-list	GQM-list is fault	2	No	No
369	A	78-3	Main GQ unknown	Main gas quality unknown identification	2	No	No
370	A	78-4	Ref GQ unknown	Reference gas quality unknown identification	2	No	No
371	A	78-5	Main GQ CRC12	Main gas quality CRC12 implausible	2	No	No
372	A	78-6	Ref GQ CRC12	Reference Gas Quality CRC12 implausible	2	No	No
373	W	78-7	flow in close	Flow in closed pipe	2	No	No
374	W	78-8	FC-BIOS old	Flow computer bios version is to old	1	No	No
375	H	78-9	HART1 status	HART 1 status reports trouble	1	No	No
376	H	79-0	HART2 status	HART 2 status reports trouble	1	No	No
377	H	79-1	HART3 status	HART 3 status reports trouble	1	No	No
378	H	79-2	HART4 status	HART 4 status reports trouble	1	No	No
379	H	79-3	HART5 status	HART 5 status reports trouble	1	No	No
380	H	79-4	HART6 status	HART 6 status reports trouble	1	No	No
381	H	79-5	HART9 status	HART 9 status reports trouble	1	No	No
382	H	79-6	HART10 status	HART 10 status reports trouble	1	No	No
383	H	79-7	HART11 status	HART 11 status reports trouble	1	No	No
384	H	79-8	HART12 status	HART 12 status reports trouble	1	No	No
385	A	80-0	dkvk>max.	Maximum deviation at operating point exceeded	2	Yes	No
386	A	80-1	IGM SV invalid	IGM invalid substitute value used	2	No	Yes

## 8 Faults

350

387	A	80-2	Path failure >max	Number of path failure's greater than allowed	2	No	No
388	H	80-3	AGA8<>range	AGA8 range violation	2	No	No
389	A	80-4	Eta loss	Loss of viscosity	2	Yes	No
390	A	80-5	Eta<l.alarm lim.	Viscosity below lower alarm limit	2	Yes	Yes
391	A	80-6	Eta>up.alarm lim.	Viscosity exceeds upper alarm limit	2	Yes	Yes
392	W	80-7	Eta<l.warn.lim.	Viscosity below lower warning limit	2	Yes	Yes
393	W	80-8	Eta>up.warn.lim.	Viscosity exceeds upper warning limit	2	Yes	Yes
394	H	80-9	Eta param.error	Inconsistent parameterization, viscosity	1	No	No
395	A	81-0	Eta jump	Viscosity gradient exceeds maximum	2	Yes	Yes
396	W	81-1	Path 1 measure	Path 1 measurement quality less as demanded	2	No	Yes
397	W	81-2	Path 2 measure	Path 2 measurement quality less as demanded	2	No	Yes
398	W	81-3	Path 3 measure	Path 3 measurement quality less as demanded	2	No	Yes
399	W	81-4	Path 4 measure	Path 4 measurement quality less as demanded	2	No	Yes
400	W	81-5	Path 5 measure	Path 5 measurement quality less as demanded	2	No	Yes
401	W	81-6	Path 6 measure	Path 6 measurement quality less as demanded	2	No	Yes
402	W	81-7	Path 7 measure	Path 7 measurement quality less as demanded	2	No	Yes
403	W	81-8	Path 8 measure	Path 8 measurement quality less as demanded	2	No	Yes
404	W	81-9	Path 1 comm.	Path 1 communication quality less as demanded	2	No	Yes
405	W	82-0	Path 2 comm.	Path 2 communication quality less as demanded	2	No	Yes
406	W	82-1	Path 3 comm.	Path 3 communication quality less as demanded	2	No	Yes
407	W	82-2	Path 4 comm.	Path 4 communication quality less as demanded	2	No	Yes
408	W	82-3	Path 5 comm.	Path 5 communication quality less as demanded	2	No	Yes
409	W	82-4	Path 6 comm.	Path 6 communication quality less as demanded	2	No	Yes
410	W	82-5	Path 7 comm.	Path 7 communication quality less as demanded	2	No	Yes
411	W	82-6	Path 8 comm.	Path 8 communication quality less as demanded	2	No	Yes
412	H	82-7	Path 1 VOS	Path 1 VOS implausible	2	No	Yes
413	H	82-8	Path 2 VOS	Path 2 VOS implausible	2	No	Yes
414	H	82-9	Path 3 VOS	Path 3 VOS implausible	2	No	Yes
415	H	83-0	Path 4 VOS	Path 4 VOS implausible	2	No	Yes
416	H	83-1	Path 5 VOS	Path 5 VOS implausible	2	No	Yes
417	H	83-2	Path 6 VOS	Path 6 VOS implausible	2	No	Yes
418	H	83-3	Path 7 VOS	Path 7 VOS implausible	2	No	Yes
419	H	83-4	Path 8 VOS	Path 8 VOS implausible	2	No	Yes
420	H	83-5	GQM uncomplete	Main/Reference-GQM via Modbus is uncomplete	2	No	Yes
421	A	83-6	HFX miss.pulses	Counter main channel (HFX) malfunction	2	No	No
422	A	83-7	HFY miss.pulses	Counter reference channel (HFY) malfunction	2	No	No
423	A	84-0	Kpp loss	Loss of isentropic coefficient	2	Yes	No
424	A	84-1	Kpp<l.alarm lim.	Isentropic coefficient below lower alarm limit	2	Yes	Yes
425	A	84-2	Kpp>up.alarm lim.	Isentropic coefficient exceeds upper alarm limit	2	Yes	Yes
426	W	84-3	Kpp<l.warn.lim.	Isentropic coefficient below lower warning limit	2	Yes	Yes
427	W	84-4	Kpp>up.warn.lim.	Isentropic coefficient exceeds upper warning limit	2	Yes	Yes
428	H	84-5	Kpp param.error	Inconsistent parameterization, isentropic coefficient	1	No	No
429	A	84-6	Kpp jump	Isentropic coefficient gradient exceeds maximum	2	Yes	Yes
430	H	85-0	Sondermeldung1 Otto	Extra hint 1 with changeable short text	2	No	No
431	H	85-1	msg2	Extra hint 2 with changeable short text	2	No	No
432	H	85-2	msg3	Extra hint 3 with changeable short text	2	No	No
433	H	85-3	msg4	Extra hint 4 with changeable short text	2	No	No
434	H	85-4	msg5	Extra hint 5 with changeable short text	2	No	No
435	H	85-5	msg6	Extra hint 6 with changeable short text	2	No	No
436	H	85-6	msg7	Extra hint 7 with changeable short text	2	No	No



437	H	85-7	msg8	Extra hint 8 with changeable short text	2	No	No
438	W	86-0	Special message test	Extra warning 1 with changeable short text	2	No	No
439	W	86-1	msg2	Extra warning 2 with changeable short text	2	No	No
440	W	86-2	msg3	Extra warning 3 with changeable short text	2	No	No
441	W	86-3	msg4	Extra warning 4 with changeable short text	2	No	No
442	W	86-4	msg5	Extra warning 5 with changeable short text	2	No	No
443	W	86-5	msg6	Extra warning 6 with changeable short text	2	No	No
444	W	86-6	msg7	Extra warning 7 with changeable short text	2	No	No
445	W	86-7	msg8	Extra warning 8 with changeable short text	2	No	No
446	A	87-0	Special message test	Extra alarm 1 with changeable short text	2	No	No
447	A	87-1	msg2	Extra alarm 2 with changeable short text	2	No	No
448	A	87-2	msg3	Extra alarm 3 with changeable short text	2	No	No
449	A	87-3	msg4	Extra alarm 4 with changeable short text	2	No	No
450	A	87-4	msg5	Extra alarm 5 with changeable short text	2	No	No
451	A	87-5	msg6	Extra alarm 6 with changeable short text	2	No	No
452	A	87-6	msg7	Extra alarm 7 with changeable short text	2	No	No
453	A	87-7	msg8	Extra alarm 8 with changeable short text	2	No	No
454	H	88-0	param.ignored	Parameterization ignored	1	No	No
455	H	88-1	LCD-Type/Speech	Language setting not possible with this LCD-type	1	No	No
456	A	89-0	JTC loss	Loss of Joule-Thomson coefficient	2	Yes	No
457	A	89-1	JTC<l.alarm lim.	Joule-Thomson coefficient below lower alarm limit	2	Yes	Yes
458	A	89-2	JTC>up.alarm lim.	Joule-Thomson coefficient exceeds upper alarm limit	2	Yes	Yes
459	W	89-3	JTC<l.warn.lim.	Joule-Thomson coefficient below lower warning limit	2	Yes	Yes
460	W	89-4	JTC>up.warn.lim.	Joule-Thomson coefficient exceeds upper warning limit	2	Yes	Yes
461	H	89-5	JTC param.error	Inconsistent parameterization, Joule-Thomson coefficient	1	No	No
462	A	89-6	JTC jump	Joule-Thomson coefficient gradient exceeds maximum	2	Yes	Yes
463	A	89-7	flow in close	Flow in closed pipe	2	No	No
464	H	89-8	HART-Ver. old	Software version HART-card is to old	1	No	No
465	H	89-9	EXI-Ver. old	Software version EXI-card is to old	1	No	No
466	A(R)	90-0	F1 failure	Frequency measurement 1 failed	2	No	No
467	A(R)	90-1	F2 failure	Frequency measurement 2 failed	2	No	No
468	A(R)	90-2	F3 failure	Frequency measurement 3 failed	2	No	No
469	A(R)	90-3	F4 failure	Frequency measurement 4 failed	2	No	No
470	A(R)	90-4	F5 failure	Frequency measurement 5 failed	2	No	No
471	A(R)	90-5	F6 failure	Frequency measurement 6 failed	2	No	No
472	A(R)	90-6	F7 failure	Frequency measurement 7 failed	2	No	No
473	A(R)	90-7	F8 failure	Frequency measurement 8 failed	2	No	No
474	A(R)	91-0	I1 failure	Current measurement 1 failed	2	No	No
475	A(R)	91-1	I2 failure	Current measurement 2 failed	2	No	No
476	A(R)	91-2	I3 failure	Current measurement 3 failed	2	No	No
477	A(R)	91-3	I4 failure	Current measurement 4 failed	2	No	No
478	A(R)	91-4	I5 failure	Current measurement 5 failed	2	No	No
479	A(R)	91-5	I6 failure	Current measurement 6 failed	2	No	No
480	A(R)	91-6	I7 failure	Current measurement 7 failed	2	No	No
481	A(R)	91-7	I8 failure	Current measurement 8 failed	2	No	No
482	A	91-8	GC components	GC components for complete analysis are bad	2	No	No
483	A(R)	92-0	PT1 failure	Resistance measurement 1 failed	2	No	No
484	A(R)	92-1	PT2 failure	Resistance measurement 2 failed	2	No	No
485	A(R)	92-2	HART1 failure	HART 1 input failed	2	No	No
486	A(R)	92-3	HART2 failure	HART 2 input failed	2	No	No

## 8 Faults

352

487	A(R)	92-4	HART3 failure	HART 3 input failed	2	No	No
488	A(R)	92-5	HART4 failure	HART 4 input failed	2	No	No
489	A(R)	92-6	HART5 failure	HART 5 input failed	2	No	No
490	A(R)	92-7	HART6 failure	HART 6 input failed	2	No	No
491	A(R)	92-8	Corrupt param.	corrupted parameter detected	1	No	No
492	A(R)	93-0	Def.cont.inp.	Contact input failed	2	No	No
493	H	93-1	Hscorr>perm.(N)	Ongoing Hs correction value formation out of permitted range	2	Yes	No
494	H	93-2	Sd corr>perm.(N)	Ongoing Sd correction value formation out of permitted range	2	Yes	No
495	H	93-3	Function test	A function test is running at the moment	2	No	No
496	H	93-4	USZ implaus.	USZ transmitter, implausible protocol data	2	No	No
497	A	93-5	USZ alarm	USZ transmitter signalizes an alarm	2	No	No
498	A	93-6	USZ timeout	No more signal from USZ transmitter	2	No	No
499	H	93-7	Vo1 implaus.	USZ totalizer for Vo1 shows implausible behavior	1	No	No
500	H	93-8	Vo2 implaus.	USZ totalizer for Vo2 shows implausible behavior	1	No	No
501	H	93-9	Vo1D implaus.	USZ totalizer for Vo1D shows implausible behavior	1	No	No
502	H	94-0	Vo2D implaus.	USZ totalizer for Vo2D shows implausible behavior	1	No	No
503	H	94-1	Time sync.para.	Parameterization of time synchronization implausible	2	No	No
504	A(R)	94-2	I9 failure	Current measurement 9 failed	2	No	No
505	A(R)	94-3	I10 failure	Current measurement 10 failed	2	No	No
506	A(R)	94-4	I11 failure	Current measurement 11 failed	2	No	No
507	A(R)	94-5	I12 failure	Current measurement 12 failed	2	No	No
508	A(R)	94-6	PT3 failure	Resistance measurement 3 failed	2	No	No
509	A(R)	94-7	PT4 failure	Resistance measurement 4 failed	2	No	No
510	A(R)	95-0	Math.problem	Mathematical error	1	Yes	No
511	A	95-1	Corrupt code	corrupt code detected	1	No	No
512	A	95-2	Alarm volume	hard-wired contact of volume transmitter shows alarm	2	No	No
513	W	95-3	Warning volume	hard-wired contact of volume transmitter shows warning	2	No	No
514	W	95-4	Time sync fail	Time synchronization failed	1	No	No
515	H	95-5	Net time error	Net time error	1	No	No
516	A(R)	95-6	HART9 failure	HART 9 input failed	2	No	No
517	A(R)	95-7	HART10 failure	HART 10 input failed	2	No	No
518	A(R)	95-8	HART11 failure	HART 11 input failed	2	No	No
519	A(R)	95-9	HART12 failure	HART 12 input failed	2	No	No
520	A	96-0	rd loss	Loss of relative density	2	Yes	No
521	A	96-1	rd<l.alarm lim.	Relative density below lower alarm limit	2	Yes	Yes
522	A	96-2	rd>up.alarm lim.	Relative density exceeds upper alarm limit	2	Yes	Yes
523	A	96-3	rd jump	Relative density gradient exceeds maximum	2	Yes	Yes
524	W	96-4	rd<l.warn.lim.	Relative density below lower warning limit	2	Yes	Yes
525	W	96-5	rd>up.warn.lim.	Relative density exceeds upper warning limit	2	Yes	Yes
526	H	96-6	rd param.error	Inconsistent parameterization, relative density	1	No	No
527	A	96-7	Hs GC timeout	No more signal from the superior calorific value transmitter	2	Yes	No
528	A	96-8	sd GC timeout	No more signal from standard density transmitter	2	Yes	No
529	A	96-9	rd GC timeout	No more signal from relative density transmitter	2	Yes	No
530	A	97-0	CO2 GC timeout	No more signal from CO2 transmitter	2	Yes	No
531	A	97-1	N2 GC timeout	No more signal from N2 transmitter	2	Yes	No
532	A	97-2	H2 GC timeout	No more signal from H2 transmitter	2	Yes	No
533	A	97-3	Hs GC alarm	GC reports loss of superior calorific value	2	Yes	No
534	A	97-4	sd GC alarm	GC reports loss of standard density	2	Yes	No
535	A	97-5	rd GC alarm	GC reports loss of relative density	2	Yes	No
536	A	97-6	CO2 GC alarm	GC reports loss of carbon dioxide	2	Yes	No

537	A	97-7	N2 GC alarm	GC reports loss of nitrogen	2	Yes	No
538	A	97-8	H2 GC alarm	GC reports loss of hydrogen	2	Yes	No
539	A	97-9	Beattie alarm	Beattie&Bridgeman iteration is running amok	2	Yes	Yes
540	W	98-4	CH4<l.warn.lim.	Methane below lower warning limit	2	Yes	Yes
541	W	98-5	CH4>up.warn.lim.	Methane exceeds upper warning limit	2	Yes	Yes
542	A	98-7	Comp.normaliz.	Error occurred during normalization of gas components	2	Yes	Yes
543	A	98-8	Inval.act.key	Invalid activation key	2	No	No
544	H	99-1	TCP after boot	Changed TCP configuration: restart is necessary	1	No	No
545	H	99-4	Adjusted float	Floating point parameter adjusted to floating-point notation	1	No	No
546	A	99-5	VOS corr.error	Error during VOS correction calculation	2	Yes	No
547	W	99-6	C fac.comp.	Conversion factor is not plausible	2	Yes	No
548	A	99-7	AGA8 alarm	AGA 8 algorithmic error	2	Yes	Yes
549	A	99-8	AGA892DC alarm	AGA 8 92DC algorithmic error	2	Yes	Yes
550	W	99-9	Comp.<>AGA 8	Components exceed AGA limits	2	Yes	Yes
551	H	59-0	T<>T-tandem	T maximum permitted deviation to tandem partner out of range	1	Yes	Yes
552	H	59-1	P<>P-tandem	P maximum permitted deviation to tandem partner out of range	1	Yes	Yes
553	H	59-2	Vb<>Vb-Tandem	Vb maximum permitted deviation to tandem partner out of range	1	Yes	Yes
554	H	59-3	Vm<>Vm-Tandem	Vm maximum permitted deviation to tandem partner out of range	1	Yes	Yes
555	H	59-4	DP2-Corr denied	Zero point correction for DP2 not accepted	1	No	No
556	H	59-5	DP3-Corr denied	Zero point correction for DP3 not accepted	1	No	No
557	W	88-2	Signature error	Problems with signature	1	No	No
558	W	88-3	2.std.cnd.illegl	Illegal use of second base conditions (not AGA8DC92)	1	No	No
559	H	59-6	C6+ distribution	Illegal weights for C6+ distribution	2	No	No
560	H	57-1	Qu param.	Parameter inconsistent flow	2	No	No
561	W	57-2	Memory RAM	less RAM	2	No	No
562	W	57-3	Memory SDCard	less memory on SD-Card	2	No	No
563	H	57-4	http parameter	http strange parameter (Port != 80)	1	No	No
564	H	57-5	MAC ETH2	Reboot required, Eth2 MAC has changed	2	No	No
565	M	57-6	Custody commis.	custody commissioning triggered	2	No	No
566	A	57-7	CRC WinCE	WinCE-Kernel wrong CRC	2	No	No
567	A	57-8	Param.Attack	Parameter file was attacked	1	No	No
568	W	57-9	FilesysWarn	noncritical WinCE file system error	1	No	No
569	A	58-8	FilesysAlarm	critical WinCE file system error	1	No	No
570	H	58-9	Service mode	Service mode is active	1	No	No
571	A	53-0	Orifice iter>mx	Iterations orifice exceeded	1	No	No
572	H	40-3	C6 conflict	Serial interface C6 protocol in conflict	2	No	No
573	H	40-4	C7 conflict	Serial interface C7 protocol in conflict	2	No	No
574	W	34-0	Ho<>Ho-ISO6976	Calorific value no match with ISO6976	2	No	No
575	W	34-1	Rn<>Rn-ISO6976	Standard density no match with ISO6976	2	No	No
576	A	10-0	Pulse comp. 1:1	Pulse comparison fault 1:1 (main and reference channel frequencies are equal)	1	Yes	Yes
577	A	10-1	Pulse comp. X:Y	Pulse comparison fault X:Y (main and reference channel frequencies are different)	1	Yes	Yes

# Configuration

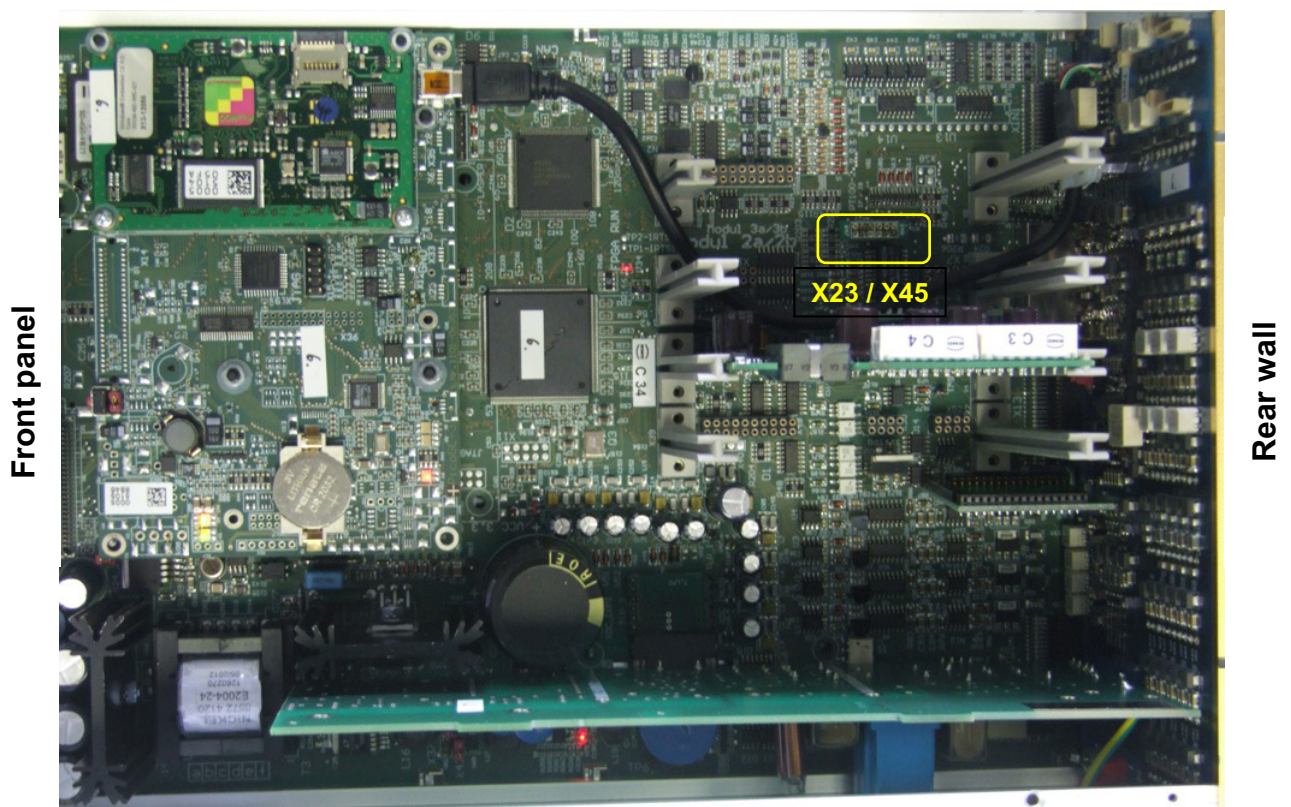
## A.1 Second PT100

### Note

A second resistance input is available as an alternative to current outputs 7 and 8!

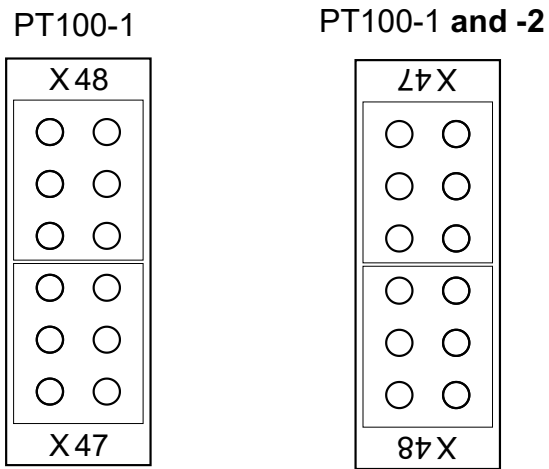
### Installation

- Remove the housing cover.
- The hardware, the base circuit board, must be configured with **Strips X23 / X45** (in *Figure 255: ERZ2000-NG printed circuit board left rear* in the device, between module slot 1 and 2).



**Figure 255: ERZ2000-NG printed circuit board**

- Install **soldering bridge circuit board** with the correct orientation. The text for a second PT 100 must be on the head when viewing the soldering bridge circuit board from the front panel.



- **PT100 connection:**

PT100-1: **X5** – 7, 8, 9, 10  
 PT100-2: **X6** – 7, 8, 9, 10

- **Measurement parameterization:**

**EI Configuration**

S	1	No.resist.meas.ch.	2	<a href="#">rNumber</a>
---	---	--------------------	---	-------------------------

## A.2 Special case of revision with orifice flow meter

If the coordinate **ED01 Revision mode** is switched from "Operation" to "Revision" in menu **E Mode**, submenu **ED Access**, it is possible to follow the measurement values of the pressure cells during the check of the individual delta-p cells in **GZ Orifice function key**. The corresponding current inputs of the cells are displayed in menu **AP diff.pressure**.

Therefore, during the check of a delta-p cell, the entire range can be monitored from 0 to max. value.

**There are 2 revision modes:**

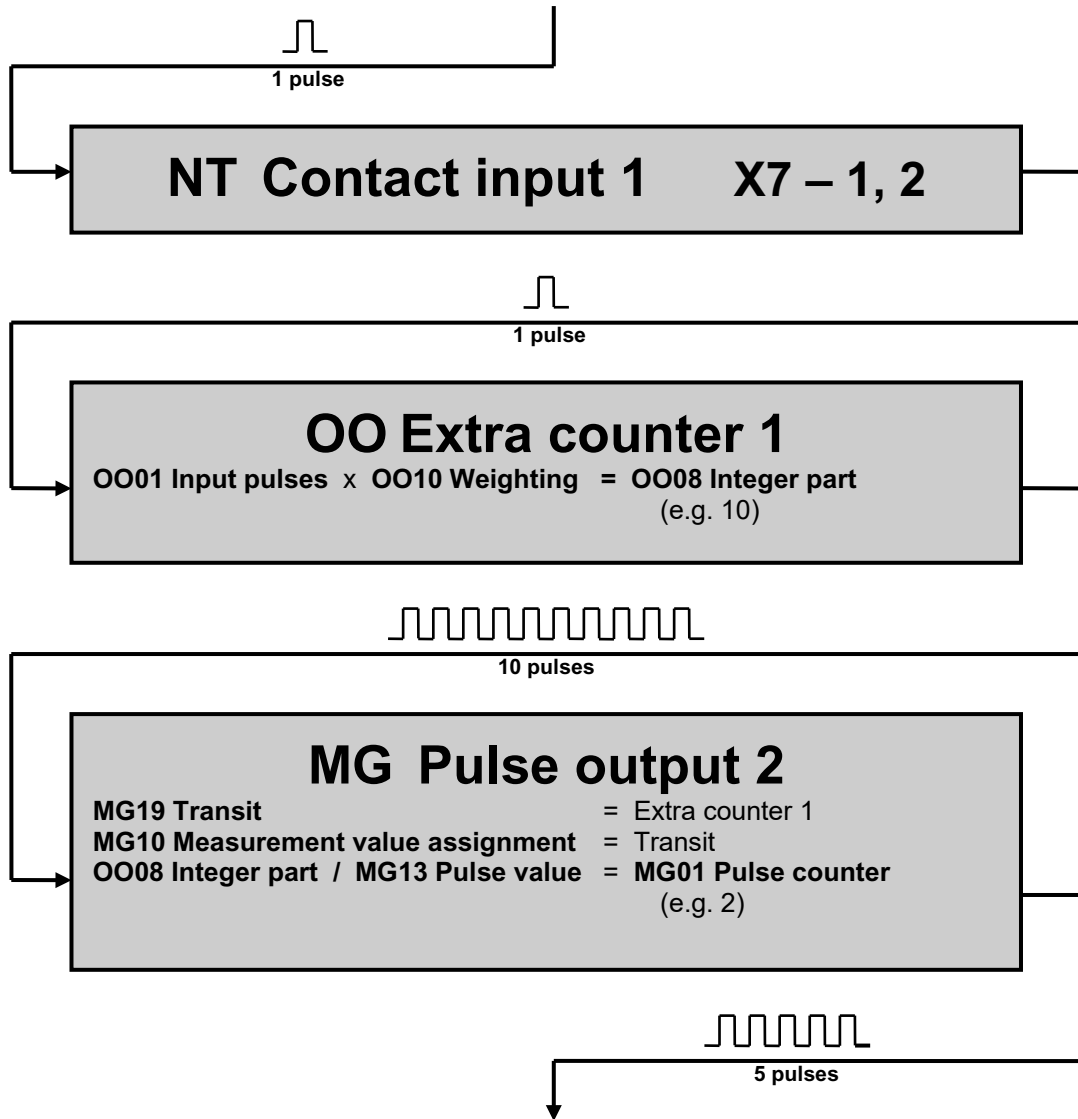
"Revision"	Standard function, activated by menu. To be used for tests with series connection. Totalizers run and are identified in the archive. Output pulses are stopped
"Revision via contact"	Standard function, activated by external contact. To be used for tests with series connection. Totalizers run and are identified in the archive. Output pulses are stopped. The contact input to be used can be selected as access to the parameter in <b>ED12 Source revision etc.</b>

Coordinates **ED13 total. in revision**, **ED14 Temp. at revision** and **ED15 Pressure at revision** define the behavior of the ERZ2000-NG during the revision:

If the totalizers stop during the revision, "At rest" must be selected in **ED13**. If pressure or temperature should remain at the last valid temperature during a revision, "retained value" must be selected in **ED14** and **ED15**.

### A.3 Linking extra counter with pulse output

Example: Extra counter 1 with pulse output 2

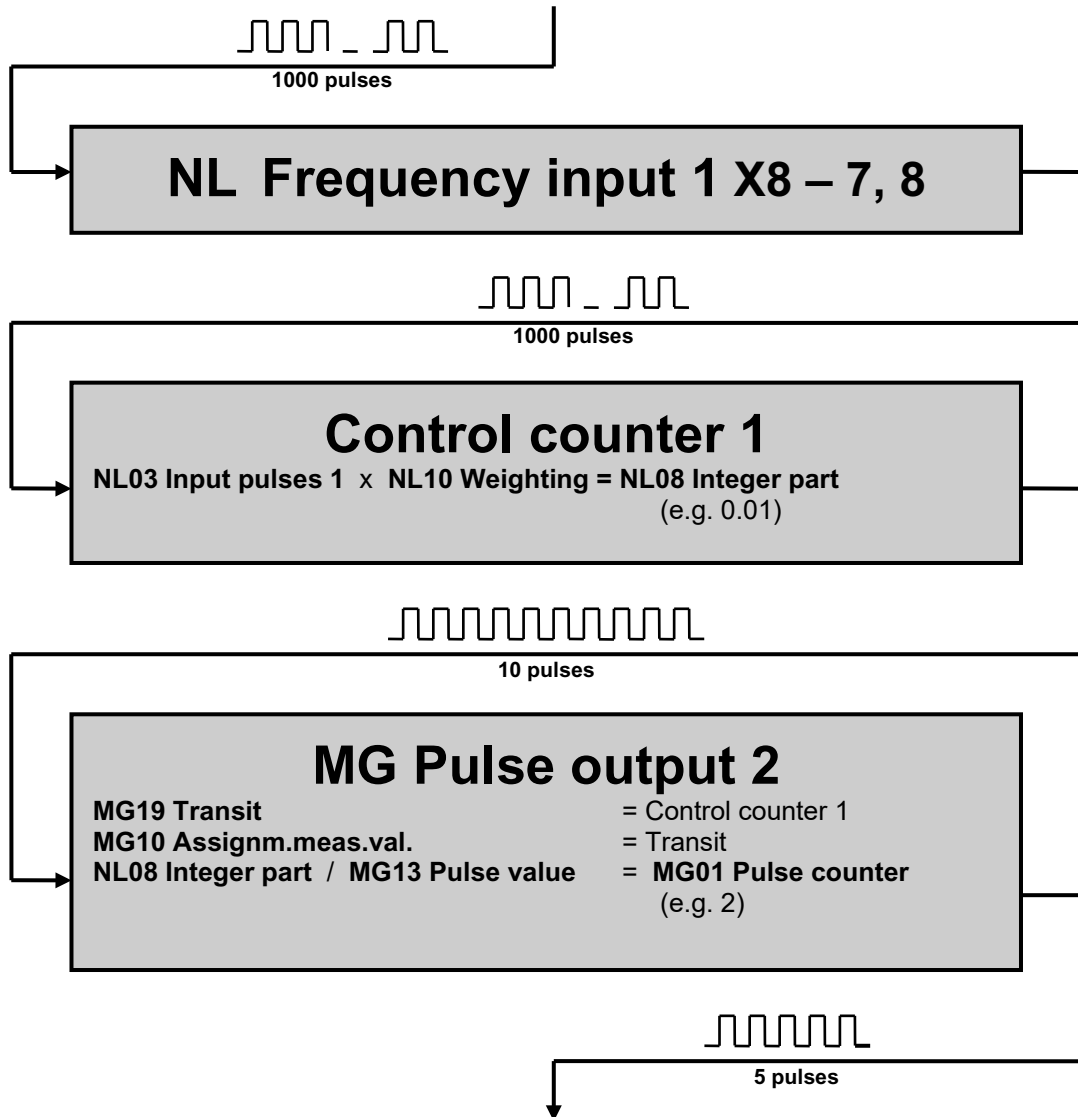


**Note**

There is no special operating mode for activation of special counters. They are supplied via the corresponding contact inputs and are active when a control evaluation is parameterized unequal to zero and pulses arrive at the input.

## A.4 Linking control totalizer with pulse output

Example: Control totalizer 1 (volume pulse) with pulse output 2



### Note

There is no special operating mode for activation of extra totalizers. They are supplied via the corresponding contact inputs and are active when a control evaluation is parameterized unequal to zero and pulses arrive at the input.



## A.5 Test functions

Functions for testing the device are provided in menu **F Test**. The following menus are available:

**FA Control panel, FB On-the-fly calibration, FC Freeze, FD Computing cycle, FE Calibration sd/Hs, FF Function test, FG Hardware test, FJ File system and FK Boole functions.**

359

### .A.5.1 FA Control panel

#### FA Quality Inspection of control panel

Access	Line	Designation	Value	Unit	Variable
I	1	Calibration lock		1	<a href="#">Eschalter</a>
I	2	counter touchscreen		205	<a href="#">touchcount</a>
I	3	counter home key		0	<a href="#">homecount</a>
B	4	refresh climate cab.	10	s	<a href="#">klimarefresh</a>

Enter Cancel Load defaults Refresh

**Figure 256: Menu FA Testing the control panel of the ERZ2000-NG**

#### **FA 01 Calibration lock**

Signals the status of the calibration switch on the front panel

- 0: closed
- 1: open

#### **FA02 counter touchscreen**

Indicates how often the screen was touched.

#### **FA03 counter home key**

Indicates how often the HOME key was actuated.

#### **FA04 refresh climate cab.**

The time setting here determines the scroll-down interval of the display. This is only provided for the factory testing of a brand-new device in the climate cabinet.

**.A.5.2 FB On-the-fly calibration****FB On-the-fly calibration**

Access Line	Designation	Value	Unit	Variable
D 2	Uncorr.vol.meas.	.0000	m3	<a href="#">feVu</a>
D 3	Corr.vol.meas.	.0000	m3	<a href="#">feVk</a>
D 4	Vol. at base cond.	.0000	*100 m3	<a href="#">feVn</a>
D 5	Quantity of energy	.0000	MWh	<a href="#">feE</a>
D 6	Mass	.0000	*100 kg	<a href="#">feM</a>
D 7	Time	.0000	s	<a href="#">feT</a>

Refresh

**Figure 257: Menu FB On-the-fly calibration**

The menu displays the values triggered in *chapter 2.5.5.2 On-the-fly calibration*.

**.A.5.3 FC Freeze****FC Freeze**

Access Line	Designation	Value	Unit	Variable
D 1	Time last freeze	27-09-2018 15:00:00		<a href="#">frzTime</a>
D 2	Freeze contact		OFF	<a href="#">ktkFreeze</a>
B 3	Freeze mode	Gas day		<a href="#">frzMode</a>
B 4	Freeze interval	30	s	<a href="#">frzInterval</a>
B 5	Source freeze cont.	OFF		<a href="#">kzoFreeze</a>

Enter

Cancel

Load defaults

Refresh

[Frozen values](#)[Freeze now, then show results](#)**Figure 258: Menu FC Freeze**

The menu displays the values triggered in *chapter 2.5.5.5 Freeze*.

### .A.5.4 FD Corrector cycle

#### FD Corrector cycle

Access Line	Designation	Value	Unit	Variable
D	1	Cycle duration	0.0345 s	<a href="#">Zyklus</a>
D	2	Program cycles	29 1/s	<a href="#">Zyklen</a>
D	3	Cycle counter	28405277	<a href="#">cycNo</a>

Refresh

**Figure 259: Menu FD Corrector circle**

FD02 Program cycles shows the number of computer cycles per second (33 cycles per second in this case).

### .A.5.5 FF Function test under running conditions

#### FF Function test under running conditions

Access Line	Designation	Value	Unit	Variable
D	1	Revision status	At rest	<a href="#">revStat</a>
Q	2	Time stamp 1	<input type="text" value="01-01-1970 01:00:00"/>	<a href="#">revStamp1</a>
Q	3	Time stamp 2	<input type="text" value="01-01-1970 01:00:00"/>	<a href="#">revStamp2</a>
Q	4	Time stamp 3	<input type="text" value="01-01-1970 01:00:00"/>	<a href="#">revStamp3</a>
Q	5	Time stamp 4	<input type="text" value="01-01-1970 01:00:00"/>	<a href="#">revStamp4</a>
Q	6	Revision run	<input type="text" value="1200"/>	s <a href="#">revPrf</a>
Q	7	Pre/post run	<input type="text" value="60"/>	s <a href="#">revVorNach</a>
Q	8	Delay	<input type="text" value="1"/>	s <a href="#">revDelay</a>
B	9	Partners address	<input type="text" value="OFF"/>	<a href="#">partner</a>
B	10	Partners entity	<input type="text" value="Flow comp. entity"/>	<a href="#">partInst</a>
C	11	Code 1 of partner	<input type="text" value="9999"/>	<a href="#">bpcode1</a>
C	12	Code 2 of partner	<input type="text" value="9999"/>	<a href="#">bpcode2</a>

Enter Cancel schedule Refresh

#### Result of function test

**Figure 260: Menu FC Function test under running conditions**

Similar to the DSfG revision, there are 4 time points that define the beginning, the interval and the end of a data recording. If the first time point is reached, the flow computer starts the data recording automatically, determines the mean values, etc. until the next time point and stops the recording at the last time point. A direct start can take place manually via the keyboard. For this purpose, select **Test <6>** and the cursor **down** to the chapter **Revision** and then start with the **Status** function with the **Enter** key.

The results are labeled in archives 11, 12 and 13 with the DSfG designations. The operating program (browser) with laptop is a better option and can be read in plain text.

Setting time points:

- **FF06 Revision run** defines the duration of the test
- **FF07 Pre/post run** defines the wait time between the start time and testing time and between the testing time end and stop time.
- **FF08 Delay** defines the start delay.

"schedule" under the menu enables definition of time specifications in advance at the click of a mouse before uploading by pressing the "Register" button on the ERZ2000-NG. The time of the connected PC is used as a basis for the preparation/after-run and testing time. In order to ensure that the time settings correspond to the real time, the PC time and ERZ time must be synchronized in advance. A daylight savings time delay of one hour is adjusted automatically and does not have to be corrected.

With coordinates **FF09 Partners address** and **FF10 Partner entity**, it is possible to transfer the time points for the defined operating point test in totalizers with series connection to a second ERZ2000-NG (in the series) and thus achieve a synchronized testing process. The transmission takes place via DSfG bus.

.A.5.6 FG Hardware test

**FG Hardware test**

Access	Line	Designation	Value	Unit	Variable
Y	1	Active	No		hwTest
I	2	Alarm contact	1		ktkAlarm
I	3	Warning contact	0		ktkWarn
I	4	Contact output	00FE	hex	KABits
D	7	Power LED	Flashes		LedNetz
D	8	Run LED	OFF		LedMess
D	9	Warning LED	OFF		LedWarn
D	10	Alarm LED	Flashes		LedAlarm
D	13	HFX test totalizer	0	pulses	resZpX
D	14	HFY test totalizer	0	pulses	resZpY
D	15	HFX-HFY diff.	0	pulses	difZpXY
I	16	Frequency input 1 -> <a href="#">NL01</a>	0.0000	Hz	hw_f1
I	17	Frequency input 2 -> <a href="#">NM01</a>	0.0000	Hz	hw_f2
I	18	Frequency input 3 -> <a href="#">NN01</a>	0.0000	Hz	hw_f3
I	19	Frequency input 4 -> <a href="#">NO01</a>	0.0000	Hz	hw_f4
I	20	Frequency input 5 -> <a href="#">NP01</a>	0.0000	Hz	hw_f5
I	21	Frequency input 6 -> <a href="#">NQ01</a>	0.0000	Hz	hw_f6
I	22	Frequency input 7 -> <a href="#">NR01</a>	0.0000	Hz	hw_f7
I	23	Frequency input 8 -> <a href="#">NS01</a>	0.0000	Hz	hw_f8
I	24	Current input 1 -> <a href="#">NA01</a>	0.0025	mA	hw_i1
I	25	Current input 2 -> <a href="#">NB01</a>	0.0000	mA	hw_i2
I	26	Current input 3 -> <a href="#">NC01</a>	0.0000	mA	hw_i3
I	27	Current input 4 -> <a href="#">ND01</a>	0.0000	mA	hw_i4
I	28	Current input 5 -> <a href="#">NE01</a>	0.0000	mA	hw_i5
I	29	Current input 6 -> <a href="#">NF01</a>	0.0000	mA	hw_i6
I	30	Current input 7 -> <a href="#">NG01</a>	0.0000	mA	hw_i7
I	31	Current input 8 -> <a href="#">NH01</a>	0.0000	mA	hw_i8
I	32	Current input 9 -> <a href="#">NU01</a>	0.6261	mA	hw_i9
I	33	Current input 10 -> <a href="#">NV01</a>	1.1215	mA	hw_i10
I	34	Current input 11 -> <a href="#">NW01</a>	0.0000	mA	hw_i11
I	35	Current input 12 -> <a href="#">NX01</a>	0.0000	mA	hw_i12
I	36	Inside temperature -> <a href="#">AL01</a>	35.9	°C	hw_qt
I	37	Resistance 1 -> <a href="#">NI01</a>	0.00	Ohm	hw_r1
I	38	Resistance 2 -> <a href="#">NJ01</a>	0.07	Ohm	hw_r2
I	39	Resistance 3 -> <a href="#">NY01</a>	136.59	Ohm	hw_r3
I	40	Resistance 4 -> <a href="#">NZ01</a>	0.07	Ohm	hw_r4
I	41	Contact input	00FF	hex	hw_ktkin
S	43	Testing aid	OFF		prfHlf

Refresh

**Figure 261: Menu FG Hardware test**

In normal operation and/or during the measurement, "no" is activated in coordinate **FG01 Active**. "yes" is selected during a hardware test or a simulation. The display test is initiated with coordinates **FG05** and **FG06** (not shown here). Coordinates **FG02 Alarm contact** to **FG09 Warning LED** show the statuses of the LEDs and the alarm, warning and contact outputs in a simulation. **FG13 HFX-Test totalizer** to **FG 15 HFX-HFY-diff.** display – if available – the already issued and counted

pulses and the difference of measuring and comparison channels. In **FG16 Frequency input 1** bis **FG23 Frequency input 8**, the primary measurement values of the frequency inputs are shown; **FG24 Current input 1** to **FG35 Current input 12** show the primary measurement values of the current inputs. **FG36 Internal temperature** shows the internal temperature of the ERZ2000-NG. **FG37 Resistance 1** to **FG40 Resistance 4** specify the primary measurements of the resistance inputs (for the temperature measurement). **FG43 Testing aid** shows the binary pattern of the contact inputs.

This provides a possibility of testing all inputs / outputs of the device:

If Menu FG Hardware test is set to "not active" (**FG01** to "no"), the current statuses of the display, LEDs and signal inputs and outputs are displayed by scrolling. If the menu is set to "active" (**FG01** to "yes"), the displayed inputs and/or outputs are influenced by the scrolling.

For example, the alarm contacts are activated, and the current output are set to fixed values: Current output 1 to 10mA, 2 to 11mA, 3 to 12mA, 4 to 13mA; the pulse outputs are switched: Pulse output 1 with 1 pulse/sec., 2 with 2 pulses/sec., 3 with 3 pulses/sec., 4 with 4 pulses/sec.

### .A.5.7 FJ File system

#### FJ File system

Access	Line	Designation	Value	Unit	Variable
D	1	percent free memo	98.360	%	<a href="#">dspace</a>
B	2	min. capacity warn	<input type="text" value="5.000"/>	%	<a href="#">dsWGwu</a>
D	3	total memory	3921.8	MByte	<a href="#">cfTotal</a>
D	4	available memory	3857.5	MByte	<a href="#">cfAvail</a>

**Figure 262: Menu FJ File system**

The following specifications relate to the internal SD memory card.

- Percent free  
Indicates the percentage of total available memory capacity that is still available.
- Warning free  
Defines the warning limit for capacity shortage.
- Memory total  
Indicates the maximum memory capacity of the SD card.

- Memory free  
Indicates how much memory capacity is still free.

**.A.5.8 FK Boole function**

**FK Boole functions**

Access Line	Designation	Value	Unit	Variable
D 10	Norm. function	1		<a href="#">isNormi</a>
D 17	New warning	0		<a href="#">zykNewWarn</a>
D 18	New alarm	0		<a href="#">zykNewAlarm</a>
D 19	New second	0		<a href="#">zykNewSec</a>
D 20	New second 30	0		<a href="#">zykNewSec30</a>
D 21	New minute	0		<a href="#">zykNewMin</a>
D 22	New hour	0		<a href="#">zykNewHour</a>
D 23	New day	0		<a href="#">zykNewDay</a>
D 24	New gas day	0		<a href="#">zykNewGasDay</a>
D 25	New month	0		<a href="#">zykNewMonth</a>
D 26	New gas month	0		<a href="#">zykNewGasMon</a>
D 27	New year	0		<a href="#">zykNewYear</a>
D 28	New gas year	0		<a href="#">zykNewGasYY</a>
D 29	Parameter flag	0		<a href="#">zykNewPar</a>
D 30	New key	0		<a href="#">zykNewKey</a>

Refresh

**Figure 263: Menu FK Boole function**

The values of the parameters of the truth functions are displayed in this menu.

## B) Updating software

Software in the following refers to the firmware running on the ERZ2000-NG.

### ⚠ Caution

**A change or update of the software is not necessary without consulting with the RMG service department!**

**Have this change or update carried out by the RMG service department.**

### ⚠ Caution

**For the installation of a new software the removal of seals is necessary, whereby the ERZ2000-NG and its operation immediately lose any approval under custody transfer law.**

**As further explained below, after successful installation of the software, the versions must be checked against the checksums on the base of the current approval, i.e. the approval must correspond to the EC type plate.**

**For a new legal for custody transfer it is necessary to reattach seals, which may only be done by a licensed official!!**

### B.1 Advance information

The main components of the device software are:

- The **Flow Computer BIOS**.
- The **application** with a special part, the calibration core.

Each part is identified by:

- **Version number**
- **Checksum**
- **Time stamp** (date and time of creation)

An SD memory card that is inserted at the bottom left behind the front panel contains files in the subdirectory \Bin for the Flow Computer BIOS and the application, e.g.:

\Bin\ERZ2000NG.exe (application)

\Bin\F2\_007.mot (Flow Computer BIOS)



When the device is switched off, the SD card can be removed in order to inspect and edit it on an external PC with a card reader. When switching on the device, the application file is read by the SD card and executed under Windows CE (operating system kernel). A new flow computer BIOS must be installed from the SD card to the internal flash memory with a special procedure. Then the BIOS is active!

## B.2 Software identification

There are various options for determining version number, checksum and time stamp of the software parts:

- When **switching on** the device

A few seconds after the device is switched on, the version numbers of BIOS and the application appear on the bottom right of the display under the green area.

There is no specification for the calibration core here.

- In the **coordinate system**, in menu **EJ Software identification**, see *Figure 10: Menu EJ Software identification*.

The option can be used on the touch screen under the menu "Functions", sub-menu "Type plate" (*chapter 2.5.5.3 Type plate*) or using the web browser.

### EG ID display

Access Line	Designation	Value	Unit	Variable
A *	1 Device	Family ERZ 2000-NG Type ERZ 2004 RMG Messtechnik		<a href="#">gerTyps</a>
A *	2 Official kernel	Official kernel Version 1.8 Checksum C075 16-09-2019 15:14:47		<a href="#">ekTyps</a>
A *	3 Application	Application Version 1.8.0 Checksum F0CD 16-09-2019 15:16:39		<a href="#">apTyps</a>
A *	4 Flow computer BIOS	Flow computer BIOS Version 2.008 Checksum 5AB5 21-10-2014 15:03:38		<a href="#">fcbTyps</a>
A *	5 WinCE kernel	WinCE kernel PicoMOD6 V1.11 Jun 18 2012 81455247		<a href="#">kernelTyps</a>
		Start-up 01-01-2020 01:00:00		

## B.3 Updating software

The update takes place by copying the new software to the SD card in the device.

### **⚠ Caution**

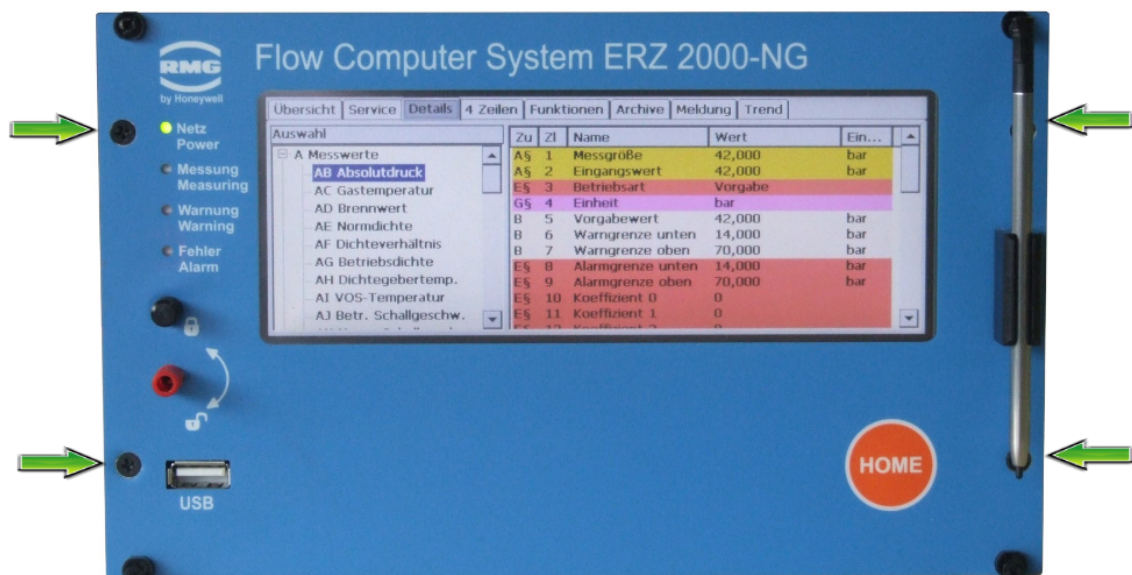
- Use software prepared for the RMG server only!
- In doing so, you can ensure that archive content and device parameters are not lost!

### Required tools

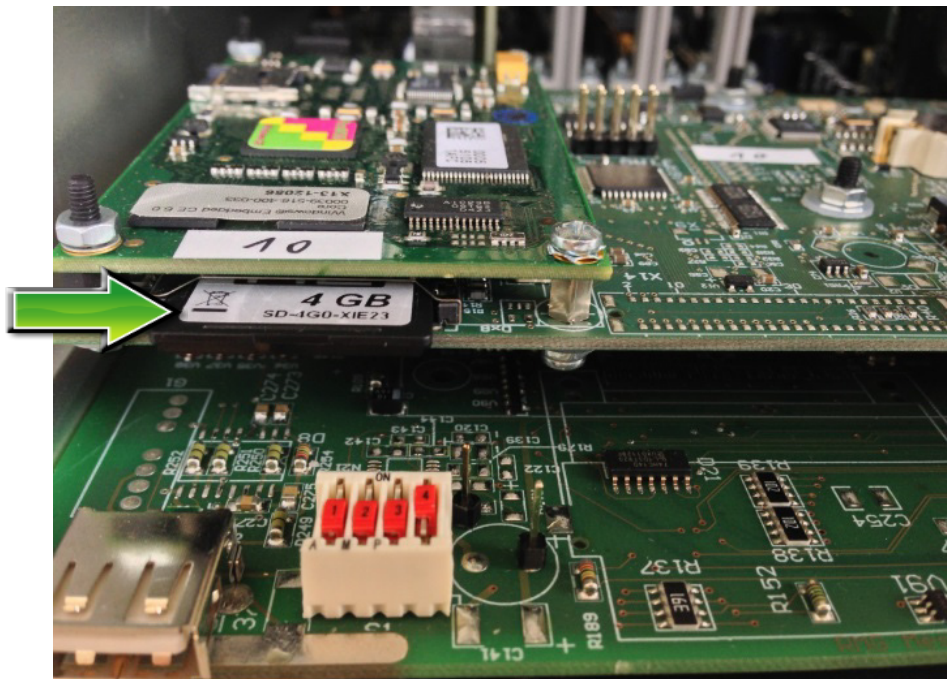
- Phillips screwdriver
- Network cable
- PC with network access
- SD card reader

### SD card removal

- Switch your measuring system to a safe state. If possible, discontinue the flow through the flow computer, because there is no computing during the software update and accumulating quantities are not measured.
- Switch off the ERZ2000-NG.
- Remove the four screws on the front panel and carefully pull it off.



- Remove the inserted SD card from the holder.



### SD card backup

- Backing of the entire SD card is highly recommended so that it is possible to reactivate the old software. This can be necessary, for instance, if an error occurs during the subsequent steps.
- Insert the SD card in a card reader.
- Copy the entire contents of the SD card to a separate backup directory on your PC.

**You should have received the software from the RMG service department.** The following required files should be loaded to the SD card to update the software:

*md5.txt*  
*version.txt*

and the subdirectories

*\Bin*  
*\ERZ2000NG*  
*\HTMLS*  
*\tools*

**Note**

**Please do not delete the files and directories on the SD!**

**Copy the new software completely to the SD.**

**The subdirectory \ERZ2000NG does not contain files for archive contents and parameters. This will overwrite an existing installation without losing any parameters or archives.**

- Re-insert the SD card (push it in the slot until it engages).
- Re-install the front panel (= reverse order of removal of the front panel).
- Switch on the ERZ2000-NG.
- The ERZ2000-NG is reactivated with the new software with unchanged parameters and with the existing archives.

**Enter activation key**

Enter the activation key for the new software, which is provided under coordinate **EJ10 Enable**. The activation key and the target CRC of the WinCe kernel can be found in the approval documentation under "Identification".

**Checking BIOS****Note**

**A BIOS update is usually not required since the same BIOS (2.008) has been used for several years.**

**Exceptions are "old" ERZ2000-NG.**

After the update, a new BIOS on the SD card is not automatically active. Therefore, check the device BIOS to determine whether it should be updated and re-installed if applicable; contact RMG customer service for information about the latest BIOS version.

## B.4 Installing BIOS

### Open the calibration switch

#### Prevent automatic resetting

- Activate coordinate **ED05 Service mode** ("yes") in order to prevent an automatic device reset (watchdog) during subsequent steps.

---

 371
 

---

#### Close the application

- Click on the "Service" tab on the touch screen (chapter "2.6. Functions", sub-menu "Service")
- Select and execute the "Exit program" function.

#### Start Windows Explorer

- Click on the "Start" button.
- Click on "Programs".
- Click on "Windows Explorer".

#### Start FlashloadCE

- "SDCard" (double-click)
- "TOOLS" (double-click)
- "FlashloadCE" (double-click)

#### Monitor the output window

- After the program start, messages that the COM3 and CAN-bus required for flashing have been opened must appear:

„CAN opened successfully!“  
„COM3: opened successfully!“

#### Start the bootloader

- Click on the menu item "Flash > Reset BIOS".

#### Monitor FlashloadCe

- A message that the connection between FlashloadCE and the bootloader was established appears in the output window (to the right):

"Device is connected!"

- Various information can be read in the status window (to the left), such as the version of the bootloader.

### Load flow computer BIOS

- Click on the menu item "File > Open".
- Select the BIOS file on the "SDCard" in the subdirectory "Bin".  
Such files have the name extension ".mot", e.g. "F2\_007.mot".  
Then confirm the file selection with the "OK" button.

### Monitor the output window:

- The file is now checked for validity.  
This takes a few seconds and the following message appears  
"Scanning file. Please wait ..."
- If the file is valid, some information is displayed:  
"Motorola file"  
"Number of lines"  
"Bytes to program"  
"Checksum"

### Delete flash memory

- Click on the menu item "Flash > Clear".

### Monitor the output window:

- After the deletion process is successfully completed, a message that the flash memory was deleted appears:  
"Flash memory is blank"

### Program the flash memory

- Click on the menu item "Flash > Program".

### Monitor the output window:

- The following message appears  
"Programming memory ..."

with a progress indicator. It is possible that the bar makes large jumps. This only means that part of the flash memory does not have to be programmed.

- When the programming process is completed, the following message appears:  
"Device programmed!"

The checksum must be checked as described in chapter "2.2 Checksum".

**Activate new BIOS**

- Click on the menu item "Flash > Make valid" in order to activate the now programmed and verified BIOS.

<b>Note</b>
<b>Attention: This step is important.</b>

**Monitor the output window**

- The following message appear after the activation:  
"Target has been made valid!"

**Start the software**

- Click on the menu item "Flash > Start target".
- A window appears in which the program start must be confirmed again with "Yes". In this case, the entire ERZ2000 NG is restarted.

**B.5 Activation after software update**



There is an activation key for each software package, which must be entered after a software update of the ERZ2000-NG. The device calculates a checksum internally and compares it with the key that has been entered. The ERZ2000-NG is only ready for operation if the result of this comparison is positive. If the activation key is missing or incorrect, the ERZ2000-NG switches permanently to fault status and issues the alarm "A 98-8 Release missing". The computing functions are executed normally, but the disturbance totalizers run.

## C) Archive assignment, depth and identification

### C.1 Archive groups

Multiple menus can be assigned to archives.

374

#### Note

In order to display mean values for pressure, temperature, etc. in the archives or archive groups, a setting not equal to "off" must be selected for the relevant measurement operating mode.

If a measurement input works in the "Random" operating mode, no entries are created in the archives or log book when alarms are generated and deleted.



### .C.1.1 OA DSfG archive

#### OA DSfG archives

Access Line	Designation	Value	Unit	Variable
K	1	Std.query 1	Standard query	<a href="#">stdabf1</a>
K	2	Std.query 2	Standard query	<a href="#">stdabf2</a>
D	3	Level FROM 2	4917	<a href="#">s2von</a>
D	4	Level TO 2	13108	<a href="#">s2bis</a>
K	5	Std.query 3	Standard query	<a href="#">stdabf3</a>
K	6	Std.query 4	Standard query	<a href="#">stdabf4</a>
D	7	Level FROM 4	4917	<a href="#">s4von</a>
D	8	Level TO 4	13108	<a href="#">s4bis</a>
K	9	Std.query 5	Standard query	<a href="#">stdabf5</a>
D	10	Level FROM 5	1	<a href="#">s5von</a>
D	11	Level TO 5	4836	<a href="#">s5bis</a>
K	12	Std.query 6	Standard query	<a href="#">stdabf6</a>
D	13	Level FROM 6	1	<a href="#">s6von</a>
D	14	Level TO 6	6555	<a href="#">s6bis</a>
K	15	Std.query 7	Standard query	<a href="#">stdabf7</a>
D	16	Level FROM 7	1	<a href="#">s7von</a>
D	17	Level TO 7	6553	<a href="#">s7bis</a>
K	18	Std.query 1a	Standard query	<a href="#">stdabf1a</a>
K	19	Std.query 2a	Standard query	<a href="#">stdabf2a</a>
D	20	Level FROM 2a	4917	<a href="#">s2avon</a>
D	21	Level TO 2a	13108	<a href="#">s2abis</a>
K	22	Std.query 3a	Standard query	<a href="#">stdabf3a</a>
K	23	Std.query 4a	Standard query	<a href="#">stdabf4a</a>
D	24	Level FROM 4a	4917	<a href="#">s4avon</a>
D	25	Level TO 4a	13108	<a href="#">s4abis</a>
K	26	Std.query 5a	Standard query	<a href="#">stdabf5a</a>
D	27	Level FROM 5a	1	<a href="#">s5avon</a>
D	28	Level TO 5a	4836	<a href="#">s5abis</a>
K	29	Std.query 6a	Standard query	<a href="#">stdabf6a</a>
D	30	Level FROM 6a	1	<a href="#">s6avon</a>
D	31	Level TO 6a	6555	<a href="#">s6abis</a>
K	32	Std.query 7a	Standard query	<a href="#">stdabf7a</a>
D	33	Level FROM 7a	1	<a href="#">s7avon</a>
D	34	Level TO 7a	6553	<a href="#">s7abis</a>
K	35	Std.query 1b	Standard query	<a href="#">stdabf1b</a>
K	36	Std.query 2b	Standard query	<a href="#">stdabf2b</a>
D	37	Level FROM 2b	4917	<a href="#">s2bvon</a>
D	38	Level TO 2b	13108	<a href="#">s2bbis</a>
K	39	Std.query 3b	Standard query	<a href="#">stdabf3b</a>
K	40	Std.query 4b	Standard query	<a href="#">stdabf4b</a>
D	41	Level FROM 4b	4917	<a href="#">s4bvon</a>
D	42	Level TO 4b	13108	<a href="#">s4bbis</a>
K	43	Std.query 5b	Standard query	<a href="#">stdabf5b</a>
D	44	Level FROM 5b	1	<a href="#">s5bvon</a>
D	45	Level TO 5b	4836	<a href="#">s5bbis</a>
K	46	Std.query 6b	Standard query	<a href="#">stdabf6b</a>
D	47	Level FROM 6b	1	<a href="#">s6bvon</a>
D	48	Level TO 6b	6555	<a href="#">s6bbis</a>
K	49	Std.query 7b	Standard query	<a href="#">stdabf7b</a>
D	50	Level FROM 7b	1	<a href="#">s7bvon</a>
D	51	Level TO 7b	6553	<a href="#">s7bbis</a>
K	52	Std.query R1	Standard query	<a href="#">stdabfR1</a>
D	53	Level FROM R1	5	<a href="#">sR1von</a>
D	54	Level TO R1	8	<a href="#">sR1bis</a>
K	55	Std.query R2	Standard query	<a href="#">stdabfR2</a>
D	56	Level FROM R2	5	<a href="#">sR2von</a>
D	57	Level TO R2	8	<a href="#">sR2bis</a>
K	58	Std.query R3	Standard query	<a href="#">stdabfR3</a>
D	59	Level FROM R3	5	<a href="#">sR3von</a>
D	60	Level TO R3	8	<a href="#">sR3bis</a>
K	61	Std.query 9	Standard query	<a href="#">stdabf9</a>
D	62	Level FROM 9	0	<a href="#">s9von</a>
D	63	Level TO 9	0	<a href="#">s9bis</a>
K	64	Std.query 11	Standard query	<a href="#">stdabf11</a>
D	65	Level FROM 11	0	<a href="#">s11von</a>
D	66	Level TO 11	0	<a href="#">s11bis</a>
K	67	Std.query 12	Standard query	<a href="#">stdabf12</a>
D	68	Level FROM 12	0	<a href="#">s12von</a>
D	69	Level TO 12	0	<a href="#">s12bis</a>
K	70	Std.query 13	Standard query	<a href="#">stdabf13</a>
D	71	Level FROM 13	0	<a href="#">s13von</a>
D	72	Level TO 13	0	<a href="#">s13bis</a>
K	73	Std.query 9b	Standard query	<a href="#">stdabf9b</a>
D	74	Level FROM 9b	1	<a href="#">s9bvon</a>
D	75	Level TO 9b	7400	<a href="#">s9bbis</a>
K	76	Std.query 11b	Standard query	<a href="#">stdabf11b</a>
D	77	Level FROM 11b	1	<a href="#">s11bvon</a>
D	78	Level TO 11b	7400	<a href="#">s11bbis</a>
K	79	Std.query 12b	Standard query	<a href="#">stdabf12b</a>
D	80	Level FROM 12b	1	<a href="#">s12bvon</a>
D	81	Level TO 12b	5394	<a href="#">s12bbis</a>
K	82	Std.query 13b	Standard query	<a href="#">stdabf13b</a>
D	83	Level FROM 13b	1	<a href="#">s13bvon</a>
D	84	Level TO 13b	5394	<a href="#">s13bbis</a>
K	85	Std.query F1A	Standard query	<a href="#">stdabfF1A</a>
K	86	Std.query F1B	Standard query	<a href="#">stdabfF1B</a>
D	87	Level FROM F1B	1197	<a href="#">sF1Bvon</a>
D	88	Level TO F1B	9388	<a href="#">sF1Bbis</a>
K	89	Std.query F2A	Standard query	<a href="#">stdabfF2A</a>
D	90	Level FROM F2A	1197	<a href="#">sF2Avon</a>
D	91	Level TO F2A	9388	<a href="#">sF2Abis</a>
K	92	Std.query F2B	Standard query	<a href="#">stdabfF2B</a>
D	93	Level FROM F2B	1197	<a href="#">sF2Bvon</a>
D	94	Level TO F2B	9388	<a href="#">sF2Bbis</a>
K	95	Std.query F2C	Standard query	<a href="#">stdabfF2C</a>
D	96	Level FROM F2C	1197	<a href="#">sF2Cvon</a>
D	97	Level TO F2C	9388	<a href="#">sF2Cbis</a>

Figure 264: Menu OA DSfG archive

Various DSfG parameters are displayed in menu **OA DSfG archive** strictly for diagnostic purposes.

### .C.1.2 OC Function

#### OC Function

Access Line	Designation	Value	Unit	Variable
D 1	not available			nichtDa

Refresh

Figure 265: Menu OC Function

Menu **OC Function** has only one single coordinate **OC01 Not available**. This function coordinate is required for the handling of **OU Free programmable archive**. If an archive channel should not be used, it is assigned to **OC01 Not available**. Then, the channel appears in the archive and/or is no longer available. Example:

Do not use Archive channel 7: **OU16 Assignm. Channel 7 = OC01**

### .C.1.3 OD Input values

#### OD Input values

Access Line	Designation	Value	Unit	Variable
I 4	FCBios-cycles	1542	Hz	fcbloops
I 13	Pulse comp. line 1	0		hwPVgl12
I 14	Pulse comp. line 2	0		hwPVgl34
I 15	Start-up line 1	No		anlauf12
I 16	Start-up line 2	Yes		anlauf34
I 18	Base time-second	1893071147		baseTimer
I 19	Base clock-second	0.993195	s	baseZyk
I 24	Missing pulses	0		pulsAusfall
I 25	Base clock-HF1/2	1.000	s	baseZ12
I 26	Base clock-HF3/4	1.000	s	baseZ34
I 27	Base time-HF1/2	1899978555		baseTim12
I 28	Base time-HF3/4	1900107140		baseTim34
I 30	IGM timer	0		igmTimer
A * 31	IGM time slice	0.000000	s	igmTZyk
D 32	time slice	1.000	s	fleichZ
I 33	DP-Timer raw value	1896157252		wqTimer
I 35	Act. dp-current	0		aktAbr
I 36	dp current no.	0		sllAbr
D 37	dp qual. timer	0	s	wgQCnt
D 38	Qm-Freq. rough	0.0000	Hz	quickf
D 39	Qm-Freq. precis.	0.0000	Hz	slowf
D 40	Qm trend rough	0	%	qminsf
D 41	Pulse comp. ignor.	Yes		suppress
D 42	Qm rough	0.000	m3/h	qikflw
I 43	Volume unit			vDzuEinh
I 44	Flow unit			qDzuEinh
I 45	VOS unit			sDzuEinh

Refresh

Figure 266: menu OD Input values

Various DSfG parameters are displayed in menu **OD Input values** strictly for diagnostic purposes.

**.C.1.4 OE Miscellaneous**

**OE Miscellaneous**

Access Line	Designation	Value	Unit	Variable
D 1	relative density	0.5851		dvRn
I 8	State	Offline		dsfgState
A * 19	Counting check 1	<b>1805423</b>		before
A * 20	Counting check 2	<b>1805423</b>		after
D 21	Receipt MOD520	20488806		canRcvTg
I 22	Send M32 OK	20488814		canTrmOk
I 23	Send M32 err	90		canTrmNok
D 24	Receipt difference	8		canTrmDif
I 25	Burst telegrams	0		runNr
Q 26	CAN burst	<input type="text" value="0"/>		burstCAN
A * 27	Qm freq. main	<b>0.0000</b>	Hz	gvuFXu
A * 28	Qm freq. ref.	<b>0.0000</b>	Hz	gvuFYu
D 29	Roughness	1.00000		fGlatt
D 30	Current coordinate	3045		aktKoo
D 31	Current key	16		aktKey
D 41	Status mom.values	Okay		momEstt
D 42	State	At rest		feState
D 49	Aux. value string			arvString
D 50	Aux. value long	0		arvLong
D 51	Last event	5779		lEvt
D 52	Time of last event	26-09-2018 14:25:00		TIEvt
K 62	Magic number	47110815		magicNo
K 63	magic number 2	11471580		magicNo2
D 67	Time of power fail	19-09-2018 10:50:15		pfailt
D 68	power outage time	42 s		pfails
D 70	Copy gas vol. dir.1	.000000	m3	cqDzu1Zw
D 71	Copy gas vol. dir.2	.000000	m3	cqDzu2Zw
D 79	Noise	135		irandom
I 80	Power fail	0		pfailf
D 81	Parameter flag	0		savePars
D 82	Msgs. at issue	3		actErrors
D 83	cummulated Msgs.	3		cumErrors
A * 84	Checksum parameter	<b>00000000</b>		dbprf
D 85	Used range	0		QeMb
D 86	Used range	0		QmMb
D 87	Used range	0		QnMb
D 88	Used range	0		QuMb
D 89	Used range	0		QkMb
D 90	Used range	0		ZuMb
D 91	Used range	0		kzIMb
D 92	damaged EZD-Tg.	0		ezdDefekt
D 93	DSfG status	Stop		dzuEstt
D 94	power of ten	0		dzuWrt
D 98	Samples event/hour	665		finstESmpl
D 99	Samples per hour	665		finstHSmpl

Enter Cancel Load defaults Refresh

**Figure 267: Menu OE Miscellaneous**

Various parameters are displayed in menu **OE Miscellaneous** strictly for diagnostic purposes.

### .C.1.5 OU Freely programmable archive

#### OU Free programmable archive

Access Line	Designation	Value	Unit	Variable
B 1	Record cycle	OFF		<a href="#">fpagZyk</a>
B 10	Assign.Channel 1 = <a href="#">AD01</a>	<a href="#">Edit</a>	kWh/m3	<a href="#">fpagk1</a>
B 11	Assign.Channel 2 = <a href="#">AE01</a>	<a href="#">Edit</a>	kg/m3	<a href="#">fpagk2</a>
B 12	Assign.Channel 3 = <a href="#">LB10</a>	<a href="#">Edit</a>	m3	<a href="#">fpagk3</a>
B 13	Assign.Channel 4 = <a href="#">LC04</a>	<a href="#">Edit</a>	MWh	<a href="#">fpagk4</a>
B 14	Assign.Channel 5 = <a href="#">LC01</a>	<a href="#">Edit</a>	*100 m3	<a href="#">fpagk5</a>
B 15	Assign.Channel 6 = <a href="#">OC01</a>	<a href="#">Edit</a>		<a href="#">fpagk6</a>
B 16	Assign.Channel 7 = <a href="#">LB07</a>	<a href="#">Edit</a>	m3	<a href="#">fpagk7</a>
B 17	Assign.Channel 8 = <a href="#">LD01</a>	<a href="#">Edit</a>	*100 m3	<a href="#">fpagk8</a>
B 18	Assign.Channel 9 = <a href="#">LD10</a>	<a href="#">Edit</a>	m3	<a href="#">fpagk9</a>
B 19	Assign.Channel 10 = <a href="#">LE04</a>	<a href="#">Edit</a>	MWh	<a href="#">fpagk10</a>
B 20	Assign.Channel 11 = <a href="#">LE01</a>	<a href="#">Edit</a>	*100 m3	<a href="#">fpagk11</a>
B 21	Assign.Channel 12 = <a href="#">LE10</a>	<a href="#">Edit</a>	m3	<a href="#">fpagk12</a>
B 22	Assign.Channel 13 = <a href="#">HB01</a>	<a href="#">Edit</a>	kW	<a href="#">fpagk13</a>
B 23	Assign.Channel 14 = <a href="#">HD01</a>	<a href="#">Edit</a>	m3/h	<a href="#">fpagk14</a>
B 24	Assign.Channel 15 = <a href="#">HE01</a>	<a href="#">Edit</a>	m3/h	<a href="#">fpagk15</a>
B 25	Assign.Channel 16 = <a href="#">AB01</a>	<a href="#">Edit</a>	MPa	<a href="#">fpagk16</a>
B 26	Assign.Channel 17 = <a href="#">AC01</a>	<a href="#">Edit</a>	K	<a href="#">fpagk17</a>
B 27	Assign.Channel 18 = <a href="#">AD01</a>	<a href="#">Edit</a>	kWh/m3	<a href="#">fpagk18</a>
B 28	Assign.Channel 19 = <a href="#">AE01</a>	<a href="#">Edit</a>	kg/m3	<a href="#">fpagk19</a>
B 29	Assign.Channel 20 = <a href="#">AE01</a>	<a href="#">Edit</a>	kg/m3	<a href="#">fpagk20</a>
D 30	GQ trigger	00000000	hex	<a href="#">qbhTriqger</a>
D 31	GQ trig. pattern	00000000	hex	<a href="#">qbhTrqPatt</a>

Enter Cancel Load defaults Refresh

**Figure 268: Menu OU Freely programmable archive**

In order for the freely programmable archive to be detected when loading file as archive group 15, an assignment not equal to "off" must be selected in coordinate **U001 Record cycle** (e.g. "every minute").

If an archive channel should not be used, it is assigned to **OC01 Not available** (see above). Then, **Channel X = [OC01](#)** and the corresponding channel X is not in the archive and/or is not available.

.C.1.6 OV Dialogs

OV Dialogs

Access	Line	Designation	Value	Unit	Variable
D	1	dlgArchive	Order-No		<a href="#">dlgArchive</a>
D	2	DlgFunctions 1	Drag indicator		<a href="#">dlgFunktio</a>
D	3	DlgFunctions 2	Time 1		<a href="#">dlgFunktio2</a>
D	4	DlgFunctions 3	Partner's addr.		<a href="#">dlgFunktio3</a>
D	5	dlgUebersi	Analysis		<a href="#">dlgUebersi</a>
D	6	dlgCommon	Xs		<a href="#">dlgCommon</a>
D	7	dlgFehler	Status		<a href="#">dlgFehler</a>
D	8	dlgService	Volume		<a href="#">dlgService</a>
D	9	dlgEditKoo	Minimum value		<a href="#">dlgEditKoo</a>
D	10	dlgAnzeige	Overview		<a href="#">dlgAnzeige</a>
D	11	dlgWait	WRONGBIOS		<a href="#">dlgWait</a>
D	12	dlgSrvCmd	<please select>		<a href="#">dlgSrvCmd</a>
D	13	DlgKeybNum	1		<a href="#">dlgKeybNum</a>
D	14	DlgTrend	INV_DT		<a href="#">dlgTrend</a>

Refresh

**Figure 269: Menu OV Dialogs**

Various archive views are displayed in menu **OV Dialog texts** for diagnostic purposes.

### .C.1.7 OW Text for Browser

#### OW Texts for Browser

Access Line	Designation	Value	Unit	Variable
D 1	Meaning Bit pattern	0: Alarm		<a href="#">blbits</a>
D 2	Accuracy test	Pre run		<a href="#">bpprf</a>
D 3	Group name A-M	Measured values		<a href="#">grpNames1</a>
D 4	Group name N-Z	Inputs		<a href="#">grpNames2</a>
D 5	access types	Access		<a href="#">accesses</a>
D 6	Data types 1	Data type		<a href="#">datatp1</a>
D 7	Data types 2	double		<a href="#">datatp2</a>
D 8	Docu generation	Line		<a href="#">docugen</a>
D 9	helpline	Text		<a href="#">helpline</a>
D 10	Binary code control	Module		<a href="#">codechk</a>
D 20	Diverse 3	Parameterization		<a href="#">divers3</a>
D 21	Diverse 4	Load defaults		<a href="#">divers4</a>
D 22	Diverse 5	settable under		<a href="#">divers5</a>
D 23	Diverse 6	Modbus		<a href="#">divers6</a>
D 24	Diverse 7	Value (display)		<a href="#">divers7</a>
D 25	Diverse 8	Overview		<a href="#">divers8</a>
D 26	Diverse 9	Pictures		<a href="#">divers9</a>
D 27	Diverse 10	Components		<a href="#">divers10</a>
D 28	Diverse 11	Frozen values		<a href="#">divers11</a>
D 29	Diverse 12	Parameter check		<a href="#">divers12</a>
D 30	Diverse 13	region		<a href="#">divers13</a>
D 31	Diverse 14	V-Meas. parameters		<a href="#">divers14</a>

Refresh

**Figure 270: Menu OW Text for Browser**

Various browser views are displayed in menu **OW Text** for **Browser** strictly for diagnostic purposes.

.C.1.8 OY special values DSfG

OY special values DSfG

Access Line	Designation	Value	Unit	Variable
D 1	signed by DFUE	1		<a href="#">dfusign</a>
D 2	signed by device	0		<a href="#">dfuselek</a>
D 3	signature method	0		<a href="#">dfuverf</a>
D 4	time expired	DD-MM-YYYY hh:mm:ss		<a href="#">expired</a>
D 5	EADR of sender			<a href="#">AbseEadr</a>
D 6	Current entity			<a href="#">myInst</a>
D 7	Current address	OFF		<a href="#">myAdr</a>
B 8	Orig.doc. printer	<input type="text" value="0"/>		<a href="#">urbeldr</a>
B 9	Data memory	<input type="text" value="0"/>	kByte	<a href="#">speicher</a>
B 10	Battery change	<input type="text" value="14-03-2016 16:37:37"/>		<a href="#">TlBatt</a>
D 11	Billing	1		<a href="#">abrTypI</a>
D 12	No. bill.modes	2		<a href="#">anzAMI</a>
D 13	EOS-algorithm	3		<a href="#">kalqoI</a>
D 14	Eval. subst. val.	0		<a href="#">erwbldB</a>
D 15	Eval. subst. val.	0		<a href="#">erwbldI</a>
D 16	Behaviour totaliz	0		<a href="#">verhHZWB</a>
D 17	Behaviour totaliz	0		<a href="#">verhHZWI</a>
D 18	User lock	0		<a href="#">Bschalter</a>
D 19	Hash value		hex	<a href="#">actHash</a>
D 20	Signature R		hex	<a href="#">sign_R</a>
D 21	Signature S		hex	<a href="#">sign_S</a>
D 22	Number of paths	0		<a href="#">NrOfPath</a>
D 23	Signed archives	1		<a href="#">dfusign2</a>
D 24	Archive line-by-line	1		<a href="#">arvzlw</a>
D 31	Calorific value	11.250	kWh/m3	<a href="#">hoCopy</a>
D 32	standard density	0.75651	kg/m3	<a href="#">rhonCopy</a>
D 33	Relative density	0.5549		<a href="#">dvCopy</a>
D 34	GQ trigger	00000000	hex	<a href="#">gbh2Trigger</a>
D 35	GQ trig. pattern	00000000	hex	<a href="#">gbh2TrqPatt</a>

Figure 271: Menu OY OY special values DSfG

Various DSfG parameters are displayed in menu **OY special values DSfG** strictly for diagnostic purposes.

### .C.1.9 OZ DSfG archive part 2

#### OZ DSfG archives part2

Access Line	Designation	Value	Unit	Variable
K 1	Std.query 14a	Standard query		<a href="#">stdabf14a</a>
K 2	Std.query 14b	Standard query		<a href="#">stdabf14b</a>
D 3	Level FROM 14b		1	<a href="#">s14bvon</a>
D 4	Level TO 14b		7	<a href="#">s14bbis</a>
K 5	Std.query 15a	Standard query		<a href="#">stdabf15a</a>
K 6	Std.query 15b	Standard query		<a href="#">stdabf15b</a>
D 7	Level FROM 15b		1	<a href="#">s15bvon</a>
D 8	Level TO 15b		7	<a href="#">s15bbis</a>

Refresh

Figure 272: Menu OZ DSfG archive part 2

Various DSfG parameters are displayed in menu **OZ DSfG archive part 2** strictly for diagnostic purposes.

### .C.1.10 Archive groups

There are 24 different archive groups in which the specified values, including time stamp (date and time) and ordinal numbers are specified.

#### Archive group 1: counters and measured values billing mode 1 Ordinal No. 13085 ... 13108

Time stamp	Ordinal No.	* Totalizer BM1 / Original totalizer	* Totalizer BM1 / Corr.vol.meas.	* Totalizer BM1 / Vol. at base cond.
-	-	caafd/baag	caagd/baae	caahd/baaa
dd-mo-yyyy hh:mi:ss	-	m3	m3	*100 m3
26-09-2018 18:00:00	13085	0	111118	76810
26-09-2018 19:00:00	13086	0	111118	76810
26-09-2018 20:00:00	13087	0	111118	76810
26-09-2018 21:00:00	13088	0	111118	76810
26-09-2018 22:00:00	13089	0	111118	76810
26-09-2018 23:00:00	13090	0	111118	76810
27-09-2018 00:00:00	13091	0	111118	76810

...

Figure 273: Archive group 1

The channel status is specified with color-coding (black, gray, blue, green, turquoise and yellow).

#### Channel status

- Okay
- Stop
- **Default value**
- **Fixed value**
- **Holding value**
- **Revision**

Figure 274: Archive group 1 channel status



TSV file

Ordinal No.	Number	state	from	to
<a href="#">13001 ... 13108</a>	108	grows	23-09-2018 08:00:00	27-09-2018 17:00:00
<a href="#">12501 ... 13000</a>	500	complete	03-09-2018 12:00:00	23-09-2018 07:00:00
<a href="#">12001 ... 12500</a>	500	complete	13-08-2018 16:00:00	03-09-2018 11:00:00
<a href="#">11501 ... 12000</a>	500	complete	25-06-2018 14:00:00	13-08-2018 15:00:00
<a href="#">11001 ... 11500</a>	500	complete	04-06-2018 20:00:00	25-06-2018 13:00:00
<a href="#">10501 ... 11000</a>	500	complete	15-05-2018 00:00:00	04-06-2018 19:00:00
<a href="#">10001 ... 10500</a>	500	complete	24-04-2018 04:00:00	14-05-2018 23:00:00
<a href="#">9501 ... 10000</a>	500	complete	03-04-2018 10:00:00	24-04-2018 03:00:00
<a href="#">9001 ... 9500</a>	500	complete	13-03-2018 13:00:00	03-04-2018 09:00:00
<a href="#">8501 ... 9000</a>	500	complete	20-02-2018 17:00:00	13-03-2018 12:00:00
<a href="#">8001 ... 8500</a>	500	complete	30-01-2018 21:00:00	20-02-2018 16:00:00
<a href="#">7501 ... 8000</a>	500	complete	10-01-2018 01:00:00	30-01-2018 20:00:00
<a href="#">7001 ... 7500</a>	500	complete	18-12-2017 19:00:00	10-01-2018 00:00:00
<a href="#">6501 ... 7000</a>	500	complete	03-06-2017 20:00:00	18-12-2017 18:00:00
<a href="#">6001 ... 6500</a>	500	complete	12-05-2017 12:00:00	03-06-2017 19:00:00
<a href="#">5501 ... 6000</a>	500	complete	22-04-2017 14:00:00	12-05-2017 11:00:00
<a href="#">5001 ... 5500</a>	500	complete	01-04-2017 23:00:00	22-04-2017 13:00:00
<a href="#">4917 ... 5000</a>	84	shrinks	29-03-2017 11:00:00	01-04-2017 22:00:00

Figure 275: Archive group 1

The bottom display in the menu **Archive group 1 / Totalizer BM1** shows that the data is saved in TSV files (Excel-compatible format). The files can be read and downloaded by double-clicking on the indenture numbers, e.g. [1 ... 500](#).

The other archives have a similar structure. There are additional archive groups:

- QA Archive group 1 Main totalizer for AM 1 plus measurements
- QB Archive group 2 Disturbance totalizer for AM 1
- QC Archive group 3 Main totalizer for AM 2 plus measurements
- QD Archive group 4 Disturbance totalizer for AM 2
- QE Archive group 5 Main totalizer for AM 3 plus measurements
- QF Archive group 6 Disturbance totalizer for AM 3
- QG Archive group 7 Main totalizer for AM 4 plus measurements
- QH Archive group 8 Disturbance totalizer for AM 4
- QI Archive group 9 Instance F 1b
- QJ Archive group 10 Instance F 2a
- QK Archive group 11 Instance F 2b+c
- QL Archive group 12 GC
- QM Archive group 13 Totalizers for undefined AM
- QN Archive group 14 Tandem comparison results

QO	Archive group 15	Freely programmable archive
QP	Archive group 16	Assigned with special inputs ("MRG functions" stage 1)
QQ	Archive group 17	DSfG revision and/or official custody transfer revision part 1
QR	Archive group 18	DSfG revision and/or official custody transfer revision part 2
QS	Archive group 19	DSfG revision and/or official custody transfer revision part 3
QT	Archive group 20	DSfG revision and/or official custody transfer revision part 4
QU	Archive group 21	Log book plus revision trail
QV	Archive group 22	Highest load per day, hourly value
QW	Archive group 23	Highest load per month, hourly and daily value
QX	Archive group 24	Highest load per year, hourly and daily value

## C.2 Archive depth

### DSfG archive

Archive group 1 to 8	8192 entries, then the oldest entry is overwritten.
Archive group 9 to 11	8192 entries, then the oldest entry is overwritten.
Archive group 12	8192 entries, then the oldest entry is overwritten.
Archive group 13	8192 entries, then the oldest entry is overwritten.
Archive group 14, 15, 16	8192 entries, then the oldest entry is overwritten.
Archive group 17 to 20	4 entries, are rewritten each time.
Archive group 21	8192 entries, then the oldest entry is overwritten.
Archive group 22	180 entries, then the oldest entry is overwritten.
Archive group 23	36 entries, then the oldest entry is overwritten.
Archive group 24	10 entries, then the oldest entry is overwritten.

## C.3 Archive identifications

Text for identification of the corresponding archive group can be entered in coordinates **ID05** to **ID12**. The DSfG call-up system reads these archive identifications (archive names) when detecting the master data and uses them for visualization.

## D) Determination of the correction factor for a current input

Determination of the correction factor for, e.g. the measuring pressure input (menu **AB Absolute pressure**), which should be measured in a range of 20 to 70 bar.

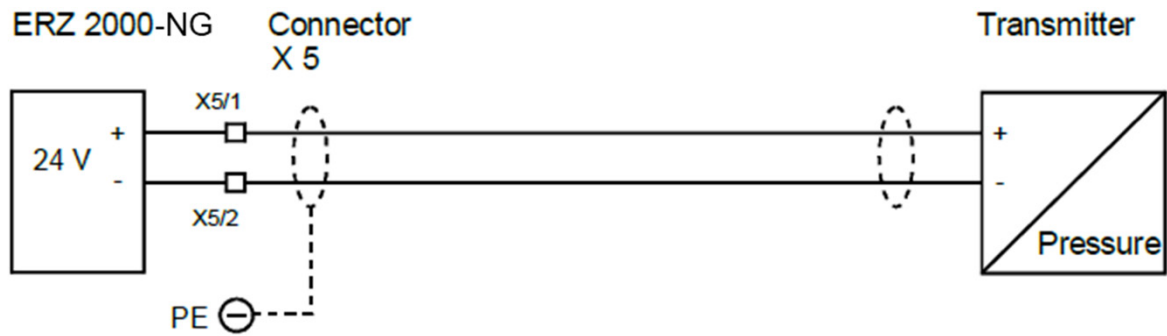
1 <sup>st</sup> step	Parameterize lower alarm limit parameter to 20 bar (assigned to the technical zero point 0 or 4 mA).	385
2 <sup>nd</sup> step	Parameterize upper alarm limit parameter to 70 bar (assigned to the technical end value 20 mA).	
3 <sup>rd</sup> step	Parameterize the offset correction parameter to 0	
4 <sup>th</sup> step	Apply a pressure signal, and/or test current input with calibrated measuring device and read the measured variable (display of measured pressure input in bar)	
5 <sup>th</sup> step	Determine the difference from: actually supplied measuring signal and displayed measured variable	
6 <sup>th</sup> step	Enter this difference as an offset in the offset correction parameter	
7 <sup>th</sup> step	Check the pressure measurement display	

The same procedure applies for all analog inputs.

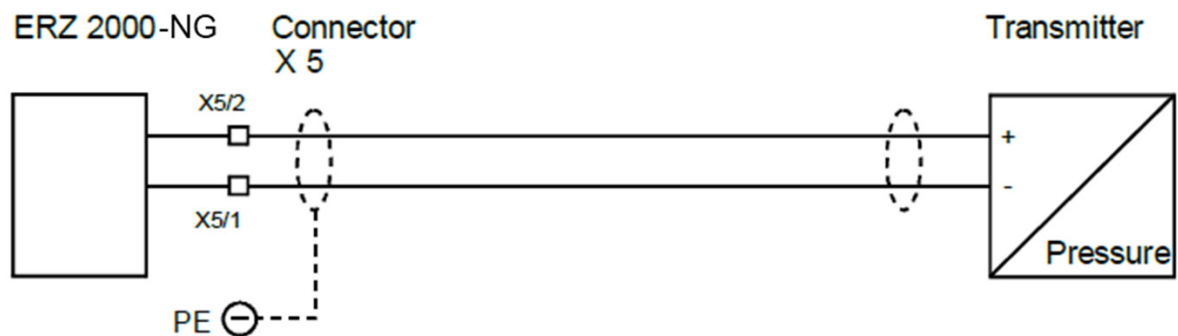
## E) Various circuit diagrams for inputs

### Input pressure measuring transducer

#### Passive current input (transmitter)

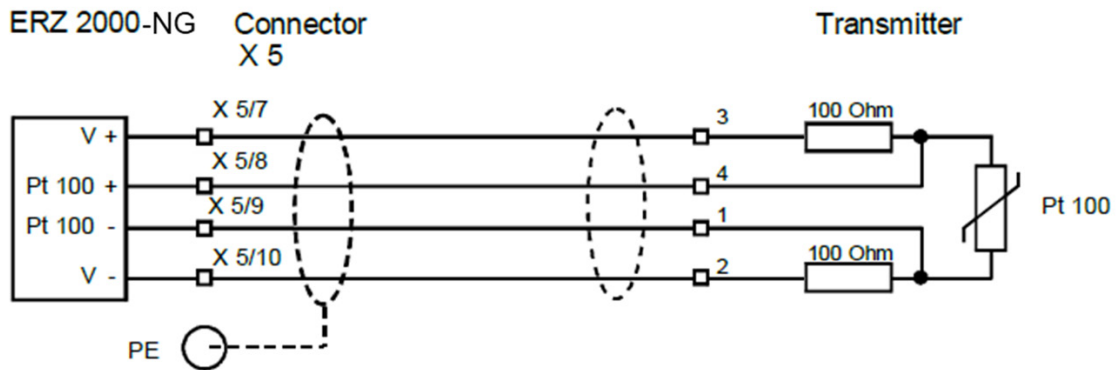


#### Active current input, e.g. 4-20mA



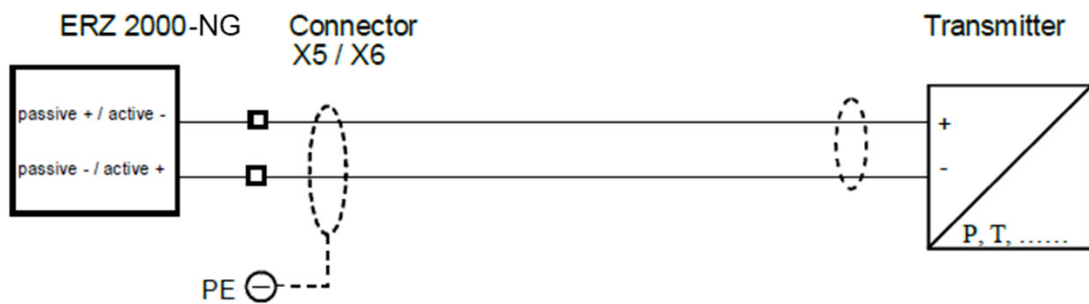
Temperature measuring transducer input

PT 100

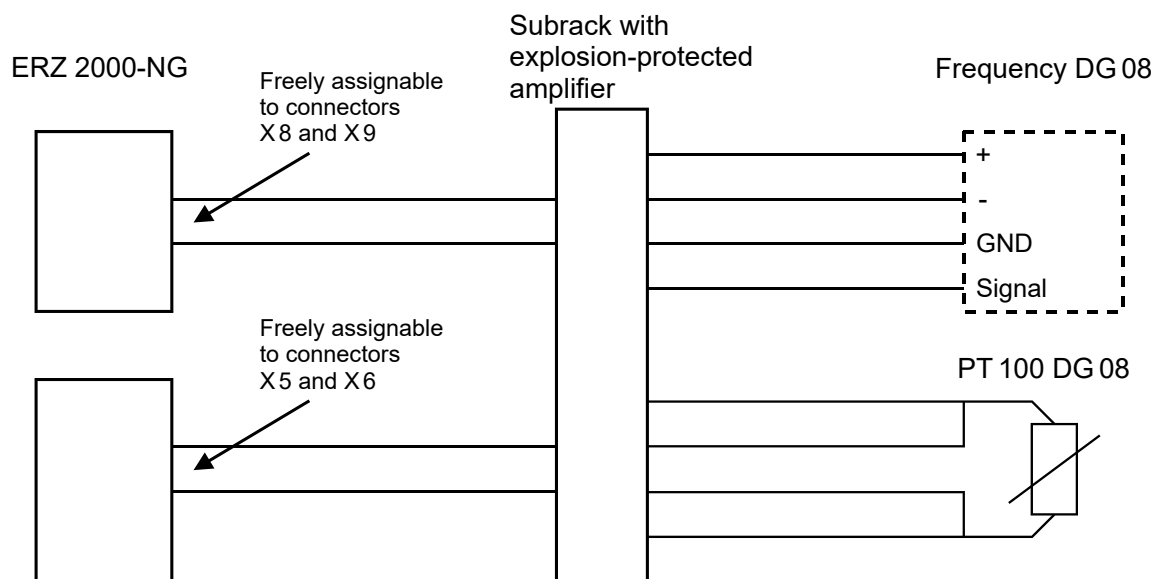


387

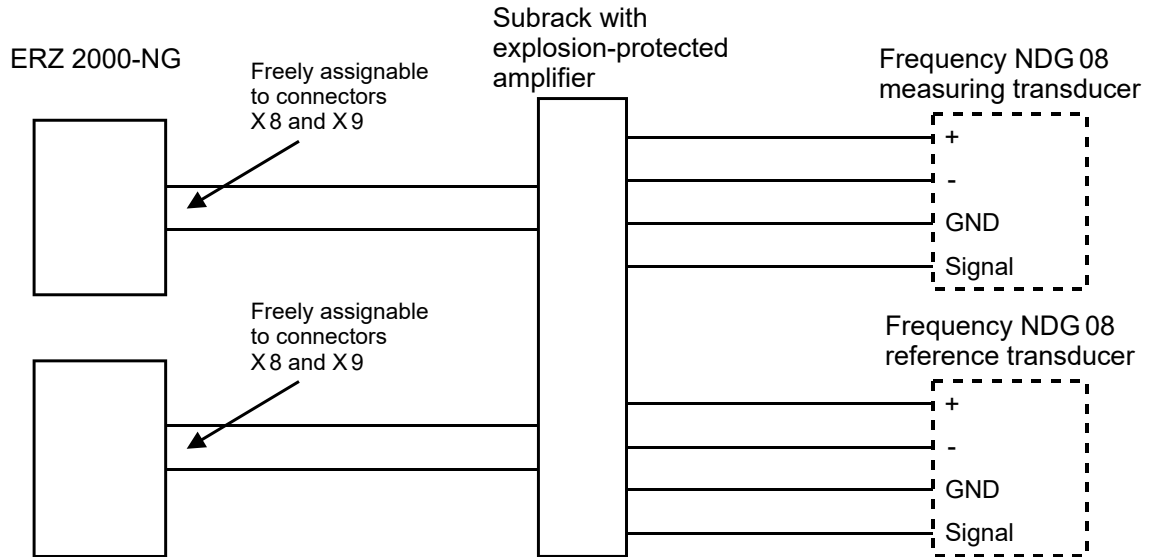
Active / passive reserve inputs, e.g. delta-p transmitter



Density measuring transducer input, type DG 08

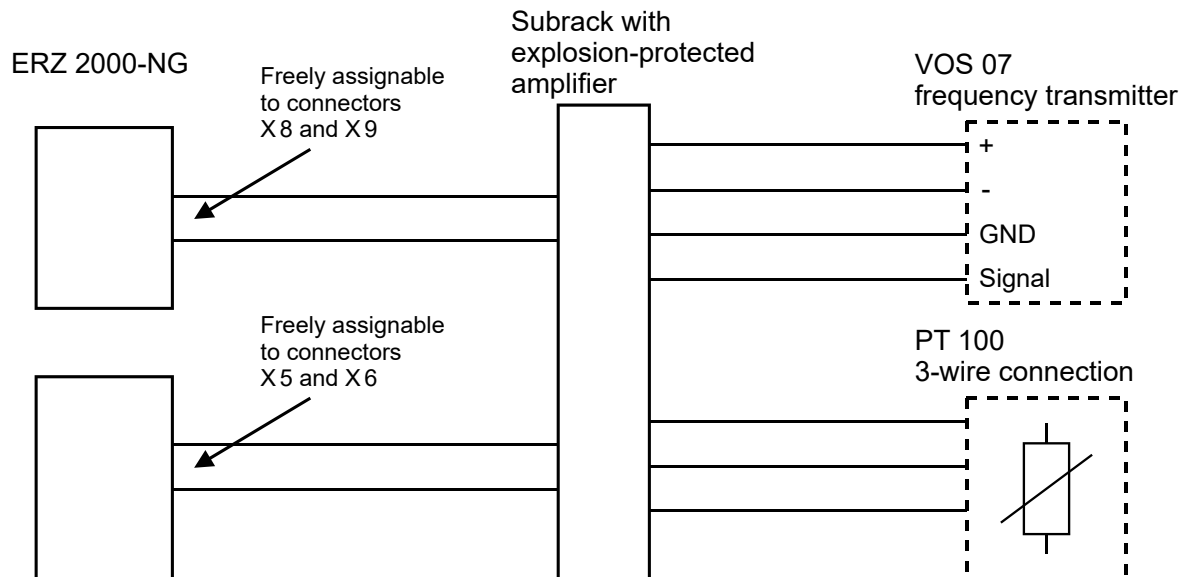


### Standard density measuring transducer input, type NDG 08



The frequency inputs 5, 6, 7 and 8 are multiplexed by the system. In the process, it must be ensured that the connection of the transmitters takes place gap-free i.e. in sequence.

### Measuring transducer for velocity of sound input, type VOS 07

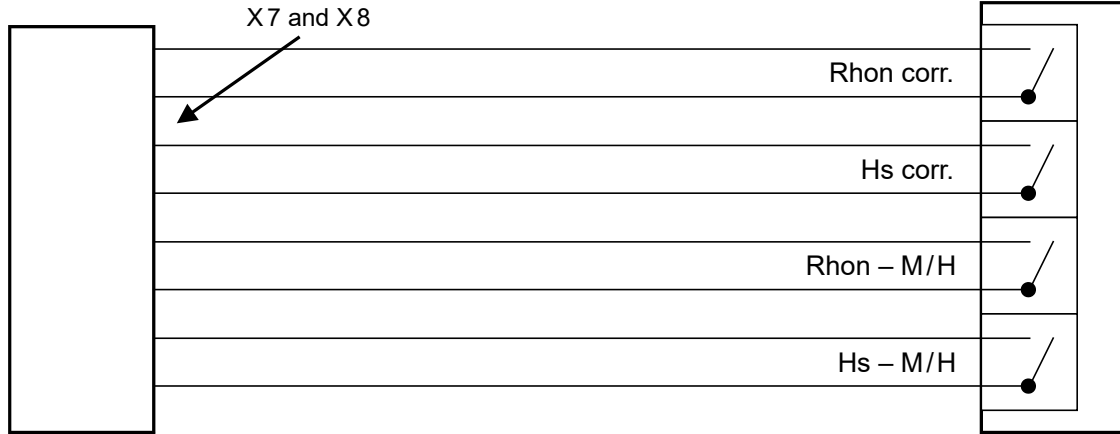


**Standard density/calorific value correction input**

ERZ 2000-NG

Freely assignable  
to connectors  
X7 and X8

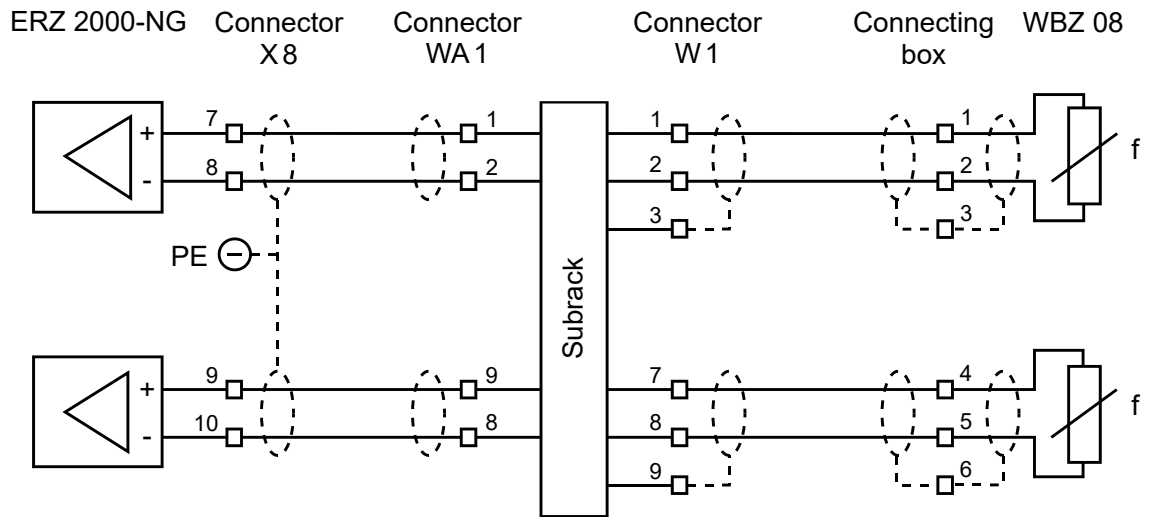
Set of switches



**Volume measurement input**

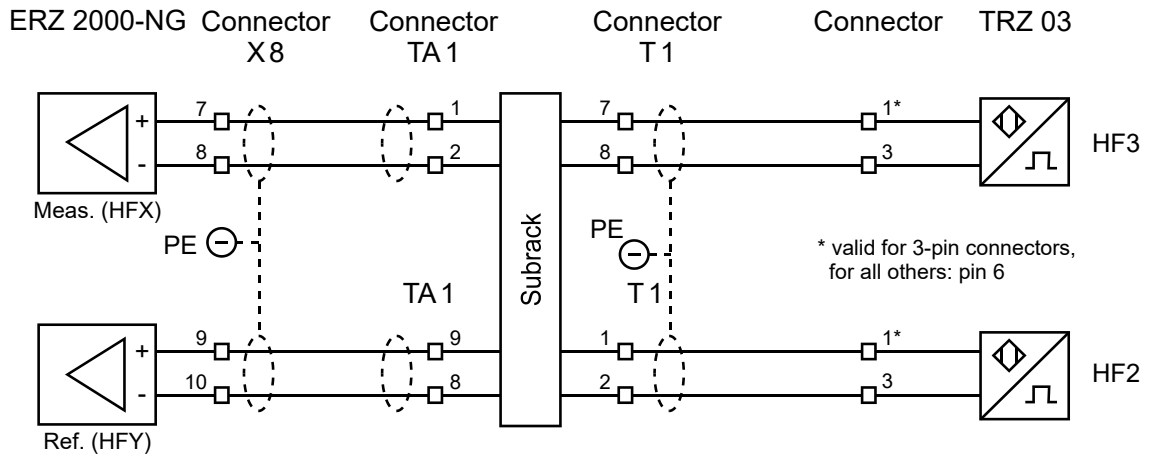
**Vortex gas meter**

390

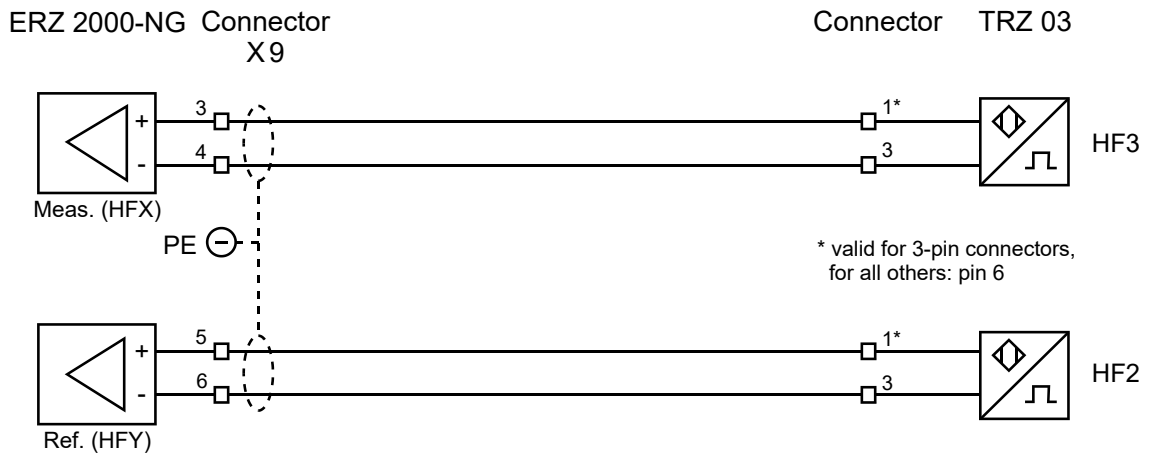




**Turbine meter**



**Turbine meter with integrated NAMUR separator stage (optional)**

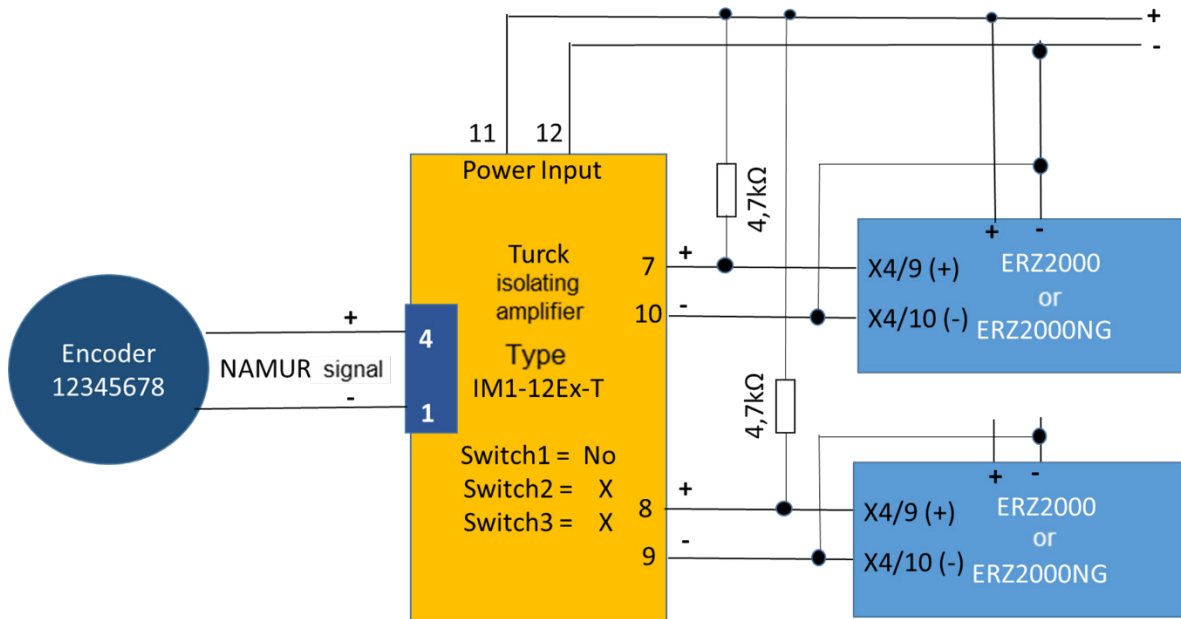


## Adaptation of an encoder on the ERZ2000-NG by means of switch amplifier

Preferred variants:

### Encoder wiring diagram for X4 – plug on ERZ2000-NG

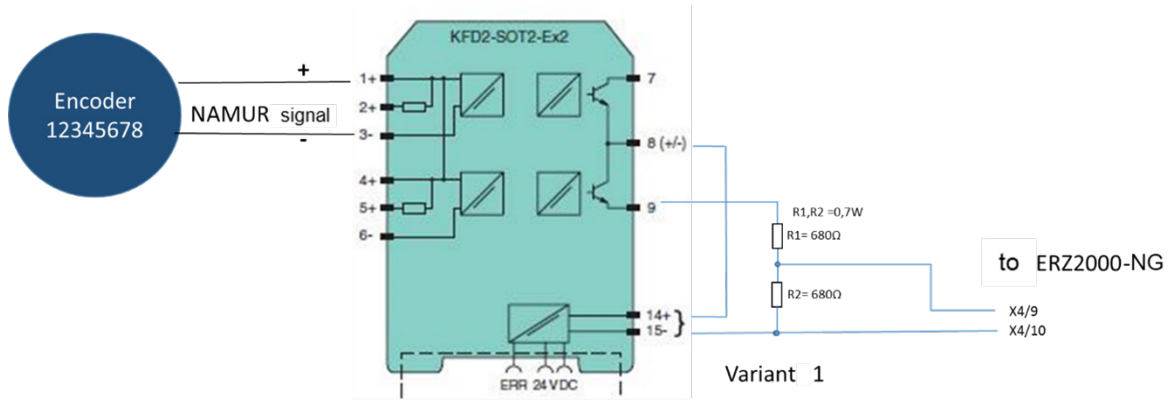
392



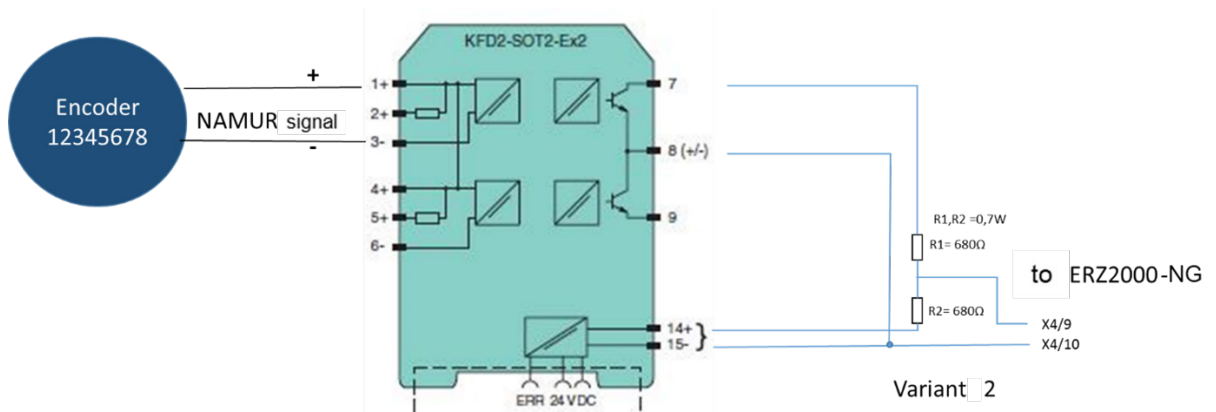
Connection of an encoder to an ERZ2000/ERZ2000-NG via a switch amplifier (e.g. TURK IM1-12Ex-T).

Alternatively, the following two variants can be used for a PF – switch amplifier:

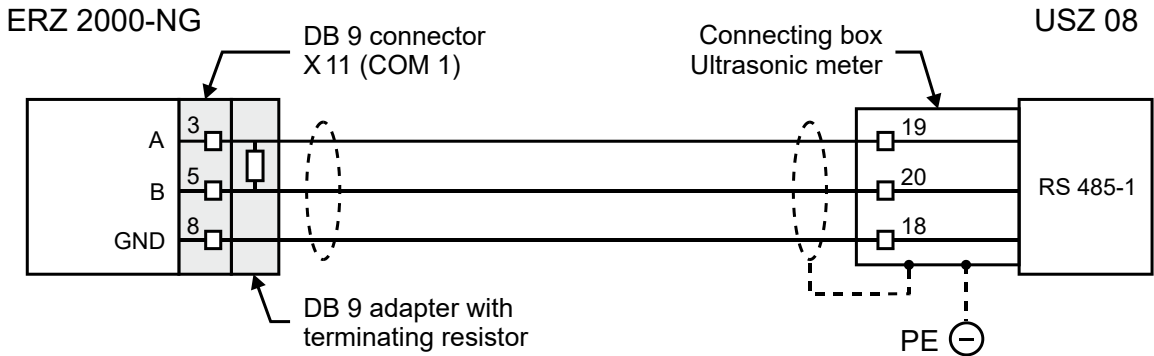
Positive-based wiring:



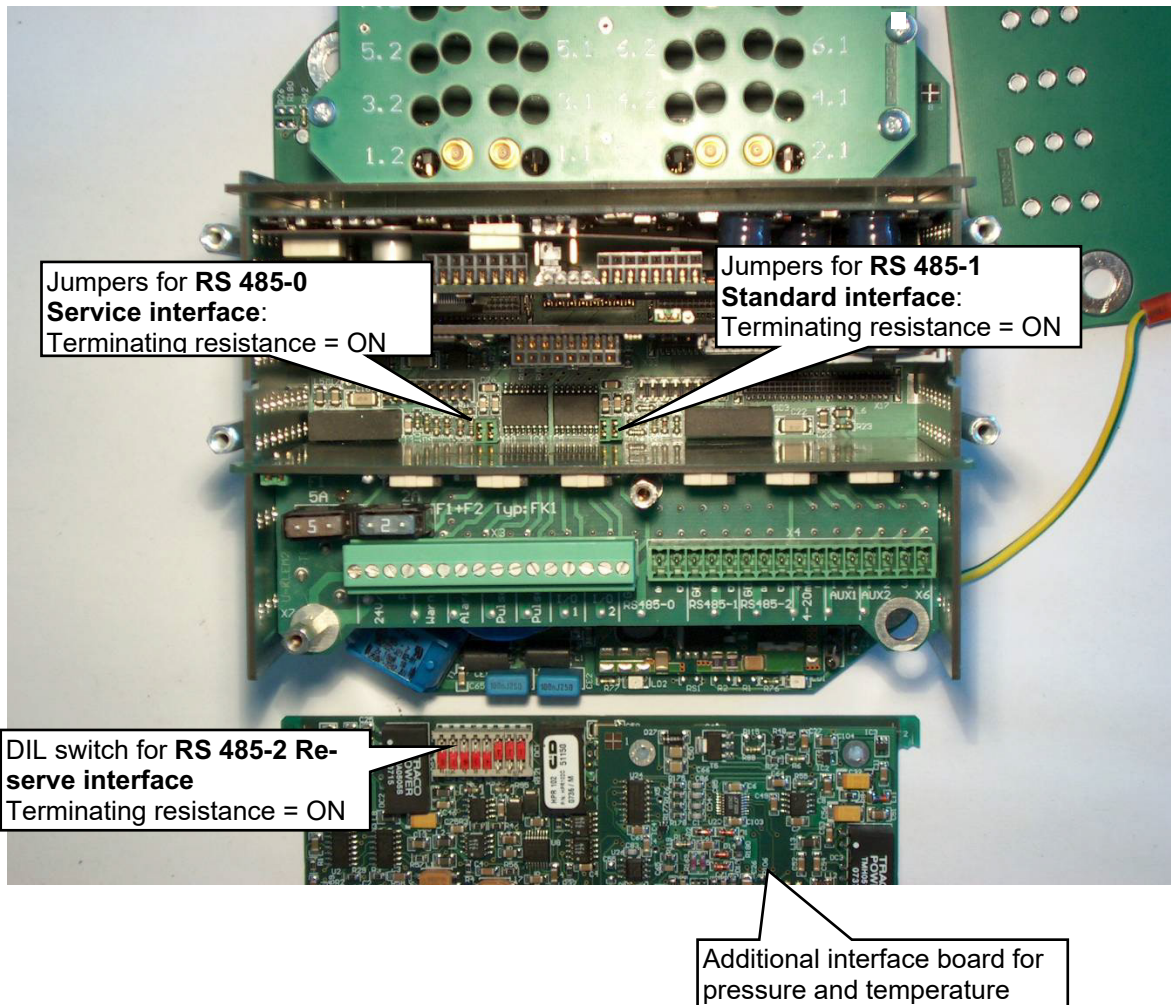
Ground-based wiring



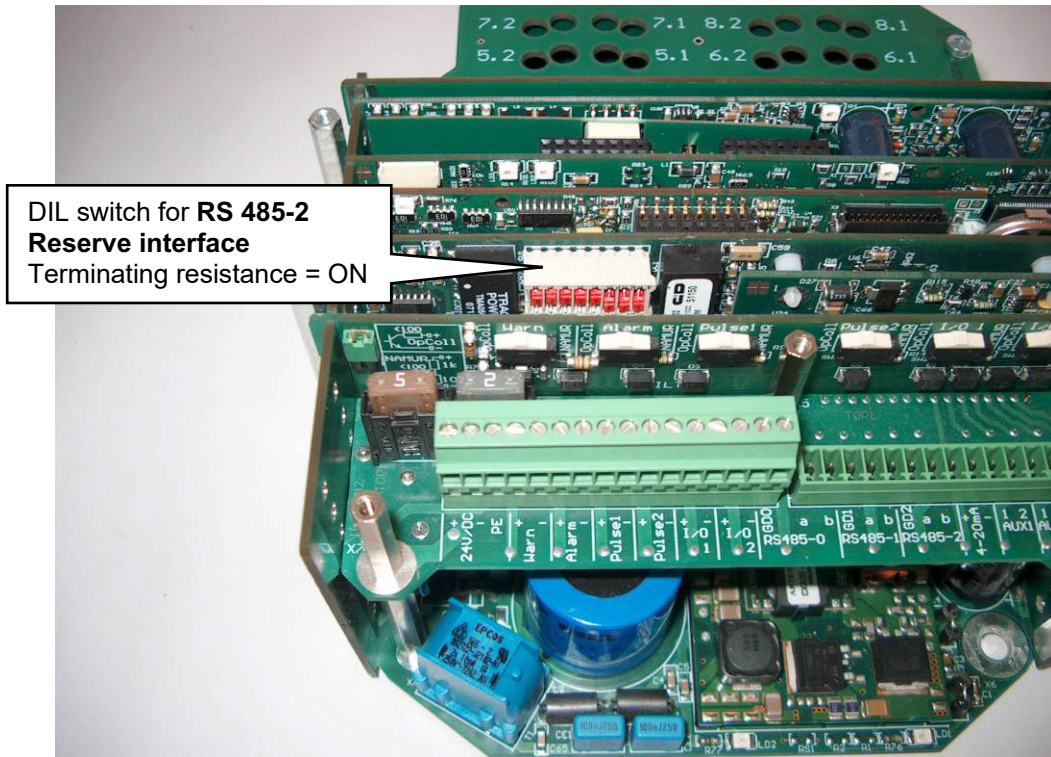
**Ultrasonic gas meter**



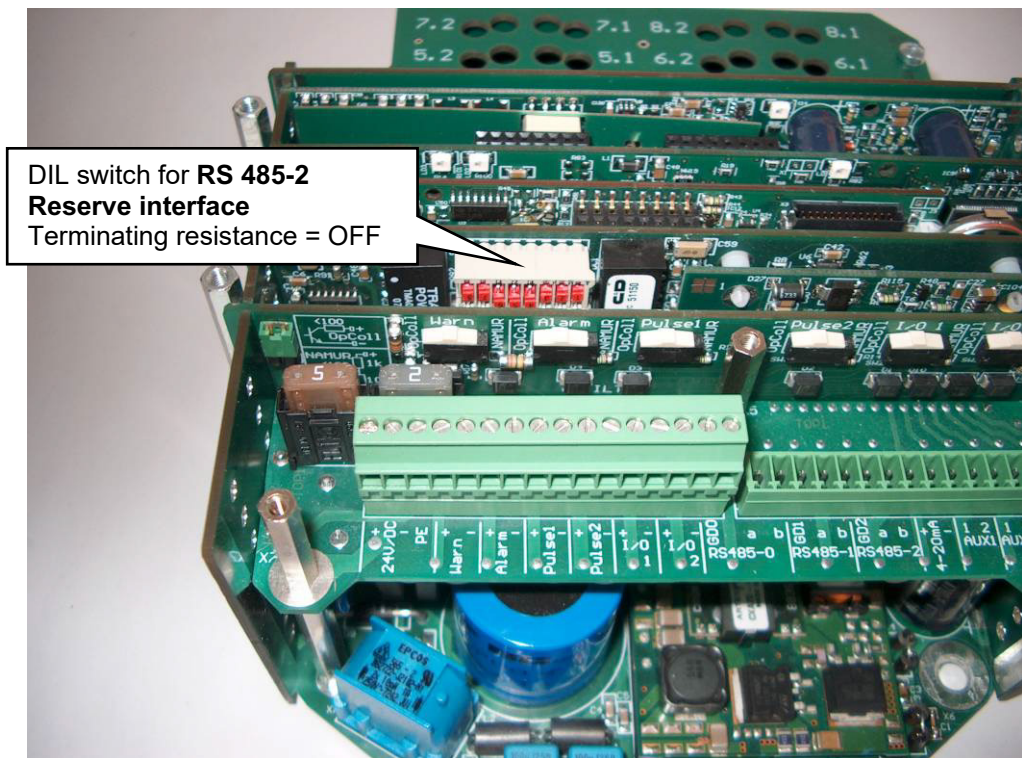
Supplementary to **ultrasonic gas meters**, the following figures show settings on the **USE-09** electronics of the **USM-GT400** or **USZ 08**, of the ultrasonic meter of RMG.



**Figure 276: USE-09 Electronics of the USM-GT400 or USZ 08**



**Figure 277: USE-09 Electronics of the USM-GT400 or USZ 08**



**Figure 278: USE-09 Electronics of the USM-GT400 or USZ 08**

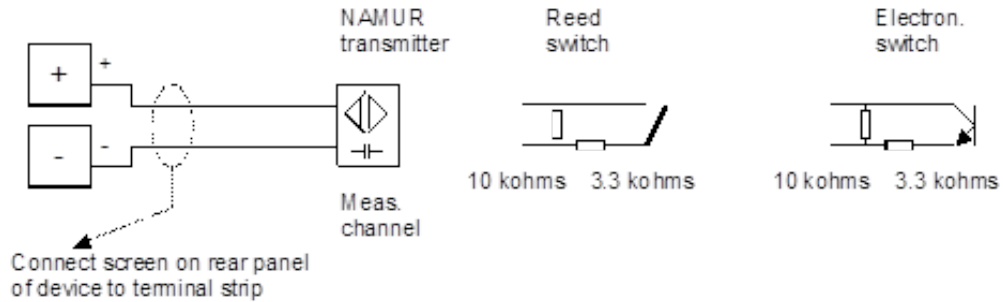
**Ex-input NAMUR signals**

**Connection options based on the example of the measuring input**

**Volume transmitter NAMUR sensor or switch with line monitoring**

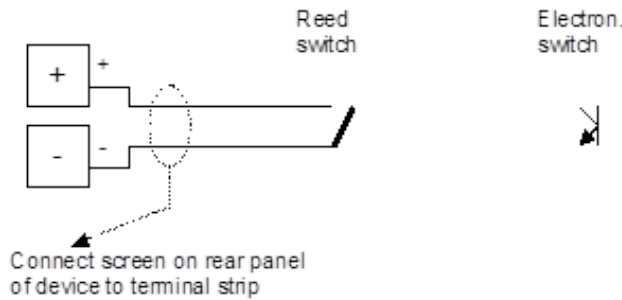
Selectable operating modes:

- Standard NAMUR => The card adapts to the standardized NAMUR levels
- RMG factory settings => The card adapts to the optimized levels for the TRZ 03
- Manual adjustment => The levels set can be adjusted manually



**Volume transmitter switch without line monitoring**

Reed switch or transistor / standard NAMUR setting



## F) Optional Ex input board

### F.1 Instructions for the installer

**Code:**

**Type:** EX1-NAMUR-2 / V1 or V2

397



II(2)G [Ex ia] IIC

**TÜV 06 ATEX 553139 X**

**Tamb = -20°C .... +60°C**

**Data: see EC Type approval certificate**

**Use:**

Use of the assembly takes place in combination with the device ERZ2000-NG only. The assembly is provided for galvanic isolation of MSR signals, such as 20 mA current loops or the adjustment and/or standardization of signals. The different intrinsically safe current circuits are provided to operate intrinsically safe field devices within explosion-prone areas. The applicable laws and directives for the use and/or planned use must be observed. Version V1 is the standard version for a 1-rail flow computer, version V2 is designed for a 2-rail flow computer (optional expansion level).

Multiple transmitters/sensors can be connected to the EX1-NAMUR-2 board.

- 2 volume transmitters, with pulse sensors similar to DIN 19234,
- 1 electronic totalizer (ENCO),
- 1 pressure transducer (4 to 20mA or HART),
- 1 temperature sensor (4 to 20mA or HART),
- optionally 1 temperature sensor (PT100 4-wire).

**Installation and commissioning in connection with Ex areas:**

Installation and commissioning must be carried out exclusively by specially trained and qualified personnel. The device is designed with protection rating IP20 in accordance with EN 60259 and appropriate measures must be taken in unfavorable environmental conditions that exceed contamination degree 2. External heating due to solar radiation or other heat sources must be prevented. The installation of intrinsically safe current circuits must be carried out according to the applicable installation regulations. For connection of intrinsically safe field devices with the intrinsically safe current circuits of the corresponding devices of the ERZ2000-NG,

---

the highest values of the field device and the corresponding device must be observed in consideration of explosion protection.

The EC conformity certificate and/or EC type approval certificate must be observed. Compliance with any "Special conditions" contained therein is especially important.

---

398

---

---

---

**Commissioning:**

The connector plug must be installed correctly in the mating plug intended for this purpose and secured mechanically. Operation must take place in a completely enclosed housing.

**Service / maintenance:**

The fuses in the devices must only be replaced when in a de-energized state. Repairs of the device must be carried out exclusively by RMG Messtechnik GmbH.

**Disassembly:**

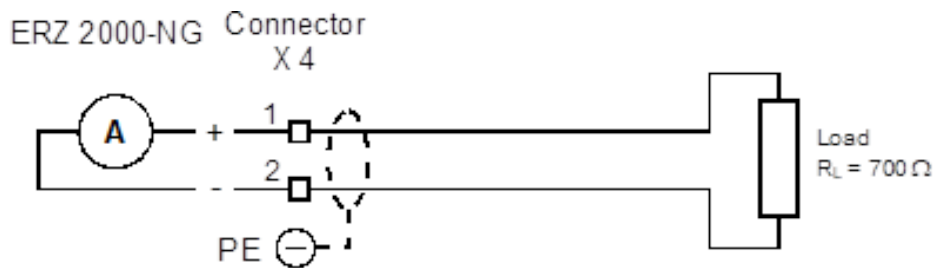
When disassembling, it must be ensured that the sensor cable does not come into contact with other live parts. Appropriate protective measures must be taken.



## G) Various circuit diagrams for outputs

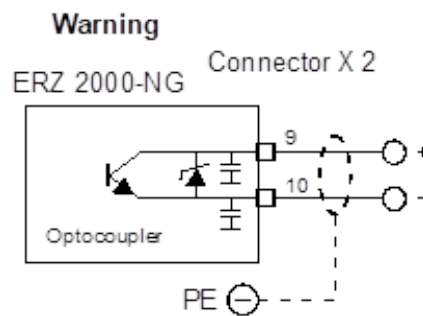
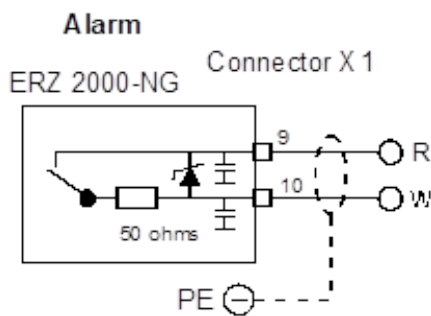
### Analog output

Example: Analog output 1

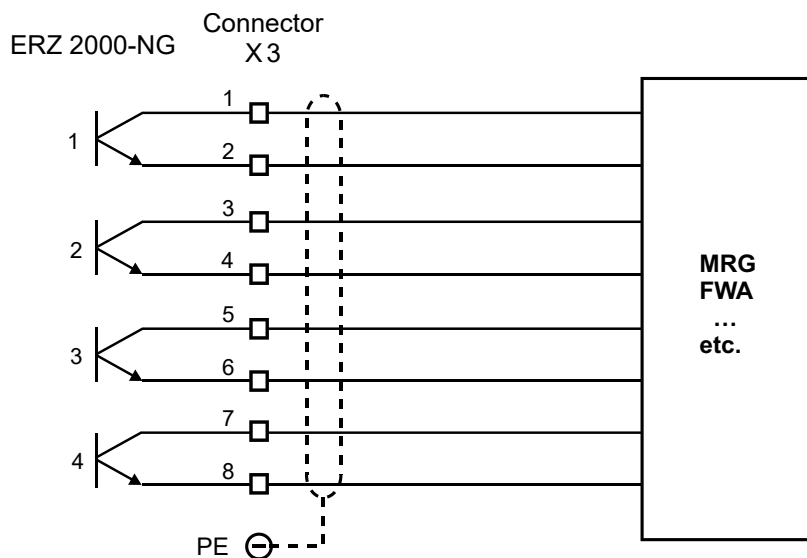


399

### Alarm, warning



### Pulse outputs (1-4) internal connection similar to warning



## H) Vo digital totalizer

The data transfer between gas meter and flow computer takes place via a shielded pair of twisted wires. The electrical characteristic data conforms to DIN 19234 (NAMUR). The data transmission is unidirectional from the totalizer to the flow computer and reactionless.

### Layer 1 (bit transmission layer)

The cable used for the transmission must satisfy the requirements for intrinsically safe circuits. A shielded 2-wire twisted cable must be used. The Shielding must be grounded on the side of the flow computer. In order to ensure that the ignition protection type is intrinsically safe on the primary side and the end device, the following guideline limit values should not be exceeded:

Voltage  $U_0 = 13.5 \text{ V}$     Current  $I_k = 15 \text{ mA}$     Power  $P = 210 \text{ mW}$

Exact current, voltage and power values are indicated on the type test certificate.

The electrical level on the connecting cable satisfies DIN 19234 (NAMUR). The supply takes place with  $U_0 = 8 \text{ V}$  and  $I_k = 8 \text{ mA}$ . The data transmission takes place asynchronously at a rate of 2400 bit/s. The level for log. 1 (MARK) must be  $> 2.1 \text{ mA}$ , the level for log. 0 (SPACE)  $< 1.2 \text{ mA}$ .

### Layer 2 (backup layer)

The data transmission takes place character-by-character. Each character consists of 1 start bit, 7 data bits, even parity and 1 stop bit. Data frames are formed from these characters, with the following configuration:

Start character	<US>	Data character, partly separated by <US>	<FS>	<BCC>	<CR>	<LF>
-----------------	------	--	------	-------	------	------

Start character	all lower-case letters from a to z
<US>	separates the start character from the subsequent data characters
<FS>	closes the data frame as an end identifier
<BCC>	Block check character Is formed starting from and including the start character until and including <FS> as even horizontal parity over data bits 0 to 6 and supplements even character parity.
<CR> and <LF>	are provided for unique separation of successive data frames.

The size of a data frame starting from and including the start character until and including <LF> is a maximum of 64 characters.

**Layers 3 to 6:** omitted

### Layer 7 (processing layer)

The following data frames have been specified thus far:

Data frame a "Totalizer status" obligatory:

Contents	Meaning	
a <US>	Start character lower-case <b>a</b> , data frame identifier " <b>Totalizer status</b> "	
zzzzzzzz <US>	Totalizer status max. 14 digits as ASCII decimal number, <b>no</b> leading zero suppression	
ww <US>	Significance of the totalizer status, max. 2 digits, optional algebraic sign (+ or -) and power of ten as ASCII decimal number <sup>1</sup>	
eee<US>	Unit of the totalizer status, max. 3 digits, as text field <sup>2</sup>	401
s<FS>	Totalizer status, exactly 1 byte, value range 0x30 to 0x3F, 0x30 means no errors <sup>3</sup>	

#### Additional comments:

- <sup>1</sup> The significances 0, +0 and -0 have the same meaning and are permissible
- <sup>2</sup> Typically, M3 is used as a unit of the totalizer status. Other volume or mass units are also permissible.
- <sup>3</sup> The totalizer status permits four error messages that are independent of each other. Correct totalizer status are only expected for the end device with status = 0x30.

#### Data frame b "Type plate" optional:

Contents	Meaning
b <US>	Start character lower-case <b>b</b> , data frame identifier " <b>Type plate</b> "
HHH <US>	Manufacturer identification, exactly 3 digits, capital letters <sup>1</sup>
TTTTT <US>	Device type / meter size max. 6 digits <sup>2</sup>
SSSSSSSS <US>	Serial number of the meter, max. 9 digits <sup>2</sup>
JJJ <US>	Year of manufacture of the meter, exactly 4 digits, as ASCII decimal number <sup>3</sup>
VVVV <FS>	Software version of the electronics, max. 4 digits <sup>2</sup>

#### Additional comments:

- <sup>1</sup> The manufacturer identification consists of the first 3 letters of the company name entered in the commercial register.
- <sup>2</sup> The fields are declared as free text fields for informational purposes only.
- <sup>3</sup> The value range extends from 19(50) to 20(49).

An exchange of at least one data frame per second is required on layer 2 according to specifications in order to maintain the connection between the primary device and end device. In this case, data frame a "Totalizer status" has priority.

## I) Examples for use of the revision switch

### Tests for totalizers connected in a series

Totalizers run and are identified in the archive, output pulses stop

#### ED Parameter access

Access Line	Designation	Value	Unit	Variable
B	1	Revision mode	Revision	<a href="#">revisMode</a>
C	2	Codeword 1	9999	<a href="#">code1</a>
C	3	Codeword 2	9999	<a href="#">code2</a>
A *	4	Current access	<b>Super user</b>	<a href="#">actAccess</a>
X	5	service mode	Yes	<a href="#">serviceMod</a>
D	6	Current access	Super user	<a href="#">actAccess2</a>
D	8	Expired	1025 s	<a href="#">xsCur</a>
B	9	Max. opening time	1800 s	<a href="#">xsMax</a>
D	10	act. Op./Rev.	Operation	<a href="#">revisBtr</a>
D	11	Revision contact	OFF	<a href="#">ktkRevis</a>
B	12	Source revision ctc	OFF	<a href="#">kzoRevis</a>
S	13	total. in revision	running	<a href="#">zwRevMod</a>
S	14	Temp. at revision	live value	<a href="#">tRevMod</a>
S	15	Press. at revision	live value	<a href="#">pRevMod</a>

Enter Cancel Load defaults Refresh

Pressure and temperature measurement continue running for the conversion

S	14	Temp. at revision	retained value	<a href="#">tRevMod</a>
S	15	Press. at revision	retained value	<a href="#">pRevMod</a>

Enter Cancel Load defaults Refresh

Pressure and temperature measurement are retained for the conversion

**Figure 279: Series connection revision mode**

The revision measurement values are in coordinate **AB24 Base value** and **AC24 Base value**.

Tests for simulation, all totalizers stop

**ED Parameter access**

Access Line	Designation	Value	Unit	Variable
B 1	Revision mode	Revision		revisMode
C 2	Codeword 1	9999		code1
C 3	Codeword 2	9999		code2
A * 4	Current access	<b>Super user</b>		actAccess
X 5	service mode	Yes		serviceMod
D 6	Current access	Super user		actAccess2
D 8	Expired	1025	s	xsCur
B 9	Max. opening time	1800	s	xsMax
D 10	act. Op./Rev.	Operation		revisBtr
D 11	Revision contact	OFF		ktkRevis
B 12	Source revision ctc	OFF		kzoRevis
S 13	total. in revision	At rest		zwRevMod
S 14	Temp. at revision	live value		tRevMod
S 15	Press. at revision	live value		pRevMod

Enter Cancel Load defaults Refresh

403

**Figure 280: Tests for simulation revision mode**

Tests for totalizers connected in a series

Totalizers run and are identified in the archive, output pulses stop.

**ED Parameter access**

Access Line	Designation	Value	Unit	Variable
B 1	Revision mode	Rev. via contact		revisMode
S 13	total. in revision	running		zwRevMod
S 14	Temp. at revision	live value		tRevMod
S 15	Press. at revision	live value		pRevMod

**Figure 281: Revision via contact: Tests for totalizers connected in a series**

### Tests for simulation

activated via external contact, all totalizers stop.

#### ED Parameter access

Access Line	Designation	Value	Unit	Variable
B 1	Revision mode	Rev. via contact ▾		<a href="#">revisMode</a>
C 2	Codeword 1	9999		<a href="#">code1</a>
C 3	Codeword 2	9999		<a href="#">code2</a>
A * 4	Current access	<b>Super user</b>		<a href="#">actAccess</a>
X 5	service mode	Yes ▾		<a href="#">serviceMod</a>
D 6	Current access	Super user		<a href="#">actAccess2</a>
D 8	Expired	1025	s	<a href="#">xsCur</a>
B 9	Max. opening time	1800	s	<a href="#">xsMax</a>
D 10	act. Op./Rev.	Operation		<a href="#">revisBtr</a>
D 11	Revision contact	OFF		<a href="#">ktkRevis</a>
B 12	Source revision ctc	OFF ▾		<a href="#">kzoRevis</a>
S 13	total. in revision	At rest ▾		<a href="#">zwRevMod</a>
S 14	Temp. at revision	live value ▾		<a href="#">tRevMod</a>
S 15	Press. at revision	live value ▾		<a href="#">pRevMod</a>

Enter Cancel Load defaults Refresh

Pressure and temperature measurement continue running for the conversion

S 13	total. in revision	At rest ▾		<a href="#">zwRevMod</a>
S 14	Temp. at revision	retained value ▾		<a href="#">tRevMod</a>
S 15	Press. at revision	retained value ▾		<a href="#">pRevMod</a>

Enter Cancel Load defaults Refresh

Pressure and temperature measurement are retained for the conversion

**Figure 282: Revision via contact: Tests for simulation**

#### Note

The monitoring of limits is deactivated, all hardware monitors, such as cable break, etc. remain active and influence the base value.

The hold value is not influenced

## J) Appendix for bus systems

### J.1 DSfG bus

#### .J.1.1 Literature for the DSfG bus

The digital interface for gas measurements (German: *Digitale Schnittstelle für Gasmessgeräte*) abbreviated as the DSfG is described comprehensively in the following documents:

405

- G485 Technical Rules, Work Sheet, September 1997
- Gas Information No. 7, 3rd Revision 04/2007, Technical Specifications for DSfG Implementation
  - Part 1 Basic Specifications
  - Part 2 Mapping of the DSfG on IEC 60870-5-101/104
  - List of DSfG Data Elements

Issuer:

DVGW  
*Deutscher Verein des Gas- und Wasserfaches e.V.*  
Postfach 140362  
53058 Bonn, Germany  
Telephone +49 (0)228/9188-5  
Fax +49 (0)228/9188-990

The documents can be ordered in hard copy from:

Wirtschafts- und Verlagsgesellschaft Gas und Wasser mbH  
Postfach 140151  
53056 Bonn, Germany

They can be downloaded in electronic format from:

[www.dvgw.de/gas/messtechnik-und-abrechnung/gasmessung/](http://www.dvgw.de/gas/messtechnik-und-abrechnung/gasmessung/)

#### .J.1.2 Cross-comparison via DSfG

Volume at measurement conditions, volume at base conditions, temperature and pressure of two computers should be compared via DSfG. A computer pair, e.g. with the addresses A and B, is assigned a reciprocal partner device (B and A). The parameterization takes place with **IC01 Corrector address** and **IO10 Partners address**. Each computer with an address smaller than the address of the partner adopts the master role in the exchange of data. The slave is passive in this regard.

The mater generates a data transmission telegram with DFO = Y, i.e. an answer is expected, according to a time event that is adjustable with **IO11 survey period**. Values of Vm, Vb, T and P, as well as the determination time period are provided in the data part. Vm and Vb are independent totalizers which can be operated in-

dependently of disturbance and billing mode. The counters are set to zero after transmission of a telegram and then begin counting up incrementally again.  $V_m$  divided by time has the meaning of a  $Q_m$  flow.

The slave does not react to a time event, even if this is parameterized. It answers when it receives a data transmission telegram with  $DFO = Y$  with a telegram with  $DFO = N$ , i.e. do not send an answer back. Then, its values  $V_m$ ,  $V_b$ ,  $T$  and  $p$  are available in the data part of this telegram. The data is exchanged in this manner.

In both devices, *my* data and *its* data arise for each data set. A consecutive number sent with the data is used for synchronization.

If the data is valid, the deviations are calculated as percentages. With  $V_m$  and  $V_b$  the deviations are not determined by  $V_m$  and  $V_b$  themselves; instead, they are determined from *my*  $V_m$  divided by *my* time period and *its*  $V_m$  divided by *its* time period, i.e. on the basis of flows.

#### Example for $V_m$ and $Q_m$

*My* flow rate:  $Q_{m\_m} = dV_{m\_m} / dt\_m$

*Its* flow rate:  $Q_{m\_it} = dV_{m\_it} / dt\_it$

Percent deviation calculated from the example of the master

$V_m$  dev.:  $(Q_{m\_it} - Q_{m\_m}) / Q_{m\_m}$

In order to ensure that same deviation values arises for the master and slave, the formulae are implemented asymmetrically, i.e. *my* and *its* are exchanged.

The deviations are checked for an adjustable maximum value in each case. If the value is exceeded, corresponding notice messages are generated (no alarm, no warning). The results and the exchanged data are archived in archive group 7 and can be retrieved via DSfG.

This topic is covered in the coordinate system of the ERZ2000-NG in menu **IO DSfG tandem counter comparison**



**IO DSfG tandem counter comparison**

Access	Line	Designation	Value	Unit	Variable
D	1	Status	asynchronous		<a href="#">STlmw</a>
D	2	T dev. (K)	0.000	%	<a href="#">Ttnd</a>
D	3	P deviation	0.000	%	<a href="#">Ptnd</a>
D	4	dVb/dt dev.	0.000	%	<a href="#">VNtnd</a>
D	5	dVm/dt dev.	0.000	%	<a href="#">VBtnd</a>
D	6	period deviation	0.000	%	<a href="#">ZTnd</a>
B	10	Partners addr.	OFF		<a href="#">tandAdr</a>
B	11	survey period	OFF		<a href="#">tandZyk</a>
B	12	T perm. dev.	10.000	%	<a href="#">TtndMx</a>
B	13	P perm. dev.	10.000	%	<a href="#">PtndMx</a>
B	14	Vb perm.dev.	10.000	%	<a href="#">VNtndMx</a>
B	15	Vm perm.dev.	10.000	%	<a href="#">VBtndMx</a>
D	20	Own temperature	0.00	°C	<a href="#">Tmy</a>
D	21	Own pressure	0.000	bar	<a href="#">Pmy</a>
D	22	Own survey period	.000	s	<a href="#">ZTmy</a>
D	23	Own base volume	.000	m3	<a href="#">VNmy</a>
D	25	Own oper. volum.	.000	m3	<a href="#">VBmy</a>
D	29	Own running no.	0		<a href="#">Omy</a>
I	30	Foreign temperat.	0.00	°C	<a href="#">This</a>
I	31	Foreign pressure	0.000	bar	<a href="#">Phis</a>
I	32	For. surv. period	.000	s	<a href="#">ZThis</a>
I	33	Foreign base vol.	.000	m3	<a href="#">VNhis</a>
I	34	Foreign oper.vol.	.000	m3	<a href="#">VBhis</a>
I	39	Foreign run.no.	0		<a href="#">Ohis</a>
D	40	act. survey period	.000	s	<a href="#">ZTlmw</a>
D	41	act. base volume	.000	m3	<a href="#">VNlmw</a>
D	42	act. oper. volume	.000	m3	<a href="#">VBlmw</a>

Enter
Cancel
Load defaults
Refresh

**Figure 283: Menu: IO DSfG tandem counter comparison**

The coordinates are largely self-explanatory.

**Note**

**Additional DSfG-relevant points:**

- Alarm and warning messages / DSfG distinctions
- Electrical connections / DSfG bus / DSfG plug assignment
- Electrical connections / DSfG bus / DSfG bus termination

## J.2 Modbus

### .J.2.1 Summarized fault messages

Register 474 (and 9118) contain summarized fault messages in the form of a bit pattern. Only alarms are relevant. Warning messages and notices are not considered.

Bit	Symbol	Meaning	
0	dP	Effective pressure	LSB
1	GC	Gas composition	
2	T	Temperature	
3	P	Pressure	
4	Vn	Volume at base cond.	
5	Vb	Volume at meas. cond.	
6	n.u.	not used	
7	n.u.	not used	
8	n.u.	not used	
9	n.u.	not used	
10	n.u.	not used	
11	n.u.	not used	
12	n.u.	not used	
13	n.u.	not used	
14	n.u.	not used	
15	n.u.	not used	MSB

All alarms are investigated in the ERZ2000 according to logical associations and displayed as collective alarms in register 474 in a special bit.

**Bit 0:** Delta P alarms  
**Bit 1:** Gas composition alarms  
**Bit 2:** Temperature alarms  
**Bit 3:** Pressure alarms  
**Bit 4:** Alarms associated with the volume at base cond.  
**Bit 5:** Alarms associated with the volume at meas. cond.

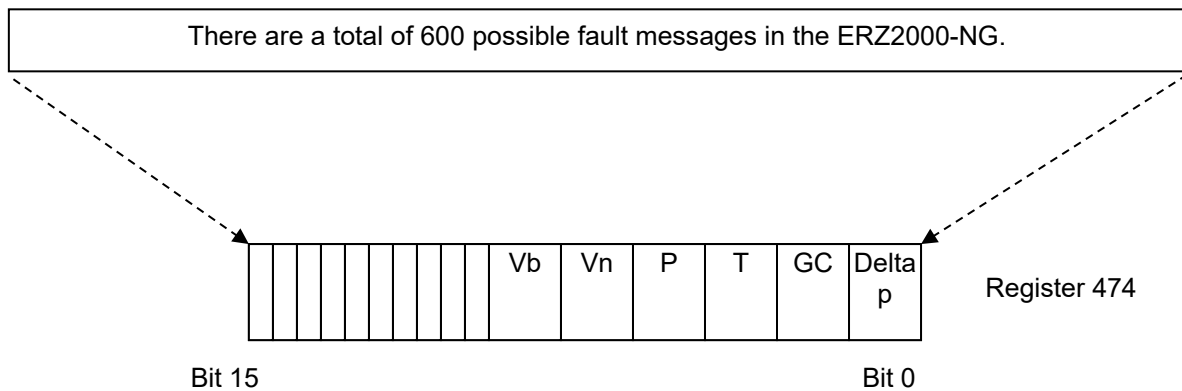
The same bit pattern is also used in the specific 9000 range in register 9118.

#### Examples

00000000 00000000 = no alarm pending

00000000 00010000 = an alarm is pending which only has an influence on the volume at base conditions

00000000 00010100 = an alarm is pending which has an influence on the temperature and volume at base conditions



**Error table with effect in register 474**

No.	Category	Error number	Short text	Long text	Bit string 474
0	A	00-0	T failure	Temperature failure	Vn+T
1	A	00-1	T< LL alarm	Temperature below lower alarm limit value	Vn+T
2	A	00-2	T> UL alarm	Temperature above upper alarm limit value	Vn+T
3	A	00-3	T-jump	Temperature gradient above upper maximum	Vn+T
7	A	01-0	TS failure	Temperature failure VOS	Vn
8	A	01-1	TS<Alarm LL	Temperature VOS below lower alarm limit value	Vn
9	A	01-2	TS>Alarm UL	Temperature VOS above upper alarm limit value	Vn
10	A	01-3	TS-jump	VOS temperature gradient above maximum	Vn
14	A	02-0	TD failure	Density transmitter temperature failure	Vn
15	A	02-1	TD<Alarm-LL	Density transmitter temp. below lower alarm limit value	Vn
16	A	02-2	TD>Alarm-UL	Density transmitter temp. above upper alarm limit value	Vn
17	A	02-3	TD-jump	Density transmitter temp. gradient above upper maximum	Vn
21	A	03-0	Pa failure	Absolute pressure failure	Vn+P
22	A	03-1	Pa<LL alarm	Absolute pressure below lower alarm limit value	Vn+P
23	A	03-2	Pa>UL alarm	Absolute pressure above upper alarm limit value	Vn+P
24	A	03-3	Pa-jump	Absolute pressure gradient above upper maximum	Vn+P
28	A	04-0	Rn failure	Nominal density failure	Vn+GC
29	A	04-1	Rn<LL alarm	Nominal density below lower alarm limit value	Vn+GC
30	A	04-2	Rn>UL alarm	Nominal density above upper alarm limit value	Vn+GC
31	A	04-3	Rn-jump	Standard density gradient above upper maximum	Vn+GC
35	A	04-7	HW pulse comp.	Hardware pulse comparison initiated	Vb+Vn
38	A	05-0	Rb failure	Operating density failure	Vn
39	A	05-1	Rb<Alarm-LL	Operating density below lower alarm limit value	Vn
40	A	05-2	Rb>Alarm-UL	Operating density above upper alarm limit value	Vn
41	A	05-3	Rb-jump	Operating density gradient above upper maximum	Vn
44	A	05-6	Rb-miscalc.	faulty operating density calculation	Vn+GC
46	A	05-8	Vo Alarm	Vo Alarm error effect failure	Vb+Vn
48	A	06-0	Ho Failure	Calorific value failure	Vn+GC
49	A	06-1	Ho<LL alarm	Calorific value below lower alarm limit value	Vn+GC
50	A	06-2	Ho>LL alarm	Calorific value above upper alarm limit value	Vn+GC
51	A	06-3	Ho-jump	Calorific value gradient above upper maximum	Vn+GC
55	A	07-0	CO2 failure	Carbon dioxide failure	Vn+GC
56	A	07-1	CO2<LL alarm	Carbon dioxide below lower alarm limit value	Vn+GC
57	A	07-2	CO2>UL alarm	Carbon dioxide above upper alarm limit value	Vn+GC
58	A	07-3	CO2-jump	Carbon dioxide gradient above upper maximum	Vn+GC

62 A	08-0	VSO failure	VOS at meas. cond. failure	Vn
63 A	08-1	VSO<Alarm-LL	VOS at meas. cond. below lower alarm limit value	Vn
64 A	08-2	VSO>Alarm-UL	VOS at meas. cond. above upper alarm limit value	Vn
65 A	08-3	VSO-jump	VOS at meas. cond. gradient above maximum	Vn
69 A	09-0	H2 failure	Hydrogen failure	Vn+GC
70 A	09-1	H2<LL alarm	Hydrogen below lower alarm limit value	Vn+GC
71 A	09-2	H2>UL alarm	Hydrogen above upper alarm limit value	Vn+GC
72 A	09-3	H2-jump	Hydrogen gradient above upper maximum	Vn+GC
80 A	12-0	VSN failure	VOS at base cond. failure	Vn
81 A	12-1	VSN<Alarm-LL	VOS at base cond. below lower alarm limit value	Vn
82 A	12-2	VSN>Alarm-UL	VOS at base cond. above upper alarm limit value	Vn
83 A	12-3	VSN-jump	VOS at base cond. gradient above maximum	Vn
87 A	13-0	Pu failure	Overpressure failure	Vn+P
88 A	13-1	Pu<Alarm-LL	Overpressure below lower alarm limit value	Vn+P
89 A	13-2	Pu>Alarm-UL	Overpressure above upper alarm limit value	Vn+P
90 A	13-3	Pu-jump	Overpressure gradient above upper maximum	Vn+P
94 A	19-0	N2 failure	Nitrogen failure	Vn+GC
95 A	19-1	N2<LL alarm	Nitrogen below lower alarm limit value	Vn+GC
96 A	19-2	N2>UL alarm	Nitrogen above upper alarm limit value	Vn+GC
97 A	19-3	N2-jump	Nitrogen gradient above upper maximum	Vn+GC
105 A	32-2	CRC12 error	Calibration requirement of GC data violated	GC
110 A	32-7	v.d.Waals Alm	Van der Waals iteration error	Vn+GC
157 A	39-8	Qp failure	Current-proportional flow failure	Vb+Vn
164 A(R)	42-1	RTC defect	Time chip is defective	Vb+Vn
165 A	43-2	Totalizer defect	Totalizer defect	Vb+Vn
195 A	48-0	CAN timeout	CAN-bus timeout	Vb+Vn+P+T
200 A	48-5	S-coefficient error	Primary value for status coefficient calculation missing	Vn
203 A	50-0	T<>GERG lim.	Temperature beyond GERG limits	Vn+T
204 A	50-1	P<>GERG-lim.	Pressure beyond GERG limits	Vn+P
205 A	50-2	Dv<>GERG lim.	Density ratio beyond GERG limits	Vn+GC
206 A	50-3	CO2<>GERG lim.	Carbon dioxide beyond GERG limits	Vn+GC
207 A	50-4	N2<>GERG lim.	Nitrogen beyond GERG limits	Vn+GC
208 A	50-5	Ho<>GERG lim.	Calorific value beyond GERG limits	Vn+GC
209 A	50-6	H2<>GERG lim.	Hydrogen beyond GERG limits	Vn+GC
210 A	50-8	GERG lterMax	Maximum permissible GERG iterations exceeded	Vn
211 A	51-0	T<>AGA limit	Temperature beyond AGA limits	Vn+T
212 A	51-1	P<>AGA limit	Pressure beyond AGA limits	Vn+P
213 A	51-2	Dv<>AGA limit	Density ratio beyond AGA limits	Vn+GC
214 A	51-3	CO2<>AGA limit	Carbon dioxide beyond AGA limits	Vn+GC
215 A	51-4	N2<>AGA limit	Nitrogen beyond AGA limits	Vn+GC
216 A	51-5	Ho<>AGA limit	Calorific value beyond AGA limits	Vn+GC
217 A	51-6	H2<>AGA limit	Hydrogen beyond AGA limits	Vn+GC
218 A	51-7	AGA algorithm.	AGANX algorithmic error panic	Vn
219 A	51-8	AGA Pi,Tau	AGA intermediate transm. Pi,Tau beyond limits	Vn+P+T
220 A	51-9	Support point prob-	Error in the support point calculation	Vn

		lem		
227 A	52-6	impermissible	Impermissible operating mode	Vb+Vn
248 A(R)	56-0	Channel 1 error	Channel 1 pulse count implausible	Vb+Vn
249 A(R)	56-1	Channel 2 error	Channel 2 pulse count implausible	Vb+Vn
250 A	56-2	TB/TN combi.	TB/TN combination impermissible	Vn
256 A(R)	56-8	Channel 3 error	Channel 3 pulse count implausible	Vb+Vn
257 A(R)	56-9	Channel 4 error	Channel 4 pulse count implausible	Vb+Vn
323 A	65-6	Rn fail. 2EW	Second input value standard density failure	Vn+GC
365 A(R)	71-4	NMA ADC	Namur module A analog converter	Vn+P+T
366 A(R)	71-5	NMA overload	Namur module A overload	Vn+P+T
367 A(R)	71-6	NMA Lb PT100	Namur module A PT100 wire break	Vn+T
368 A(R)	71-7	NMA Lb meas. ch.	Namur module A measuring channel wire break	Vb+Vn
369 A(R)	71-8	NMA Lb comp. ch.	Namur module A comparison channel wire break	Vb+Vn
371 A(R)	72-0	NMB ADC	Namur module B analog converter	Vn+P+T
372 A(R)	72-1	NMB overload	Namur module B overload	Vn+P+T
373 A(R)	72-2	NMB Lb PT100	Namur module B PT100 wire break	Vn+T
374 A(R)	72-3	NMB Lb meas. ch.	Namur module B measuring channel wire break	Vb+Vn
375 A(R)	72-4	NMB Lb comp. ch.	Namur module B comparison channel wire break	Vb+Vn
401 A	77-0	DP1 (<3mA)	Delta-P cell 1 current less than 3 mA	Vb+Vn+dP
402 A	77-1	DP2 (<3mA)	Delta-P cell 2 current less than 3 mA	Vb+Vn+dP
403 A	77-2	DP3 (<3mA)	Delta-P cell 3 current less than 3 mA	Vb+Vn+dP
404 A	77-3	Beta impermissible	Impermissible orifice plate/pipe ratio	Vn+dP
405 A	77-4	DP1 failure	Delta-P cell 1 failure	Vb+Vn+dP
406 A	77-5	DP2 failure	Delta-P cell 2 failure	Vb+Vn+dP
407 A	77-6	DP3 failure	Delta-P cell 3 failure	Vb+Vn+dP
408 A	77-7	DP>max.	Delta-P above maximum	Vn+dP
413 A	78-2	GQM list	GQM list is incorrect	GC
414 A	78-3	MGC unknown	Main GC unknown identification	GC
415 A	78-4	CGC unknown	Comparison GC unknown identification	GC
416 A	78-5	MGC CRC12	Main GC CRC12 implausible	GC
417 A	78-6	CGC CRC12	Comparison GC CRC12 implausible	GC
430 A	80-0	dkvk>max.	Max. deviation in operating point exceeded	Vn
431 A	80-1	IGM substitute value	Invalid substitute value used for IGM	Vb+Vn
432 A	80-2	Pathfail>perm.	Number of failed paths too high	Vb+Vn
434 A	80-4	ETA failure	Viscosity failure	Vn+dP
435 A	80-5	ETA<Alarm-LL	Viscosity below lower alarm limit value	Vn+dP
436 A	80-6	ETA>Alarm-UL	Viscosity above upper alarm limit value	Vn+dP
440 A	81-0	ETA-jump	Viscosity gradient above upper maximum	Vn+dP
466 A	83-6	HFX pulse failure	Measuring channel (HFX) pulse count failure	Vb+Vn
467 A	83-7	HFY pulse failure	Comparison channel (HFY) pulse count failure	Vb+Vn
468 A	84-0	Kappa failure	Isentropic exponent failure	Vn+dP
469 A	84-1	Kappa<Alarm-LL	Isentropic exponent below lower alarm limit value	Vn+dP
470 A	84-2	Kappa>Alarm-UL	Isentropic exponent above upper alarm limit value	Vn+dP
474 A	84-6	Kappa jump	Isentropic exponent gradient above upper maximum	Vn+dP

501 A	89-0	JTC failure	Joule Thomson coef. Viscosity	Vn+T+dP
502 A	89-1	JTC<Alarm-LL	Joule Thomson coef. below lower alarm limit value	Vn+T+dP
503 A	89-2	JTC>Alarm-UL	Joule Thomson coef. above upper alarm limit value	Vn+T+dP
507 A	89-6	JTC-jump	Joule Thomson coef. gradient above maximum	Vn+T+dP
527 A	91-8	GC components	GC components for full analysis bad	Vn+GC
543 A	93-5	DZU alarm	DZU sensor signals alarm	Vb+Vn
544 A	93-6	DZU timeout	DZU sensor communication error	Vb+Vn
556 A(R)	95-0	Math problem	Mathematical error	Vb+Vn
557 A	95-1	Code corrupt	Corrupt code detected	Vb+Vn
558 A	95-2	Alarm vol. trans.	activated. Contact volume transmitter indicates alarm	Vb+Vn
566 A	96-0	DR failure	Density ratio failure	GC
567 A	96-1	DR<Alarm-LL	Density ratio below lower alarm limit value	GC
568 A	96-2	DR>Alarm-UL	Density ratio above upper alarm limit value	GC
569 A	96-3	DR jump	Density ratio gradient above upper maximum	GC
573 A	96-7	Ho GC timeout	Calorific value sensor communication error	GC
574 A	96-8	Rn GC timeout	Nominal density sensor communication error	GC
575 A	96-9	DR GC timeout	Density ratio sensor communication error	GC
576 A	97-0	CO2 GC timeout	CO2 sensor communication error	GC
577 A	97-1	N2 GC timeout	N2 sensor communication error	GC
578 A	97-2	H2 GC timeout	H2 sensor communication error	GC
579 A	97-3	Ho GC alarm	GC reports calorific value failure	Vn+GC
580 A	97-4	Rn GC alarm	GC reports nominal density failure	Vn+GC
581 A	97-5	DR GC alarm	GC reports density ratio failure	Vn+GC
582 A	97-6	CO2 GC alarm	GC reports carbon dioxide failure	Vn+GC
583 A	97-7	N2 GC alarm	GC reports nitrogen failure	Vn+GC
584 A	97-8	H2 GC alarm	GC reports hydrogen failure	Vn+GC
585 A	97-9	Beattie alarm	Beattie&Bridgeman iteration error	Vn
586 A	98-0	CH4 failure	Methane failure	GC
587 A	98-1	CH4<LL alarm	Methane below lower alarm limit value	GC
588 A	98-2	CH4>UL alarm	Methane above upper alarm limit value	GC
589 A	98-3	CH4-jump	Methane gradient above upper maximum	GC
593 A	98-7	Comp.standardization	Error in standardization of gas components	Vn+GC
596 A	99-2	CH4 GC timeout	Methane sensor not reporting	GC
597 A	99-3	CH4 GC alarm	GC reports methane failure	GC
599 A	99-5	VOS corr. error	Error in VOS correction calculation	Vn
601 A	99-7	AGA8 alarm	AGA 8 algorithmic error	Vn
602 A	99-8	AGA8 92DC Alm	AGA 8 92DC algorithmic error	Vn

## .J.2.2 Modbus EGO

This is a special interface for *Erdgas Ostschweiz*. EGO-specific Modbus registers are:

Register	Data type	Column	Group	Value	Value	
Bytes	Access	Line	Description	(Display)	(Modbus)	413
2000	4 unsigned integer 32-bit	R IP 1	EGO-Modbus Vn totalizer	4044123 m3	00 3D B5 5B	
2002	4 unsigned integer 32-bit	R IP 2	EGO-Modbus Vb totalizer	114962 m3	00 01 C1 12	
2004	4 unsigned integer 32-bit	R IP 3	EGO-Modbus Energy totalizer	57809 MWh	00 00 E1 D1	
2006	4 unsigned integer 32-bit	R IP 4	EGO-Modbus Vn dist. totalizer	675679 m3	00 0A 4F 5F	
2008	4 unsigned integer 32-bit	R IP 5	EGO-Modbus Vb dist. totalizer	18095 m3	00 00 46 AF	
2010	4 unsigned integer 32-bit	R IP 6	EGO-Modbus Energy dist. totalizer	7132 MWh	00 00 1B DC	
2012	4 float IEEE 754	R IP 7	EGO-Modbus Vn flow rate	6779.9 m3/h	45 D3 DF 5A	
2014	4 float IEEE 754	R IP 8	EGO-Modbus Vb flow rate	151.0 m3/h	43 17 06 FA	
2016	4 float IEEE 754	R IP 9	EGO-Modbus Energy flow rate	81359.0 kW	47 9E E7 84	
2018	4 float IEEE 754	R/W IP 10	EGO-Modbus Standard density	0.80 kg/m3	3F 4C CC CD	
2020	4 float IEEE 754	R/W IP 11	EGO-Modbus Calorific value	12.0 kWh/m3	41 40 00 00	
2022	4 float IEEE 754	R/W IP 12	EGO-Modbus Hydrogen	0.0 mol-%	00 00 00 00	
2024	4 float IEEE 754	R/W IP 13	EGO-Modbus Carbon dioxide	1.02 mol-%	3F 82 9C BC	
2026	4 float IEEE 754	R IP 14	EGO-Modbus Operating density	35.9 kg/m3	42 0F A7 8C	
2028	4 float IEEE 754	R IP 15	EGO-Modbus Absolute pressure	42.000 bar	42 28 00 00	
2030	4 float IEEE 754	R IP 16	EGO-Modbus Temperature	10.00 °C	41 20 00 00	
2032	2 unsigned integer 16-bit	R IP 17	EGO-Modbus alarm	0	00 00	

### Important points

- The ERZ2000-NG is a Modbus slave.
  - Supported function codes:
 

03	Read holding register	Read data
16	Preset multiple registers	Write data
  - The register addresses are referenced to 0 (zero).  
If, for example, register 2000 is queried on the interface, coordinate **IB17 Register offset = "0"** must be parameterized.
  - Totalizers and disturbance totalizers correspond to billing mode 1.
  - Standard density, calorific value, hydrogen and carbon monoxide can be described via Modbus.
- In order to ensure that the values are used for conversion, the operating mode of the corresponding measurement input must be parameterized to EGO Modbus.
- There is no special EGO interface operating mode.
  - EGO mode only works advantageously with GERG 88.
  - EGO mode does not work with billing mode 2, 3, 4.

- EGO mode does not work with 14-digit totalizers.
- EGO mode defines fixed values in advance (m<sup>3</sup>, kWh, m<sup>3</sup>/h, kW, kg/m<sup>3</sup>, mol.%, bar, degrees Cel.).
- Meaning of the alarm status in register 2032:

414

0	No alarm
1	Hardware fault(s) of the corrector
2	Hardware fault(s) of pulse detection
3	Limit fault(s) of volume measurements
4	Hardware /limit fault(s) of other transmitters
5	GERG limit violation
6	Other alarms
7...9	Spare

- For standard density, calorific value, hydrogen and carbon dioxide, an initialization value (float 999999) is agreed upon, which is always sent by the Modbus master when there is no measurement available.



### .J.2.3 Transgas Modbus

Coordinate **IB27 Modbus project** enables project-specific assignment of the Modbus register upwards from 9000. For data exchange with a bus coupler for Portugal, the Transgas setting must be chosen. This provides the following register assignment:

415

Register	Bytes	Data type	Access	Column	Line	Group	Description	Value (Display)	Value (Modbus)
9000	4	float IEEE 754	R	AB	1	Absolute pressure	Measurement variable	25.000 bar	41 C8 00 00
9002	4	float IEEE 754	R	AC	1	Gas temperature	Measurement variable	16.421568 °C	41 83 5F 5F
9004	4	float IEEE 754	R	HF	1	Operating flow corr.	Measurement variable	310.267 m3/h	43 9B 22 29
9006	4	float IEEE 754	R	HD	1	Standard volume flow	Measurement variable	7718.06 m3/h	45 F1 30 79
9008	4	float IEEE 754	R	AD	1	Calorific value	Measurement variable	12.000 kWh/m3	41 40 00 00
9010	4	float IEEE 754	R	AE	1	Standard density	Measurement variable	0.8880 kg/m3	3F 63 53 F8
9012	4	unsigned integer 32-bit	R	LB	4	Totalizer AM1	Energy	126843 MWh	00 01 EF 7B
9014	4	unsigned integer 32-bit	R	LB	7	Totalizer AM1	Op.vol. corr.	447724 m3	00 06 D4 EC
9016	4	unsigned integer 32-bit	R	LB	1	Totalizer AM1	Standard volume	9803707 m3	00 95 97 BB
9018	4	unsigned integer 32-bit	R	LC	4	Disturbance totalizer AM1	Energy	21422 MWh	00 00 53 AE
9020	4	unsigned integer 32-bit	R	LC	7	Disturbance totalizer AM1	Op.vol. corr.	92001 m3	00 01 67 61
9022	4	unsigned integer 32-bit	R	LC	1	Disturbance totalizer AM1	Standard volume	1869267 m3	00 1C 85 D3
9024	4	signed integer 32-bit	R	FG	10	Hardware test	Alarm LED	On	00 00 00 01
								Options:	Off = 0
									On = 1
									blinking = 2
9026	4	signed integer 32-bit	R	FG	9	Hardware test	Warning LED	Off	00 00 00 00
								Options:	Off = 0
									On = 1
									blinking = 2
9028	2	unsigned integer 16-bit	R	YES	28	Error messages	Bits for regulation	0000 hex	00 00
9029	2	unsigned integer 16-bit	R	KB	10	Time output	Modbus year	2010	07 DA
9030	2	unsigned integer 16-bit	R	KB	11	Time output	Modbus month	6	00 06

416

9031	2	unsigned integer 16-bit	R	KB	12	Time output	Modbus day	24	00 18
9032	2	unsigned integer 16-bit	R	KB	13	Time output	Modbus hour	13	00 0D
9033	2	unsigned integer 16-bit	R	KB	14	Time output	Modbus minute	30	00 1E
9034	2	unsigned integer 16-bit	R	KB	15	Time output	Modbus second	49	00 31
9500	4	float IEEE 754	R/W	IJ	3	Imp. GC Modbus main	Calorific value	12.000 kWh/m3	41 40 00 00
9502	4	float IEEE 754	R/W	IJ	5	Imp. GC Modbus main	Standard density	0.8880 kg/m3	3F 63 53 F8
9504	4	float IEEE 754	R/W	IJ	6	Imp. GC Modbus main	CO2	1.00000 mol-%	3F 80 00 00
9506	2	unsigned integer 16-bit	R/W	KC	60	Time entry	Modb.Sync year	2010	07 DA
9507	2	unsigned integer 16-bit	R/W	KC	61	Time entry	Modb.Sync month	6	00 06
9508	2	unsigned integer 16-bit	R/W	KC	62	Time entry	Modb.Sync day	14	00 0E
9509	2	unsigned integer 16-bit	R/W	KC	63	Time entry	Modb.Sync hour	11	00 0B
9510	2	unsigned integer 16-bit	R/W	KC	64	Time entry	Modb.Sync minute	55	00 37
9511	2	unsigned integer 16-bit	R/W	KC	65	Time entry	Modb.Sync second	12	00 0C
9512	2	unsigned integer 16-bit	R/W	KC	66	Time entry	Modb.Sync.trig ger	0	00 00

### Example of the special configuration

#### IB Serial interfaces

B 7	Baud rate COM3	38400
B 8	B/P/S COM3	8N1
B 9	COM3 Operating mode	Modbus-RTU
B 17	Register offset	0
B 18	Modbus address	201
B 22	Modbus addr. COM1	0
B 23	Modbus addr. COM2	0
B 24	Modbus addr. COM3	0
B 27	Modbus project	Transgas

**AD Superior calorific value**

E § 3	Oper. mode	Modbus
-------	------------	--------

**AE Standard density**

E § 3	Oper. mode	Modbus
-------	------------	--------

**BA Component mode**

E § 1	CO2 oper. mode	Modbus
-------	----------------	--------

**KC External time signal**

T	1	Sync mode input	Modbus	
T	2	Time sync. tolerance	0	s
E § 3		Time sync. rule	always	

**Notices**

- Time and data of the computer are synchronized by the bus coupler in 30-second intervals only.
- Factors D13, D14 and D15 must be observed for the writing of Ho, Rhon and CO2.

**.J.2.4 Eon gas transport Modbus**

With the setting IB27 Modbus project = EGT, the Modbus register is assigned from 9000 upwards, as required by Eon Gas Transport for the Werne project. The description of this standard register assignment is beyond the scope of this device manual. However, the details are included in the device-internal documentation and can be viewed by browser on the network interface under documentation / III.MODBUS /2.Register Werne-Projekt.

## K) Cross-references to coordinates

All menus and coordinates are listed below. A corresponding cross-reference to the menus and coordinates listed in the preceding text is provided.

418

### K.1 A Measurements

#### AA Overview (Measurements function key)

See *chapter 4 Transmitters*

#### AB Absolute pressure

See *chapter 4.2 Pressure transducer*

#### AC Gas temperature

See *chapter 4.3 Temperature transducer*

#### AD Superior calorific value

See *chapter 6.2.1 AD Superior calorific value*

#### AE Standard density

See *chapter 6.2.2 AE Standard density*

#### AF Relative density

See *chapter 6.2.4 AF Relative density*

#### AG Density

See *chapter 6.2.5 AG Density*

#### AH Temperature of the density transmitter

See *chapter 6.2.6 AH Temperature of the density transmitter*

#### AI Temperature for VOS correction

See *chapter 6.2.7 AI Temperature for VOS correction*

#### AJ Velocity of sound at measurement conditions

See *chapter 6.2.8 AJ Velocity of sound at measurement conditions*

#### AK Velocity of sound at base conditions

See *chapter 6.2.9 AK Velocity of sound at base conditions*

#### AL Inside temperature of device

See *chapter 4.3.1 AL internal temperature of the device*

#### AM Viscosity

See *chapter 6.2.10 AM Viscosity*

**AN Isentropic exponent**

See *chapter 6.2.11 AN Isentropic exponent*

**AO Joule-Thomson coefficient**

See *chapter 6.2.12 AO Joule-Thomson coefficient*

419

**AP differential pressure**

See *chapter 5.5.2 AP diff.pressure*

**AQ Flow proportional signal**

See *chapter 5.1.1 AQ 4-20 mA flow*

## K.2 B Components

### BA Components mode

See *chapter 6.1.1 BA Components mode*

### BB Carbon dioxide

See *chapter 6.1.2 BB Carbon dioxide*

### BC Hydrogen

See *chapter 6.1.2 BB Carbon dioxide*

### BD Nitrogen

See *chapter 6.1.2 BB Carbon dioxide*

### BE Methane

See *chapter 6.1.3 BE Methane*

### BF Ethane

See *chapter 6.1.3 BE Methane*

### BG Propane

See *chapter 6.1.3 BE Methane*

### BH N-butane

See *chapter 6.1.3 BE Methane*

### BI I-butane

See *chapter 6.1.3 BE Methane*

### BJ N-pentane

See *chapter 6.1.3 BE Methane*

### BK I-pentane

See *chapter 6.1.3 BE Methane*

### BL Neo-pentane

See *chapter 6.1.3 BE Methane*

### BM Hexane

See *chapter 6.1.3 BE Methane*

### BN Heptane

See *chapter 6.1.3 BE Methane*

### BO Octane

See *chapter 6.1.3 BE Methane*

**BP Nonane**

See *chapter 6.1.3 BE Methane*

**BQ Decane**

See *chapter 6.1.3 BE Methane*

**BR Hydrogen sulphide**

See *chapter 6.1.3 BE Methane*

421

**BS Water**

See *chapter 6.1.3 BE Methane*

**BT Helium**

See *chapter 6.1.3 BE Methane*

**BU Oxygen**

See *chapter 6.1.3 BE Methane*

**BV Carbon monoxide**

See *chapter 6.1.3 BE Methane*

**BW Ethene**

See *chapter 6.1.3 BE Methane*

**BX Propene**

See *chapter 6.1.3 BE Methane*

**BY Argon**

See *chapter 6.1.3 BE Methane*

## K.3 C Analysis

### CA Overview (Analysis function key)

See chapter 6.3.1 CA Overview (Analysis function key)

### CB Conversion factor

See chapter 6.3.2 CB Conversion factor

### CC Calculation of the compressibility coefficient

See chapter 6.3.3 CC Calculation of K coefficient

### CD Gerg equation of state

See chapter 6.3.4 GERG 88 S

### CE AGA NX 19 equation of state

See chapter 6.3.5 CE AGA NX 19 equation

### CF AGA NX 19 equation of state with correction for H group gas

See chapter 6.3.3 CC Calculation of K coefficient

### CG AGA 8 equation of state of 1985

See chapter 6.3.3 CC Calculation of K coefficient

### CH AGA 8 92DC equation of state

See chapter 6.3.6 CH AGA 8 92DC equation

### CI Beattie & Bridgeman equation of state

See chapter 6.3.3 CC Calculation of K coefficient

### CJ Van der Waals equation of state

See chapter 6.3.3 CC Calculation of K coefficient

### CK Industrial gases parameter

See chapter 6.3.7 CK Industrial gases parameter

### CL AGA8 gross method

See chapter 6.3.3 CC Calculation of K coefficient.

### CM Conversion factor comparison

See chapter 6.3.3 CC Calculation of K coefficient

### CN C6+ -Distribution

See chapter 6.3.8 CN C6+ -Distribution

### CO Peng-Robinson

See chapter 6.3.3 CC Calculation of K coefficient



## K.4 D Calculation values

### DA Calculations in accordance to ISO 6976

See chapter 6.4.1 DA Calculations according to ISO 6976

### DB calculation according to AGA 10 / Helmholtz ISO20765-1:2005

See chapter 6.4.2 DB Calculation according to AGA10/Helmholtz ISO20765-1:2005

---

 423
 

---

### DC Transport phenomena

See chapter 6.4.3 DC Transport

### DD Critical values

See chapter 6.4.4 DD Critical values

### DE Stoichiometry

See chapter 6.4.5 DE Stoichiometry

### DF Impact on environment in case of complete combustion

See chapter 6.4.6 DF Environment

### DG Correction of velocity of sound

See chapter 6.4.9 DG Correction of velocity of sound

### DH Assessed analysis

See chapter 6.4.10 DH Assessed analysis

### DI Adjustable extra base condition

See chapter 6.4.11 DI Adjustable extra base condition

### DJ Exhaust summary

See chapter 6.4.7 DJ Exhaust summary

### DK Composition of exhaust fumes

See chapter 6.4.8 DK Composition of exhaust fumes

### DL Calculations according GPA 2172-96

See chapter 6.4.12 DL Calculations according to GPA 2172-96

**K.5 E Mode****EB Base values**

See *chapter 6.5.1 EB Base values*

**EC Billing mode**

See *chapter 5.2.1 EC Billing mode*

**ED Parameter access**

See *chapter 2.3 Access protection for data and settings*

**EE Display**

See *chapter 2.4 Basic settings*

**EF Processing table values**

See *chapter 6.5.2 EF Processing table values*

**EG ID display**

See *chapter 2.5.5.3 Type plate*

**EH Module assembly**

See *chapter 2.7.1 Equipment variants*

**EI Configuration**

See *chapter 2.7.2 Configuration of connections*

**EJ Identification of software**

See *chapter 1.5.4 Signature, software and hardware data*

**EK Identification of hardware**

See *chapter 1.5.4 Signature, software and hardware data*

**EL Description site**

See *chapter 2.4 Basic settings*

**EM Erasing procedures**

See *chapter 2.5.6 Archive*

**ER Signature**

See *chapter 1.5.4 Signature, software and hardware data*

**ES Parameter change**

See *chapter 2.4 Basic settings*

**K.6 F Test**

**FA Control panel**

See *chapter .A.5.1 FA Control panel*

**FB On-the-fly calibration**

See *chapter .A.5.2 FB On-the-fly calibration*

425

**FC Freeze**

See *chapter .A.5.3 FC Freeze*

**FD Computing cycle**

See *chapter .A.5.4 FD Corrector cycle*

**FE Calibration unit standard density / gross calorific value**

See *chapter 6.5.3 FE Calibration unit standard density / gross calorific value*

**FF Function test under running conditions**

See *chapter .A.5.5 FF Function test under running conditions*

**FG Hardware test**

See *chapter .A.5.6 FG Hardware test*

**FJ File system**

See *chapter .A.5.7 FJ File system*

**FK Boole functions**

See *chapter .A.5.8 FK Boole function*

## **K.7 G Totalizer/volume transmitter**

### **GA Tube dimensions**

See *chapter 5.5.1 GA Tube dimensions*

### **GB Flow rate parameters**

See *chapter 5.1.2 GB Flow rate parameters*

### **GC kv factor**

See *chapter 5.1.3 GC kv factor*

### **GD Determination of characteristic curve**

See *chapter 5.1.4 GD Characteristic curve determination*

### **GE Error curve linearisation, forward flow**

See *chapter 5.1.5 GE Error curve linearisation, forward flow*

### **GF Error curve linearisation, reverse flow**

See *chapter 5.1.5 GE Error curve linearisation, forward flow*

### **GG Flow**

See *chapter 5.1.6 GG Flow*

### **GH Start-up and shut-down monitoring**

See *chapter 5.1.7 GH Start-up and shut-down monitoring*

### **GJ Body compensation**

See *chapter 5.3.1 GJ Body compensation*

### **GU Namur sensor adjustment**

See *chapter 3.4 NAMUR sensor adjustment (optional)*

### **GV Orifice**

See *chapter 5.5 Orifice plate diameter*

### **GW Extremal values for expanded type plate**

See *chapter 5.5 Orifice plate diameter*

### **GX Roughness of tube**

See *chapter 5.5 Orifice plate diameter*

### **GY Abrasion of orifice edge**

See *chapter 5.5 Orifice plate diameter*

### **GZ Orifice function key**

See *chapter 5.5 Orifice plate diameter*

**K.8 H Flow rate**

**HA Overview**

*See chapter 5.1.8 HB Energy flow*

**HB Energy flow rate**

*See chapter 5.1.8 HB Energy flow*

427

**HC Mass flow rate**

*See chapter 5.1.8 HB Energy flow*

**HD Volumetric flow rate at base conditions**

*See chapter 5.1.8 HB Energy flow*

**HE Volumetric flow rate at measurement conditions**

*See chapter 5.1.8 HB Energy flow*

**HF Corrected volumetric flow rate at measurement conditions**

*See chapter 5.1.8 HB Energy flow*

**HG Mass flow rate broken down into components**

*See chapter 5.1.8 HB Energy flow*

## **K.9 I Communication**

### **IA TCP/IP network**

See *chapter 3.5.1 IA TCP/IP network*

### **IB Serial COMs**

See *chapter 2.7.5 Pin assignment and recommended use of the interfaces*  
and *2.7.6 External modem connection*

### **IC General DSfG**

See *chapter 3.5.2 IC DSfG instance computer*

### **ID DSfG entity recording**

See *chapter 3.5.3 ID DSfG entity recording*

### **IE Remote data transmission access**

See *chapter 3.5.4 IE IE Remote data transmission access*

### **IF DSfG master**

See *chapter 3.5.5 IF DSfG*

### **IG Imported gas quality via DSfG**

See *chapter 6.6.1 IG Imported gas quality via DSfG*

### **IH Imported gas quality via RMG bus**

See *chapter 6.6.6 IH Imported gas quality via RMG bus*

### **II Modbus superblock**

See *chapter 3.3.1 Concept*

### **IJ Imported main gas quality via modbus**

See *chapter 6.6.2 IJ Imp. GC Modbus main*

### **IK Imported backup gas quality via modbus**

See *chapter 6.6.3 IK Imp. GC Modbus ref*

### **IL GC1 Modbus master**

See *chapter 6.6.4 IL Modbus Master*

### **IM GC2 Modbus master**

See *chapter 6.6.5 IM Modbus Master*

### **IO DSfG tandem counter comparison**

See *chapter .J.1.2 Cross-comparison via DSfG*

### **IP Modbus EGO Erdgas Ostschweiz**

See *chapter 6.6.7 IP Modbus EGO Erdgas Ostschweiz*

## K.10 J Fault messages

### JA Fault messages

See *chapter 8.1.1 JA Fault messages*

### JB Message registers

See *chapter 8.1.2 JB Message register*

---

 429
 

---

### CJ GIA-bit table

See *chapter 8.1.3 CJ GIA-Bit table*

### JD Debugging

See *chapter 8.1.4 JD Debugging*

---



---

## K.11 K Times

### KA Times

See *chapter 2.6.1 KA Times and time settings*

### KB Time contact signal to external devices

See *chapter 2.6.2 KB Time contact signal to external devices*

### KC External time signal

See *chapter 2.6.3 KC external time signal*

### KD Plausibility controls of time

See *chapter 2.6.4 KD Plausibility*

## **K.12 L Totalizers**

### **LA Overview**

See *chapter 2.5.1.4 Counters* and  
*2.5.1.5 Customer-specific counters (customer counters)*

### **LB Totalizer BM 1**

See *chapter 2.5.1.4 Counters* and  
*2.5.1.5 Customer-specific counters (customer counters)*

### **LC Disturbance totalizer BM 1**

See *chapter 2.5.1.4 Counters* and  
*2.5.1.5 Customer-specific counters (customer counters)*

### **LD Totalizer BM 2**

See *chapter 2.5.1.4 Counters* and  
*2.5.1.5 Customer-specific counters (customer counters)*

### **LE Disturbance totalizer BM 2**

See *chapter 2.5.1.4 Counters* and  
*2.5.1.5 Customer-specific counters (customer counters)*

### **LF Totalizer BM 3**

See *chapter 2.5.1.4 Counters* and  
*2.5.1.5 Customer-specific counters (customer counters)*

### **LG Disturbance totalizer BM 3**

See *chapter 2.5.1.4 Counters* and  
*2.5.1.5 Customer-specific counters (customer counters)*

### **LH Totalizer BM 4**

See *chapter 2.5.1.4 Counters* and  
*2.5.1.5 Customer-specific counters (customer counters)*

### **LI Disturbance totalizer BM 4**

See *chapter 2.5.1.4 Counters* and  
*2.5.1.5 Customer-specific counters (customer counters)*

### **LJ Totalizer, undefined billing mode**

See *chapter 2.5.1.4 Counters* and  
*2.5.1.5 Customer-specific counters (customer counters)*

### **LK Counter parameter**

See *chapter 2.5.1.4 Counters* and  
*2.5.1.5 Customer-specific counters (customer counters)*



**LL Monitoring of synchronous run**

See *chapter 5.1.2 GB Flow rate parameters*

**LN Original totalizer, encoder totalizer terminal X4 or X9**

See *chapter 5.2.1 EC Billing mode*

**LO Digital totalizer transmission, ultrasonic flow meter**

See *chapter 5.3.18 LO Digital totalizer transmission*

---

 431
 

---

**LP Setting totalizers**

See *chapter 2.5.1.4 Counters and  
2.5.1.5 Customer-specific counters (customer counters)*

**LQ Monthly quantities**

See *chapter 7.1.1 LS Hourly quantities*

**LS Hourly quantities**

See *chapter 7.1.1 LS Hourly quantities*

**LT Daily quantities**

See *chapter 7.1.1 LS Hourly quantities*

**LU Quantity weighted average values**

See *chapter 6.2.3 LU Quantity weighted average values*

**LV Customer specific totalizer set A**

See *chapter 2.5.1.4 Counters and  
2.5.1.5 Customer-specific counters (customer counters)*

**LW Customer specific totalizer set B**

See *chapter 2.5.1.4 Counters and  
2.5.1.5 Customer-specific counters (customer counters)*

**LX Customer specific totalizer setting**

See *chapter 2.5.1.4 Counters and  
2.5.1.5 Customer-specific counters (customer counters)*

**LZ Counter increment values of current flow computer cycle**

Displaying menu only.

## K.13 M Outputs

### MA Overview

See *chapter 2.7.10 MA Input / output function key*

### MB Current output 1

See *chapter 2.7.17 MB Current output 1*

### MC Current output 2

See *chapter 2.7.17 MB Current output 1*

### MD Current output 3

See *chapter 2.7.17 MB Current output 1*

### ME Current output 4

See *chapter 2.7.17 MB Current output 1*

### MF Pulse output 1

See *chapter 2.7.18 MF Pulse output 1*

### MG Pulse output 2

See *chapter 2.7.18 MF Pulse output 1*

### MH Pulse output 3

See *chapter 2.7.18 MF Pulse output 1*

### MI Pulse output 4

See *chapter 2.7.18 MF Pulse output 1*

### MJ Contact output 1

See *chapter 2.7.19 MJ Contact output 1*

### MK Contact output 2

See *chapter 2.7.19 MJ Contact output 1*

### ML Contact output 3

See *chapter 2.7.19 MJ Contact output 1*

### MM Contact output 4

See *chapter 2.7.19 MJ Contact output 1*

### MN Contact output 5

See *chapter 2.7.19 MJ Contact output 1*

### MO Contact output 6

See *chapter 2.7.19 MJ Contact output 1*

**MP Contact output 7**

*See chapter 2.7.19 MJ Contact output 1*

**MQ Contact output 8**

*See chapter 2.7.19 MJ Contact output 1*

---

**433**

---

**MR Frequency output 1**

*See chapter 2.7.20 MR Frequency output 1*

---

---

---

**K.14 N Inputs****NA Current input 1**

*See chapter 2.7.11 NA Current input 1*

**NB Current input 2**

*See chapter 2.7.11 NA Current input 1*

**NC Current input 3**

*See chapter 2.7.11 NA Current input 1*

**ND Current input 4**

*See chapter 2.7.11 NA Current input 1*

**NE Current input 5**

*See chapter 2.7.11 NA Current input 1*

**NF Current input 6**

*See chapter 2.7.11 NA Current input 1*

**NG Current input 7**

*See chapter 2.7.11 NA Current input 1*

**NH Current input 8**

*See chapter 2.7.11 NA Current input 1*

**NI Resistance Input 1**

*See chapter 2.7.12 NI Res. input 1*

**NJ Resistance Input 2**

*See chapter 2.7.12 NI Res. input 1*

**NL Frequency input 1**

*See chapter 2.7.13 NL Frequency input 1*

**NM Frequency input 2**

*See chapter 2.7.13 NL Frequency input 1*

**NN Frequency input 3**

*See chapter 2.7.13 NL Frequency input 1*

**NO Frequency input 4**

*See chapter 2.7.13 NL Frequency input 1*

**NP Frequency input 5**

*See chapter 2.7.13 NL Frequency input 1*

**NQ Frequency input 6**

See chapter 2.7.13 NL Frequency input 1

**NR Frequency input 7**

See chapter 2.7.13 NL Frequency input 1

**NS Frequency input 8**

See chapter 2.7.13 NL Frequency input 1

**NT Contact inputs**

See chapter 2.7.14 NT Contact inputs

**NU Current input 9 Exi**

See chapter 2.7.15 NU Current input 9 Exi

**NV Current input 10 Exi**

See chapter 2.7.15 NU Current input 9 Exi

**NW Current input 11 Exi**

See chapter 2.7.15 NU Current input 9 Exi

**NX Current input 12 Exi**

See chapter 2.7.15 NU Current input 9 Exi

**NY Resistance measurement 3**

See chapter 2.7.16 NY Resistance measurement 3

**NZ Resistance measurement 4**

See chapter 2.7.16 NY Resistance measurement 3

**K.15 O Miscellaneous****OA DSfG archive**

See *chapter .C.1.1 OA DSfG archive*

**OB Gauge pressure**

See *chapter 4.2 Pressure transducer*

**OC Function**

See *chapter .C.1.2 OC Function*

**OD Input values**

See *chapter .C.1.3 OD Input values*

**OE Miscellaneous**

See *chapter .C.1.4 OE Miscellaneous*

**OF Extra analog value 1**

See *chapter 4.4 Special measurements*

**OG Extra analog value 2**

See *chapter 4.4 Special measurements*

**OH Extra analog value 3**

See *chapter 4.4 Special measurements*

**OI Extra analog value 4**

See *chapter 4.4 Special measurements*

**OJ Extra analog value 5**

See *chapter 4.4 Special measurements*

**OK Extra analog value 6**

See *chapter 4.4 Special measurements*

**OL Extra analog value 7**

See *chapter 4.4 Special measurements*

**OM Extra analog value 8**

See *chapter 4.4 Special measurements*

**ON Extra messages**

See *chapter 8.1.5 ON Extra messages*

**OO Extra counter 1**

See *chapter 5.1.9 OO Extra*

**OP Extra counter 2**

See *chapter 5.1.9 OO Extra*

**OQ Special counter 3**

*See chapter 5.1.9 OO Extra*

**OR Special counter 4**

*See chapter 5.1.9 OO Extra*

**OS Special counter 5**

*See chapter 5.1.9 OO Extra*

**OT Special counter 6**

*See chapter 5.1.9 OO Extra*

**OU Free programmable archive**

*See chapter .C.1.5 OU Freely programmable archive*

**OV Dialogs**

*See chapter .C.1.6 OV Dialog*

**OW Texts for Browser**

*See chapter .C.1.7 OW Text for Browser*

**OX RMGView trigger**

*See chapter 5.4.13 OX RMGView Trigger*

**OY DSfG special values DSfG**

*See chapter .C.1.8 OY special values DSfG*

**OZ DSfG archives part 2**

*See chapter .C.1.9 OZ DSfG archive part 2*

---

## **K.16 P Highest load**

**PB Maximum load display, maximum hourly value of the day**

*See chapter 2.5.9 Maximum load*

**PC Maximum load display, maximum hourly value of the month**

*See chapter 2.5.9 Maximum load*

**PD Maximum load display, maximum hourly value of the year**

*See chapter 2.5.9 Maximum load*

**PE Maximum load display, maximum daily value of the month**

*See chapter 2.5.9 Maximum load*

**PF Maximum load display, maximum daily value of the year**

*See chapter 2.5.9 Maximum load*

**PG Maximum load display, maximum minute value of the hour**

*See chapter 2.5.9 Maximum load*

**PH Current maximum load quantities**

*See chapter 2.5.9 Maximum load*



## K.17 Q Archive

### Archive group 1 / counter BM 1

See chapter .C.1.10 Archive groups

### Archive group 2 / fault counter BM 1

See chapter .C.1.10 Archive groups

---

 439
 

---

### Archive group 3 / counter BM 2

See chapter .C.1.10 Archive groups

### Archive group 4 / fault counter BM 2

See chapter .C.1.10 Archive groups

### Archive group 5 / counter BM 3

See chapter .C.1.10 Archive groups

### Archive group 6 / fault counter BM 3

See chapter .C.1.10 Archive groups

### Archive group 7 / counter BM 4

See chapter .C.1.10 Archive groups

### Archive group 8 / fault counter BM 4

See chapter .C.1.10 Archive groups

### Archive group 9 F-instance 1b

See chapter .C.1.10 Archive groups

### Archive group 10 F-instance 2a

See chapter .C.1.10 Archive groups

### Archive group 11 F-instance 2bc

See chapter .C.1.10 Archive groups

### Archive group 12 / Gas quality

See chapter .C.1.10 Archive groups

### Archive group 13 / undefined BM

See chapter .C.1.10 Archive groups

### Archive group 14 / tandem counter comparison via DSfG

See chapter .C.1.10 Archive groups

### Archive group 15 / Freely programmable archive

See chapter .C.1.10 Archive groups

**Archive group 16 / Control counters, extra counters, extra measured values**

See *chapter .C.1.10 Archive groups*

**Archive group 17 Revision part 1**

See *chapter .C.1.10 Archive groups*

440

**Archive group 18 Revision part 2**

See *chapter .C.1.10 Archive groups*

**Archive group 19 Revision part 3**

See *chapter .C.1.10 Archive groups*

**Archive group 20 Revision part 4**

See *chapter .C.1.10 Archive groups*

**Archive group 21 / Log file, alarms, warnings and other messages**

See *chapter .C.1.10 Archive groups*

**Archive group 22 / Highest load values of the day**

See *chapter .C.1.10 Archive groups*

**Archive group 23 / Highest load values of the month**

See *chapter .C.1.10 Archive groups*

**Archive group 24 / Highest load values of the year**

See *chapter .C.1.10 Archive groups*

**K.18 T Trend**

**TA Trend block**

See *chapter 2.5.8 Trend*

**K.19 U IGM****UA Ultrasonic transmitter**

See chapter 5.3.2 UA Ultrasonic volume transmitter

**UB USZ Reynolds correction**

See chapter 5.3.3 UB USZ Reynolds correction

**UC USZ base correction**

See chapter 5.3.4 UC Base correction UC Base correction

**UD USZ Error curve correction**

See chapter 5.3.5 UD Err.curve correction

**UE Effects of Correction**

See chapter 5.3.6 UE Effect

**UF IGM ID display IGM 1**

See chapter 5.3.7 UF ID display IGM 1

**UG IGM ID display IGM 2**

See chapter 5.3.7 UF ID display IGM 1

**UH IGM ID display IGM 3**

See chapter 5.3.7 UF ID display IGM 1

**UI IGM ID display IGM 4**

See chapter 5.3.7 UF ID display IGM 1

**UJ Path 1**

See chapter 5.3.8 UJ Path 1

**UK Path 2**

See chapter 5.3.8 UJ Path 1

**UL Path 3**

See chapter 5.3.8 UJ Path 1

**UM Path 4**

See chapter 5.3.8 UJ Path 1

**UN Path 5**

See chapter 5.3.8 UJ Path 1

**UO Path 6**

See chapter 5.3.8 UJ Path 1

**UP Path 7**

See *chapter 5.3.8 UJ Path 1*

**UQ Path 8**

See *chapter 5.3.8 UJ Path 1*

**K.20 V F instance****VA Current velocity of gas**

See chapter 5.3.9 VA Current velocity of gas

**VB Speed of sound**

See chapter 5.3.10 VB Speed of sound

**VC Ultrasonic profile of velocity**

See chapter 5.3.11 VC Ultrasonic profile

**VD Average values**

See chapter 5.3.12 VD Volume flow

**VE Messages**

See chapter 5.3.13 VE Messages

**VF Signal acceptance**

See chapter 5.3.14 VF Signal acceptance

**VG Signal-to-noise ratio**

See chapter 5.3.15 VG Signal-to-noise ratio

**VH Automatic gain control**

See chapter 5.3.16 VH Automatic gain control

**VI Hourly mean velocity of gas**

See chapter 5.3.17 VI Gas speed hourly mean value

**VJ Register expressions**

See chapter 5.4.7 Protocol type in menu VJ Register plots

**VK Modbus master USM**

See chapter 5.4.9 Configuration VK Modbus according to Instance F

# Egtvkkcvgu

- PTB type approval certificate for calorific value flow computer
- PTB type approval certificate for load registration device
- PTB type approval certificate for effective pressure meter
- PTB type approval certificate for status flow computer

445



Physikalisch-Technische Bundesanstalt  
Nationales Metrologieinstitut

KBS

Konformitätsbewertungsstelle

446



### Baumusterprüfbescheinigung

Type-examination Certificate

<b>Ausgestellt für:</b> <i>Issued to:</i>	RMG MESSTECHNIK GmbH Otto-Hahn-Str. 5 35510 Butzbach
<b>gemäß:</b> <i>In accordance with:</i>	Anlage 4 Modul B der Mess- und Eichverordnung vom 11.12.2014 (BGBl. I S. 2010) <i>Annex 4 Modul B of the Measures and Verification Ordinance dated 11.12.2014 (Federal Law Gazette I, p. 2010)</i>
<b>Geräteart:</b> <i>Type of instrument:</i>	Brennwert-Mengenurwerter <i>Energy conversion device</i>
<b>Typbezeichnung:</b> <i>Type designation:</i>	ERZ2104-NG
<b>Nr. der Bescheinigung:</b> <i>Certificate No.:</i>	DE-16-M-PTB-0026, Revision 2
<b>Gültig bis:</b> <i>Valid until:</i>	28.04.2026
<b>Anzahl der Seiten:</b> <i>Number of pages:</i>	41
<b>Geschäftszeichen:</b> <i>Reference No.:</i>	PTB-1.42-4098367
<b>Nr. der Stelle:</b> <i>Body No.:</i>	0102
<b>Zertifizierung:</b> <i>Certification:</i>	Braunschweig, 05.11.2019
<b>Im Auftrag</b> <i>On behalf of PTB</i>	<b>Siegel</b> <i>Seal</i>

**Bewertung:**  
*Evaluation:*

**Im Auftrag**  
*On behalf of PTB*

Dr. Helmut Többen



Dr. Roland Schmidt

Baumusterprüfbescheinigungen ohne Unterschrift und Siegel haben keine Gültigkeit. Diese Baumusterprüfbescheinigung darf nur unverändert weiterverbreitet werden. Auszüge bedürfen der Genehmigung der Physikalisch-Technischen Bundesanstalt.  
*Type-examination Certificates without signature and seal are not valid. This Type-examination Certificate may not be reproduced other than in full. Extracts may be taken only with the permission of the Physikalisch-Technische Bundesanstalt.*

R3-0012





Physikalisch-Technische Bundesanstalt  
Nationales Metrologieinstitut

KBS

Konformitätsbewertungsstelle



**Baumusterprüfbescheinigung**  
*Type-examination Certificate*

**Ausgestellt für:** RMG MESSTECHNIK GmbH  
*Issued to:* Otto-Hahn-Str. 5  
35510 Butzbach

**gemäß:** Anlage 4 Modul B der Mess- und Eichverordnung vom 11.12.2014  
*In accordance with:* (BGBl. I S. 2010)  
Annex 4 Modul B of the Measures and Verification Ordinance dated 11.12.2014  
(Federal Law Gazette I, p. 2010)

**Geräteart:** Belastungs-Registriergerät  
*Type of instrument:* Load recorder  
und Höchstbelastungs-Anzeigegerät  
and registration device for the maximum load

**Typbezeichnung:** ERZ2000-NG  
*Type designation:*

**Nr. der Bescheinigung:** DE-16-M-PTB-0027, Revision 2  
*Certificate No.:*

**Gültig bis:** 28.04.2026  
*Valid until:*

**Anzahl der Seiten:** 14  
*Number of pages:*

**Geschäftszeichen:** PTB-1.42-4090627  
*Reference No.:*

**Nr. der Stelle:** 0102  
*Body No.:*

**Zertifizierung:** Braunschweig, 30.10.2019  
*Certification:*

**Im Auftrag** Siegel  
*On behalf of PTB* Seal

**Bewertung:**  
*Evaluation:*

**Im Auftrag**  
*On behalf of PTB*

*R. Schmidt*  
Dr. Roland Schmidt



*Helmut Többen*  
Dr. Helmut Többen

Baumusterprüfbescheinigungen ohne Unterschrift und Siegel haben keine Gültigkeit. Diese Baumusterprüfbescheinigung darf nur unverändert weiterverbreitet werden. Auszüge bedürfen der Genehmigung der Physikalisch-Technischen Bundesanstalt.  
*Type-examination Certificates without signature and seal are not valid. This Type-examination Certificate may not be reproduced other than in full. Extracts may be taken only with the permission of the Physikalisch-Technische Bundesanstalt.*

R3-0012

447



Physikalisch-Technische Bundesanstalt  
Nationales Metrologieinstitut

KBS

Konformitätsbewertungsstelle

448



## Baumusterprüfbescheinigung

Type-examination Certificate

<b>Ausgestellt für:</b> <i>Issued to:</i>	RMG MESSTECHNIK GmbH Otto-Hahn-Str. 5 35510 Butzbach
<b>gemäß:</b> <i>In accordance with:</i>	Anlage 4 Modul B der Mess- und Eichverordnung vom 11.12.2014 (BGBl. I S. 2010) <i>Annex 4 Modul B of the Measures and Verification Ordinance dated 11.12.2014 (Federal Law Gazette I, p. 2010)</i>
<b>Geräteart:</b> <i>Type of instrument:</i>	Wirkdruckgaszähler <i>Differential pressure gas meter</i>
<b>Typbezeichnung:</b> <i>Type designation:</i>	ERZ2014-NG, ERZ2114-NG
<b>Nr. der Bescheinigung:</b> <i>Certificate No.:</i>	DE-16-M-PTB-0028, Revision 2
<b>Gültig bis:</b> <i>Valid until:</i>	20.06.2026
<b>Anzahl der Seiten:</b> <i>Number of pages:</i>	43
<b>Geschäftszeichen:</b> <i>Reference No.:</i>	PTB-1.42-4098368
<b>Nr. der Stelle:</b> <i>Body No.:</i>	0102
<b>Zertifizierung:</b> <i>Certification:</i>	Braunschweig, 05.11.2019
<b>Im Auftrag</b> <i>On behalf of PTB</i>	<b>Siegel</b> <i>Seal</i>
	<b>Bewertung:</b> <i>Evaluation:</i>
	<b>Im Auftrag</b> <i>On behalf of PTB</i>

Dr. Helmut Többen



Dr. Roland Schmidt

Baumusterprüfbescheinigungen ohne Unterschrift und Siegel haben keine Gültigkeit. Diese Baumusterprüfbescheinigung darf nur unverändert weiterverbreitet werden. Auszüge bedürfen der Genehmigung der Physikalisch-Technischen Bundesanstalt.  
*Type-examination Certificates without signature and seal are not valid. This Type-examination Certificate may not be reproduced other than in full. Extracts may be taken only with the permission of the Physikalisch-Technische Bundesanstalt.*

R3-0012



Physikalisch-Technische Bundesanstalt  
Nationales Metrologieinstitut

KBS

Konformitätsbewertungsstelle



## EU-Baumusterprüfbescheinigung

*EU Type-examination Certificate*

<b>Ausgestellt für:</b> <i>Issued to:</i>	RMG MESSTECHNIK GmbH Otto-Hahn-Str. 5 35510 Butzbach	
<b>gemäß:</b> <i>In accordance with:</i>	Anhang II Modul B der Richtlinie 2014/32/EU des Europäischen Parlaments und des Rates vom 26. Februar 2014 zur Harmonisierung der Rechtsvorschriften der Mitgliedstaaten über die Bereitstellung von Messgeräten auf dem Markt. <i>Annex II Module B of the Directive 2014/32/EU of the European Parliament and of the Council of 26 February 2014 on the harmonisation of the laws of the Member States relating to the making available on the market of measuring instruments.</i>	
<b>Geräteart:</b> <i>Type of instrument:</i>	Zustands-Mengennumwerter für Gas <i>Volume conversion device for gas</i>	
<b>Typbezeichnung:</b> <i>Type designation:</i>	ERZ20004-NG, ERZ2104-NG	
<b>Nr. der Bescheinigung:</b> <i>Certificate No.:</i>	DE-13-MI002-PTB003, Revision 5	
<b>Gültig bis:</b> <i>Valid until:</i>	28.04.2026	
<b>Anzahl der Seiten:</b> <i>Number of pages:</i>	41	
<b>Geschäftszeichen:</b> <i>Reference No.:</i>	PTB-1.42-4098366	
<b>Notifizierte Stelle:</b> <i>Notified Body:</i>	0102	
<b>Zertifizierung:</b> <i>Certification:</i>	Braunschweig, 30.10.2019	<b>Bewertung:</b> <i>Evaluation:</i>
<b>Im Auftrag</b> <i>On behalf of PTB</i>	<b>Siegel</b> <i>Seal</i>	<b>Im Auftrag</b> <i>On behalf of PTB</i>
 Dr. Helmut Többen		 Dr. Roland Schmidt

R3-072097

## Contact

---

*Subject to technical changes*

### **More information**

If you would like to learn more about the products and solutions from RMG, visit our website:

[www.rmg.com](http://www.rmg.com)

or contact your local sales representative

### **RMG Messtechnik GmbH**

Otto-Hahn-Straße 5

35510 Butzbach, Germany

Phone: +49 (0) 6033 897 – 0

Fax: +49 (0) 6033 897 – 130

Email: [service@rmg.com](mailto:service@rmg.com)

